



# STATE OF THE SEWERS 2012



Michael R. Bloomberg, Mayor  
Carter H. Strickland, Jr., Commissioner



Friends,

As New York City's water and wastewater utility, the Department of Environmental Protection (DEP) serves a vital purpose to the more than eight million New Yorkers: every day, DEP delivers more than one billion gallons of fresh drinking water and treats approximately 1.3 billion gallons of wastewater. To carry out this mission, DEP has an extensive sewer maintenance, repair, and construction program that efficiently and effectively conveys wastewater from homes and businesses through 7,500 miles of sewers to one of 14 wastewater treatment plants.

In *Strategy 2011-2014*, we committed to operating the safest, most-effective, cost-efficient, and transparent water utility in the nation. To accomplish this goal, DEP uses advanced analytical tools and a risk management-based approach to target specific locations that are most problematic. We've dedicated resources to examining not only how to fix a problem now, but also how to proactively target segments, blocks, and even entire neighborhoods to address the underlying conditions that lead to sewer backups. Over the past year, we have begun a number of new initiatives that have had remarkable results:

- Confirmed sewer backups, a term used to describe high levels in the sewers that sometimes result in actual backups in homes and businesses are down 8.5% over last year;
- 99.3% of catch basins are in a state of good repair; and
- 29 million pounds of debris have been removed from interceptor sewers, increasing capacity by more than 100 million gallons annually.

Yet, even with these promising trends, we know that there is more to be done. The analysis in this document not only explains programs already implemented, but also shares information on pilot programs that will drive our field operations for years to come.

I encourage you to read this document in conjunction with the *NYC Green Infrastructure Plan: 2011 Update*, *Strategy 2011-2014: 2011 Progress Report*, *2011 Best Management Practices Report*, and *2011 Harbor Water Quality Report* to get a full understanding of how DEP is working to position the City at the forefront of stormwater management and to create a greener, greater New York.

Sincerely,

A handwritten signature in black ink that reads "Carter H. Strickland, Jr." in a cursive script.

Carter H. Strickland, Jr.  
Commissioner

# TABLE OF CONTENTS

<b>INTRODUCTION</b> .....	5	<b>Extraordinary Storms</b> .....	18
<b>NEW YORK CITY SEWER SYSTEM</b> .....	6	<b>Sewer Repair and Construction</b> .....	19
<b>STREET SWEEPING AND CATCH BASINS</b> .....	7	Safety in the Streets .....	19
Catch Basin Inspection, Cleaning, and Repair.....	8	<b>Staten Island Bluebelt</b> .....	20
<b>SERVICE LINES AND SEWER CONNECTIONS</b> .....	9	High Level Storm Sewers.....	20
Service Line Protection .....	9	<b>INTERCEPTOR SEWERS</b> .....	21
<b>SEWER MAINS</b> .....	10	Interceptor Cleaning .....	21
Fats, Oils, and Grease .....	11	<b>PERFORMANCE METRICS</b> .....	22
Biological Degreasers.....	11	Industry Benchmarks .....	22
<b>Sewer Inspection, Analysis, and Cleaning</b> .....	12	<b>Citywide</b> .....	23
Hydraulic Analysis .....	13	Bronx.....	24
<b>Sewer Operations and Analysis Program Maps</b> .....	14	Brooklyn .....	25
Standard Operating Procedures.....	14	<b>Manhattan</b> .....	26
<b>Tools of the Trade: Sewer Inspection</b> .....	15	Queens.....	27
Sewer Analysis Software .....	15	<b>Staten Island</b> .....	28
<b>Sewer Maintenance</b> .....	16	<b>CONCLUSION</b> .....	29
Training Facility .....	16		
Manhole Sensors .....	17		

# INTRODUCTION

New York City's first sewer was a primitive open canal on Broad Street in lower Manhattan. It was not until the mid-1800s—when public health officials established a link between contact with untreated waste and cholera outbreaks—that the City began plans to construct a citywide sewer system. Before then, it was common for residents to throw the contents of bedpans and washbasins directly out the window and for rotting trash and dead animals to sit on the streets for days.

To prevent future cholera epidemics, the City began to construct underground sewers to carry wastewater from homes and businesses and to drain stormwater from increasingly dense city neighborhoods directly into New York Harbor. Because large swaths of the system were built prior to the consolidation of the five boroughs in 1898, there were no standardized designs or coordinated construction efforts.

The widespread adoption of indoor plumbing around the turn of the century meant that per capita generation of wastewater tracked, and ultimately surpassed, the rate of population growth in the City.

As the amount of wastewater the City generated increased, local waterways became severely oxygen deficient and highly polluted. The resulting odors, closure of commercial shellfish beds, and outbreaks of waterborne diseases led to public support of wastewater treatment plants that would remove many of the harmful pathogens from the wastewater before releasing it into local waterways.

By the early 1900s, the City had constructed its first three wastewater treatment plants that relied on screening and sedimentation to remove solids, and on chlorine to disinfect the wastewater flow. To these steps of “primary” treatment, the City later

added “secondary” treatment in the form of activated sludge or biological units, in which helpful bacteria eat and remove harmful pathogens. To carry wastewater to these new treatment plants, the City built large capacity sewers, called interceptors, to “intercept” direct discharge points and carry wastewater to new facilities for treatment. In low-lying areas, the City built pump stations to lift the wastewater to a higher elevation so it could continue its journey by gravity to the treatment plants.

As the population grew and spread throughout the five boroughs, the City expanded the sewer system to encourage proper drainage and carry wastewater to the treatment plants. To manage the increased wastewater flow from new development, the City upgraded the three original plants and built eleven additional plants by 1987.

Today, an average of 1.3 billion gallons of wastewater per day travel through 7,500 miles of sewers to 14 in-city wastewater treatment plants. To operate and maintain the many components of this extensive system, the New York City Department of Environmental Protection (DEP) has five repair yards, seven sewer maintenance yards, a fleet of specialized vehicles, and a staff of laborers, supervisors, engineers, and analysts. In the last decade, DEP has shifted from a reactive approach to a data-driven, proactive approach to operate and maintain the sewer system. By using a range of digital tools and innovative practices, we can manage risk and provide a high level of service to our customers while focusing investment to maximize the use of limited resources. This report will describe these innovative tools and strategies and demonstrate how the City uses them to operate the sewer system better and more effectively than ever before.

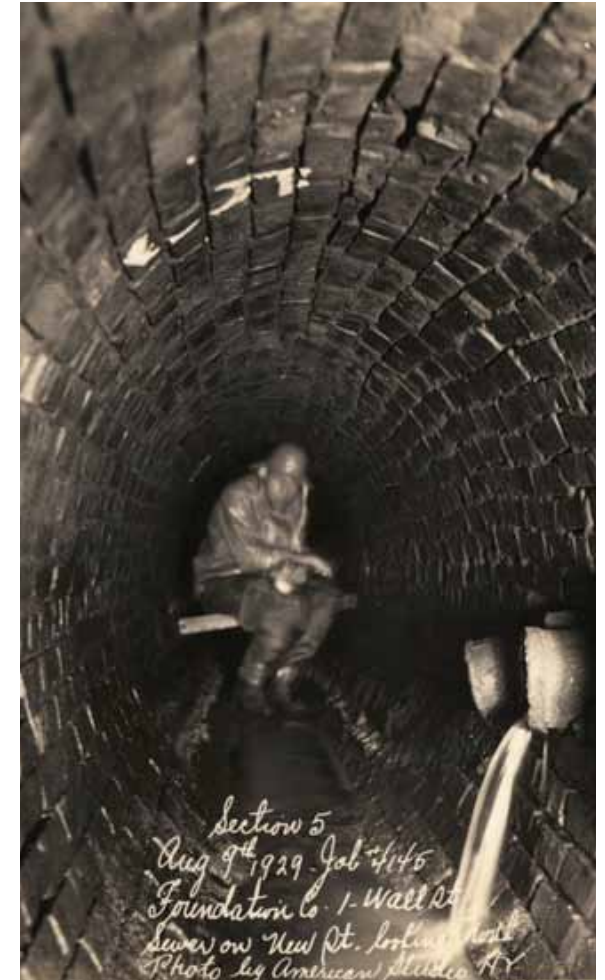

By the early 1900s, sewers were being built across the five boroughs, including the one above, in Manhattan in 1929.

Photo courtesy of the NYC Municipal Archives.

# NEW YORK CITY SEWER SYSTEM

Approximately 60% of New York City's sewer system is combined, meaning that it handles sanitary waste from homes and businesses as well as stormwater from streets and rooftops. This system includes more than 3,330 miles of sewers throughout the five boroughs.

Separate sewers make up the other 40% of the sewer system. In a separate system, sanitary sewers carry wastewater straight to the treatment plant, while storm sewers carry stormwater runoff in a separate pipe directly to a local waterway. The separated sewer system in New York City includes 2,220 miles of sanitary sewers and 1,820 miles of storm sewers. The City also has 138 miles of interceptor sewers which carry both stormwater and wastewater to treatment plants.

Some parts of the city do not have sanitary or combined sewers. Generally, these neighborhoods developed before the sewer system could be extended to reach them, and therefore have suburban-style septic systems that treat wastewater on-site. Recently DEP brought municipal sewers to Meadowmere in Queens, and continues to expand the sanitary and storm sewer network on the South Shore of Staten Island.

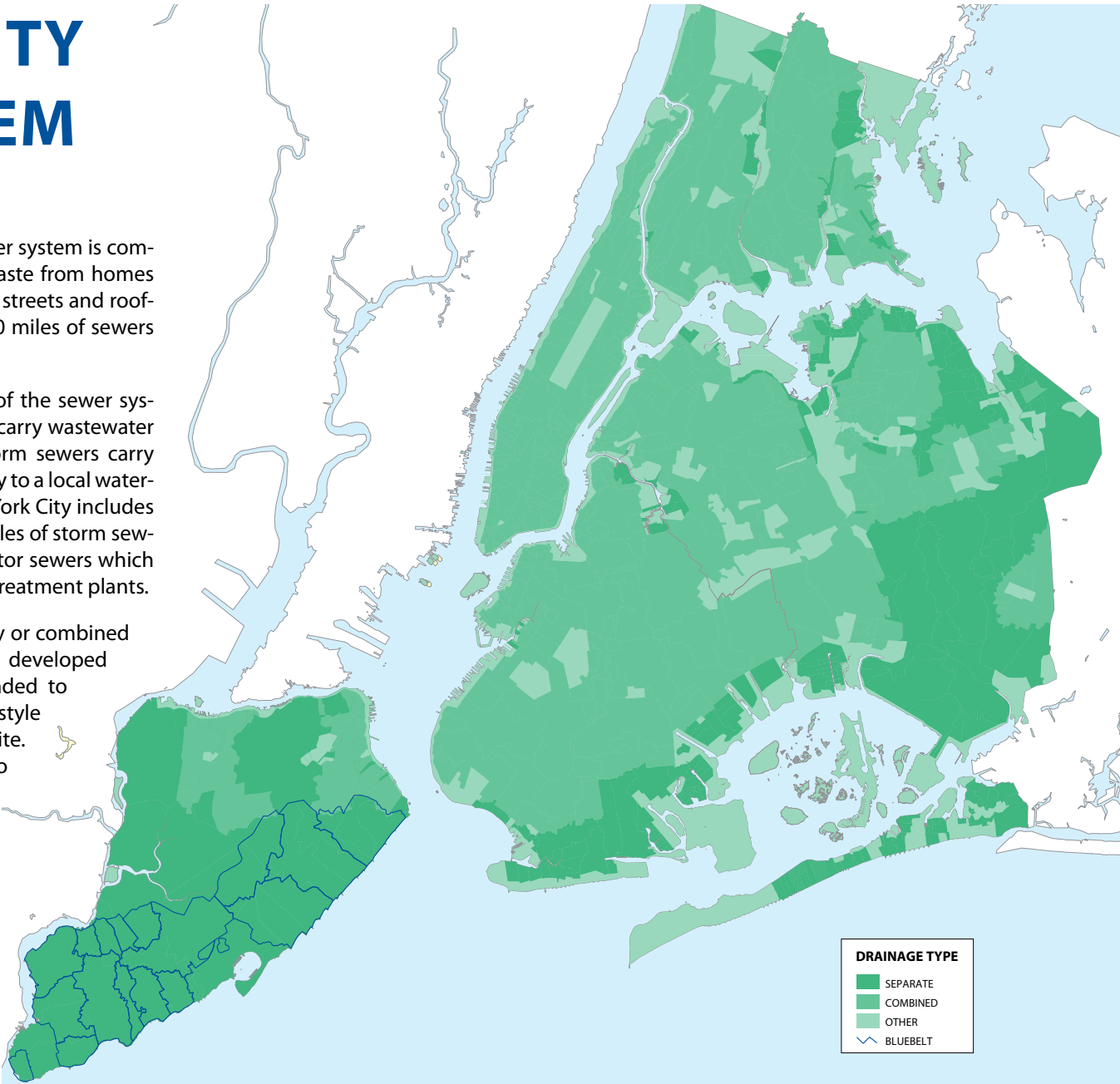

# STREET SWEEPING AND CATCH BASINS

More than a quarter of New York City's land area consists of impervious streets and sidewalks. Most rain that falls on these surfaces ultimately find its way to our sewer system, generating significant amounts of runoff. Just one-inch of rain citywide generates approximately 5.26 billion gallons of stormwater—enough to fill the Empire State Building 19 times.

Since the days of the Romans, roads have been designed with a high point in the center, called a crown, to channel water to the curb line. From there, stormwater flows down the curb, collecting dust, litter, and leaves along its way to the corner, where it falls into one of 148,000 catch basins.

A catch basin is a type of storm drain covered by a heavy metal grate to prevent large objects from falling in, and with a deep sump or storage container to collect dust, dirt, and other debris that runs off the street. A metal hood keeps lightweight objects like soda bottles and plastic bags from flowing into the sewer and helps mitigate unpleasant odors.

Catch basins perform a complex and critical role for the City. Not only do they collect thousands of gallons of stormwater each year, they also must hold the weight of cars parking and driving on their grates and handle the leaves and trash that flow in from the street. DEP cleans tens of thousands of

catch basins a year and repairs basins and grates affected by heavy vehicular traffic.

Excessive litter and debris can mat over the grate, causing water to bypass a catch basin. To prevent this, the Department of Sanitation clears debris from streets before it can cause problems, one of the reasons the City has alternate side parking to allow for street sweeping. When catch basins do not work properly, stormwater can back up onto the street and can cause flooding. New Yorkers can help prevent localized flooding by sweeping debris, including leaves and trash, into trash cans or by calling 311 to report a clogged catch basin.

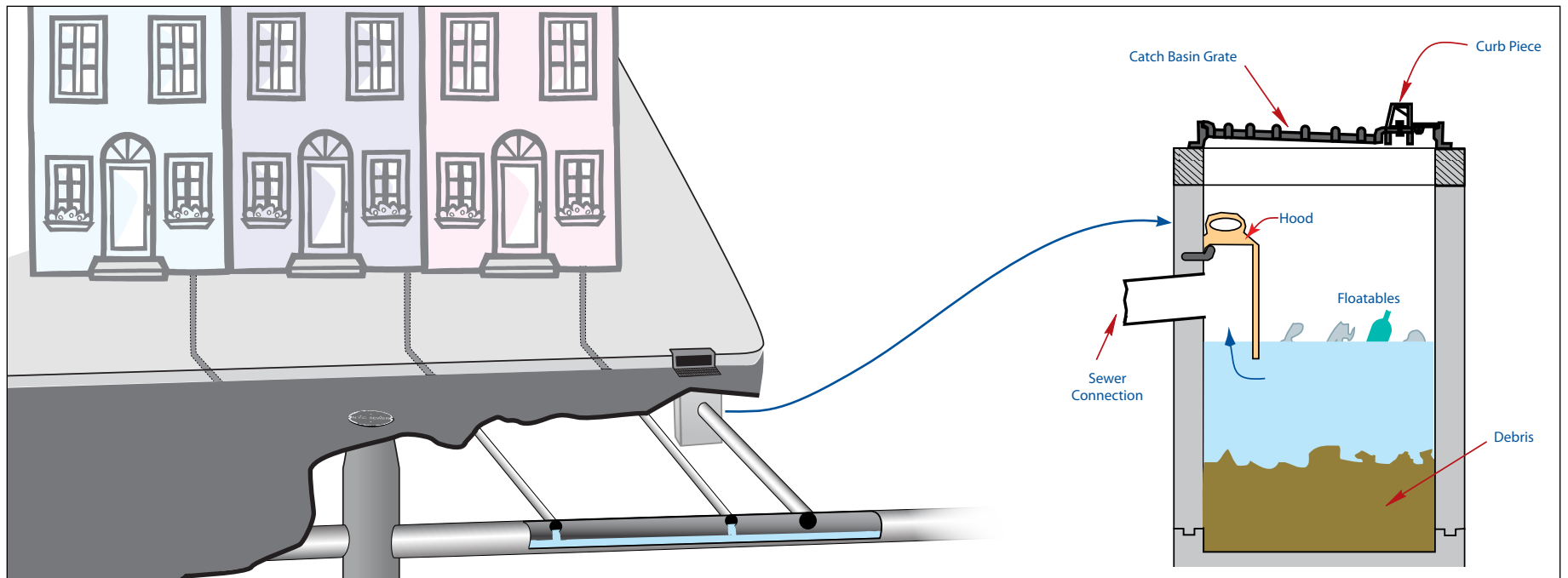

## Catch Basin Inspection, Cleaning, and Repair

DEP keeps a close eye on our catch basins to make sure they perform properly during storms. Our crews inspect all 148,000 catch basins every three years and clean them out as necessary. In the last year, we inspected more than 45,450 basins and cleaned out more than 20,050 of those that needed cleaning. We have also developed a list of the catch basins most prone to flooding, and inspect and clean those when the forecast calls for heavy rains.

DEP also relies on citizens' "eyes on the street." When the City's 311 system receives a report of a clogged or broken catch basin, an operator enters the call into DEP's computerized maintenance management system. This system then assigns the individual order to DEP personnel stationed at field locations around the city. Last year, we cleaned more than 12,860 catch basins in response to customer calls, in addition to the 20,050 cleaned out as a result of our inspection program.

Every time a field crew inspects or cleans a catch basin, they also determine if it requires structural repairs to keep working properly. Those that need work are placed into our computerized maintenance management system, which prioritizes them and notifies our repair yards. In 2010, we began to aggressively target catch basin repairs. In July of that year, we had a backlog of over 2,960 catch basins that needed some repair work. Since then, we have completed 9,150 repairs, cutting the backlog down by almost two-thirds. Today, fewer than 1,000 catch basins have open work orders—only 0.7% of all catch basins citywide.

Although the inspection process regularly generates new work orders, we will continue our focus on catch basin repair to further drive this number lower. In keeping with our standards for other vital

infrastructure, we have evaluated our program and set a new target of fewer than one percent of catch basins with outstanding work orders.

DEP's catch basin inspection and cleaning program has led to a significant decrease in the number of catch basin maintenance and repair complaints received annually. In Fiscal Year 2008, we received more than 18,300 calls about catch basins, and in Fiscal Year 2012, we received 12,370 calls, a decrease of 32%.

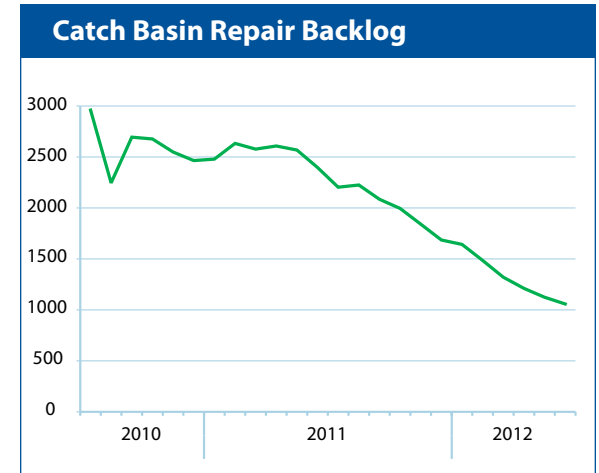

While they look like dump trucks, catch basin machines actually have a specialized boom crane to make catch basin inspection, cleaning, and maintenance much easier. The crane lowers a claw-like bucket that can pick up the protective grate and scoop out debris and sediment that can accumulate in catch basins over time. The built-in box bed carries the debris away from the work site for disposal.

# SERVICE LINES AND SEWER CONNECTIONS

Wastewater from homes, schools, and offices, roof runoff, and other site-generated stormwater join the city's sewer system through a connection beneath the street. Before that point, the water flows through building and service line plumbing that is owned and maintained by the property owner. Traps along the way prevent odors and gases from entering homes, and vertical "stack" pipes direct wastewater down to a building's basement while venting gases up through the roof. Service lines from buildings run under yards and sidewalks to the point of connection with sewers under the roadway. In sewer areas, city codes require that buildings be connected to sewers. As a consequence, almost every building in the city has at least one connection to the sewer system.

Sewer connections are a critical component of infrastructure on which residents and businesses rely. It is important that each one is designed and installed to allow appropriate flow and to endure freezing

temperatures, tree roots, and other elements of nature. DEP and the Department of Buildings review plans and applications for new connections to a sewer line. All sewer connections must follow DEP rules and regulations, and must be overseen by a licensed engineer, subject to DEP's approval. Improper installation can lead to gaps and cracks in the sewer that can allow stormwater to infiltrate and cause sewers to collapse.

When DEP responds to 311 calls of street flooding, cave-ins, or sewer backups, our crews determine whether the condition is due to the failure of a city sewer, failure of a service line, or an overtaxed condition due to a rain event. If the crew determines that the condition is due to the failure of a city sewer or an overtaxed condition due to a rain event, the appropriate resources are deployed to investigate and resolve the issue. If the condition is due to the failure of a service line, the property-owner is responsible for repairs to fix the break.

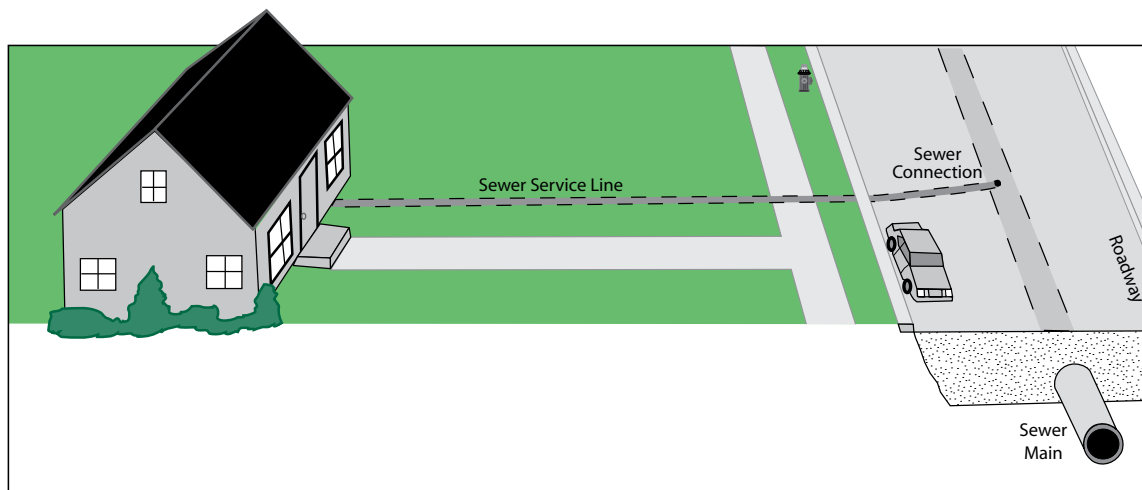

## Service Line Protection

Property owners in New York City are responsible for maintaining their water and sewer service lines, which run from inside the property to the city-owned water or sewer main in the street. If DEP determines that a leak is on a private service line, we issue a notice to the property owner directing that the repair be made in order to protect the roadway and other utilities.

Repairing or replacing broken or leaking service lines costs \$4,000 on average. In 2013, DEP will launch a Service Line Protection Plan, similar to a basic insurance policy, which would spare homeowners the costs of unexpected service line repairs and minimize overall disruption to the local community.

The service line protection plan will be available to customers who pay a small monthly premium in exchange for guaranteed repair of a service line break. It will significantly benefit New York City's water customers by insulating them from high repair costs and providing them with a contractor they can call for timely, high-quality repair if a line breaks. Additionally, the speedy repair of leaking service lines will help reduce damage to owners' property and city infrastructure and minimize the disruption and expense to customers and DEP when water service is shut down because leaks have not been repaired in a timely manner.



# SEWER MAINS

New York City has more than 7,500 miles of sewers that range in size from 6 inches to more than 30 feet—the largest are massive storm sewers that carry stormwater from roof drains, streets, sidewalks, driveways, and catch basins out to the waterways of New York Harbor. In some parts of the city, multiple storm sewers are built side-by-side for increased capacity. The oldest sewers date to the 1820s, and are typically constructed of brick, clay, or cement; newer lines are built of reinforced concrete or vitrified clay, a very hard material that resists corrosion from chemicals commonly found in wastewater. Sewers are constructed in a variety of shapes, including rectangular, circular, and elliptical.



Regardless of their shape and size, all sewers are designed to convey wastewater fast enough to prevent debris and sediment from settling and creating blockages, but slow enough to prevent scouring and erosion. Even though sewers are designed to clean themselves, obstructions do appear. One cause is fats, oils, and grease that are disposed of in the drain rather than in the garbage. When this happens, the grease cools into a hard, cement-like substance that lines the edges of the sewer, decreasing both the capacity of the sewer and the flow of the wastewater.

According to the Environmental Protection Agency, grease accounts for nearly half of all backups in sewers nation-wide. New York City data are consistent with those findings. An analysis of confirmed sewer backups (see page 12) showed that grease was the primary cause of sewer backups compared to other potential causes, accounting for more than half of all blockages found. Other problems can also affect the ability of sewers to function as designed. For instance, the roots of trees that are above and near sewers can break through sewer joints, and some older sewers can undergo erosion over time that can create cracks and even cause collapses.

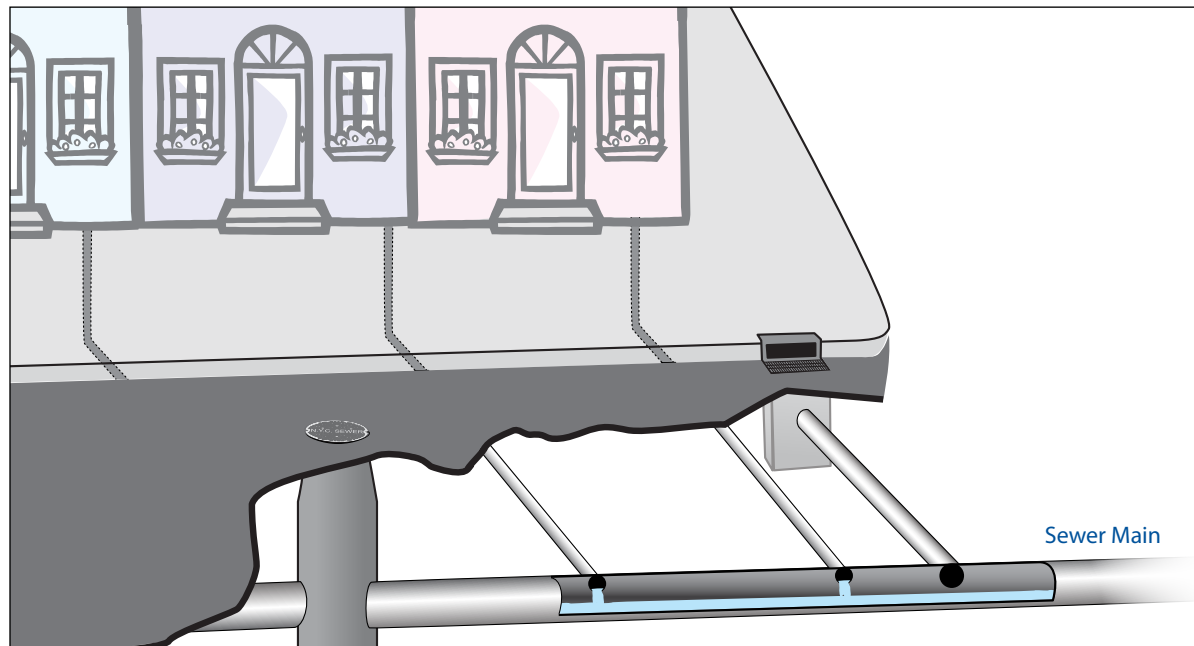

Wastewater from service lines and stormwater from catch basins flow into sewer mains that run under the streets. These narrow branches connect to larger and larger sewers, which eventually converge deep underground into trunk sewers that serve entire neighborhoods. From trunk sewers, wastewater continues to flow by gravity to interceptor sewers, and from there to wastewater treatment plants.

## Fats, Oils, and Grease

DEP has a number of programs to fight the buildup of grease in city sewers. Restaurants, hospitals, schools, and other businesses that serve food are required to install traps to contain grease at the source. DEP regularly inspects these traps to make sure that they are properly sized, installed, and cleaned. In Fiscal Year 2012, our inspectors visited 3,100 establishments, and issued violations to 400 of those for failing to clean and maintain their traps. In addition, inspectors from the Department of Health and Mental Hygiene check for proper grease trap sizing during regular restaurant inspection.

Since July 2010, DEP community outreach representatives have visited nearly 700 restaurants located in neighborhoods with a history of grease buildup to distribute information and answer questions about grease buildup and proper disposal. DEP has sent educational information to many professional

organizations and published nine grease education articles in plumbing, construction, and building management trade newsletters. DEP also provides education for industry professionals directly and has hosted three continuing education courses for Licensed Master Plumbers in the last two years. Today, much of the grease that restaurants use can be recycled into fuel or fertilizer, and licensed grease hauling companies will often collect used grease for little or no fee.

In 2010, the City passed a local law requiring that heating fuel contain 2% biodiesel by October 2012, an initiative that will continue to broaden the market for recycling used cooking grease and oil. DEP has a partnership with the Business Integrity Commission to inform business owners of their responsibility to properly handle waste grease and to jointly inspect local restaurants.

DEP also reaches out to home cooks to teach them how to properly dispose of cooking grease. Community outreach representatives meet with property managers and co-op boards to relay the importance of grease management. Our community outreach staff has distributed more than 60,000 "Cease the Grease" flyers to residents across the city. We continue to seek innovative approaches to reducing grease from home cooking, and we are piloting projects in large developments to collect and recycle grease rather than send it to landfills.

Through an in-depth inspection and analysis program, DEP identifies areas that need programmatic degreasing on a monthly, quarterly, or annual basis. Field crews flush the segments with a combination of water and chemical degreaser, which breaks down the grease molecules and prevents them from re-solidifying.

## Biological Degreasers

To help address the problem of recurring grease buildup, DEP evaluated a number of new degreasing products to determine what would be most cost-effective, efficient, and environmentally sustainable. By the end of 2012, DEP will pilot a new technology that will add natural and beneficial microorganisms into the wastewater stream to digest fats, oils, and grease before they build up on the perimeter of the sewers. DEP is working with the manufacturer to install this technology at a location that experiences persistent grease issues and plans to install the pilot units by 2013.



A clean sewer, without grease or oil build up, allows appropriate flow downstream.

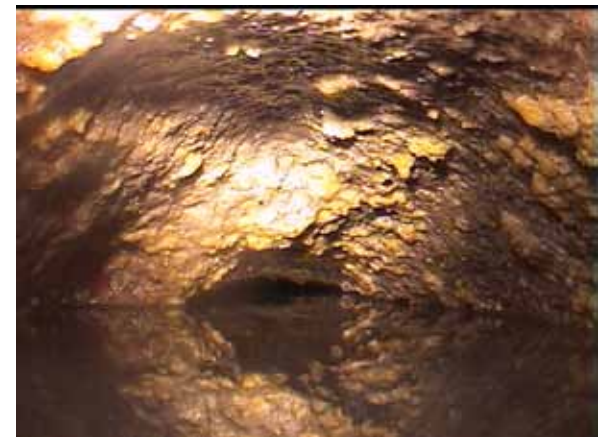

A dirty sewer, with significant grease and oil build up, hinders wastewater flow.

## Sewer Inspection, Analysis, and Cleaning

In the last decade, DEP has implemented technologies and procedures to shift from reactive to proactive sewer maintenance. In 2011, DEP created the Capacity, Management, Operations, and Maintenance section to employ the most up-to-date strategies in areas that would benefit most from proactive interventions like increased cleaning.

To support this section, DEP has: enhanced our Geographic Information System (GIS) containing digital, searchable maps of all of our sewer lines, manholes, and other infrastructure; developed procedures and guidelines to institutionalize pre-existing field practices and trained our field crews to follow these guidelines; and expanded tracking data on customer service requests related to sewer back-ups, including cause, location, and frequency, to facilitate identification of trends and provide better service.

DEP also has a Sewer Operations and Analysis Program, which investigates areas that have a high frequency and density of confirmed issues. Analysts then map reported sewer backups to better visualize and identify segments and neighborhoods that have recurring problems. After the Sewer Operations and Analysis Program defines a study area, DEP closely inspects sewer segments to identify underlying factors and primary causes of recurring confirmed sewer backups. Once DEP identifies the cause, we develop a remediation plan, which can include degreasing, regular cleaning, repair, and/or replacement.

In October 2011, DEP implemented a field checklist for crews responding to sewer backup complaints to better understand the causes of backups citywide. After visually inspecting the impacted sewer segments, crews identify and record the potential cause of the confirmed backup. In the first ten months of



Mechanical rodders are used to clean accumulated grease and debris out of sewers. Rodders use a fast-moving rod to dislodge the debris from the sewer walls. The rod is at the end of a long, flexible hose that allows the machine to reach far into the line.

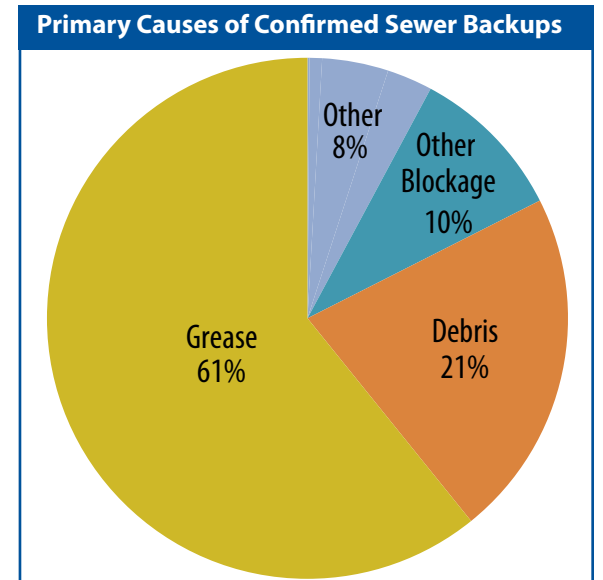
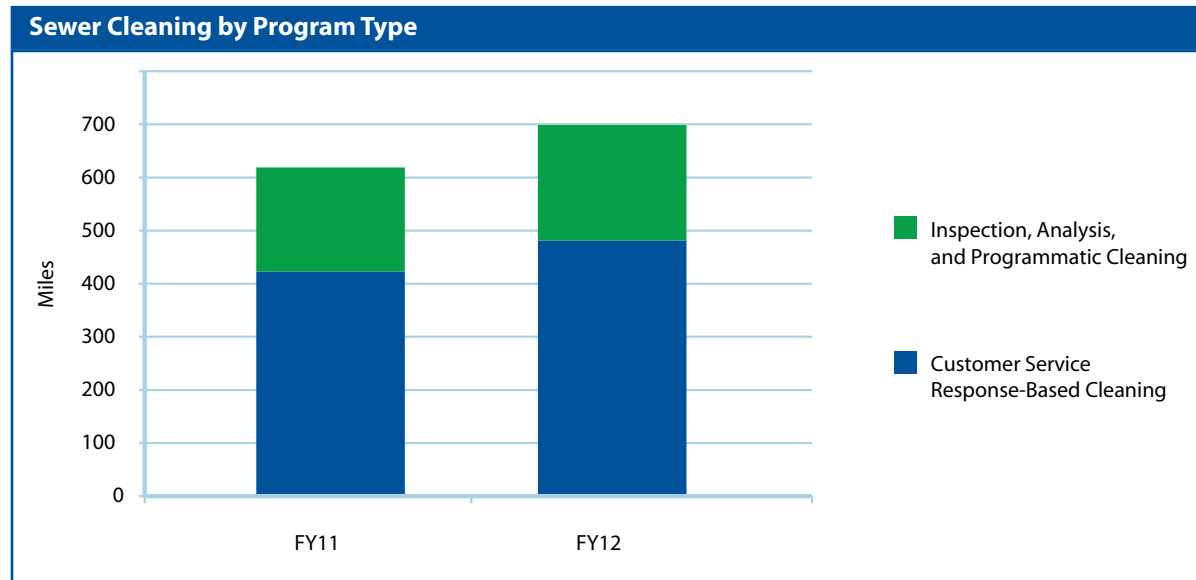

the program, DEP determined that 61% of confirmed sewer backups citywide were primarily caused by grease buildup. Debris was the primary cause of 21% of backups, and other blockages were the primary cause of 10% of backups. Sewer collapse, overtaxing due to rain, and undetermined problems were responsible for less than 8% of backups citywide.

Most of the cleaning performed through the Sewer Operations and Analysis Program is done by DEP sewer maintenance crews using specialized trucks.

The rest of the cleaning is assigned to contractors that specialize in larger and deeper sewer segments. In Fiscal Year 2012, DEP inspection and analysis programs together cleaned more than 218 miles of sewers. These programs are in addition to DEP's regular sewer maintenance program. In most cases, field crews clean and flush sewer segments when responding to backup calls, cleaning 481 miles of sewers in Fiscal Year 2012. Altogether, the City cleaned 699 miles of sewers in Fiscal Year 2012.

## Hydraulic Analysis

DEP uses hydraulic modeling software to inform sewer design and analysis. This software uses a variety of data—including population density, topography and land use data, rainfall data, and the characteristics of the existing sewer system—to model sanitary and stormwater flows in the sewer system. DEP uses this model to analyze system capacity and performance during various storm events, and the model allows engineers to easily evaluate multiple alternative designs for capital construction projects.

Hydraulic analysis also provides engineers with a system-wide approach to design and analysis, because they can assess the upstream and downstream effects that a project will have within the existing sewer network and in relation to other proposed capital projects.

Additionally, hydraulic models can use data collected from in-system monitoring, like sensors mounted to manhole covers (see page 17) to verify assumptions made in the model, increasing our confidence in the conclusions drawn from the model and informing future decisions based on actual data.



Flushing trucks have large, diesel-powered pumps that force jets of pressurized water into a clogged sewer line, flushing out debris and obstructions. In most cases, when a field crew responds to a sewer backup call, they use these machines to flush the sewer and ensure the line is clean and working properly.

## Sewer Operations and Analysis Program Maps

DEP's Sewer Operations and Analysis Program combines sewer data with a geographic distribution of sewer backups to investigate areas that have a high frequency and density of confirmed sewer backups. Analysts then map these data to better visualize and identify segments and neighborhoods that have recurring problems.

Each borough is divided into small working units, called grids. From there, analysts determine which specific grids have the highest concentration of confirmed sewer backups, and color-code them based on frequency and type of sewer system. For example, grids within the combined system with

one confirmed sewer backup in any fiscal year are shaded yellow, grids with two or three confirmed sewer backups are shaded orange, and grids with four or more confirmed sewer backups are shaded red. Similarly, varying shades of green indicate the frequency of confirmed sewer backups in areas served by separate sewers.

These operational tools help analysts see clusters of confirmed sewer backups, so DEP can more effectively target cleaning and maintenance activities. Analysts can also compare maps over time to see which areas have shown improvement or need targeted maintenance.

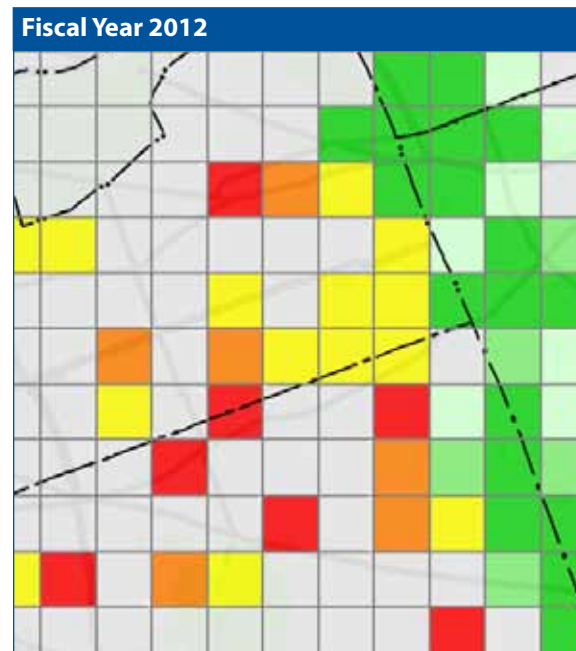
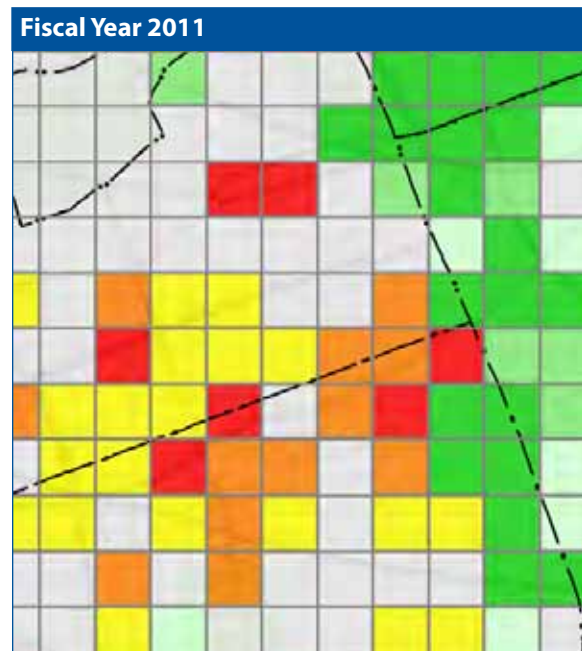

Sewer Operations and Analysis Program maps, like the one shown above, are operational tools that help analysts understand the extent of problematic areas.

## Standard Operating Procedures

In 2011, DEP developed fourteen standard operating procedures that detail the roles, responsibilities, policies, and actions related to a range of sewer maintenance responses. These include the investigation of sewer backup complaints, programmatic catch basin cleaning, and sewer inspection by closed circuit television, among others.

Standard operating procedures give step-by-step instructions for DEP field crews and staff to follow when they are responding to customer complaints, performing scheduled maintenance, and analyzing sewer backup data. In addition to ensuring consistency and reliability across our operations, these standard operating procedures have contributed to better reporting and resource allocation since they have been put in place. All field operations crews have been trained on, and are using, these new standard operating procedures.

## Tools of the Trade: Sewer Inspection

One of the most effective ways DEP crews are able to evaluate sewer conditions is through inspection. Historically, the only ways to inspect the inside of sewers were visually and with still cameras. Visual inspections, when crews climb inside manholes and pipes to spot potential issues, involve a number of necessary safety steps and other challenges that reduce the number that DEP can perform. Still cameras placed on floats and set to take photographs at regular intervals remove the need for crews to wade through wastewater, but they do not capture the level of detail that is needed for in-depth analysis. Today, we use a number of new and existing tools in combination to enhance our visual inspection process. In Fiscal Year 2012, the Capacity, Management,

Operations, and Maintenance Section performed 854 targeted inspections of sewers with recurring backups and cleaned 41 miles of sewers.

Just as online mapping services use car-mounted cameras to facilitate navigation of new areas, DEP staff can “walk” through many of our sewer lines using data from closed circuit television (CCTV) sewer inspections. Through the CCTV inspection process, DEP has collected more than 8,700 hours of footage by lowering a camera mounted to a floatation device down a manhole. The CCTV machine floats through the sewer taking images along the way. DEP then downloads these data from the device to evaluate and catalogue the information.

Unlike CCTV, which documents the condition of the sewers above the level of the water line, SONAR technology provides DEP with a scan of the sewer condition both above and below the water line. Just like CCTVs, DEP floats SONAR devices down the sewers where they use sound waves to document the level of sedimentation beneath the water’s surface.

Although CCTV and SONAR devices provide a wealth of data about a particular sewer segment, they are not always the fastest or most cost-effective ways to explore the sewers. This year we have piloted the use of a new type of pole-mounted camera for sewer inspections. These sophisticated cameras are mounted on poles and equipped with strong zoom lenses and powerful lighting to increase visibility in the otherwise dark sewers. Field crews can lower the pole camera down a manhole and zoom as needed to conduct inspections. Zoom capabilities allow crews to see sewer details up to 100 feet away from the manhole, including common problems such as tree roots, bad joints, cracks, and collapsed pipes.

### Sewer Analysis Software

In order to effectively manage this extensive collection of inspection footage, DEP has evaluated a number of popular CCTV cataloging systems to integrate our recordings with GIS maps. This software will combine information housed in GIS, such as the age, materials, and dimensions of the sewer, with actual video footage of the sewer. DEP conducted a three month trial period, during which we worked with a software developer to customize the system to meet our needs. Once DEP selects and implements a software package, field crews and office staff will be able to quickly and easily access CCTV recordings of any sewer segment that we have surveyed, giving them up-to-date information about the condition of the sewer from its last inspection.



In both the above and below images, the top half shows a CCTV camera view of the sewer and the bottom shows the corresponding SONAR view below the water’s surface. Together these two technologies provide DEP with a comprehensive view of the sewer.



## Sewer Maintenance

To maintain the vast sewer network, DEP dispatches sewer maintenance crews from seven yards spread out over the five boroughs. These yards are equipped with specialized vehicles designed to help crews effectively inspect and clean parts of the sewer system.

Even with our focus on technology and proactive maintenance methods, complaint-based reactive cleaning and repairs are still an important component of our sewer maintenance program. In Fiscal Year 2012, DEP received approximately 39,000 sewer-related customer service requests submitted via the City's 311 system. Requests are handled at the call center by 311 operators, who enter service requests into our computerized maintenance management system. Not every call corresponds to an actual problem with the sewer system, but our field crews respond to each call and determine an appropriate course of action.

When our field crews respond to a customer call about a potential sewer backup, they first open manholes around the area where the backup or blockage is reported. Sewer segments with full or partial blockages will typically have higher than expected wastewater levels in the upstream manhole. This is noted as a "confirmed sewer backup" whether or not any backups occur. If the sewer is running at a higher level than normal, crews perform a visual inspection of the manhole and segment, looking for possible causes and recording their findings. After that, they either flush the segment themselves or request more specialized equipment to perform the cleaning. In most cases, crews proactively flush or clean the sewer segment with water to ensure that it is clean and working properly. In Fiscal Year 2012, DEP crews cleaned 481 miles of sewers when responding to customer calls.



## Training Facility

Field crews are the key to a successful sewer maintenance program, and DEP continues to innovate the way we train our workforce. In May 2012, DEP opened a brand new training facility with a full-scale model street complete with all the features of a real city street: mock sewers, catch basins, and hydrants. New maintenance and repair staff begin their DEP careers at the center, receiving operational and safety training on equipment used by our crews covering all four phases of the apprenticeship program: water repair, sewer repair, sewer maintenance, and water maintenance. For example, apprentices learn how to repair and replace fire hydrants; safely operate truck hoists, compressors, jackhammers, and pipe saws; and receive hands-on training on forklift use and proper on-site preparations for emergency work zones. This facility will also be used for continuing education of our experienced workforce as we roll out successful training programs to all our crews.

At the training facility, crews receive environmental, health and safety training to ensure that they are carrying out their responsibilities safely and in compliance with the many local, state and federal regulations that establish standards for water quality, clean air, worker safety, and other aspects of our work. DEP's goal is to run the safest operations and capital program in the country. That is why DEP administers a consistent, efficient, and comprehensive Environmental, Health and Safety program throughout the agency.



## Manhole Sensors

Manholes offer DEP the crucial ability to inspect the sewer from street level and access it when repairs are needed. Field crews typically perform visual assessments by removing one of the city's 429,000 manhole covers and looking down into the sewer below. DEP is piloting sensors attached to the bottoms of manhole covers to measure the elevation of wastewater in the sewer and to wirelessly transmit that information to our computer system. If the elevation approaches a level that could result in a surcharge or sewer backup, the sensor sends an alarm that allows DEP to dispatch crews to check and, if needed, fix the problem before it results in a sewer backup. As a result of the pilot's early success, DEP installed 20 additional sensors in 2012, and will install another 20 in the first half of 2013.

The combination of the City's robust 311 system and DEP's rigorous sewer inspection, analysis, and cleaning program has produced tangible improvements to the level of sewer service. From Fiscal Year 2011 to 2012, sewer backup complaints decreased by 3.7%, and "confirmed" sewer backups, those verified by visual inspection, decreased by 8.5%. In Fiscal Year 2012, only 1.8% of the nearly 158,000 street segments, the length of sewer as long as a city block, experienced a backup. Meanwhile, the average resolution time for sewer backups stayed level at 5.6 hours, even with the challenge of record-breaking storms like Hurricane Irene.

Through efforts like the Sewer Operations and Analysis Program, DEP has seen even more improvement in the number of street segments with recurring sewer backups—multiple backups on the same segment in the same year. By using more advanced inspection technology and analysis techniques, we have identified areas where problems are most likely to occur and have greatly reduced recurring issues. In Fiscal Year 2012, the number of sewer segments with recurring backups decreased by 9.5% compared to the previous year, and the number with recurring backups in dry weather decreased by 18.0%. In Fiscal Year 2012, less than 0.4% of 158,000 sewer segments experienced recurring backups in dry weather.

### Sewer Backup Complaints

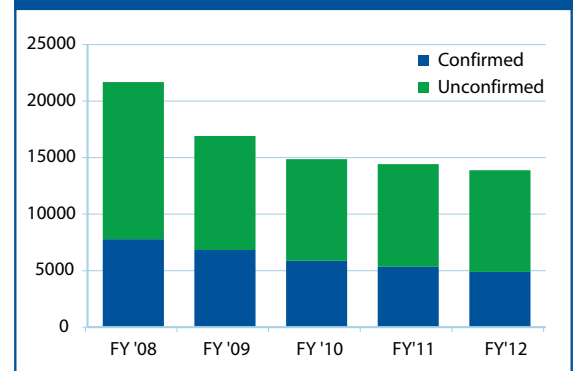

### Segments with Recurring SBUs

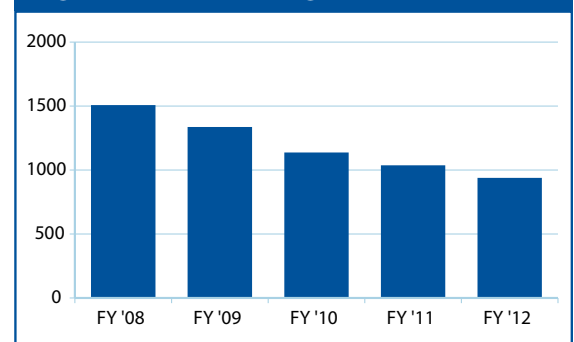

### Segments with Recurring Dry Weather SBUs

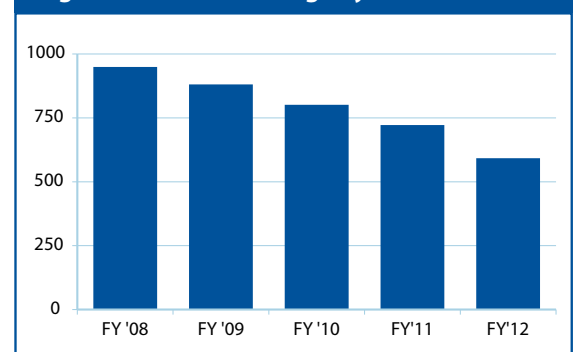



# Extraordinary Storms

Catch basins and sewers are designed to handle most of the storms that pass through New York City. Much of the city sewer system was designed to handle up to 1.5 inches of rain per hour. In the 1960s, DEP increased this design capacity to the current standard of 1.75 inches of rain per hour, the standard we use when developing and revising drainage plans today. As climate change trends become more certain, DEP will continue to explore innovative strategies to improve system performance and increase the capacity of the system.

Some storms, especially hurricanes and nor'easters, unleash rain at rates and in quantities that exceed the system's designed capacity, causing street

flooding, system overtaxing, and sometimes sewer backups. During those events the city receives more customer service complaints than is typical.

For example, in August 2011, New York City experienced two such events, receiving more than 17 inches of rain over the course of the month; Hurricane Irene alone dumped almost 6 inches of rain on the city, with a maximum intensity of more than 1.5 inches per hour. The combination of rainfall, a 4.4 foot storm surge, and other factors led to more than 1,100 sewer backup calls. The vast majority of these calls related to sewers and catch basins that were simply overtaxed by the intensity of rainfall, which was far in excess of design capacity.

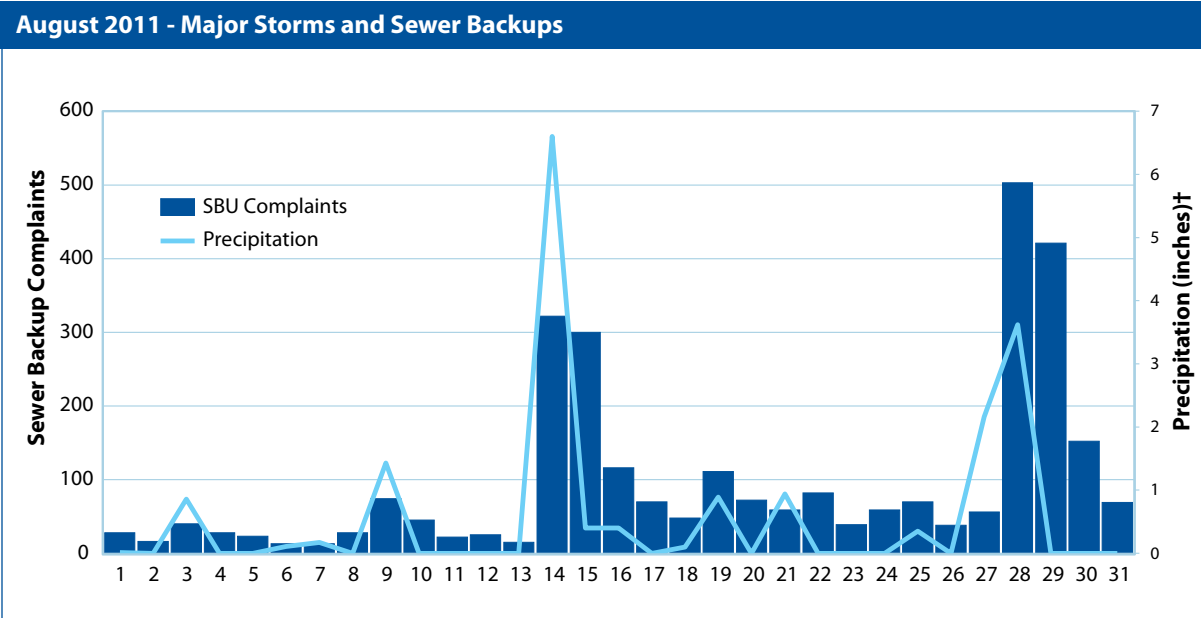

Significant storms during the month of August 2011 led to higher than average sewer backup complaints. On August 14th, 6.6 inches of rain, the highest amount on record for a single day, fell in New York City. Two weeks later, Hurricane Irene dropped 5.8 inches of rain from August 28th to August 29th.



## Sewer Repair and Construction

Repair crews based at DEP’s borough repair yards, are responsible for fixing catch basins, manholes, and sewer lines that make up the sewer system, as well as for repairing the tunnels, shafts, and mains that make up the in-city water distribution system. Field crews respond to customer service requests for broken catch basins and cracked and missing manhole covers as well as issues identified in sewer inspection.

DEP also has on-call contractors to speed up emergency repair of sewer segments. To repair sewers less than four feet wide that have minor cracks, crews line existing sewers with a super-strong, thin plastic layer. To repair cracks in sewers larger than

four feet, crews can line the interior of an existing sewer with an additional three inches of concrete, sealing up any holes, and strengthening the structure of the sewer at a lower cost than replacement. Since 2002, DEP has repaired 67 miles of sewers at a cost of nearly \$60 million.

The City invests extensively in capital sewer construction and replacement. These projects are initiated for many reasons, including improving deteriorated or failing systems, enhancing system capacity to new demands from development, and expanding sewer lines into previously unsewered areas. The City plans and builds sewer segments as part of a 10-year capital program. In some areas—like southeast Queens

and southern Staten Island—DEP has worked to re-develop large-scale drainage plans, replace existing sewers, and construct new ones. Since 2002, the City has invested more than \$1.5 billion to construct or replace 400 miles of sewers.

## Safety in the Streets

Central to DEP’s core mission is our goal to be the safest water utility in the nation. DEP employees who are tasked with maintaining and repairing water and sewer infrastructure not only take pride in their work, but are also experienced, knowledgeable, and well trained in how to carry out their work in the safest possible way. DEP’s field crews receive specialized training in traffic work zone safety, confined space entry, excavation safety, and equipment safety. All work tasks—everything from operating a Vactor truck to using a hand shovel—are periodically evaluated by environmental, health and safety field staff to identify potential work hazards. From these evaluations, controls and safe work protocols are developed and implemented. Additionally, field employees are trained on the safe operation of field equipment at the Training Facility (see page 16), where safety is a key component of the curriculum. DEP recognizes and supports employees and work crews who go above and beyond in safety through the annual safety awards and the employee of the month program.

Sewer Construction and Repair

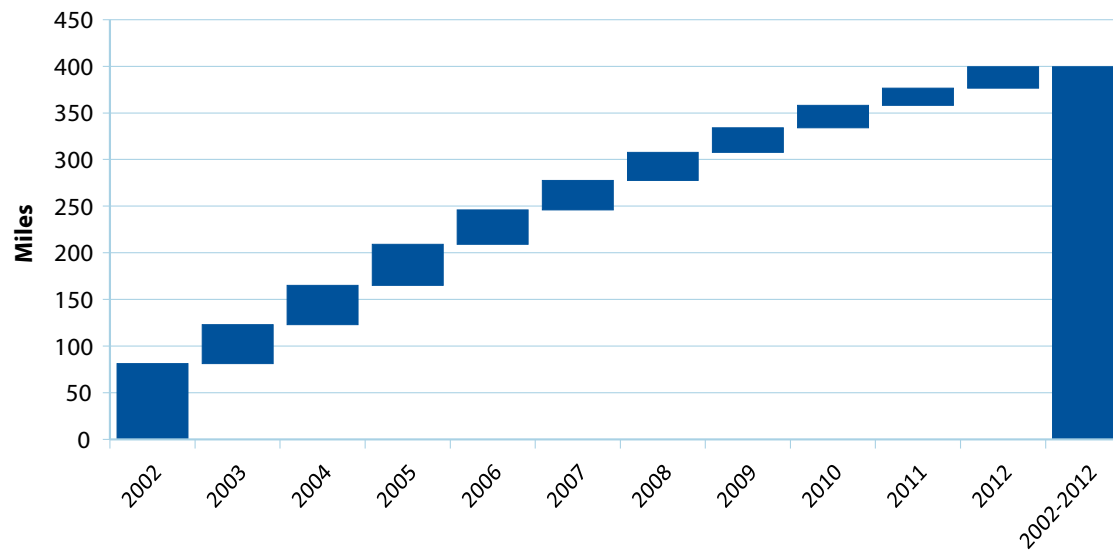

## Staten Island Bluebelt

Since the 1990s, DEP has developed the Staten Island Bluebelt, an innovative stormwater management system to provide drainage for approximately one-third of Staten Island's land area. The Bluebelt consists of man-made and natural streams, ponds, and wetlands that detain, convey, and treat stormwater. Due to the topography of many Staten Island neighborhoods, a conventional storm sewer system would have been incredibly costly and would have eliminated many of the island's remaining natural streams and wetlands. In addition to the construction and improvement of wetland sites, the Bluebelt program also includes investments in storm and sanitary sewers in surrounding neighborhoods, bringing comprehensive wastewater collection to previously underserved areas.

In addition to managing stormwater in Staten Island neighborhoods, the Bluebelt also provides enhanced habitat for a variety of native animal and plant life. The wetlands are designed to accommodate wildlife, incorporating fish ladders, habitat niches, and a variety of trees, plants, and shrubs into the design. The sites are often visited by local birding and naturalist groups, and they have become an integral part of the Staten Island Greenbelt park system. The City has invested more than \$340 million to construct more than 60 Bluebelt sites in Staten Island. DEP has recently expanded the program to sites in Queens and the Bronx, and plans to build additional Bluebelts in the Mid-Island region of Staten Island. DEP currently has 55 Bluebelts in planning, 26 in design, and seven in construction.



## High Level Storm Sewers

High Level Storm Sewers are one strategy for alleviating pressure on the combined sewer system during wet weather and for limiting combined sewer overflow events by channeling runoff from streets and sidewalks into a separate sewer. Where these are built, DEP expects this partial separation of the sewer system to divert 50% of the stormwater runoff from the combined sewer system, preserving capacity in combined sewers and reducing the volume of stormwater sent to wastewater treatment plants or discharged as combined sewer overflow. In addition, High Level Storm Sewers can help to alleviate street flooding. However, because this strategy requires a separate pipe and outlet to a waterbody, it is most cost-effective in areas that are near the water's edge. DEP began construction on high level storm sewers in the Bronx this year, and will break ground on additional projects in Southeast Queens and Gowanus in Fiscal Year 2013.



New Creek Bluebelt in Staten Island

# INTERCEPTOR SEWERS

After passing through a series of progressively larger main and trunk sewers, the wastewater flows through a regulator, which controls wastewater flow, and into a large pipe deep underground. These massive sewers, called interceptors, are the super-highways that carry a combination of sanitary wastewater and stormwater from the combined sewer mains and sanitary mains directly to the wastewater treatment plants. Across the system, they vary in size (from 30" to 192" wide) and shape (from rectangular to horseshoe shaped). The 138 miles of interceptor sewers in New York City carry nearly 4 billion gallons of wastewater per day when it rains.

Although the wastewater treatment system can treat and disinfect twice the dry weather flow, heavy storms can exceed the system's capacity. This causes wastewater to discharge, called combined sewer overflow, into New York Harbor in order to prevent treatment plants from becoming compromised. Interceptor sewers also temporarily store significant quantities of wastewater during wet weather. This increases the overall storage capacity of the system, allowing the stored wastewater to flow to a plant after the rainfall ends and reducing the volume of combined sewer overflow.

## Interceptor Cleaning

The wastewater flowing in the interceptor sewers typically moves fast enough to prevent sediment from settling to the bottom of the pipe. However, bulk trash and debris—including yard or construction debris that is illegally disposed of in the sewer

system—can create dams that slow the flow and allow sediment to settle.

DEP uses Vactor trucks to clean interceptor sewers. Vactor trucks have a powerful vacuum system that can suck debris, grease, and sediment that has accumulated in sewers. Each Vactor truck has a 30 foot vacuum hose and a water jet to clear clogs for the vacuum to pick up. When the Vactor trucks are full, the sediment and debris are removed from the truck and placed in containers for transport to a landfill.

Over the last two years, DEP surveyed all 138 miles of interceptor sewers using a floating sonar device, which uses sound waves to document the level of sedimentation beneath the water's surface (see page 15). As a result of this survey, which found that 19% of the system needed cleaning, sewage treatment workers cleaned 138,000 linear feet of pipe, or 26 miles, and removed nearly 29 million pounds of debris and sediment. That's enough to fill nearly three Olympic-sized swimming pools.

The cleaned interceptor sewers now provide about 1.9 million gallons of extra capacity during wet weather, reducing the volume of combined sewer overflow by nearly 100 million gallons every year. This program was the first time through which DEP inspected and cleaned much of the interceptor system. DEP is working with our state regulators to develop a plan to regularly inspect and clean the system to extend these benefits into the future.



DEP crews use a Vactor truck to clean a sewer in Queens.

# PERFORMANCE METRICS

DEP uses a variety of metrics to evaluate our operations across the agency, from frontline supervisors to senior management. This data-driven approach allows us to focus our resources on managing risk and providing the highest level of service to our customers. In this section, we have collected six of the indicators presented in the various sections of this report, broken them down by borough, and described the contributing factors and trends that link them together. These charts and maps offer a snapshot into the agency's sewer operations, maintenance, and repair, and they should be considered within the broader context of the agency's operations and as counterparts to *Strategy 2011-2014*, *PlaNYC*, the annual *Mayor's Management Report*, and other publications.

## Sewer Backup Complaints

When our field crews respond to a customer call about a potential sewer backup, they first open manholes around the area where the backup or blockage is reported. If the sewer segment has higher than expected wastewater levels, the crew will note this as a "confirmed sewer backup" whether or not any backups occur. If a crew does not detect higher wastewater levels than expected, it is noted as an "unconfirmed sewer backup."

## Segments with Recurring SBUs

In order to identify systemic issues, DEP tracks street segments with recurring confirmed sewer backups—multiple backups on the same segment in the same year—during both dry and wet weather. DEP tracks both metrics because sewer backups during dry weather are more indicative of problematic areas.

## Sewer Cleaning

Sewer cleaning includes miles of sewers cleaned as part of the inspection and analysis programs, regular sewer maintenance program, and the Department of Design and Construction inspection and cleaning.

## Sewer Construction

Actual miles of sewers constructed includes capital sewer construction and reconstruction projects completed from Fiscal Year 2010 through 2012. Planned sewer construction includes projects in the capital budget for Fiscal Years 2013 and 2014.

## Confirmed Sewer Backup Causes

After visually inspecting impacted sewer segments, crews identify and record the potential cause of a confirmed sewer backup. Grease refers to the buildup of fats, oils, and grease in a sewer, while debris refers to sand, silt, and roadbed aggregate that accumulate along the bottom of the sewer. Other blockages include litter and illegally dumped trash and construction debris. The "other" category includes backups caused by collapse, temporary overtaxing by heavy rainfall, and undetermined causes.

## Industry Benchmarks

Sewer systems vary greatly in age, size, design, and use from city to city. Because of this, industry wide standards, like those in place in the water supply and wastewater treatment industries, are difficult to develop and implement across systems. Rather than one-size-fits-all standards, collection system trade groups, including the Water Environment Federation, the National Association of Clean Water Agencies, the American Public Works Association, and the American Society of Civil Engineers, have developed qualitative guidelines for effective collective system management. These include a variety of programs discussed in this report, including worker safety and training, system maintenance, hydraulic capacity assessment, system inspection, and monitoring key performance measures at all levels of the agency. DEP uses these guidelines, as well as frequent, ongoing dialogue with our regulators and other utilities, to guide us to the goal of becoming the safest, most effective, cost-efficient, and transparent water utility in the nation. Our data-driven approach to sewer maintenance and repair allows us to effectively manage risk and provide a high level of service to our customers while maximizing the use of limited resources.

# CITYWIDE

DEP's rigorous sewer inspection, analysis, and cleaning program has produced tangible improvements to the level of sewer service citywide. In the last five years, we have achieved significant improvement in many of our key indicators, demonstrating the enhanced reliability of our system.

DEP uses advanced analytical tools and a risk-management based approach to target specific locations that are most problematic. Over the last five years, we have dramatically increased the number of miles of sewers cleaned annually. We will continue to develop and refine our cleaning program to maximize the use of limited resources.

Over the last five years, total sewer backup complaints have decreased from more than 21,600 in Fiscal Year 2008 to fewer than 13,900 in 2012, a decrease of 36%. Confirmed sewer backups have decreased from more than 7,700 in Fiscal Year 2008 to just under 4,900 in 2012, a decrease of 37%. Over the last five years, the number of sewer segments with recurring backups has decreased 38%. The number of sewer segments with recurring dry weather backups also decreased 38% since Fiscal Year 2008, and in 2012, 590 sewer segments, just 0.4% of the 157,700 segments citywide, had recurring backups in dry weather.

In Fiscal Year 2012, DEP launched an in-depth analysis of sewer backup causes. This analysis indicated that 61% of confirmed sewer backups citywide were caused by commercial and residential grease buildup in the sewer. An additional 31% of backups were caused by debris and other blockages within the sewers.

In some instances, the best course of action is to repair, replace, or construct new sewer lines. Since Fiscal Year 2010, the City has built 40 miles, and has allocated resources to build 99 miles in the next two fiscal years.

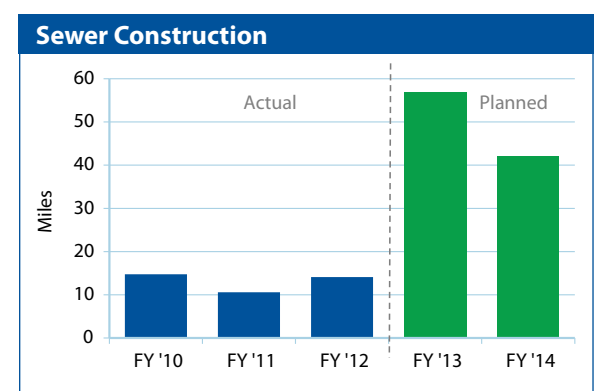
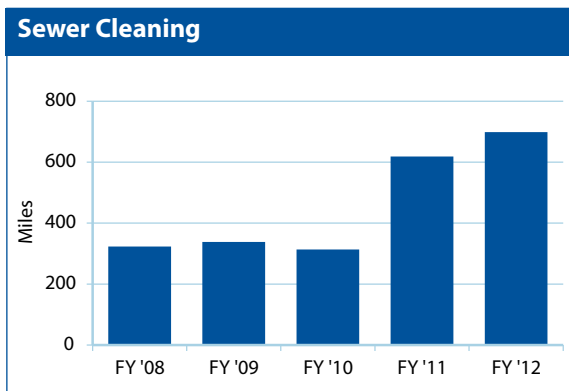
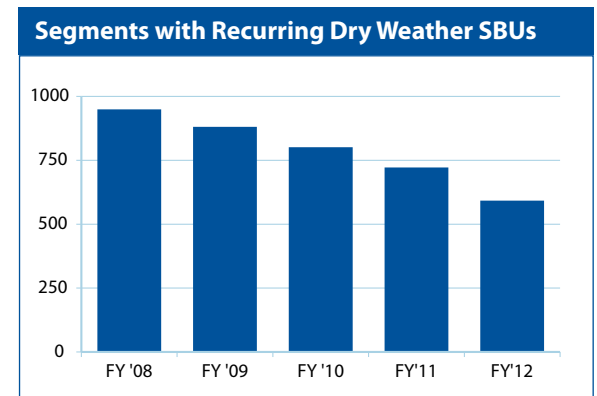
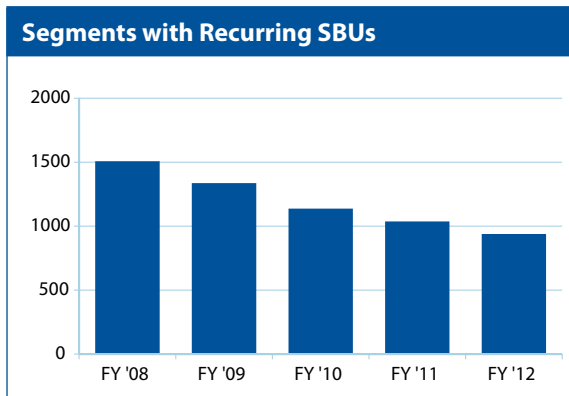
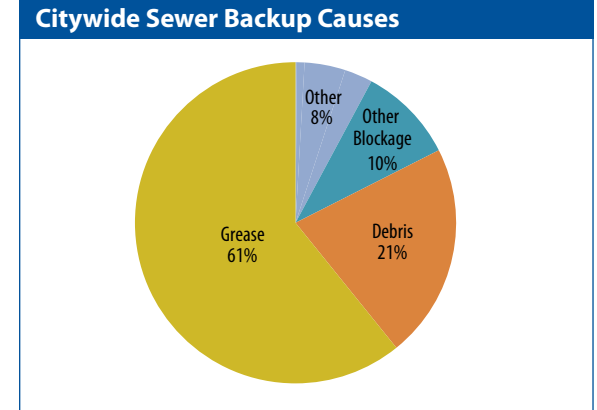
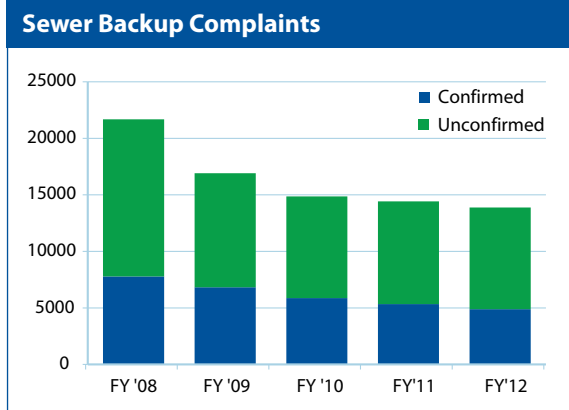

# BRONX

Over the last five years, the Bronx has shown improvement in each of the key collection system indicators. Sewer backup complaints have decreased steadily since Fiscal Year 2008, with a total decrease of 46%. The number of backups confirmed by visual inspection decreased by 58% over the same period, from 470 in Fiscal Year 2008 to 200 in 2012.

DEP has implemented advanced inspection and analysis strategies to identify areas where backups are most likely to recur, and has focused our cleaning, maintenance, and repair efforts on those areas. The number of sewer segments in the Bronx that experienced recurring sewer backups fell by 60% from Fiscal Year 2008 to 2012. The number of segments with recurring backups during dry weather also decreased by 40% over this period to just 24, 0.1% of the borough's 23,200 sewer segments.

In October 2011, DEP implemented a field checklist to determine the causes of confirmed sewer backups. Data from the first ten months of that program indicate that the primary cause of sewer backups in the borough was grease buildup, contributing to 55% of backups. To address this issue, DEP has expanded outreach about proper grease handling to co-ops, condos, and apartment buildings across the borough.

DEP also developed and launched a targeted, proactive sewer maintenance and analysis program in 2011. Through this program, annual sewer cleaning more than tripled between Fiscal Year 2008 and 2012, from 13 to 47 miles annually.

## Sewer Backup Complaints

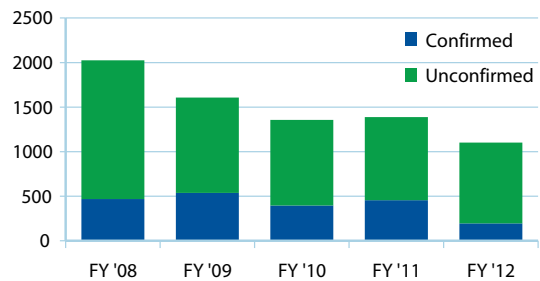

Since 2008, the number of sewer backup complaints in the Bronx has decreased by 46%.

## Recurring Backup Segments

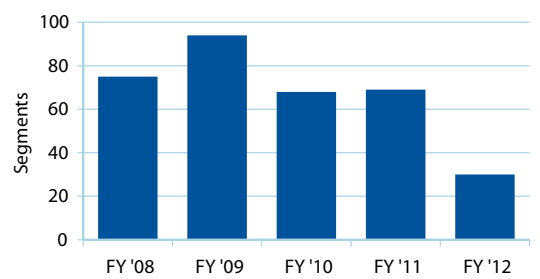

The number of segments in the Bronx with recurring sewer backups has decreased by 60% from Fiscal Year 2008.

## Sewer Cleaning

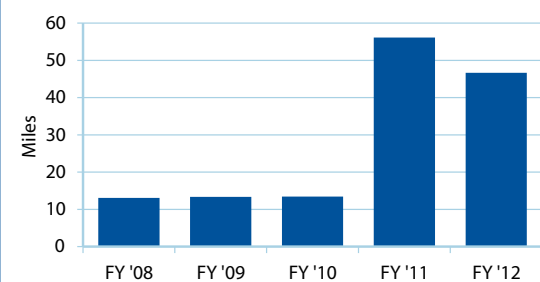

Since Fiscal Year 2008, the amount of sewer cleaned annually in the Bronx has more than tripled from 13 miles to 47 miles.

## Sewer Backup Causes

In the Bronx, grease buildup was the primary cause of 55% of confirmed sewer backups. Debris was the primary cause of another 32% of sewer backups.

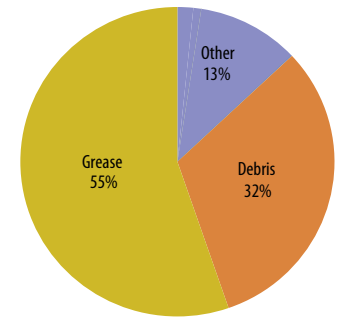

## Recurring Dry Weather Backup Segments

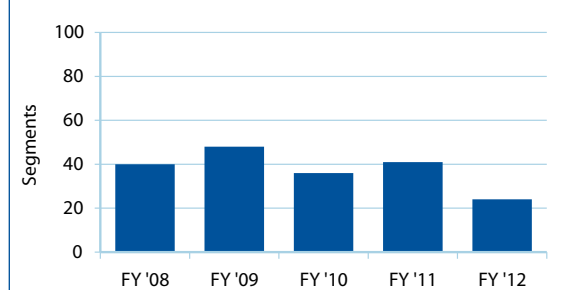

In 2012, only 24 segments experienced recurring sewer backups in dry weather, a decrease of 40% over five years.

## Sewer Construction

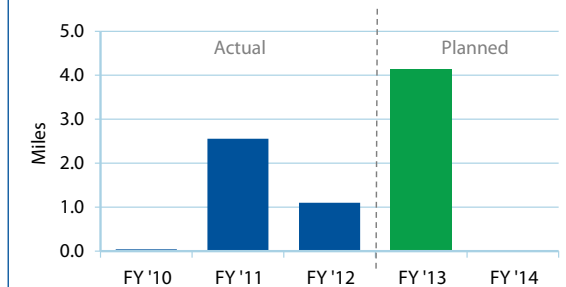

In the last three years, the City has constructed four miles of sewers with plans to build another four miles in the next two years.

# BROOKLYN

DEP uses a number of operational tools to target areas with high concentrations of dry weather sewer backups. As a result, the number of sewer segments with recurring dry weather backups fell by 53% over the past five years, and only 0.5% of the borough's 35,000 segments experienced recurring dry weather backups in Fiscal Year 2012.

Sewer backup complaints in Brooklyn decreased 38% from Fiscal Year 2008 to 2012. Backups confirmed by visual inspection of the sewer system fell even further over the same period to a total decrease of 49%. Both indicators showed a slight increase from Fiscal Year 2011 to 2012. DEP received nearly one-quarter of Brooklyn's total Fiscal Year 2012 sewer backup complaints in the month of August 2011, the wettest month on record for New York City.

In October 2011, DEP implemented a field checklist to determine the causes of confirmed sewer backups, indicating that grease buildup was the primary cause of 63% of confirmed sewer backups in Brooklyn. To address this issue, DEP community outreach representatives have gone door-to-door to restaurants in Brooklyn neighborhoods, including Brighton Beach and Bensonhurst, to distribute grease education materials.

As the sewers in many parts of Brooklyn are built out extensively, annual sewer construction and reconstruction in the borough has been lower than that in Staten Island and Queens over the past three years. In the next two years, the City plans to construct or reconstruct 11 miles of sewers.

## Sewer Backup Complaints

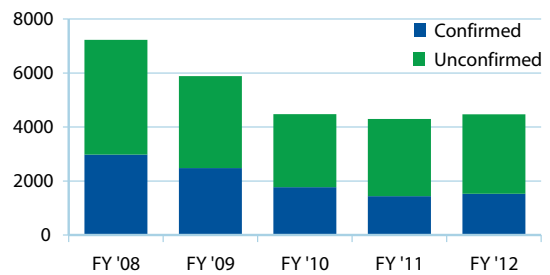

Since 2008, the total number of sewer backup complaints has decreased 38%.

## Recurring Backup Segments

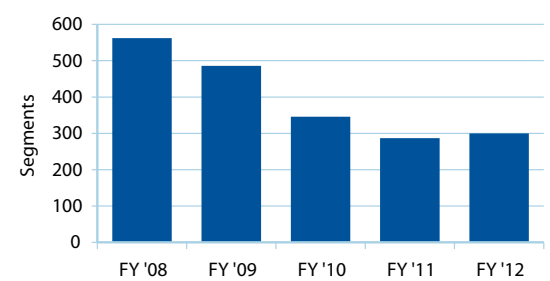

The number of segments in Brooklyn with recurring sewer backups has decreased by 47% since Fiscal Year 2008.

## Sewer Cleaning

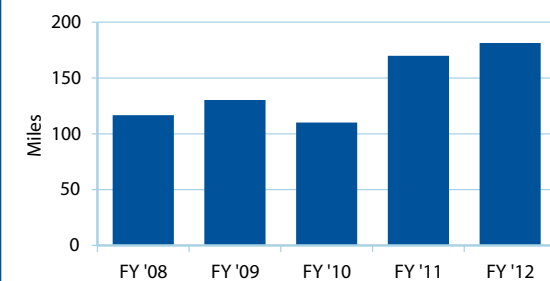

Sewer cleaning in Brooklyn increased by 56% from Fiscal Year 2008 to 2012.

## Sewer Backup Causes

In Brooklyn, grease buildup was the primary cause of 63% of confirmed sewer backups. Debris and other blockages were the primary cause of another 23% and 10% of sewer backups, respectively. Other causes, including over-taxing, represented only 4% of sewer backups.

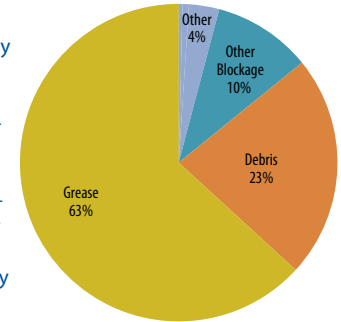

## Recurring Dry Weather Backup Segments

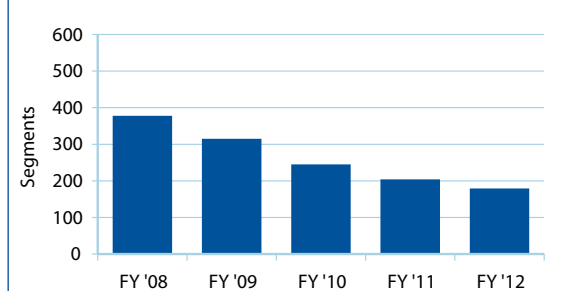

The number of segments with recurring backups in dry weather has decreased 53% since Fiscal Year 2008.

## Sewer Construction

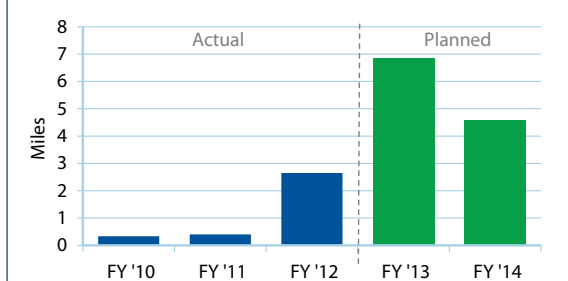

Since 2012, the City has constructed three miles of sewers and plans to build 11 miles in Fiscal Years 2013 and 2014.



# MANHATTAN

Over the past five years, Manhattan has shown improvement across all key indicators. Sewer backup complaints have decreased 36%, from Fiscal Year 2008 to 2012. Likewise, confirmed sewer backups have decreased 16%. The number of segments with recurring dry weather backups leveled out in Fiscal Year 2012 at 26, 0.2% of 15,800 segments and a 7% decrease from 2008.

Similar to citywide results, data from DEP's field checklist for sewer backups indicate that grease is the main contributor to sewer backups, identified as a cause in 54% of backups. DEP has expanded outreach to residents and businesses throughout the borough, including holding grease trap compliance workshops in the Meatpacking District, Midtown, and Washington Heights. DEP has also increased sewer cleaning operations in Manhattan, more than doubling the miles cleaned from seven in Fiscal Year 2008 to 19 in 2012.

Because the sewer system in Manhattan has been extensively built out to accommodate dense development, the City has built less than half a mile of sewers since Fiscal Year 2010. Although an additional two miles are planned by Fiscal Year 2014, DEP has focused sewer construction efforts in other areas of the City, particularly Queens and Staten Island.

## Sewer Backup Complaints

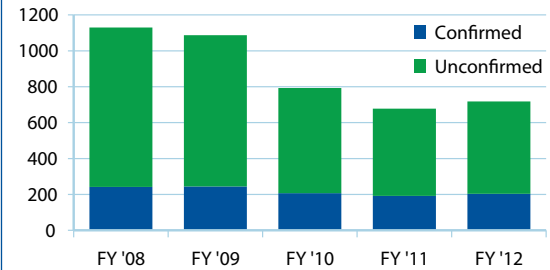

Since 2008, the total number of sewer backup complaints in Manhattan has decreased by 57%.

## Recurring Backup Segments

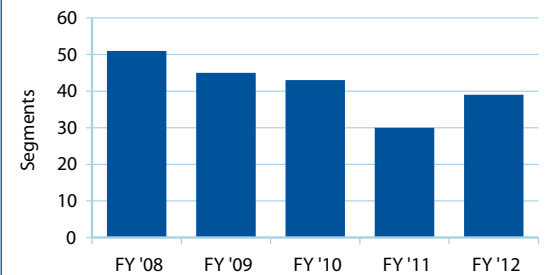

The number of segments in Manhattan with recurring sewer backups has decreased by 31% since Fiscal Year 2008.

## Sewer Cleaning

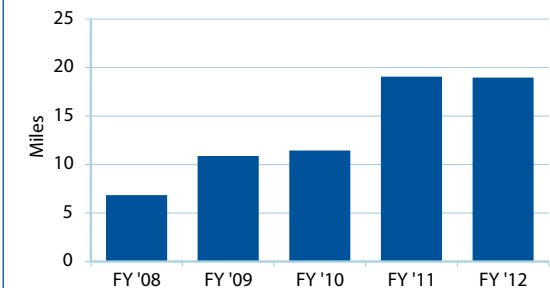

DEP has more than doubled sewer cleaning mileage from seven miles in Fiscal Year 2008 to 19 miles in Fiscal Year 2012.

## Sewer Backup Causes

In Manhattan, grease was the primary cause of 54% of confirmed sewer backups, while debris and other blockages accounted for 14% and 21% of sewer back up causes, respectively.

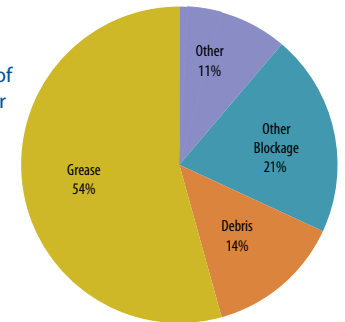

## Recurring Dry Weather Backup Segments

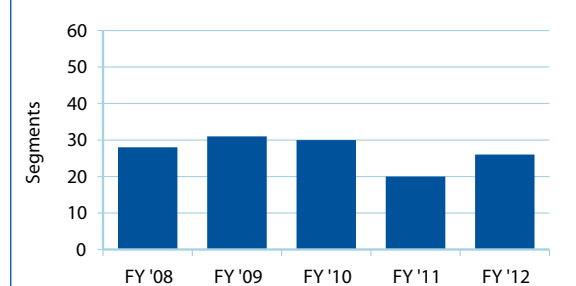

The number of segments with recurring sewer backups in dry weather has stayed level since 2008.

## Sewer Construction

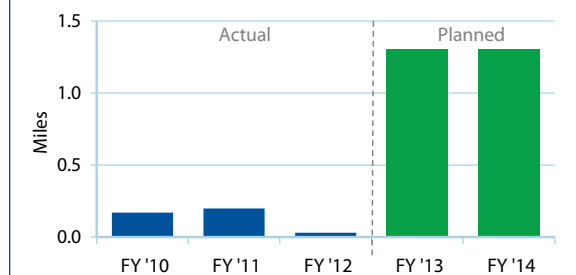

Since Fiscal Year 2010, DEP has built less than half a mile of sewers and plans to build two miles by Fiscal Year 2014.

# QUEENS

Queens presents unique challenges for DEP in addressing confirmed sewer backups. In some neighborhoods, development outpaced the expansion of the sewer system, and in others high groundwater tables and varying topography can be problematic. Through the use of risk assessment and management, DEP efficiently employs resources to improve service for customers boroughwide.

Total sewer backup complaints in Queens decreased 43% from Fiscal Year 2008 to 2012. The number of backups confirmed by visual inspection decreased by 39% over the same period. The number of segments with recurring dry weather backups decreased by 34% from Fiscal Year 2008 to 2012 to 279, 0.4% of the borough's 62,000 segments.

Fats, oils, and grease caused 63% of all confirmed sewer backups in Queens, according to a field checklist in place since October 2011. DEP has conducted targeted grease education for businesses in many neighborhoods, including Forest Hills, Downtown Flushing, and Jamaica. In addition, DEP more than doubled annual sewer cleaning in the borough between Fiscal Year 2008 and 2012.

Queens continues to receive the largest investment in new and reconstructed sewers. Since 2010 the City has invested more than \$100 million to construct or reconstruct 17 miles of sewer, and the City plans to build 36 miles of sewers in Fiscal Years 2013 and 2014. In 2011, DEP completed construction of the borough's first Bluebelt at Oakland Lake Park, the first of many sustainable stormwater management practices planned for the borough.

## Sewer Backup Complaints

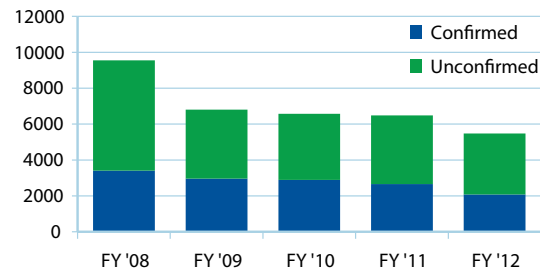

The total number of sewer backup complaints has decreased 43% since Fiscal Year 2008.

## Recurring Backup Segments

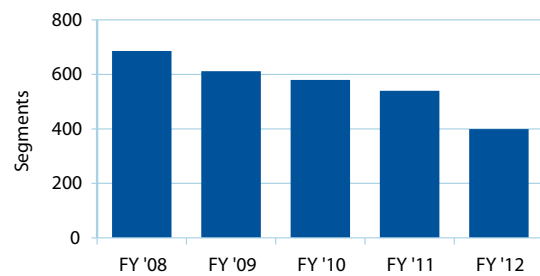

The number of sewer segments in Queens with recurring backups has decreased by 42% since Fiscal Year 2008.

## Sewer Cleaning

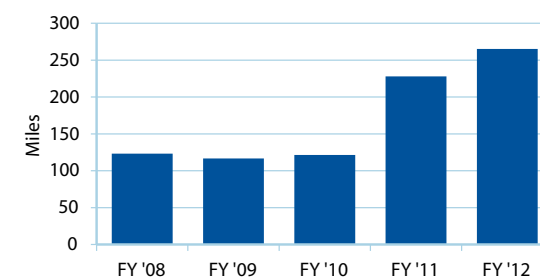

Sewer cleaning in Queens increased by 115% from Fiscal Year 2008 to 2012.

## Sewer Backup Causes

In Queens, grease buildup was the primary cause of 63% of confirmed sewer backups. Debris and other blockages were the primary cause of another 23% and 10% of sewer backups, respectively. Other causes, including over-taxing, represented only 4% of sewer backups.

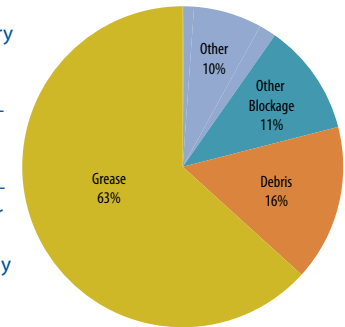

## Recurring Dry Weather Backup Segments

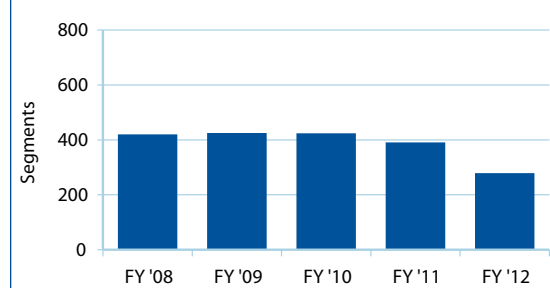

The number of sewer segments with recurring backups in dry weather has decreased 34% since Fiscal Year 2008.

## Sewer Construction

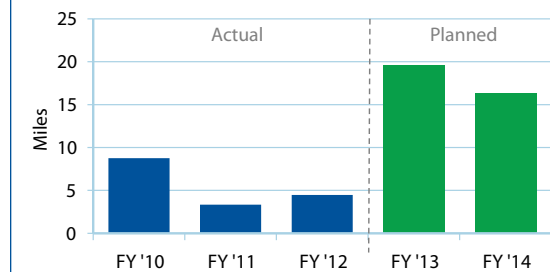

In the last three years, the City has constructed 17 miles of sewers with plans to build another 36 miles in the next two years.

# STATEN ISLAND

Over the last five years, DEP has deployed resources to target areas of the sewer system in Staten Island with high concentrations of sewer backups. Over the last five years, the number of segments with recurring dry weather backups has stayed level, and 84 segments, 0.4% of Staten Island's 21,700 sewer segments, had recurring dry weather backups in Fiscal Year 2012.

Total sewer backup complaints declined between Fiscal Year 2008 and 2011, from 1,740 to 1,580, but increased in 2012 to 2,110. Although sewer backup complaints in Fiscal Year 2012 increased 21% over the five year period, nearly one-third of all Staten Island sewer backup complaints for Fiscal Year 2012 were received in August 2011—the same month that the City received a record 17 inches of rainfall.

In October 2011, DEP implemented a field checklist to determine the causes of confirmed sewer backups. In the first ten months of the program, data confirmed that grease buildup is the primary cause of 51% of all backups in Staten Island. To address this, DEP has dramatically increased sewer cleaning in Staten Island, from 56 miles in 2008 to more than 168 miles in 2012, an increase of 183%.

Many parts of Staten Island lack a fully built sewer network, and DEP continues to build out the system. Over the last three years, DEP invested heavily in Staten Island's sewers. From Fiscal Year 2010 to 2012, the City built 15 miles of sewers, 38% of all sewers built citywide. Over the next two years, the City plans to build 44 miles of sewers for Staten Island, 45% of all sewers planned over that period citywide. In addition, DEP has constructed more than 60 Bluebelts in the borough, providing stormwater management for 12,000 acres of land.

## Sewer Backup Complaints

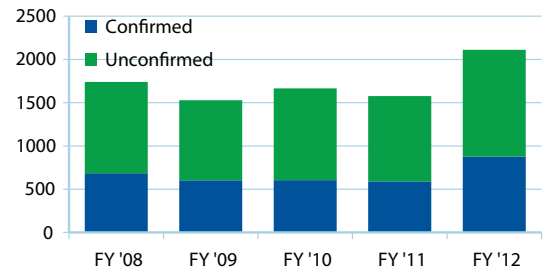

Since 2008, the total number of sewer backup complaints in Staten Island has increased by 21%.

## Recurring Backup Segments

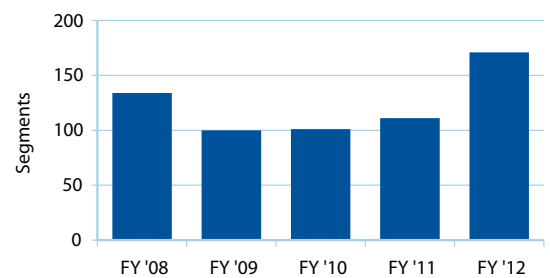

The number of segments with recurring sewer backups has increased by 28% from Fiscal Year 2008 to 2012.

## Sewer Cleaning

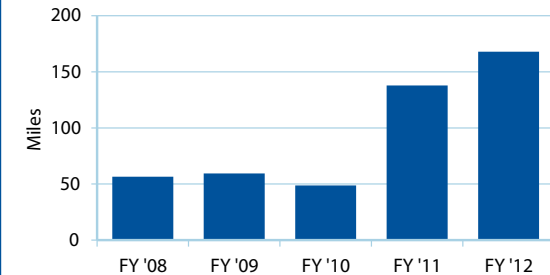

DEP has dramatically increased sewer cleaning, from 56 miles in 2008 to more than 168 in 2012, an increase of 197%.

## Sewer Backup Causes

In Staten Island, grease buildup was the primary cause of 51% of confirmed sewer backups. Debris was the primary cause of another 41% of sewer backups. All other causes, including overtaxed or collapsed sewers, represented only 8% of all backups.

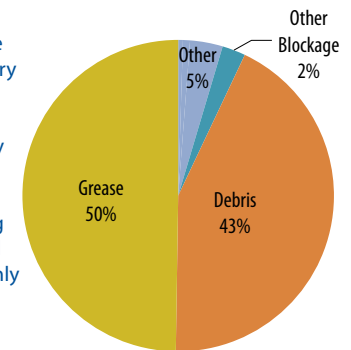

## Recurring Dry Weather Backup Segments

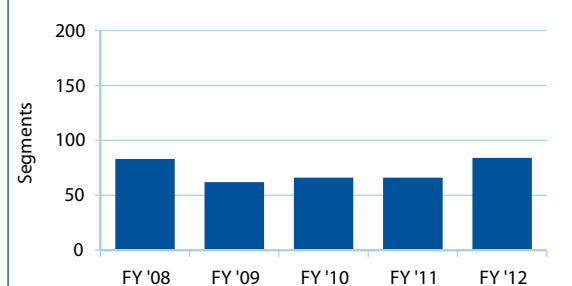

The number of segments with recurring sewer backups in dry weather has not changed considerably since Fiscal Year 2008.

## Sewer Construction

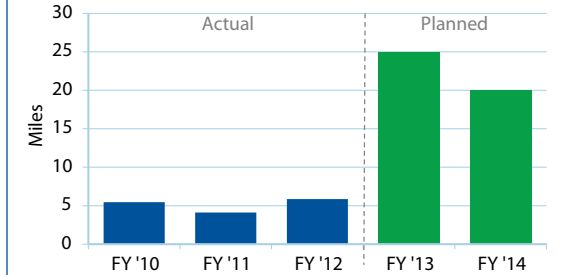

Since 2010, the City has constructed nine miles of sewers with plans to build another 44 miles over the next two years.

# CONCLUSION

Over the past several years, DEP has had considerable success implementing new and innovative programs to run our sewer system better and more effectively than ever before. Yet, even with these promising trends, we know there is more to be done.

To build on our progress, we will continue to develop our Capacity, Management, Operations, and Maintenance section, strategically devoting resources to problematic areas. We will pilot new technologies—both for our field crews and our analysts—and implement those that perform well. And as always, we will continue to work with our partner utilities across the country to ensure that regulatory decisions are made that help us run our system smarter and more efficiently.

To be sure, we will face new challenges, including the likelihood of more brief, intense storms as a result of climate change and increased demands on our system by a growing population. To address these new challenges, DEP has a wide breadth of solutions at the ready. In 2010, the City released the NYC Green Infrastructure Plan to incorporate bioswales, blue roofs, green roofs, and subsurface detention systems into the fabric of the city's infrastructure. These systems will reduce the strain on the combined sewer system by detaining and diverting stormwater during wet weather while adding many quality of life benefits, including improved air quality and greener streets. Not only does this plan achieve greater environmental benefits than a traditional plan consisting of large storage tanks that are only useful when

it rains, but the City can implement the NYC Green Infrastructure Plan for billions less.

Over the last year, DEP has also brought the award-winning Bluebelt program to parts of the Bronx and Queens where the technology proves more cost-effective than traditional sewer expansions. In addition to the 60 Bluebelts we already have completed, we have another 30 Bluebelts at some stage of design or construction that will alleviate flooding conditions, increase drainage, and improve the quality of life of many New Yorkers.

These types of innovative solutions, paired with an optimized sewer system, will propel New York City to the forefront of stormwater management.





**Environmental  
Protection**

Michael R. Bloomberg, Mayor  
Carter H. Strickland, Jr., Commissioner