

TABLE OF CONTENTS

Section Definitions

P101.0 General Provisions

- P101.1 Protection of Pipes
- P101.2 Trenching, Excavation, and Backfill
- P101.3 Sleeves
- P101.4 Ratproofing
- P101.5 Toilet Facilities for Workmen

P102.0 Materials

- P102.1 General Requirements
- P102.2 Standards for Plumbing Materials
- P102.3 Identification Materials
- P102.4 Piping System Materials

P103.0 Joints and Connections

- P103.1 Types of Joints for Piping Materials
- P103.2 Joints Between Different Piping Materials
- P103.3 Connections Between Drainage Piping and Certain Fixtures
- P103.4 Tightness
- P103.5 Waterproofing of Openings
- P103.6 Other Joints

P104.0 Plumbing Fixtures

- P104.1 Requirements
- P104.2 Installation of Fixtures
- P104.3 Overflows
- P104.4 Water Closets
- P104.5 Urinals
- P104.6 Flushing Devices for Water Closets and Urinals
- P104.7 Lavatories
- P104.8 Bathtubs
- P104.9 Showers
- P104.10 Sinks
- P104.11 Dishwashing Machines
- P104.12 Automatic Clothes Washers
- P104.13 Laundry Trays
- P104.14 Garbage Can Washers
- P104.15 Fixture Strainers
- P104.16 Drinking Fountains
- P104.17 Floor Drains
- P104.18 Drains for Drip Pipes
- P104.19 Funnel Drains
- P104.20 Special Plumbing Fixtures

P105.0 Traps and Cleanouts

- P105.1 Fixture Traps
- P105.2 Building (House) Traps
- P105.3 Drainage Pipe Cleanouts
- P105.4 Interceptors, Separators, and Neutralizing Pits
- P105.5 Interceptors, Separators, and Neutralizing Pits for Specific Services
- P105.6 Venting of Interceptors, Separators, and

Neutralizing Pits

- P105.7 Accessibility of Interceptors, Separators and Neutralizing Pits
- P105.8 Maintenance of Interceptors, Separators and Neutralizing Pits
- P105.9 Backwater Valves
- P105.10 Industrial Wastes Sampling Manholes

P106.0 Hangers and Supports

- P106.1 Material
- P106.2 Attachment to Building
- P106.3 Intervals of Supports
- *P106.4 Installation of No-Hub Type Cast Iron Soil Pipe, Fittings, and Couplings

**Local Law 100-1989*

P107.0 Water Supply and Distribution

- P107.1 Permits
- P107.2 Water Service
- P107.3 Meters
- P107.4 Check Valves
- P107.5 Water Supply Distribution System
- P107.6 Water Supply Control Valves
- P107.7 Auxiliary Water Systems
- P107.8 Water Supply Tanks
- P107.9 House and Booster Pumps
- P107.10 Protection of Potable Supply
- P107.11 Toxic Materials and Substances
- P107.12 Used Piping
- P107.13 Prohibited Connections to Fixtures and Equipment
- P107.14 Connections to Mechanical Equipment and Systems
- P107.15 Refrigeration Unit Condensers and Cooling Jackets
- P107.16 Air Conditioning and Refrigeration
- P107.17 Used Water Return Prohibited
- P107.18 Protection Against Backflow and Back-Siphonage
- P107.19 Approval of Devices
- P107.20 Protection of Potable Water Supply Outlets
- P107.21 Preheating Apparatus
- P107.22 (Blank)
- P107.23 Chemical Solution Tanks or Apparatus
- P107.24 Bedpan Washers
- P107.25 Laboratory Outlets
- P107.26 Hot Water Supply System
- P107.27 Disinfection of Potable Water Systems

P108.0 Sanitary Drainage Piping

- P108.1 Permits
- P108.2 Street Sewer Connections
- P108.3 Abandonment of Existing Building Sewer Connections

Reference Standard 16

- P108.4 Building (House Traps)
- P108.5 Fresh Air Inlets
- P108.6 Drainage Below Sewer Level
- P108.7 Sub-Soil Drainage
- P108.8 Drainage Piping Installation
- P108.9 Sanitary Drainage Fixture Units
- P108.10 Sizing the Sanitary Drainage Piping
- P108.11 Drip Pipes

P109.0 Vent Piping

- P109.1 Size of Vents
- P109.2 Protection of Trap Seals
- P109.3 Vent Stack and Stack Vents
- P109.4 Vent Terminals
- P109.5 Vent Grading and Connections
- P109.6 Stack Venting
- P109.7 Common Vents
- P109.8 Fixture Vents
- P109.9 Relief Vents
- P109.10 Suds Pressure Zones Vents
- P109.11 Permitted Combination Waste and Vent Systems

P110.0 Storm Drainage Piping

- P110.1 Permits
- *P110.2 Disposal of Storm Water
- P110.3 Storm Water Drainage to Sanitary Sewer Prohibited
- P110.4 Size of Storm Drains and Leaders
- P110.5 Values for Continuous Flow
- P110.6 Controlled Flow Storm Water System
- P110.7 Traps on Storm Drains and Leaders
- P110.8 Leaders or Storm Water Piping
- P110.9 Roof Drain Strainers
- P110.10 Roof Drain Flashings Required
- P110.11 Expansion Joints Required
- P110.12 Sanitary and Storm Sewers
- *P110.13 On-Site Disposal
- *Local Law 103-1989; Local Law 7-1984*

P111.0 Indirect Waste Piping

- P111.1 Indirect Waste Required
- P111.2 Common Indirect Wastes
- P111.3 Venting
- P111.4 Sizing
- P111.5 Receptors or Sumps
- P111.6 Condensers and Sumps

P112.0 Special and Miscellaneous Waste Piping

- P112.1 Industrial Wastes
- P112.2 Chemical Wastes
- P112.3 Flammable Solvents or Oil Wastes
- P112.4 Radioactive Wastes

P113.0 Individual Sewage Systems

- P113.1 Information Required
- P113.2 Individual Sewage Disposal Systems

- P113.3 Individual Sewage Disposal System (One and Two-Family Dwellings)
- P113.4 Housing Development Sewage Disposal Systems
- P113.5 General Requirements
- P113.6 Location
- P113.7 Septic Tanks
- P113.8 Distribution Box
- P113.9 Soil Percolation Tests
- P113.10 Seepage Units
- P113.11 Subsurface Disposal Field
- P113.12 Maintenance

P114.0 Hospital and Institutional Plumbing

- P114.1 General
- P114.2 Definitions for Special Hospital Fixtures and Equipment
- P114.3 Requirement for Special Hospital Fixtures and Equipment
- P114.4 Plumbing in Mental Hospitals
- P114.5 Number of Plumbing Fixtures
- P114.6 Drainage and Venting
- P114.7 Sterilizer Wastes
- P114.8 Vapor Vents
- P114.9 Sizing of Sterilizer Vent Stacks
- P114.10 Water Supply
- P114.11 Vacuum Systems
- P114.12 Oxygen and Nitrous Oxide Systems

P115.0 Gas Piping

- P115.1 General Requirements for Gas Piping
- P115.2 Gas Service Piping Connections
- P115.3 Gas Regulator and Gas Regulator Vent Outlets
- P115.4 Outside Gas Cut-Off
- P115.5 Gas Meter Location
- P115.6 Gas Piping Materials and Fittings
- P115.7 Installation of Gas Piping
- P115.8 Gas Piping Sizes

P116.0 Swimming Pools and Display Pools or Fountains

- P116.1 Swimming Pools
- P116.2 Display Pools and Fountains

LIST OF TABLES

Index Table No.

- RS 16-1 Standards for Plumbing Materials
- RS 16-2 Deleted
- RS 16-3 Caulking Ferrules
- RS 16-4 Soldering Bushings
- RS 16-5 Minimum Number of Plumbing Fixtures Required
- RS 16-6 Minimum Size of Fixture Traps for Various Types of Plumbing Fixtures
- RS 16-7 Minimum Rate of Flow and Minimum Required Pressure During Flow for Sizing Individual Branch Supplies for Plumbing Fixtures
- RS 16-8 Size of Overflows for Gravity and Suction

Reference Standard 16

- Tanks
- RS 16-9 Size of Weirs for Gravity and Suction Tanks
- RS 16-10 Suction Tank Sizes
- RS 16-11 Cross-Connection Where Protective Devices are Required and Critical Level (C-L) Setting for Vacuum Breakers
- RS 16-12 Sanitary Drainage Fixture Unit Valves
- RS 16-13 Maximum Permissible Loads for Sanitary Drainage Piping (in terms of fixture units)
- RS 16-14 Size of Vent Stacks and Branch Vents
- RS 16-15 Deleted
- RS 16-16 Deleted
- RS 16-17 Size of Horizontal Storm Drains
- RS 16-18 Size of Vertical Leaders
- RS 16-19 Size of Roof Gutters*
- *Local Law 85-1973*
- RS 16-20 Fixture Unit-Drainage Square Footage Equivalent
- RS 16-21 Minimum Distances Between Sewage System Components and Between Components and Encumbrances
- RS 16-22 Minimum Capacity of Septic Tanks
- RS 16-23A Design Data for Absorptive Capacity of Disposal Field and Seepage Pits
- RS 16-23B Design Data for Absorptive Capacity of Disposal Field and Seepage Pits
- RS 16-24 Limiting Dimensions of Disposal Field Components
- RS 16-25 Minimum Number of Fixtures for Hospitals and Institutions
- RS 16-26 Stack Sizes for Bedpan Steamers and Boiling Type Sterilizers, and of Connections Permitted
- RS 16-27 Stack Sizes for Pressure Sterilizers and Number of Connections Permitted
- RS 16-28 Fixture Water Supply Protection

LIST OF ILLUSTRATIONS

Figure No.

- RS 16-1 Methods of Connecting Overflow from Gravity House and Suction Water Supply Tanks
- RS 16-2 Sizing of Branch Vent Piping and Drop Vents to First Floor, Basement and Cellar Fixtures
- RS 16-3 Deleted
- RS 16-4 Vent Arrangements
- RS 16-5 Deleted
- RS 16-6 Offsets in Buildings Five Stories or More
- RS 16-7 Relief Vents for Stack of More than Ten Branch Intervals
- RS 16-8 Suds Pressure Zones
- RS 16-9 Combination Waste and Vent Oil Waste Drainage
- **RS 16-9A Yard Drain With Sump
- **RS 16-9B Detail of Dry Well With Sand Column
- RS 16-10 Acid Drainage for Buildings Four Stories or Less

RS 16-11 Acid Drainage for Buildings Over Four Stories

*RS 16-12A Typical Concrete Septic Tank

*RS 16-12B Typical Metal Septic Tank

*RS 16-13A Absorption Type System

*RS 16-13B Absorption Type

**Local Law 85-1973*

***Local Law 103-1989*

Section P100.0 Definitions

The following definitions shall be used in the application of this reference standard.

AIR-BREAK (DRAINAGE SYSTEM).—A piping arrangement in which a drain from a fixture, appliance, or device discharges through an air break into a fixture, receptacle, or interceptor at a point above the flood level rim of the receptacle.

AIR GAP (WATER DISTRIBUTION SYSTEM).—The unobstructed vertical distance through the free atmosphere between the lowest opening from any pipe or faucet supplying water to a tank, plumbing fixture, or other device and the flood level rim of the receptacle.

BACKFLOW.—The flow of water or other liquids, mixtures, or substances into the distributing pipes of a potable supply of water from any source or sources other than its intended source. (See back-siphonage.)

BACK-SIPHONAGE.—The flowing back of used, contaminated, or polluted water from a plumbing fixture or vessel into a water-supply system due to a negative pressure in such pipe. (See backflow.)

BATTERY OF FIXTURES.—Any group of two or more similar adjacent fixtures that discharge into a common horizontal waste or soil branch.

BRANCH.—That part of a piping system other than a main, riser, or stack that extends to fixtures on two or less consecutive floors.

BRANCH INTERVAL.—A distance along a soil or waste stack corresponding in general to a story height, but in no case less than 8 ft. within which the horizontal branches from one floor or story of a building are connected to the stack.

BRANCH VENT.—A vent connecting one or more individual vents with a vent stack or stack vent.

BUILDING HOUSE DRAIN.—That part of the lowest piping of a drainage system that receives the discharge from the soil, waste, and other drainage pipes of the building and conveys it to the building house sewer by gravity; the building house drain shall be considered to extend 5 ft. outside the building wall.

BUILDING HOUSE DRAIN (COMBINED).—A building house drain that conveys both storm water and sewage or other drainage.

BUILDING HOUSE DRAIN (SANITARY).—A building house drain carrying sewage only.

BUILDING GRAVITY DRAINAGE SYSTEM.—A drainage system that drains by gravity into the

Reference Standard 16

building house sewer.

BUILDING HOUSE SEWER.—That part of the horizontal piping of a drainage system that extends from the end of the building house drain and that receives the discharge of the building house drain and conveys it to a public sewer, private sewer, individual sewage-disposal system or other point of disposal.

BUILDING HOUSE SEWER (COMBINED).—A building house sewer that conveys both sewage and storm water and other clear water wastes.

BUILDING HOUSE SEWER (SANITARY).—A building house sewer carrying sewage only.

BUILDING HOUSE STORM DRAIN.—That part of the lowest piping of a storm drainage system that receives clear water drainage from leaders, surface run-off, ground water, subsurface water, condensate, cooling water or other similar storm or clear water drainage pipes inside of the walls of the building and conveys to it to the building house storm sewer by gravity; the building house storm drain shall be considered to extend 5 ft. outside of the building wall.

BUILDING HOUSE STORM SEWER.—That part of the horizontal piping of the storm drainage system that extends from the building house storm drain to the public storm sewer, combined sewer, or other point of disposal.

BUILDING SUB-HOUSE DRAIN.—The portion of a house drainage system that conveys the drainage from the lower portion of the building to an ejector pit or sump pit from which it is pumped into the building house sewer.

BUILDING HOUSE TRAP.—A trap, or assembly of fittings, installed in the building house drain to prevent circulation of air between the house drainage system and the building house sewer.

CESSPOOL.—A covered excavation in the ground that receives the discharge of domestic sewage or other organic wastes from a drainage system, so designed as to retain the organic matter and solids, but permitting the liquid to seep through the bottom and sides.

COMBINATION FIXTURE.—A fixture combining one sink and tray or two- or three-compartment sink or tray in one unit.

COMBINATION WASTE AND VENT SYSTEM.—A specially designed system of waste piping embodying the horizontal wet venting of one or more sinks or floor drains by means of a common waste and vent pipe.

COMMON VENT.—A vent connecting at the junction of two fixture drains and serving as a vent for both fixtures and drains.

CONTINUOUS VENT.—A vertical vent that is a continuation of the drain to which it connects.

CONTINUOUS WASTE.—A drain from two or three fixtures connected to a single trap.

CROSS-CONNECTION.—A physical connection

or arrangement between two otherwise separate piping systems, one of which contains potable water and the other with either water of unknown or questionable safety or steam, gases, or chemicals whereby there can be a flow from one system to another.

DEAD END.—A branch leading from a soil, waste, or vent pipe, building house drain, or building house sewer, which is terminated to a developed distance of 2 ft. or more by means of a plug or other closed fitting.

DEVELOPED LENGTH.—The length along the center line of pipe and fittings, both horizontal and vertical.

DIAMETER.—Unless otherwise specifically stated, the term "diameter" is the nominal diameter as designated commercially.

DOMESTIC SEWAGE.—The water-borne wastes derived from ordinary living processes.

DRAIN.—Any pipe that carries waste water or water-borne wastes in a building drainage system.

DRAINAGE SYSTEM.—Includes all the piping within public or private premises, which conveys sewage, rain water, or other liquid wastes to a legal point of disposal, but does not include the mains of a public sewer system or private or public sewage-treatment or disposal plant.

DRY WELL.—See leaching well or pit.

DUAL VENT.—See common vent.

EFFECTIVE OPENING.—The minimum cross-sectional area at the point of water-discharge, measured or expressed in terms: (1) diameter of a circle; (2) if the opening is not circular, the diameter or a circle of equivalent cross-sectional area.

EXISTING WORK.—A plumbing system or any part thereof installed prior to the effective date of this code.

FIRE LINE.—A system of pipes and equipment used exclusively to supply water for extinguishing fires.

FIXTURE.—See plumbing fixture.

FIXTURE BRANCH.—A water supply pipe connecting one or more fixtures to a main water supply header or riser.

FIXTURE DRAIN.—The drain from the trap of a fixture to the junction of that drain with any other drain pipe.

FIXTURE SUPPLY.—A water-supply pipe connecting the fixture with the fixture branch.

FLOOD LEVEL RIM.—The top edge or rim of a receptacle from which water can overflow regardless of the location of any overflow piping from the receptacle.

FLOODED.—A fixture is flooded when the liquid therein rises to the flood level rim.

FLUSH VALVE.—A device located at the bottom of the tank for the purpose of flushing water closets and similar fixtures.

FLUSHMETER VALVE.—A device that discharges a predetermined quantity of water to fixtures

Reference Standard 16

for flushing purposes and is actuated by direct water pressure.

FROSTPROOF WATER CLOSET.—A hopper that has no water in the bowl and has the trap and the control valve for its water supply installed below the frost line.

GAS DISTRIBUTION PIPING.—All piping from the house wide of the gas meter piping that distributes the gas supplied by a public utility to all fixtures and apparatus used for illumination or fuel in any building

GAS METER PIPING.—The piping from the shut-off valve inside the building to the outlet of the meter.

GAS SERVICE PIPING.—The supply pipe from the street main through the building wall and including the stopcock or shut-off valve inside the building.

INDIRECT WASTE PIPE.—A drain pipe used to convey liquid wastes that does not connect directly with the drainage system, but which discharges into the house drainage system through an air break into a trap, fixture, receptacle, or interceptor.

INDUSTRIAL WASTE.—A liquid, gaseous or solid substance, or a combination thereof resulting from any process of industry, manufacturing, trade or business or from the development or recovery of any natural resource.

INTERCEPTOR.—A device designed and installed so as to separate and retain deleterious, hazardous, or undesirable matter from normal wastes and permit normal sewage or liquid wastes to discharge into the disposal terminal by gravity.

LEACHING WELL OR PIT.—A covered pit constructed so as to permit the liquid contents to seep into the ground.

LEADER.—A vertical drainage pipe for conveying storm water from roof or gutter drains to the building storm drain, building house drain (combined), or other means of disposal. The leader shall include the horizontal pipe to a single roof drain or gutter drain.

LIQUID WASTE.—The discharge from any fixture, appliance, or appurtenance, in connection with a plumbing system that does not receive fecal matter.

LOAD FACTOR.—The percentage of the total connected fixture unit flow rate that is likely to occur at any point in the drainage system.

LOCAL VENTILATING PIPE.—A pipe on the fixture side of the trap through which vapor or foul air is removed from a room or fixture.

NORMAL SEWAGE.—Normal sewage means "normal sewage" as defined in the rules and regulations of the Department of Public Works.

PITCH.—See grade.

pH VALUE.—An arbitrary symbol adopted to express the degree of acidity or alkalinity of a solution. It is the logarithm of the reciprocal of the hydrogenion concentration, in gram mols per liter at 71.6°F. A pH of 7.0 represents a neutral solution, lower values represent acidity, higher values alkalinity.

PIPING.—As used in this reference standard, piping shall include fittings, valves, and other accessories or appurtenances required to make a complete installation.

PLUMBING.—The practice, materials, and fixtures used in the installation, maintenance, extension, repair, replacement, relocation and alteration of all piping, fixtures, appliances, and appurtenances in connection with any of the following, sanitary drainage or storm drainage facilities, the venting system, and public or private water supply systems, within or adjacent to any building; also, the practice and materials used in the installation, maintenance, extension, repair, replacement, relocation or alteration of storm water, liquid-waste, or sewerage, and water-supply systems of any premises in their connection with any point of public disposal or other acceptable terminal.

PLUMBING FIXTURES.—Installed receptacles, devices, or appliances that are supplied with water or that receive or discharge liquids or liquid-borne wastes.

PLUMBING SYSTEM.—Includes the water-supply and distribution pipes; plumbing fixtures and traps; soil, waste, and vent pipe; building house drains and building house sewers including their respective connections, devices, and appurtenances within the property lines of the premises, and water-treating or water-using equipment.

POOL.—A water receptacle used for swimming or as a plunge or other bath, designed to accommodate more than one bather at a time. Also a receptacle used for decorative purposes.

POTABLE WATER.—Water free from impurities present in amounts sufficient to cause disease or harmful physiological effects. Its bacteriological and chemical quality shall conform to the requirements of the department of health of the City of New York.

PRIVATE OR PRIVATE USE.—In the classification of plumbing fixtures, "private" applies to fixtures in residences and apartments and to fixtures in bathrooms of hotels and similar installations where the fixtures are intended for the use of a family or an individual.

PRIVATE SEWER.—A sewer privately owned and controlled by public authority only to the extent provided by law.

PUBLIC OR PUBLIC USE.—In the classification of plumbing fixtures, "public" applies to fixtures in general toilet rooms of schools, gymnasiums, hotels, railroad stations, public buildings, bars, comfort stations, and other installations (whether pay or free) where fixtures are installed so that their use is similarly unrestricted.

PUBLIC SEWER.—A common sewer directly controlled by public authority.

RELIEF VENT.—A vent installed so as to permit additional circulation of air between the drainage and vent systems where the drainage system might otherwise be air bound.

RIM.—An unobstructed open edge of a fixture.

Reference Standard 16

RISER.—A water-supply pipe that extends vertically one full story or more to convey water to branches or fixtures.

ROOF DRAIN.—A drain installed to receive water collecting on the surface of a roof and to discharge it into the leader (downspout).

ROUGHING-IN.—The installation of all parts of the plumbing system that can be completed prior to the installation of fixtures. This includes drainage, water-supply, and vent piping, and the necessary fixture supports.

SANITARY SEWAGE.—See domestic sewage.

SANITARY SEWER.—A pipe that carries sewage and excludes storm, surface and ground water.

SEEPAGE PITS OR WELLS.—A covered pit with open jointed or perforated lining into which the septic tank effluent is discharged. The liquid portion of the sewage seeps into the surrounding porous soil. The remaining solids or sludge is retained in the pit.

SEPARATOR.—See interceptor.

SEPTIC TANK.—A watertight receptacle that receives the discharge of a drainage system or part thereof, and is designed and constructed so as to separate solids from the liquid, digest organic matter during a period of detention, and allow the liquids to discharge into the soil outside of the tank through a system of open-joint or perforated piping, or seepage pit.

SEWAGE.—Any liquid waste containing animal or vegetable matter in suspension or solution, and may include liquids containing chemicals in solution.

SEWAGE DISPOSAL SYSTEM.—A system for the disposal of domestic sewage by means of a septic tank, cesspool, or mechanical treatment, all designed for use apart from a public sewer to serve a single establishment, building, or development.

SEWAGE EJECTOR.—A mechanical device used to pump or eject sewage.

SEWAGE EJECTOR PIT.—A tank or pit that receives sewage located below the normal grade of the gravity system and that must be emptied by mechanical means.

SIDE VENT.—A vent connecting to the drain pipe through a fitting at an angle not greater than 45 degrees to the vertical.

SLOPE.—See grade.

SOIL PIPE.—A pipe that conveys sewage containing fecal matter.

SPECIAL WASTE.—Waste which requires special treatment before entry into the normal plumbing system.

STACK.—A general term for any vertical line of soil, waste, vent, or inside leader piping. This does not include vertical fixture and vent branches that do not extend through the roof or that pass through not more than two stories before being reconnected to the vent stack or stack vent.

STACK VENT (SOMETIMES CALLED A

WASTE VENT OR SOIL VENT).—The extension of a soil or waste stack above the highest horizontal drain connected to the stack.

STACK VENTING.—A method of venting a fixture or fixtures through the soil waste stack.

STORM DRAIN.—See building storm drain.

STORM SEWER.—A sewer used for conveying rain water, surface water, condensate, cooling water, or similar clear liquid wastes.

SUB-HOUSE DRAIN.—See building sub-house drain.

SUB-SURFACE DISPOSAL FIELD.—A system of open jointed tile or perforated pipes or drains through which storm water or the sewage effluent from a septic tank is distributed beneath the surface of the ground for absorption into the soil, as well as evaporation into the air during favorable weather conditions.

SUB-SOIL DRAIN.—A drain that receives only sub-surface or seepage water and conveys it to a place of disposal.

SUMP PIT.—A tank or pit that receives clear liquid wastes, that do not contain organic materials or compounds subject to decomposition, located below the normal grade of the gravity system and which must be emptied by mechanical means.

SUMP PUMP.—A mechanical device used to eject or pump the liquid waste from a sump pit into the gravity drainage system.

SUPPORTS.—Devices for supporting and securing pipe, fixtures, and equipment.

SWIMMING POOL.—Any structure, basin, chamber or tank containing water for swimming, diving, or recreational bathing and having a depth of 2 ft. or more at any one point.

TRAP.—A fitting or device with a smooth interior passage, the inside diameter of which is equal to the inlet pipe diameter, and which provides a liquid seal of at least 2 in.

TRAP SEAL.—The maximum vertical depth of liquid that a trap will retain, measured between the crown weir and the top of the dip of the trap. Seal 2 in. in normal traps and 3 in. or more for deep seal traps.

VACUUM BREAKER.—A device used to prevent backflow by siphonic action.

VENT PIPE.—See vent system.

VENT STACK.—A vertical vent pipe installed primarily for the purpose of providing circulation of air to and from any part of the drainage system.

VENT SYSTEM.—A pipe or pipes installed to provide a flow or air to or from a drainage system or to provide a circulation of air within such system to protect trap seals from siphonage and back pressure.

VERTICAL PIPE.—Any pipe or fitting that is installed in a vertical position or that makes an angle of not more than 45 degrees with the vertical.

WASTE PIPE.—A pipe that conveys only

Reference Standard 16

liquid waste, free of fecal matter.

WATER-DISTRIBUTION PIPING.—In a building or premises, piping that conveys water from the water service pipe to the plumbing fixtures and other water outlets.

WATER (STREET) MAIN.—A water-supply pipe for public or community use controlled by public authority.

WATER OUTLET.—As used in connection with the water-distributing system, is the discharge opening for the water to a fixture; to atmospheric pressure (except into an open tank which is part of the water-supply system); to a boiler or heating system; to any water-operated device or equipment requiring water to operate, but not a part of the plumbing system.

WATER SERVICE PIPING.—That portion of the water supply system extending from the public street water main to the house control valve inside the building to a point where the supply is fully metered.

WATER SUPPLY SYSTEM.—Consists of the water-service pipe, the water-distribution pipes, and the necessary connecting pipes, fittings, control valves, and all appurtenances used for conveying water.

YOKE VENT.—A pipe connecting upward from a soil or waste stack to a vent stack for the purpose of preventing pressure changes in the stack.

Section P101.0 General Provisions

P101.1 Protection of Pipes.-

(a) **Breakage.**—Pipe passing under or through walls shall be protected from breakage. Any plumbing pipe passing under a footing or through a foundation wall shall be protected from carrying any weight of the structure by an arch or lintel constructed above the pipe by an iron-pipe sleeve built into the masonry wall and greater in size than the pipe passing through the wall, or by an equivalent method of protection.

(b) **Corrosion.**—Pipe subject to external corrosion by passing through or under corrosive material shall be protected against external corrosion by protective coating, wrapping, or other equivalent means that will resist such corrosion.

P101.2 Trenching, Excavation, and Backfill.-

(a) **Material for backfill.**—Trenches shall be backfilled by hand and tamped, in 6 in. layers, for 1 ft. above the crown of the pipe. Loose earth, free from frozen earth chunks or other material that may break the pipe, shall be used to provide firm bedding around the pipe.

(b) Trenching methods.-

(1) Trenches shall be excavated to a width sufficient to permit workmen to properly install the pipe. The bottom of the pipe trench shall be constructed so that the pipe between joints will have solid bearing along its entire length. Bell holes shall be provided at points where the

pipe is joined together to insure uniform bearing along the length of the pipe. In rock excavation the material shall be removed 3 in. to 6 in. below the grade line of the trench and then backfilled and tamped to grade with sand to provide a uniform firm foundation for the pipe. If soil materials of class 11-65 or poorer are encountered the pipe shall be supported in accordance with the applicable provisions of the building code for structural work.

(2) Where open trenches are impractical, pipe may be installed by driving or tunneling methods acceptable to the commissioner. Where driving or tunneling methods are employed, special care shall be exercised to protect the pipe from breakage and against earth settling or caving. Pipe may be installed in a previously driven conduit slightly larger than the pipe. Earth tunnels with a length not exceeding the depth of the trench may be employed, providing adequate supporting structures are provided to prevent future settling or caving.

(3) Permits for sidewalk and street openings shall be obtained from the department of highways.

P101.3 Sleeves.-

(a) The annular space between sleeves and pipe through foundation or exterior building walls shall be filled or partly caulked with polysulphide compound, lead, or other equivalent waterproofing material.

(b) Where pipes and sleeves pass through construction required to have a fire-resistance rating, they shall comply with the applicable requirements of the building code.

P101.4 Ratproofing.—In an apartment or in dwelling units, and in buildings or building areas used for the storage or preparation of food, the openings in walls, floors, or ceilings for the passage of pipes shall be closed and protected by metal collars securely fastened to the structure.

P101.5 Toilet Facilities for Workmen.—The site upon which any building, except a one- or two-family dwelling, is being constructed shall be provided with toilet facilities for use of workmen as specified in Table RS 16-5.

Section P102.0 Materials

P102.1 General Requirements.-

(a) **Materials required.**—All materials used in the construction of any plumbing system, fixtures, or equipment shall be as required by this reference standard.

(b) **Installation.**—All materials installed in plumbing systems shall be handled and installed so as to avoid damage to the material.

P102.2 Standards for Plumbing Materials.-

(a) **Materials.**—Materials shall conform to one of the standards cited in Table RS 16-1. Equivalent materials not listed in Table RS 16-1 may be used provided they are approved.

Reference Standard 16

*TABLE RS 16-1 STANDARDS FOR PLUMBING MATERIALS^a

| Materials | ANSI | Other |
|---|--------------------------|---|
| Ferrous Pipe and Fittings- | | |
| Cast iron soil pipe and fittings coupling... | None | CISPI 310-1985 |
| Hubless cast iron soil pipe | None | CISPI 301-1985 |
| Cast iron soil pipe and fittings, extra heavy and service weights | None | CS188-66 |
| Cast iron water pipe | A21.6-1962 A21.8-1962 | |
| Cast iron pipe, drainage, vent and waste... | None | FS-WW-P356-1936 |
| Cast iron pipe, pressure (50 lb.) gas and water | None | FS-WW-P360a-1959 |
| Cast iron (threaded) pipe | A40.5-1943 | |
| Cast iron (threaded) fittings | B16.4-1963 | |
| Cast iron drainage fittings | B16.12-1965 | |
| Galvanized pipe and fitting | None | FS-WW-P406(1) 1945 |
| Malleable iron fittings (threaded) 150 lbs. | B16.3-1963 | |
| 300 lbs. | B16.3-1963 | |
| Steel pipe, seamless and welded, black and zinc coated (not intended for close coiling) | B36.20-1966 | |
| Steel pipe, seamless and welded, black and zinc coated (suitable for close coiling) | B36.1-1966 | |
| Stainless steel pipe | B36.19-1965 | |
| Union, malleable iron or steel | None | *FS-WW-O531a-1957 FS-WW-U536(1)-1953 |
| Wrought-iron pipe | B36.2-1966 | |
| Valves, cast iron, gate 125 and 250 lb. threaded and flanged | None | FS-WW-V58(1)-1946 |
| Pipe fittings, bronze and ferrous (bushings, plugs and locknuts), threaded | None | FS-WW-P471(1)-1946 |
| Nipples, pipe threaded | None | FS-WW-N351a-1956 |
| Non-Ferrous Pipe and Fittings- | | |
| Finished and rough brass plumbing fixture fittings | None | ASME A112.18.1M-79 |
| Brass tube | H36.1-1967 | |
| Brass pipe | H27.1-1963 | |
| Brass or bronze flanges and flanged fittings, 150 and 300 lb. | B16.24-1962 | |
| Brass or bronze screwed fittings, 125 lb and 250 lb. | B16.15-1964 | |
| Cast-bronze solder joint pressure fittings | B16.18-1963 | |
| Cast-brass solder joint drainage fittings | B16.23-1960 | |
| Copper pipe | H26.1-1963 | |
| Copper pipe, threadless | H26.2-1963 | |
| Seamless copper tube | H23.3-1965 | |
| Copper water tube, type K, L | H23.1-1967 | |
| Wrought copper and wrought bronze solder joint fittings | H16.22-1963 | |

^aAs enacted but "FS-WW-U531a-1957" probably intended.

Reference Standard 16

| | | |
|---|---------------|---------------------|
| Wrought copper and wrought copper alloy solder joint drainage fittings..... | H16.29-1966 | |
| Lead pipe and traps | None | WW-P325-1944 |
| Unions, brass or bronze, 250 lb. | None | FS-WW-U516-1933 |
| Valves, bronze; angle, check and globe, 125 and 150 lb., threaded and flanged | None | FS-WW-V51a(2)-1954 |
| Valves; bronze, gate, 125 and 150 lb., threaded and flanged | None | FS-WW-V54b-1962 |
| Pipe fittings, bronze and ferrous (bushings, plugs and locknuts), threaded | None | FS-WW-P471(1)-1946 |
| Non-Metallic Pipe and Fittings- | | |
| Asbestos cement (sewer) pipe ^b | None | ASTM-C428-65T |
| Asbestos cement underdrain | None | ASTM-C508-67T |
| Clay drain tile | None | ASTM-C4-62 |
| Concrete sewer pipe, reinforced | None | ASTM-C76-65T |
| Concrete sewer pipe, nonreinforced.... | None | ASTM-C14-67 |
| Clay sewer pipe, standard strength | A106.3-1965 | ASTM-C13-64T |
| Vitrified clay sewer pipe, salt-glazed and unglazed extra strength..... | None | ASTM-C200-65T |
| Vitrified clay sewer pipe, ceramic glazed, extra strength | None | FS-SSP361b-1962 |
| Vitrified clay sewer pipe, perforated, standard strength | A106.1-1962 | |
| Plumbing Fixtures- | | |
| Drinking fountains | Z4.2-1942 | |
| Enameled cast iron plumbing fixtures.. | None | ASME 112.19.1M-87 |
| Earthenware (vitreous glazed) plumbing fixtures | None | CS111-43 |
| Formed steel enameled sanitary ware.. | None | FS-WW-P541b(2)-1962 |
| Formed metal porcelain enameled sanitary ware | None | FS-WW-P541b(2)-1962 |
| Heaters, water, instantaneous (steam-water converter type) | None | FS-WW-H191-1954 |
| Plumbing fixtures (for) land use | None | FS-WW-P541b(2)-1962 |
| Stainless steel plumbing fixtures | None | ASME A112.19.3M-87 |
| Vitreous china plumbing fixtures | A112.19.2M-82 | |
| Stills, water; portable (without heating device) for U.S.P." distilled water".... | None | FS-RR-S726(1)-1950 |
| Porcelain enameled formed steel plumbing fixtures. | None | ASME A112.19.4M-84 |
| Miscellaneous Materials and Standards- | | |
| Automatic relief valves | Z21.22-1964 | |
| Air gap standards | A40.4-1942 | |
| Backflow preventers | A40.6-1943 | |
| Brass cleanout plugs | None | *FS-WW-P401(3)-1951 |
| Brazing filler metal | None | ASTM-B260-62T |
| Caulking lead, Type I | None | FS-QQ-L156(1)-1946 |
| Caulking: lead wool and lead pig | None | FS-QQ-C40-1963 |
| Cement lining | A21.4-1964 | |
| Coal-tar, enamel, protective coating.... | None | AWWA-C203-62 |

*As enacted but not applicable for this item.

Reference Standard 16

| | | |
|--|---------------|-----------------------------|
| Fixture setting compound | None | FS-HH-C536a-1954 |
| Flange dimensions, standard classes 125 and 250 cast iron flanges, classes 150, 250 and 300 bronze flanges (land use) | None | FS-WW-F406a(1)-1943 |
| Galvanized iron and steel sheets | G8.2-1964 | |
| Gaskets, plumbing-fixture-setting | None | FS-HH-G116-1936 |
| Hangers and supports, pipe | None | FS-WW-H171b-1959 |
| Resilient joints | None | ASTM-C425-64 |
| Rubber gaskets (concrete sewer pipes). | None | ASTM-C443-65 |
| Seal joints, sewer | None | FS-SS-S169-1954 |
| Sheet brass, leaded and non-leaded | None | ASTM-B36-66 ASTM-B121-66 |
| Sheet copper | None | ASTM-B152-60 |
| Sheet lead, grade A | None | FS-QQ-L201d-1961 |
| Solder metal | None | ASTM-B32-66T |
| Steel septic tanks | None | CS177-62 |
| Domestic hot water heaters | Z21.10.1-1966 | C72.1-1949 |

Notes-

**^a Abbreviations used in the table refer to the following organizations:

*** USASI—United States of America Standards Institute

ASTM—American Society for Testing and Materials

AWWA—American Water Works Association

CS—Commercial Standards

FS—Federal Specifications

**Local Law 100-1989; Local Law 29-1989; Local Law 63-1976*

***List as enacted, but probably intended to add "ASME-American Society of Mechanical Engineers."*

****As enacted, but probably intended to read "ANSI-American National Standards Institute, Inc."*

^b Asbestos cement building sewer pipe shall meet the requirements of ASTM Standard C428-63T expanded as follows:

- (1) Additional sizes 4 in. and 5 in.
- (2) No hydrostatic test for building sewer service
- (3) Flexural strength:

| Size (in.) | Length (in.) | Class 1500 | Class 2400 | Class 3300 |
|------------|--------------|------------|------------|------------|
| 4 | 10 | 550 | 775 | 1100 |
| 4 | 13 | 750 | 1000 | 1350 |
| 5 | 10 | 950 | 1375 | 1900 |
| 5 | 13 | 1250 | 1775 | 2350 |
| 6 | 10 | 1500 | 1700 | 2100 |
| 6 | 13 | 2000 | 2200 | 2600 |

(4) Crushing strength: Include 4 in. and 5 in. for Classes 1500, 2400, 3300
Crushing test: One specimen from each 300 lengths of 4 in., 5 in., and 6 in. size pipes.

Reference Standard 16

†(b) **Plastic piping and fittings.**-Plastic piping and fittings may be used only in residential buildings of three stories or less in height, except that corrugated polyethylene piping with a diameter of twelve inches or more and plastic fittings may be used in connection with any type of building for underground yard drainage and storm water piping when used outside of the foundation walls of the building and not connecting to any piping system from the interior of the building and shall be approved. Plastic drain, waste and vent pipe and fittings used inside of residential buildings of three stories or less in height shall be required to conform with ASTM Standard D2661-97 Specification for Acrylonitrile-Butadiene-Styrene (ABS) Schedule 40 Plastic Drain, Waste, and Vent Pipe and Fittings or ASTM Standard D2665-98 Specification for Poly Vinyl Chloride (PVC) Plastic Drain, Waste, and Vent Pipe and Fittings, as well as the International Association of Plumbing and Mechanical Officials Installation Standards for ABS Building Drain, Waste and Vent Pipe and Fittings (IAPMO IS 5-92) and PVC Building Drain, Waste and Vent Pipe and Fittings (IAPMO IS 9-95) and Non-Metallic Building Sewers (IAPMO IS 1-91).

†*Local Law 2-2001; Local Law 58-1973; Local Law 75-1971*

P102.3 Identification of Materials.-Materials shall be identified as provided herein.

P102.4 Piping System Materials.-

(a) Water supply systems.-

*(1) **WATER SERVICE PIPE.**-Water service piping within the property line shall be of red brass or copper pipe; type K copper tube; type "TP" threadless copper; cast iron or ductile iron water pipe; or plastic pipe in accordance with section P102.2(b). Water service piping outside of the property line shall comply with requirements of the department of environmental protection. When used underground in corrosive soil or fill, all ferrous pipe and fittings shall be coal tar, enamel coated. Threaded joints shall be coated and wrapped after installation regardless of the nature of the soil.

(2) **WATER DISTRIBUTION SYSTEM PIPE.**-Water distribution system piping shall be of red brass pipe, type "TP" threadless copper pipe, hard temper type "K" copper tube, hard temper type "L" copper tube, galvanized wrought iron pipe, galvanized steel pipe, or ductile cast iron properly anchored. Cast iron and ductile-iron pipe may be cement lined in accordance with ANSI A21.4-1971. Type "L" copper tube shall not be installed in soil or concrete floor fill.

***** (b) Drainage systems.**-

**Local Law 29-1987; Local Law 63-1976; Local Law 58-1973*

****Local Law 63-1976*

(1) **ABOVE GROUND PIPING WITHIN BUILDINGS.**-Soil, waste, and storm water or leader piping above ground in buildings shall be brass pipe, copper pipe,

hard temper type "K" copper tube, hard temper type "L" copper tube, extra heavy cast iron soil pipe, service weight cast iron soil pipe, no-hub cast iron soil pipe, AWWA class 22 or stronger iron, stainless steel pipe, threaded cast iron pipe, galvanized wrought iron pipe, galvanized steel pipe, or lead pipe, singly or in combination. Cast iron piping and fittings may be coated or uncoated. The maximum developed length to which lead may be used in connection with any one fixture shall be 5 feet. Plastic pipe will be permitted if it conforms to the requirements set forth in section P102.2(b).

(2) **UNDERGROUND PIPING WITHIN BUILDINGS.**-

All underground building drains shall be extra heavy cast iron soil pipe, service weight cast iron soil pipe, no-hub cast iron soil pipe, AWWA Class 22 or stronger cast iron water piping, ductile cast iron, brass pipe, type "K" hard temper copper tube, or plastic pipe conforming to the requirements set forth in section P102.2(b). Cast iron pipe and fittings may be coated or uncoated.

(3) **BUILDING HOUSE SEWERS.**-

** a. Building house sewers shall be extra heavy iron soil pipe and fittings, service weight cast iron soil pipe and fittings, no-hub cast iron soil pipe and fittings, AWWA class 22 or stronger cast iron water piping, ductile cast iron and fittings, or plastic pipe conforming to the requirements set forth in section P102.2(b), a minimum of 8 in. size in the borough of Manhattan and 6 in. in the other boroughs, except that a house sewer from one- and two-family dwellings may be the size specified in Table RS 16-13 and may run up to the street line. Cast iron pipe and fittings may be coated or uncoated.

***Local Law 58-1973; Local Law 39-1972*

b. Building house sewers for one- and two-family dwellings when installed in a separate trench from the water service may be of vitreous pipe or asbestos cement pipe.

c. Existing building sewers may be used in connection with a new building sewer and drainage system only when found by examination and test to conform to the new system in quality of material.

†(4) **UNDERGROUND YARD DRAINAGE AND STORM WATER PIPING.**-Underground yard drainage and storm water piping within the property line but outside of the foundation walls of the building shall be extra heavy cast iron soil pipe, AWWA Class 22 or stronger cast iron water pipe, ductile cast iron, service weight cast iron, no-hub cast iron soil pipe, asbestos cement pipe, vitreous tile pipe, concrete pipe, or plastic pipe conforming to the requirements set forth in section P102.2(b). Cast iron pipe and fittings may be coated or uncoated.

†*Local Law 63-1976; Local Law 58-1973*

(5) **CHEMICAL WASTES (ACID WASTES)**-

Separate drainage systems for chemical waste shall be of acid resistant material when the waste water at any point in the system will have a pH value of less than 4.5

Reference Standard 16

or more than 9.5. Chemical waste drainage piping shall be low expansion, borosilicate glass pipe; high silicon cast iron pipe; chemical stoneware pipe; chemical lead pipe; or approved plastic pipe regardless of building height, or other equivalent materials. Materials may be used singly or in combination.

***** (c) Venting Systems.-**

(1) ABOVE GROUND VENTING.-Vent piping installed above ground shall be brass pipe, type "TP" threadless copper pipe, hard temper type "K" copper tube, hard temper type "L" copper tube; extra heavy cast iron soil pipe, service weight cast iron soil pipe, no-hub cast iron soil pipe, AWWA Class 22 or stronger cast iron water pipe, ductile cast iron, threaded cast iron pipe, galvanized wrought iron pipe, galvanized steel pipe, singly or in combination. Cast iron pipe and fittings may be coated or uncoated. Plastic pipe will be permitted if it conforms to the requirements set forth in section P102.2(b).

****Local Law 63-1976*

(2) UNDERGROUND VENTING. Underground vent piping shall be extra heavy cast iron soil pipe, service weight cast iron soil pipe, no-hub cast iron soil pipe, AWWA Class 22 or stronger cast iron water pipe, ductile cast iron, brass pipe, copper pipe, or type "K" hard temper copper tube. Cast iron pipe and fittings may be coated or uncoated.

(3) CHEMICAL WASTE SYSTEMS.-Vent piping for chemical waste systems shall conform to the requirements for the chemical waste pipe.

(d) Fittings.-The materials of which water supply, drainage, and venting system pipe fittings are made shall conform to the type of piping material used in the water supply, drainage, or venting system (i.e., brass or bronze fittings with copper pipe or tubing), except that black cast iron may be used with brass or galvanized pipe. Threaded drainage pipe fittings shall be of the recessed drainage type. Fittings used to prevent or

reduce galvanic corrosion may be installed within a system only at the point of isolation.

(e) Other piping systems and miscellaneous materials.-

(1) ROOF DRAINS.-Roof drains shall be cast iron, bronze, copper, brass, stainless steel, lead, or other equivalent corrosion resistant material.

(2) EXTERIOR LEADERS (DOWNSPOUTS).-

Exterior leaders and gutters installed above ground level shall be sheet metal or copper, aluminum, galvanized steel, stainless steel, or other equivalent corrosion resistant material. Pipe (galvanized steel, galvanized wrought iron, cast iron or brass) may be used for the first 15 ft. of leader extending up from grade, providing that the pipe is securely anchored with offset clamps to the face of building at two points in the vertical section of pipe. Pipe will not be acceptable above 15 ft.

*(3) SUBSOIL DRAINS.-Subsoil drains shall be clay tile that is open jointed, horizontally split, or perforated; open jointed cast iron soil pipe; porous concrete pipe; asbestos cement pipe that is open jointed, horizontally split, or perforated or plastic pipe in accordance with section P102.2(b) that is open jointed, horizontally split, or perforated.

**Local Law 39-1972; Local Law 58-1973*

(4) LEAD BENDS AND TRAPS.-The walls of lead bends and traps shall be at least 1/8 in. thick.

(5) SHEET COPPER.-Sheet copper shall weigh at least 12 ounces per sq. ft.

(6) SHEET LEAD.-Sheet lead shall weigh at least 4 psf.

(7) CAULKING FERRULES.-Caulking ferrules shall be brass or copper, and shall be made in accordance with Table RS 16-3.

Ferrules may be tapped "T" or tapped "Y" types with bossings provided on the tapped connection.

(8) SOLDERING BUSHINGS.-Soldering bushings shall be brass or copper in accordance with Table RS 16-4.

TABLE RS 16-3 CAULKING FERRULES

| Pipe Sizes (In.) | Inside Diameter of Ferrule (In.) | Minimum Length of Ferrule (In.) | Minimum Weight of Each Ferrule |
|------------------|----------------------------------|---------------------------------|--------------------------------|
| 2 | 2 1/4 | 4 1/2 | 1 lb. - 0 oz. |
| 3 | 3 1/4 | 4 1/2 | 1 lb. - 12 oz. |
| 4 | 4 1/4 | 4 1/2 | 2 lbs. - 8 oz. |

TABLE RS 16-4 SOLDERING BUSHINGS

| Pipe Sizes (In.) | Minimum Weight of Each Ferrule |
|------------------|--------------------------------|
| 1 1/4 | 6 oz. |
| 1 1/2 | 8 oz. |
| 2 | 14 oz. |
| 2 1/2 | 1 lb. - 6oz. |
| | 2 lbs-. 0 oz. |
| 4 | 3 lbs-. 8 oz. |

Reference Standard 16

(9) FLOOR FLANGES.-Floor flanges for water closets or similar fixtures shall be of cast brass at least 1/8 in. thick, of cast iron at least 1/4 in. thick and having a caulking depth not less than 2 in., or of hard lead weighing at least 1 lb.-9 oz. and composed of lead alloy having at least 7.75 per cent antimony by weight. The use of floor flanges of other equivalent materials may be used.

(10) CLEANOUT PLUGS.-Cleanout plugs shall be of brass at least 1/8 in. thick and shall have raised square or hexagonal heads except that where raised heads will cause a tripping hazard, countersunk heads shall be used. Cleanout plugs of nylon may be used in exposed or accessible locations.

(11) FLUSH PIPES AND FITTINGS.-Flush pipes and fittings shall be of nonferrous material. When brass or copper tubing is used, the material shall be at least 0.0313 in. thick (no. 22 U.S. gage).

(12) TUBULAR BRASS TRAPS.-The "J" bend and wall tube shall be formed of brass tubing having a wall thickness of at least 0.045 in. (no.17 P & S gage) conforming to ASTM-B135-63, alloy No. 3. Bends shall be properly annealed after forming to prevent season-cracking. Nuts shall be cast brass conforming to ASTM-B146-52, alloy 6A, and the collars shall be cut from brass tubing conforming to ASTM B135-63, alloy No. 4. Collars shall be fully soldered on "J" bends.

*** (13) INSULATION.-Coverings and insulations, including vapor barriers, shall have a maximum flame spread rating of 25 without evidence of continued progressive combustion, and shall have a maximum smoke developed rating of 50. If the coverings and insulations, including vapor barriers are to be applied with adhesives, they shall be tested as applied with such adhesives, or the adhesives used shall have a maximum flame spread rating of 25 and a maximum smoke developed rating of 50. Tests shall be performed in accordance with ASTM-E84-61.

***Local Law 63-1976

(14) MISCELLANEOUS.-Internal and external parts of faucets, valves, ballcocks, etc. may be made with plastics meeting the criteria of this reference standard.

Section P103.0 Joints and Connections

*P103.1 Types of Joints for Piping Materials.-

*Local Law 13-1993

(a) **Asbestos cement pipe joints.**-Joints in asbestos cement pipe shall be made with sleeve couplings of the same composition as the pipe, and sealed with approved rings.

(b) **Brazed joints.**-Brazed joints for type "TP" threadless copper, copper, brass pipe, or copper water tube type "K" or "L" shall be made by first cleaning down to the base metal the surfaces to be welded or brazed, then applying a flux for such joints, and finally, making the joint with a brazing alloy having a melting point higher than 1000°F.

*** (c) **Cast iron pipe.**-Joints in cast iron pipe shall be compressed elastomeric, mechanical, caulked, or threaded,

or of another type as approved.

***Local Law 63-1976

*** (d) **Cast iron soil pipe.-**

(1) Caulked joints for cast iron bell and spigot soil pipe shall be firmly packed with oakum or hemp, filled with molten lead at least 1 inch deep and the surface shall not be depressed more than 1/8 inch below the rim of the hub. No paint, varnish, or other coatings will be permitted on the jointing material until after the joint has been tested and accepted. Lead shall be run in one pouring and shall be caulked tight.

(2) Mechanical joints for cast iron soil pipe shall be made with an approved preformed molded ring secured by pulling the pipe together in such a way as to compress the molded ring or shall be made with a corrosion resistant joint and clamp assembly surrounding a sealing sleeve of an approved elastomeric material so that the sealing sleeve is firmly compressed by the tightening device in the clamp assembly to provide a gas and water tight joint. Obstructions to the flow of water through a mechanical joint shall not be greater than those of a caulked joint.

***Local Law 63-1976

(e) **Cast iron water pipe (caulked joint).**-Caulked joints for cast iron bell and spigot water pipe shall be firmly packed with clean and sound asbestos rope, treated paper rope, or with molded or tubular approved rings. The remaining space in the hub shall be filled with molten lead according to the following schedule:

| Pipe Size | Depth of Lead |
|--------------------|---------------|
| Up to 20 in. | 2 ¼ in. |
| 24, 30, or 36 in. | 2 ½ in. |
| Larger than 36 in. | 3 in. |

Lead shall be run in one pouring and shall be caulked tight.

*** (f) **Cast iron water pipe.**-Compression and mechanical joint.-

Mechanical joints in cast iron water pipe shall conform to ANSI A21.11-1972 and shall be made with a flanged collar, a ring gasket and appropriate number of securing bolts, or with a preformed molded ring secured by pulling the pipe together in such a way as to compress the molded ring. Mechanical joints may be used wherever AWWA cast iron or ductile iron is permitted in section P102.0.

***Local Law 63-1976

(g) **Clay sewer pipe.**-Joints in clay sewer pipe shall either be of hot poured compounds, or of preformed materials consisting of approved resilient materials that are installed on both the spigot and bell ends.

(h) **Concrete sewer pipe.**-Joints in concrete sewer pipe shall be of hot poured compound, of preformed material, or of approved gasketing rings.

(i) **Concrete pipe (slip joint).**-Flexible joints between lengths of concrete pipe may be made by using approved

Reference Standard 16

rubber materials on the spigot end and in the bell end of the pipe.

(j) Copper tube (type "K" or "L").—Joints in type "K" or "L" hard temper copper tube for water supply piping or drainage and vent piping shall be made by soldering or brazing. Solder shall be lead-free. Permissible lead-free solders are 95-5 tin-antimony, 96-4 tin-silver, 94-6 tin-silver, 95-5 tin-silver, or any other solder approved by the commissioner. Joints in copper tube for vent or drainage piping shall be made using cast brass or wrought copper solder joint drainage fittings. Tubing for water piping may be bent by mechanical means with no crushing or crimping of the tubing. For purposes of this section, lead-free solder shall mean solder containing less than 0.2 percent lead.

***Local Law 13-1993; Local Law 29-1987; Local Law 63-1976*

(k) Couplings.—All built-in threaded piping carrying gas or water shall be installed with couplings.

(l) Expansion joints.—Expansion joints must be accessible and shall be used only where necessary to provide for expansion and contraction of the pipes. All expansion joints shall be of type and material suitable for use with the type of piping in which they are installed.

(m) Hot poured joints.—All surfaces of the joint shall be cleaned and dried before pouring. Hot poured compound for clay or concrete sewer pipe shall not be water absorbent, and when poured against a dry surface, shall have a bond to withstand a pressure of at least 100 psi. If wet surfaces are unavoidable, a suitable primer shall be applied. The compound shall not soften sufficiently to destroy the effectiveness of the joint when subjected to a temperature of 160° F., nor shall it be soluble in any of the waste carried by the drainage system. Approximately 25 percent of the joint space at the base of the socket shall be filled with jute or hemp. A pouring collar, rope, or other device shall be used to hold the hot compound during pouring. Each joint shall be poured in one operation until the joint is filled. Joints shall not be tested until at least 1 hr. after pouring.

(n) Glass pipe joints.—Joints in chemical waste glass piping shall be made with approved compression coupling, adapter coupling or adjustable joints.

(o) Preformed joints.—Preformed collars shall be formed in both the spigot and bell of the pipe in advance of closing the joint. Collar surfaces shall be conical with side slopes of 3 degrees with respect to the axis of the pipe, and the length shall be equal to the depth of the bell socket. Prior to making joint contact, surfaces of collars shall be cleaned and coated with solvents and adhesives. When the spigot end is inserted in the collar of the bell end, it shall bind before reaching the base of the socket. Collar material shall be inert and resistant to both acids and alkalies.

(p) Slip joints.—Slip joints in expansion joints will be permitted. Slip joints shall be made with packing or gasket material or with ground joint brass compression rings. Ground joint brass connections that allow adjustment of tubing but provide a rigid joint when made up shall not be

considered as slip joints. Slip joints will be permitted between the stop valve and faucet connection but the stop and pipe size shall not be less than required pipe size indicated for the fixture by Table RS 16-7, but not less than 3/8 inch size nor longer than 18 inches from stop to faucet. Slip joints will be permitted between a tubular fixture trap and the sanitary waste.

****Local Law 63-1976*

(q) Soldered joints.—Soldered joints for type "K" or type "L" tube shall be made with fittings. Soldered joints shall be lead-free, as defined in subdivision (j).

***Local Law 13-1993; Local Law 29-1987; Local Law 63-1976*

(r) Threaded joints.—Threaded joints shall conform to American national taper thread, USASI-B2.1-1960 or FS-GGG-P351a. All burrs shall be removed. Pipe joint cement and paint shall be used only on male threads.

(s) Threadless copper pipe.—Joints in threadless copper pipe for water supply piping shall be made by brazing.

(t) Unions.—Unions shall have metal-to-metal ground seats, and their material shall conform to the type of piping in which they are installed.

(u) Wiped joints.—Joints in lead pipe or fittings, or between lead pipe or fittings and brass or copper pipe, ferrules, solder nipples, or traps, shall be full wiped joints. A wiped joint shall have an exposed surface of at least 3/4 in. on each side of the joint and a minimum thickness of 3/8 in. at its thickest part.

P103.2 Joints Between Different Piping Material-

(a) Cast iron and copper tube.—Joints between cast iron and copper tube shall be made either by directly caulking the copper tube in to the bell of the cast iron pipe or by using a brass caulking ferrule and properly sweating the copper tube to the ferrule.

(b) Cast iron and vitrified clay.—Joints between cast iron pipe and vitrified clay pipe shall be made either of hot poured bitumastic compound or by a preformed bituminous ring. This ring shall after ramming, completely fill the annular space between the cast iron spigot and the vitrified clay hub.

(c) Copper tube and threaded pipe.—Joints between copper tube and threaded pipe shall be made with brass adapter fittings. The connection between the copper tube and the fitting shall be properly brazed or soldered, and the connection between the threaded pipe and the fitting shall be made with a standard pipe size screw joint.

****Local Law 63-1976*

(d) Threaded pipe and cast iron pipe.—Joints between threaded pipe and cast iron pipe shall be either caulked or threaded, or shall be made with adapted fittings. Threaded piping shall include wrought iron, steel, brass, or copper pipe.

(e) Lead and cast iron, wrought iron, steel, copper or brass pipe.—Joints between lead and cast iron, wrought iron, steel, and copper or brass pipe shall be made by means of wiped joints to a caulking ferrule, soldering nipple, or bushing, or by means of a soil pipe adapter soldered to the copper tube.

(f) Asbestos-cement pipe to metal.—Joints between

Reference Standard 16

asbestos-cement pipe and metal shall be made by means of an adapter coupling which shall be installed as required for cast iron soil pipe.

P103.3 Connections Between Drainage Piping and Certain Fixtures.-Connections between drainage pipe and water closets, floor outlet service sinks, pedestal urinals, earthenware trap standards, or any other fixture with floor outlets, shall be made by means of brass, cast iron or other flanges that are caulked, soldered, or screwed to the drainage pipe. The connection shall be bolted, with a gasket or washer set between the earthenware and the connection. The gasket or washer shall not absorb moisture, break down, or lose its shape when immersed in 160°F water for 5 minutes. The floor flange shall be set on a waterproof, firm base with no rough edges at the hole for drain connection.

P103.4 Tightness.-Joints and connections in the plumbing system shall be made gastight and watertight for the pressure prescribed in the applicable test requirements, with the exceptions of those portions of perforated or open joint piping that are installed underground for the purpose of collecting and conveying ground or seepage water to the storm drains.

P103.5 Waterproofing.-Joints between piping and roof shall be made watertight by the use of lead, copper, aluminum, or other equivalent flashings or flashings material. Exterior wall openings shall be made watertight.

P103.6 Other joints.-Equivalent methods and materials for making pipe joints may be used if approved.

Section P104.0 Plumbing Fixtures

P104.1 Requirements.-

(a) Minimum number of fixtures.-The number of plumbing fixtures required for an occupancy shall be as listed in Table RS 16-5. The requirements for an occupancy not listed in the table shall be subject to approval by the Commissioner.

(b) Facilities for each sex.-Where public toilet or bathing facilities are designed for use by more than one person at a time, separate facilities shall be installed for each sex.

**** (c)** In every building where public toilet facilities are provided, there shall be at least one water closet stall for each sex which is accessible to the physically handicapped, at least 3 ft. wide by 5 ft.-6 in. in depth, having a door (if used) that is 32 in. wide and swings out to accommodate a wheelchair. The water closet set*** shall be set 17 to 19 in. above the floor. The stall shall be provided with grab bars on each side, the grab bars shall have an outside diameter of 1 1/2 in., and shall be 33 to 36 in. above and parallel to the floor, with 1 1/2 in. clearance from the wall. One drinking fountain facility, not of the recessed type, shall be provided. The provisions of reference standard RS 4-6 shall supplement the foregoing requirements.

(d) Accessibility.-The fixtures specified in Table RS 16-5 for public buildings shall be located not more than one floor above nor more than one floor below the floor occupied by the people for whose use the fixtures are intended, unless elevator service is available except that in buildings classified in occupancy group E which are accessible to the physically handicapped, there shall be at least one such toilet stall for male and one for female for every 300 occupants of each sex in the building.

****Local Law 58-1987**

*****As enacted, but "seat" probably intended.**

†P104.2 Installation of Fixtures.-

(a) No person shall install any plumbing fixture unless:
(1) such fixture meets the water saving performance standards and product labeling requirements provided in paragraphs b and c of this subdivision; and

(2) such fixture meets the standards as provided for in table 16-1; and

(3) i. the manufacturer has furnished to the commissioner, in such form as the commissioner shall determine, the identification and performance specifications of such fixture, and a certification that such fixture meets the standards as provided for in this section, and the commissioner has included such fixture on the list published pursuant to paragraph d of this subdivision or

ii. such fixture is included on the "list of certified water saving plumbing fixtures" published pursuant to section 15-0314 of the environmental conservation law; however this option shall not apply to water closets and associated flush valves on and after January first, nineteen hundred ninety-two which shall be certified to the commissioner pursuant to item i. of this subparagraph three.

(b) The water-saving performance standards for sink and lavatory faucets, shower heads, drinking water fountains, urinals and water closets shall be as follows:

(1) for sink and lavatory faucets, a constant water pressure of sixty pounds per square inch, and a maximum flow not to exceed three gallons of water per minute; faucet models installed in public buildings or facilities must be of a self-closing variety and shall comply with reference standard RS 4-6;

(2) for shower heads, a constant water pressure of sixty pounds per square inch, and a maximum flow not to exceed three gallons of water per minute;

(3) for urinals and associated flush-valves, if any, each flush shall not exceed one gallon of water per flush;

(4) for water closets and associated flush-valves, if any, each flush shall not exceed three and one half gallons of water per flush except that on and after January first, nineteen hundred ninety-two, each flush shall not exceed one and three-fifths gallons of water per flush; and

(5) drinking water fountains shall be of a self-closing variety and shall comply with reference standard RS 4-6.

(c) Permanent product markings shall be required on all water closets and urinals, or each fixture component if the fixture is comprised of more than one component, located in an easily recognizable location. Such markings

Reference Standard 16

shall be legible, applied so as to be permanent and provide the following information:

- i. the manufacturer's name or registered trademark and the model number of the fixture or fixtures; and
 - ii. the gallon/liter water consumption rate per flush of the water closet or urinal; and
 - iii. with respect to tank type water closets, a clear marking of and designation for the "water line" shall be located within the tank which shall be set at the level of gallons/liters per flush required for the water closet.
- (d) The commissioner shall annually publish a list of fixtures which meets the standards specified in paragraph b of this subdivision which are certified by manufacturers pursuant to i. of subparagraph three of paragraph a and which are not included on the "list of certified water saving fixtures" published pursuant to section 15-0314 of the environmental conservation law. A notice of the availability of such list shall be published in the city record. The commissioner shall delete from such list fixtures which are determined to be inaccurately certified.**
- (e) The provisions of this subdivision shall not apply to fixtures such as safety showers and aspirator faucets, which in order to perform a specialized function, cannot meet the standards specified in paragraph b of this subdivision.**
- (f) Access for cleaning.-**Plumbing fixtures shall be so installed as to afford easy access for cleaning both the fixture and the area about it. All pipes from fixtures shall be run to the nearest wall, except where it is impractical to do so.
- (g) Sealing.-**Where fixtures come in contact with wall or floors, the space between the fixture and the wall shall be sealed against water seepage.
- (h) Securing floor outlet fixtures.-**Floor outlet fixtures shall be rigidly secured to the floor or floor flanges by stainless steel, acetyl plastic, or non-ferrous screws or bolts.
- (i) Securing wall-hung bowls.-**Wall-hung water closet bowls shall be rigidly supported by a concealed metal supporting member so that no strain is placed on the closet connection.
- (j) Water supply protection.-**The supply lines or fittings for every plumbing fixture shall be so installed as to prevent backflow. See Section P107.0.

†*Local Law 29-1989*

P104.3 Overflows.-

- (a) Design of overflows.-**In any fixture that is provided with an overflow, the waste outlet shall be designed and installed so that the standing water in the fixture cannot rise in the overflow when the stopper is closed, nor shall any water remain in the overflow when the fixture is empty.
- (b) Connection of overflows.-**The overflow from any fixture shall discharge into the drainage system on the inlet or fixture side of the trap. The overflow from a flush tank serving a water closet or urinal shall discharge into the fixture served.

†P104.4 Water Closets.-

(a) Prohibited water closets.-

- (1) Washout, pan, valve, plunger, offset, latrine, and

side spud water closets shall be prohibited. Water closets that have an invisible seal, an unventilated space, or walls that are not thoroughly washed at each discharge, shall be prohibited. Any water closet that might permit a siphonage of the contents of the bowl back into the water supply system shall be prohibited.

(2) Frostproof water closets will be permitted by the commissioner for temporary installations only.

(b) Water closets for public use.-Water closet bowls for public use shall be of the elongated type.

(c) Water closets for children's use.-In nurseries, schools, and similar places where plumbing fixtures are provided for the use of children under six years of age, water closets shall be of a size and height suitable for the children's use.

(d) Water closet seats.-Water closets shall be equipped with seats of smooth nonabsorbent material. All seats of water closets provided for public use shall be the open-front type. Integral water closet seats shall be of the same material as the fixture.

(e) Water closet soil pipe connections.-

(1) **LEAD CONNECTIONS.-**Lead bends and stubs may be used on water closets or similar connections, provided the lead is soldered to the floor flange.

(2) **IRON CONNECTIONS.-**3 in. iron bends may be used on water closets or similar connections, provided a 4 in. x 3 in. flange is used to receive the fixture horn.

(3) **COPPER CONNECTIONS.-**3 in. copper bends may be used on water closets or similar connections, provided a 4 in. x 3 in. flange is used to receive the fixture horn.

(4) **OTHER TYPE CONNECTIONS.-**Connections of other equivalent materials will be permitted.

(5) **REDUCING BENDS.-**4 in. x 3 in. reducing bends may be used.

†*Local Law 29-1989*

P104.5 Urinals.-

(a) Prohibited urinals.-

(1) Floor-type trough urinals are prohibited.

(2) Washdown or washout type urinals that have integral strainers are prohibited.

(b) Wall-hung trough urinals.-Wall-hung trough urinals shall be permitted only in temporary locations. They shall be at least 6 in. deep and shall be furnished with one-piece backs and have strainers with outlets at least 1 1/2 in. in diameter. The washdown pipe shall be perforated so as to flush with an even curtain of water against the back of the urinal. This pipe shall be securely clamped as high as practicable to the back of the urinal. Trough urinals shall have tanks with a flushing capacity of at least 1 1/2 gal. of water for each 2 ft. of urinal length. Troughs shall be figured on the basis of one urinal for each 18 in. of length; e.g.,

24 in. trough equals 1 urinal
36 in. trough equals 2 urinals
48 in. trough equals 2 urinals
60 in. trough equals 3 urinals
72 in. trough equals 4 urinals

Reference Standard 16

(c) **Surrounding material.**-Wall and floor space to a point 1 ft. in front of a urinal lip and 4 ft. above the floor, and at least 1 ft. to each side of the urinal shall be finished with smooth, readily cleanable, nonabsorbent material.

P104.6 Flushing Devices for Water Closets and Urinals.-

(a) **Where required.**-Each water closet, urinal, clinical sink, or other plumbing fixture that depends on trap siphonage to discharge its waste contents to the drainage system to which it is connected, shall be provided with a flushometer valve, flush tank, or similar device designed and installed so as to supply water in sufficient quantity and rate of flow to flush to the sewer the contents of the fixture to which it is connected, to cleanse the fixture, and to refill the fixture trap in a single flushing operation.

(b) **Number of fixtures served.**-A flushing device shall serve only one fixture except that a single flushing device may be used to flush more than one urinal when it is designed so that the flushing cycle is controlled automatically and so that each urinal or section thereof is thoroughly flushed.

(c) **Flushometer valves.**-Flushometers shall be installed so that they will be readily accessible for repair. Flushometer valves shall not be used where the water pressure is insufficient to properly operate them. When the valve is operated, it shall complete the cycle of operation automatically, opening fully and closing positively under the water line pressure. Each flushometer shall be provided with a means for regulating the flow through it. Each flushometer valve supplying a submerged inlet without a required air gap shall be provided with an approved vacuum breaker set at least 4 in. above the overflow rim of the fixture to the critical level marked on the vacuum breaker as determined by test.

(d) Flush tanks.-

(1) **WATER SUPPLY.**-An adequate supply of water shall be provided to flush and clean the fixture served. The water supply to flush tanks equipped for automatic flushing shall be controlled by a suitable timing device. The water supply to flush tanks equipped for manual flushing shall be controlled by a float valve or other automatic device designed to refill the tank after each discharge and to completely shut off the water flow to the tank when the tank is filled to operational capacity. Provision shall be made to provide an adequate supply of water to the fixture so as to refill the trap seal after each flushing.

(2) **BALL COCKS.**-Ball cocks in flush tanks for water closets shall be located at least 1 in. above the flood level rim of the bowl connected thereto, and shall be provided with a vacuum breaker.

(3) **OVERFLOWS.**-Flush tanks shall be provided with overflows discharging to the water closet or urinal connected thereto, and shall be of sufficient size to

prevent flooding the tank at the maximum rate at which the tanks are supplied with water.

P104.7 Lavatories.-

(a) **Waste outlets.**-Lavatories shall have waste outlets at least 1 1/4 in. in diameter.

(b) **Multiple-type fixture.**-Each 18 in. unit of usable length of a straight-line type multiple-use lavatory and each 18 in. of usable length of a circular type multiple use lavatory shall be considered equivalent to one lavatory for the purpose of determining the drainage and water supply piping sizes and fixture usage requirements provided hot and cold or tempered water suitable for handwashing is available for each 18 in. interval.

P104.8 Bathtubs.-

(a) **Waste outlets and overflows.**-Bathtubs shall have waste outlets and overflows at least 1 1/2 in. in diameter, and the waste outlet shall be equipped with a suitable stopper.

P104.9 Showers.-

(a) **Waste outlet.**-Waste outlets serving single showers, other than those in bathtubs, shall be at least 2 in. in diameter, and when serving a gang shower shall be at least 3 in. in diameter. Drains shall have removable strainers with a free area no smaller than the cross-sectional area of the drain pipe connected thereto and openings no smaller than 1/4 in. in minimum dimension. Unless each shower head is provided with an individual waste outlet, the waste outlet must be so located and the floor so pitched that waste water from one shower head does not flow over the floor area serving another shower head.

(b) **Shower compartments.**-Shower compartments shall have at least 900 sq. in. of floor area and shall be at least 30 in. in minimum dimension measured as the side of a rectangle, altitude of a triangle or other angular shape, or as diameter of a circle, except when a bathtub is used as the shower compartment. The wall area above built-in tubs having installed shower heads and in shower compartments shall be constructed of smooth, noncorrodible, nonabsorbent, waterproof materials to a height of at least 6 ft. above the floor level. Such walls shall form a watertight joint with each other and with either the tub, receptor, or shower floor.

(c) **Shower floors or receptors.**-Floors or receptors under shower compartments shall be laid on a smooth and structurally sound base. Floors under shower compartments, other than those laid directly on the ground surface or where prefabricated receptors have been provided, shall be lined and made watertight by the provisions of suitable shower pans of durable material. Such pans shall turn up on all sides at least 2 in. above the finished shower floor level. Pans shall be securely fastened to the waste outlet at the seepage entrance, making a watertight joint between the pan and the outlet. Floor surfaces shall be constructed of smooth, noncorrodible, nonabsorbent, and waterproof materials.

Reference Standard 16

P104.10 Sinks.-

(a) **Waste outlets.**-Sinks shall be provided with waste outlets at least 1 1/2 in. in diameter.

(b) **Food waste disposals.**—Sinks equipped with food waste disposals shall have waste outlets at least equal to the opening in the disposals.

**Local Law 74-1995*

P104.11 Dishwashing Machines.-

(a) **General.**-A separate trap shall be provided for a dishwashing machine that drains by gravity.

(b) **Domestic machines.**-Machines having drainage pumps may discharge into the waste outlet piping of an adjacent kitchen sink by means of a wye branch fitting on the inlet side of the sink trap, provided the pump discharge line rises to an elevation above the flood level rim of the sink and is at least 3/4 in. in diameter.

(c) **Water connections.**-Water connections to a dishwasher shall be provided with an air gap or an approved vacuum breaker and check valve.

(d) **Commercial dishwashers.**-Commercial dishwashing machines shall be provided with an adequate supply of 140°F to 160°F wash water, and with rinse water or steam at temperature of at least 180°F for sterilization. Chemical disinfection may be used in lieu of the 180°F water or steam when the method of disinfection meets the requirements of the department of health.

P104.12 Automatic Clothes Washers.-

(a) The water supplies to an automatic clothes washer shall be protected against the hazards of contamination by means of an adequate air gap or a vacuum breaker.

(b) The discharge waste pipe of domestic clothes washers shall be provided with an air break by spilling the discharge into an open standpipe that is provided with a 2 in. trap. The trap shall be properly vented or connected to an indirect waste pipe that may be common to other automatic clothes washers located in a common laundry room.

(c) The discharge waste pipe of commercial clothes washers shall discharge into a trench provided with trapped and vented drains.

P104.13 Laundry Trays.-Each compartment of a laundry tray shall be provided with a waste outlet at least 1 1/2 in. in diameter.

P104.14 Garbage Can Washers.-

(a) The drain outlet receiving the wash from garbage cans shall be at least 3 in. and shall be provided with a removable basket or strainer to prevent discharge of large particles into the building drainage system.

(b) Water supply connections shall be provided with an air gap or an approved backflow prevention device and check valve.

P104.15 Fixture strainers.-Plumbing fixtures except water closets, urinals, or similar fixtures shall be provided with durable crossbars, strainers, or other similar devices installed in the fixture waste outlet. Such strainers shall have waterway areas adequate for rapid fixture drainage.

*P104.16 Drinking Fountains.-

(a) **Construction.**-Drinking fountains shall conform to **ASA-Z4.2-1942.

(b) **Equivalent fixtures.**-A lavatory located in a room with not more than one water closet or urinal will be an acceptable equivalent for a drinking fountain for the purpose of fixture requirements.

(c) **Prohibited drinking fountains.**-No electric coolers that have precooling coils inside of the waste outlets will be permitted except as hereinafter provided. The precoolers must be of double wall construction and mounted in a vertical position directly below a removable strainer in the cooler top and the precooler shall be fully accessible for cleaning with an ordinary bottle brush. Except for a water spreader at the entrance of the precooler drain tube, no internal dimension of the drain passage shall be less than 3/4 in.

** This title not enacted but probably intended.*

*** As enacted but "ANSI-Z4.2-1942." probably intended.*

P104.17 Floor Drains.-

(a) **Location.**-The floor drain shall be located so as to be readily accessible at all times.

(b) **Strainers.**-Floor drains shall be provided with removable strainers, the open area of which shall be at least equal to the cross-sectional area of the drain pipe to which the drain connects. Combination funnel and floor drain strainers will be permitted.

(c) **Size.**-Floor drains shall be of a size to efficiently serve the purpose for which they are intended, but the outlet pipe shall not be less than 3 in. in nominal diameter.

(d) **Provision for evaporation.**-Traps for floor drains shall be of the deep seal type, and shall have a water supply available from a plumbing fixture located in the same room or from a faucet or valved outlet located not more than 3 ft. above the floor drained. Automatic priming devices will be permitted only when an air gap is provided between the potable water supply and the water supply for the drain.

(e) **Traps.**-Machinery or equipment room floor drains that receive clear water only may be connected to a single trap where such trap is located not more than 15 ft. from the farthest drain.

P104.18 Drains for Drip Pipes. -See section P108.11.

P104.19 Funnel Drains.-When the trap is located above the floor, the funnel drain shall be individually vented. Funnel drains shall only be used for clear water wastes.

P104.20 Special Plumbing Fixtures.-

Reference Standard 16

(a) Water connections.-Baptisteries, ornamental and lily pools, aquaria, ornamental fountain basins, swimming pools, and similar constructions, when provided with water supplies, shall be protected from back-siphonage in conformity with the code requirements.

(b) Approval.-Specialties requiring water and waste connections shall be subject to approval by the Commissioner.

Section P105.0 Traps and Cleanouts

P105.1 Fixture Traps.-

(a) Separate traps for each fixture.-Each plumbing fixture shall be separately trapped by a water seal trap placed as close as possible to the fixture outlet, but not more than 2 ft. horizontal developed length from the outlet of the fixture. The vertical distance from the fixture outlet to the trap weir shall not exceed 48 in. No fixture shall be double trapped. Exceptions to the separate trapping requirements are as follows:

(1) Fixtures having integral traps.

(2) A combination plumbing fixture may be installed on one trap provided one compartment is not more than 6 in. deeper than the other and the waste outlets are not more than 30 in. apart, and provided the trap is centrally located between the waste outlets.

(3) One trap may be installed for a three compartment sink, three single laundry trays, or a combination of one sink and two trays immediately adjacent to each other in the same room, provided the trap is centrally located between the three sections.

(4) A domestic dishwasher located with a developed length of drain not more than 3 ft.-6 in. from the trap serving a kitchen sink or combination sink and tray may be connected to the fixture side of the sink trap. A dishwasher may also be connected as stated in section P104.11(b).

(5) No trap need be provided at fixtures and equipment that discharge their wastes indirectly into a trapped receptacle through a drainage pipe not exceeding 8 ft. in developed length, measured from the drainage outlet. No traps shall be provided for safety relief apparatus, condenser blow-offs, and similar drain lines.

(b) Fixture trap sizes.-Fixture trap sizes (nominal diameter) shall be sufficient to drain the fixture rapidly and in no case less than the sizes given in Table RS 16-6. No trap shall be larger than the drainage pipe into which it discharges.

(c) Prohibited traps.-The following types of traps are prohibited:

(1) Traps that depend upon moving parts to maintain their seal.

(2) Bell, pot, bottle traps, and traps with interior partitions.

(3) Crown vented traps.

(4) Traps constructed of masonry.

(5) Catch basins located within the building.

(d) Design.-All fixture traps, except grease and sediment interceptors, shall be self-scouring. Traps integral with

the fixtures shall have a uniform interior and smooth waterway. Traps shall have no interior partitions except where such traps are integral with the fixture or are designed as interceptors. Slip joints or couplings may be used on the inlet side of the trap and a ground joint union connection may be installed in the trap seal.

(e) Seals.-Each fixture trap shall have a liquid seal of at least 2 in. but not more than 4 in.

(f) Setting and protection.-Traps shall be set level with respect to their water seals and, where necessary, shall be protected from freezing and evaporation.

*****P105.2 Building (House) Traps.**-Shall be installed on all building drains near the foundation wall of the structure, inside of the street line, and on the sewer side of all connections, except the connection used to receive the discharge from a sewage ejector, oil separator or leader on combined systems. If such trap is placed outside of the foundation wall or below a cellar floor, it shall be made accessible in a manhole with a cover, or by extension of the two handholes that shall be provided with cleanouts at the cellar floor or grade. Handhole extensions shall be not more than 18 in. above the centerline of the drain. Building (house) traps shall be the same size as the building house drain connected thereto. Where manufactured cast iron traps are not available AWWA cast iron water pipe or ductile iron may be used for house traps if the trap is made with long turn fittings and TY's.

*****Local Law 63-1976**

Reference Standard 16

***TABLE 16-5 MINIMUM NUMBER OF PLUMBING FIXTURES REQUIRED^a**

| Type of Building Occupancy | TYPE OF FIXTURE | | | | | | | |
|---|---|------------------------------|--|--|-----------------|--|--|--|
| | Water Closets | | Urinals | Lavatories | | Bathtubs or Showers | Drinking Fountains | Other Fixtures |
| Assembly – places of worship ^b | 1 for each sex for each 150 persons | | Urinals may be provided in toilet rooms in lieu of water closets but for not more than 1/2 of the required number of water closets | 1 | | | | |
| Assembly – other than places of worship (including but not limited to auditoriums, theaters, convention halls) and all spaces classified as F-4 | No. of Persons | No. of Fixtures for each Sex | Urinals may be provided in toilet rooms in lieu of water closets but for not more than 1/2 of the required number of water closets | No. of Persons | No. of Fixtures | | 1 for each 1,000 persons except that there shall be at least 1 fixture at each assembly floor, level or tier | Where motion picture projection booths contain more than 2 projectors, at least 1 water closet and 1 lavatory shall be provided on the same level and within 20 ft. of the booth |
| | 1-100 | 1 | | 1-200 | 1 | | | |
| | 101-200 | 2 | | 201-400 | 2 | | | |
| | 201-300 | 3 | | 401-750 | 3 | | | |
| | 301-400 | 4 | | Over 750, add 1 fixture for each 500 persons | | | | |
| | Over 400, add 1 fixture for each additional 200 persons | | | | | | | |
| Dormitories – schools or labor, also institutional | 1 for each sex for each 8 persons | | Urinals may be provided in toilet rooms in lieu of water closets but for not more than 1/2 of the required number of water closets | 1 for each 12 persons | | 1 for each 8 persons: for women’s dormitories, 1 bathtub shall be substituted for 1 shower at the ratio of 1 for each 30 women | | Laundry trays – 1 for each 50 persons |
| Single room occupancies for sleeping accommodations only | 1 for each 6 persons | | | 1 for each 6 persons | | 1 for each 6 persons | | |
| Dwellings- one- and two-family | 1 for each dwelling unit | | | 1 for each dwelling unit | | 1 for each dwelling unit | | Kitchen sink— 1 for each dwelling unit |
| Public buildings, offices, business mercantile, storage; warehouses, factories and institutional employees ^c | No. of Persons for each sex | No. of Fixtures | Urinals may be provided in toilet rooms in lieu of water closets but for not more than 1/2 of the required number of water closets when more than 35 persons | No. of Persons | No. of Fixtures | | 1 for each 75 persons | |
| | 1-15 | 1 | | 1-20 | 1 | | | |
| | 16-35 | 2 | | 21-40 | 2 | | | |
| | 36-55 | 3 | | 41-60 | 3 | | | |
| | 56-80 | 4 | | 61-90 | 4 | | | |
| | 81-110 | 5 | | 91-125 | 5 | | | |
| | 111-150 | 6 | | 1 fixture for each additional 45 persons | | | | |
| Public bathing | 1 fixture for each sex for each 30 persons | | Urinals may be provided in toilet rooms in lieu of water closets but for not more than 1/2 of the required number of water closets | 1/60 | | 1/40 | | |

Reference Standard 16

***TABLE 16-5 MINIMUM NUMBER OF PLUMBING FIXTURES REQUIRED^a (Continued)**

| Type of Building Occupancy | TYPE OF FIXTURE | | | | | |
|--|--|--|---|--|--|----------------|
| | Water Closets | Urinals | Lavatories | Bathubs or Showers | Drinking Fountains | Other Fixtures |
| Schools: Elementary Secondary | 1 fixture for each sex for each 35 students | Urinals may be provided in toilet rooms in lieu of water closets but for not more than 1/2 of the required number of water closets | 1/50 pupils 1/50 pupils Over 300 pupils 1/100 pupils | In gym or pool shower rooms, ¼ pupils of the largest class using pool at any one time | 1/50 persons but at least 1 per floor | |
| Workers portable facilities | 1/30 workers | 1/30 workers | | | At least 1 per floor equivalent for each 100 workmen | |
| Industrial - foundries only | No. of Persons No. of Fixtures 1-10 1 11-25 2 26-50 3 51-80 4 81-125 5 1 additional fixture for each additional 45 persons | Where more than 10 men are employed: No. of Men ^c No. of Urinals 11-29 1 30-79 2 1 additional fixture for each additional 80 males. Urinals may be provided in toilet rooms in lieu of water closets but for not more than ½ of the required number of water closets | No. of Persons No. of Fixtures 1-8 1 9-16 2 17-30 3 31-45 4 46-65 5 1 additional fixture for each additional 25 persons | 1 shower for each 15 persons exposed to excessive heat or occupational hazard from poisonous, infectious, or irritating material | 1 for each 75 persons | |
| Hospital and Institutions, See Section P114.0 | | | | | | |
| Swimming pools, See Section P116.0 | | | | | Other Fixtures | |
| Kitchens for public or employees dining | | | 1 lavatory for the personal use of kitchen employees | | One machine or a 3-compartment sink for the effective washing and sanitizing of all cutlery, dishes and glasses before re-use. | |
| Dwellings—multiple or apartment | 1 for each dwelling unit or apartment | | 1 for each dwelling unit or apartment | 1 for each dwelling unit or apartment | Kitchen sink- 1 for each dwelling unit or apartment. Within each dwelling unit, not designed for use by transients, one laundry tray or automatic laundry washing machine; or in a readily accessible location within a general laundry room, 1 two-compartment tray for each 10 dwelling units or 1 automatic laundry washing machine for each 20 dwelling units. | |
| <p>Notes for Table 16-5:</p> <p>^aThe population used in determining the number of fixtures required shall be based on the number of people to occupy the space but in no case shall the population be less than that determined by allowing 125 sq. ft. of net floor area per person.</p> <p>^b Such facilities may be in adjacent buildings under the same ownership or control, and shall be accessible during periods when the assembly space is occupied.</p> <p>^c Facilities for employees in a storage building or warehouse may be located in an adjacent building, under the same ownership, where the maximum distance of travel from the working space to the toilet facilities does not exceed 500 ft. horizontally.</p> <p><i>*Local Law 45-1984; Local Law 61-1969</i></p> | | | | | | |

TABLE 16-6 MINIMUM SIZE OF FIXTURE TRAPS FOR VARIOUS TYPES OF PLUMBING FIXTURES

| Fixture | Trap Size ^{a,b} (In.) |
|---|--------------------------------|
| Bathtub (with or without overhead shower) | 1 1/2 |
| Bidets (see section P107.13)..... | 1 1/2 |
| Combination sink and wash (laundry) tray | 2 |
| Dental unit or cuspidor | 1 1/2 |
| Drinking fountain | 1 1/2 |
| Dishwasher, commercial..... | 2 |
| Dishwasher, domestic | 1 1/2 |
| Floor drain | 3 |
| Funnel drain..... | 1 1/2 |
| Kitchen sink, domestic | 2 |
| Laboratory, cup sink..... | 1 1/2 |
| Laboratory, sink..... | 2 |
| Lavatory, common..... | 1 1/2 |
| Lavatory, barber shop, beauty parlor or surgeon's..... | 1 1/2 |
| Lavatory, multiple type (wash fountain or wash sink)..... | 1 1/2 |
| Laundry tray (1 or 2 compartments)..... | 1 1/2 |
| Shower, stall | 2 |
| Shower, gang | 3 |
| Sink (surgeon's) | 1 1/2 |
| Sink (flushing rim type, flush valve supplies) | 3 |
| Sink (service type with trap standard) | 3 |
| Sink, commercial (pot, scullery, or similar type)..... | 2 |
| Sterilizers | 1 1/2 |
| Urinal (pedestal) | 3 |
| Urinal (stall type)..... | 2 |
| Urinal (wall lip type) | 2 |
| Urinal (women's) | 3 |
| Water closet (waste outlet) | 3 |

Notes-

^a Size of outlet, the inlet size of trap same as outlet from fixture.

^b Size of three lavatory equivalents-2 in. for more than three.

P105.3 Drainage Pipe Cleanouts.-

(a) **Location.**-Cleanouts shall be not more than 50 ft. apart in horizontal drainage lines.

(b) **Underground drainage.**-Cleanouts, when installed on an underground drain, shall be extended vertically and made accessible at the floor, grade, or wall.

(c) **Change of direction.**-Accessible cleanouts shall be installed at each change of direction greater than 45° on all horizontal pipes of the drainage system.

(d) **Base of stacks.**-A cleanout shall be provided at, or near, the foot of each vertical inside leader and waste or soil stack.

(e) **Direction of flow.**-Every cleanout shall be installed so that the cleanout opens in the direction of flow of the drainage line or at right angles thereto.

(f) **Size.**-Cleanouts shall be of the same nominal size as the pipes for pipes up to 4 in., and not less than 4 in. for larger piping.

(g) **Clearances.-**

(1) Cleanouts on 3 in. pipes or larger shall be installed

so as to provide clearance of at least 18 in. for the purpose of rodding.

(2) Cleanouts smaller than 3 in. shall be installed so as to provide a 12 in. clearance for rodding.

(h) **Kept uncovered.**-Cleanout plugs shall not be covered with cement, plaster, or any other permanent finishing material. Where it is necessary to conceal a cleanout plug, a covering plate or access door shall be provided that will permit ready access to the plug.

(i) **Equivalent cleanouts.**-Fixtures with integral traps, such as water closet and pedestal urinals, or a fixture trap that is readily removable without disturbing concealed roughing work, may be used as a cleanout providing there is no more than one 90 degree bend or sanitary tee on the line to be rodded.

P105.4 Interceptors, Separators, and Neutralizing Pits.-

(a) **Interceptors required.**-Interceptors or neutralizing facilities of required size and type shall be provided, as

Reference Standard 16

specified herein, for extracting oil, grease, sand, and other substances, harmful or hazardous to the building drainage system, the public sewers, or sewer system as defined in the regulation and the industrial waste permit issued by the department of public works.

(b) Interceptors not required.-A grease interceptor is not required for individual dwelling units or any private living quarters.

(c) Separators required.-At repair garages, gasoline stations with grease racks, grease pits, work racks, and at factories where oily and/or flammable liquid waste are produced, separators of required size and type shall be installed into which all oil-bearing, grease-bearing, and/or flammable wastes shall be discharged before emptying into the building drainage system or other point of disposal. A sand interceptor shall be provided for auto laundries, and no oil separator shall be required.

(d) Grease interceptors.

(1) **COMMERCIAL BUILDING.**-A grease interceptor, meeting the provisions of this reference standard, shall be installed in the waste line leading from pot sinks, scullery sinks, food scrap sinks, floor drains receiving waste or spillage from soup or stock kettles, and the scraper section of commercial dishwashers in all restaurants, kitchens, cafeterias, clubs, or other establishments where grease can be introduced into the drainage system. No rinse water at a temperature of 180^oF or higher shall discharge through the interceptor.

(2) **NUMBER OF GREASE INTERCEPTORS.**-One interceptor shall be permitted for all fixtures requiring the interceptor, provided it is individually trapped and vented, and an additional vent is installed at the interceptor, and provided the size of the interceptor is sufficient to accommodate all of the fixtures connected thereto.

(3) **USE AS A TRAP.**-The interceptor may be used in lieu of an individual fixture trap if the developed length from the fixture outlet to the inlet of the interceptor is not more than 48 in.

(4) **CAPACITY.**-Grease interceptors shall have a grease retention capacity, in lbs. equal to at least twice the numerical flow-through rating in gpm (i.e., 2 gpm=4 lbs.). The minimum flow-through rating of grease interceptors shall be equal to the maximum value of all sinks and receptacles that may flow simultaneously through the interceptor divided by the average time for the sinks and receptacles to empty. Interceptors shall remove an average at least of 90 percent of the grease of other extractable matter in the waste water and shall conform with the requirements of the department of public works.

(5) **MATERIAL.**-All prefabricated grease interceptors shall be approved.

(e) Oil and flammable liquids separator.

(1) **SEPARATION OF LIQUIDS.**-A mixture of light and heavy liquids having various specific gravities, such as petroleum hydrocarbons in water, may be treated and then separated in a receptacle complying with the provisions of this reference standard.

(2) **DESIGN OF SEPARATOR.**

a. **Overall requirements.**-Oil separators shall have a depth of at least 2 ft. below the invert of the discharge drain connected thereto. The outlet opening of the separator shall have at least an 18 in. water seal.

b. **Motor vehicle occupancies.**-In automotive service stations, automotive repair shops, and public garages (group I) where not more than four motor vehicles are both serviced and stored, separators shall have a minimum capacity of 6 cu. ft. and 1 cu. ft. capacity shall be added for each vehicle up to ten vehicles. Above ten vehicles, the size of the separator shall be determined by an architect or engineer, subject to the approval of the Commissioner. Where vehicles are serviced only and not stored, separator capacity shall be based on net capacity of 1 cu. ft. for each 100 sq. ft. of surface to be drained into the separator, with a minimum of 6 cu. ft.

c. **Other occupancies.**-In other buildings where oil or other flammable liquids are stored or used, no physical connection or internal arrangement that could permit the accidental or deliberate introduction of such materials directly or indirectly into the sewer system will be permitted. Where such substances might overflow by spillage or other circumstance not attributable to a direct connection of the plumbing system, every precaution shall be taken through the presence of protective dikes and similar devices to prevent such substances from reaching the public sewers.

(3) **VENTING.**-Oil separators shall be vented in accordance with Section P105.6.

(4) **CONNECTION TO SEWER.**-The discharge of an oil separator shall be independently connected to the street sewer or to the sewer side of the house trap. Where the oil separator is located below the street sewer, the sump receiving the effluent from the separator shall be gasketed and vented in the same manner as the separator.

(5) **OIL STORAGE TANK.**-Each separator shall have an oil storage tank available for storing the residue from the separator. Tanks shall be installed in accordance with Article 14.

P105.5 Interceptors, Separators, and Neutralizing Pits for Specific Services.

(a) Sand interceptors-commercial establishments.-Sand and similar interceptors for heavy solids shall be so designed and located as to be readily accessible for cleaning, and shall have a water seal of at least 6 in.

(b) Laundries.-Commercial laundries shall be equipped with an interceptor having a wire basket or similar device that is removable for cleaning, and that will prevent passage into the drainage system of any solids 1/2 in. or larger in size, or strings, rags, buttons, or other materials detrimental to the public sewerage system. Interception within a trough will be permitted.

(c) Bottling establishments.-Bottling plants shall discharge their process wastes into an interceptor that will intercept broken glass and other solids before discharging liquid wastes into the drainage system.

Reference Standard 16

(d) Slaughter houses.-Slaughtering room and dressing room drains shall be equipped with separators or interceptors that shall prevent the discharge into the drainage system of feathers, entrails, and other materials likely to close the drainage system.

(e) Laboratories, dyeworks, and chemical plants.-In establishments discharging sewage, industrial wastes, or other wastes that will reduce the pH value of the waste water discharged to the public sewer system below 4.5 or raise it to above 11.5 at the point or points of such discharge, provisions shall be made for neutralizing such waste water to conform with the regulations of the department of public works. Where applicable, a suitable neutralizing pit shall be installed that is of sufficient capacity to hold an adequate quantity of marble chips or similar neutralization substance to satisfactorily bring the pH value of the waste water to acceptable values. Baffles and other flow guiding devices may be introduced to insure that the acid or alkaline wastes are thoroughly contacted by the neutralizing substance. The venting arrangement for this pit shall be in conformance with the applicable provisions of this code.

P105.6 Venting of Interceptors, Separators, and Neutralizing Pits.-

(a) Oil interceptors and separators.-

(1) Interceptors and separators shall be so designed that they will not become air bound if closed covers are used. Each interceptor or separator shall have an individual 3 in. vent extending from the top of the separator to the outside air at a point at least 12 ft. above street level.

(2) A fresh air inlet shall be provided from the drain line at the inlet side of the separator to the outside air at a point at least 6 in. above grade.

(3) A separator shall be accepted in lieu of a house trap.

(4) The horizontal drain line and at least one stack shall be at least 3 in. in diameter. Stack shall be carried full size through the roof.

(b) Neutralizing pits and interceptors (other than oil).-Interceptors, separators, and neutralizing pits shall be so designed that they will not become air bound if closed covers are used. Each interceptor that is provided with a cover shall be vented, and the vent may connect into the sanitary vent system.

P105.7 Accessibility of Interceptors, Separators and Neutralizing Pits.-Each interceptor, separator, and neutralizing pit shall be so installed that it is readily accessible for removing the cover, for servicing, and for maintenance.

P105.8 Maintenance of Interceptors, Separators, and Neutralizing Pits.-Interceptors, separators, and neutralizing pits shall be maintained in efficient operating condition by periodic removal of accumulated grease, scum, oil, or other floating substances, and solids deposited in the interceptor, separator, or neutralizing pit. Improper maintenance of interceptor, separator, or neutralizing pit

may constitute sufficient cause for revocation of the industrial waste permit for the premises issued by the department of public works or may constitute a violation of the fire prevention code.

P105.9 Backwater Valves.-

(a) Fixtures and area drains subject to backflow.-

Where fixtures, floor drains, or area drains are subject to overflow as the result of backwater from the public sewer system, accessible backwater valves shall be installed in the fixture drain pipe from such fixture, in the branch drain to such area drain or group of fixtures, or in the building drain at its point of exit from the building and downstream from the building trap. Masonry access manholes shall be provided when the centerline of any drain line is 18 in. or more below a slab on grade.

(b) Design.-Backwater valves shall provide a positive mechanical seal against backwater, and when fully opened shall have the same discharge flow capacity as the pipe in which it is installed. All bearing parts shall be made of corrosion resistant metal or other equivalent material. The flap shall be so designed as to hang partially open when not subject to backwater pressure.

P105.10 Industrial Wastes Sampling Manholes.-

All premises intended for the discharge of sewage, industrial wastes, or other wastes with characteristics that do not conform to those prescribed for normal sewage as defined in regulations promulgated by the department of public works, shall contain a suitable common control manhole into which all flow of sewage, industrial wastes, or other wastes are combined. When the installation of such a common manhole is impossible, impractical, or will interfere with treatment facilities required for the issuance of an industrial waste permit by the department of public works, the owner of such premises shall construct, in lieu of the common manhole, two or more manholes as required by the department of public works, for accurate measurement of all flows of sewage, industrial wastes, or other wastes before discharging from such premises into the sewer system.

Section P106.0 Hangers and Supports

P106.1 Material.-Hangers, anchors, and supports shall be of metal or equivalent material of sufficient strength to support the piping and its contents. Piers may be of concrete, brick, or equivalent material.

P106.2 Attachment to Building.-Hangers and anchors shall be securely attached to the building construction at sufficiently close intervals to uniformly support the piping and its contents.

P106.3 Intervals of Supports.-

(a) Vertical piping.-Vertical piping of the following materials shall be supported, using either guide or friction hangers or a combination of both, at the following intervals:

Reference Standard 16

- (1) Cast iron soil pipe at base and at each story height, but in no case at intervals greater than 20 ft.
- (2) Threaded pipe (SPS).-At every other story height, but in no case at intervals greater than 25 ft.
- (3) Copper tubing (hard temper).-At each story height.
- (4) Other materials.-As required for structural stability and service.

(b) Horizontal piping.-Horizontal piping of the following materials shall be supported at intervals no greater than the following:

- (1) Cast iron soil pipe.-At 5 ft. intervals and behind every hub.
- (2) Threaded pipe (1 in. or less).-At 8 ft. intervals.
- (3) Threaded pipe (1 1/4 in. or over).-At 12 ft. intervals.
- (4) Copper tubing (1 1/4 in. or less).-At 6 ft. intervals.
- (5) Copper tubing (1 1/2 in. or over).-At 10 ft. intervals.
- (6) Other materials.-As required for structural stability and service.

(c) Base of stacks.-Bases of cast iron stacks shall be supported on concrete, on brick laid in cement mortar, by metal brackets attached to the building construction, or by equivalent methods. Stacks of other material shall be anchored so as to relieve the load from the base of the stack.

***P106.4 Installation of no-hub type cast iron soil pipe, fittings, and couplings.-**

All installations of no-hub type cast iron soil pipe, fittings and couplings shall comply with the following: CISPI Designation 310-1985 Specification for Cast Iron Soil Pipe Institute's Approved Coupling for Use in Connection with Hubless Cast Iron Soil Pipe and Fittings for Sanitary and Storm Drain, Waste, and Vent Piping Applications.

**Local Law 100-1989*

Section P107.0 Water Supply and Distribution

P107.1 Permits.-

- (a) Permits for all water supplies for all buildings or for demolitions shall be obtained from the department of water supply, gas, and electricity. The installation of the water service system from the street main up to and including the meter setting when meters are required, or up to the house control valve when no meters are required, shall be subject to inspection and approval by the department of water supply, gas and electricity.
- (b) Permits for sidewalk and street openings shall be obtained from the department of highways.

P107.2 Water Service.-

(a) Taps to city water mains.-

- (1) SEPARATE SUPPLY.-A separate tap and service shall be installed for each building fronting on a street in which there is a city (street) water main, and no consumer will be allowed to supply water to other persons or premises, except in a project where more than one building under a single ownership is supplied from a common house tank or booster system located in or on one of the buildings.

(2) CONNECTIONS TO CITY (STREET) MAINS.- Corporation stops, wet connections, or other connections to a street main shall be made only by the department of water supply, gas and electricity employees. The cost of the installation shall be borne by the owner of the property for which the connection is made.

(3) DESTRUCTION OF ABANDONED CORPORATIONS STOPS AND WET CONNECTIONS.- All driven corporation stops, when abandoned, shall be removed and replaced by plugs. All wet connections or screw corporation stops, when abandoned, shall be destroyed in place, and all exposed portions of the service pipe shall be cut and removed. Where a corporation stop or wet connection is destroyed and the connecting service pipe is one that is equipped with a curb valve and box, the curb box shall be removed. The expense in connection with the abandonment or destruction of a corporation stop or wet connection shall be chargeable to the owner of the property into which the service pipe entered.

(b) Service.-

(1) SERVICE PIPES, DEFINITION.-See Section P100.0.

(2) SIZE OF TAPS AND WATER SERVICE.-The size of service pipe to supply a premise shall be based upon the water demand load of the premises as determined by "fixture units". "Fixture units" shall conform to the requirements of the department of water supply, gas, and electricity. In premises used for commercial and industrial purposes where it is not feasible to determine the size of the service pipe on the basis of "fixture units," the size of the service pipe shall be based upon the water demand load of the premises. The minimum size service shall be 1 in. in diameter, and the gooseneck shall be the same size as the service pipe.

(3) SIZE OF FIRE LINE SERVICE.-Sizes of connections for fire service shall be subject to the requirements of the department of water supply, gas, and electricity.

(4) SEPARATION OF WATER SERVICE AND BUILDING SEWER.-Except as permitted below, the underground water service and the building sewer shall be at least 10 ft. apart horizontally, and shall be separated by compacted earth. The water service may be placed in the same trench with the building sewer and building drain under the following conditions:

- a. The sewer is of cast iron with leaded or mechanical joints.
- b. The bottom of the water service, at any point, shall be at least 12 in. above the top of the sanitary or combined sewer line.
- c. The water service shall be placed on a continuous shelf of compacted earth, excavated at one side of the common trench.
- d. The water service pipe shall have a minimum number of joints.

(5) WATER SERVICE NEAR SOURCES OF POLLUTION.- Potable water service pipes shall not be located in, under, or above any cesspools, septic tanks, septic tank drainage fields, or seepage pits. A separation of 10 ft. horizontally shall be maintained.

(6) PROTECTIVE COVER FOR SERVICE PIPE.-All

Reference Standard 16

water services shall be installed and maintained at a depth of at least 4 ft. below the finished outside ground surface. Where a service pipe has less than 4 ft. of cover due to subsurface conditions, it shall be insulated and protected as required by the department of water supply, gas, and electricity.

(7) **INSTALLATION OF SERVICE PIPE.**-Each new service pipe shall be laid in a straight line at right angles to the street main and extending from the tap to the main house-control valve. Where the surface or subsurface conditions make it impracticable to install a service pipe in accordance with the above conditions, it may be laid differently provided a sketch or plan showing the proposed alternate location of the service pipe is submitted to and approved by the department of water supply, gas and electricity. The driving of a service pipe through the ground is prohibited.

**** (8) GOOSENECKS ON SERVICE PIPE.**-

Connections to the city main by cast iron or ductile iron pipe may be made directly; no offset swing joint will be required. Each copper tubing service pipe shall have an excess of at least 3 ft. of pipe formed in a gooseneck at the connection to the tap and laid to the right side, facing the tap. Each brass or copper service pipe shall have, at the tap or wet connection, a copper tubing gooseneck of at least 3 ft. of pipe, or an offset swing joint consisting of four elbows and three pieces of pipe each at least 2 ft. in length, laid to the right side, facing the connection.

Where buildings are constructed on pile foundations or other unyielding supports, the service pipes of material other than cast iron or ductile iron shall have two goosenecks, one at the tap and one immediately outside the building. A sleeve shall be installed to carry the service through the foundation wall.

****Local Law 29-1987**

(9) **CURB VALVES.**-Curb valves shall be installed on all fire service pipes. They shall be installed on all domestic service pipes over 2 in. in diameter and at the option of the owner, on service pipes 2 in. or less in diameter. The curb valves and boxes shall be set in the service pipe in the sidewalk area at the curb or within 2 ft. of the curb. Curb valves shall be of the gate type nonrising stem valve, designed for a minimum of 150 psi wwp.

Access to all curb valves installed shall be provided by a tar coated iron extension box with cover, and the cover shall be flush with the sidewalk level. Curb valves 2 in. and less in diameter may be equipped with a wheel for operation, provided a permanent 1/2 in. diameter iron rod is attached thereto and extended to the top of the curb box. No curb valve shall be installed in a driveway. Curb valves larger than 2 in. in diameter shall be equipped with an operating nut at least 1 1/4 in. square and no extension rod need be attached thereto. Such operating nut may be installed on curb valves 2 in. and less in diameter at the option of the owner.

In sprinkler and fire line installations, the location of

the sidewalk control valve shall be governed by the provisions of the building code.

(10) **CLEARANCE.**-Clearance shall be provided around a water service pipe passing through a wall to protect it against the following:

- a. Chemical action from direct contact with concrete.
- b. Distortion or rupture of water service pipe from shearing action due to settlement.
- c. Distortion or rupture of the water service pipe caused by expansion or contraction.

Clearance shall not be less than 1/2 in. between the outside of the pipe and the wall. Sleeves or arches may be used to provide the wall opening. The space between the pipe and the wall structure or the sleeve shall be carefully packed or caulked with lead or waterproof material resistant to vermin and rodents.

(11) **TEST OF SERVICE OF SERVICE PIPE.**-In the presence of the tapper or inspector of the department of water supply, gas, and electricity, each new service pipe or repaired service pipe shall be subjected to a water test made under the street main pressure. All pipes and appurtenances shall remain uncovered for the duration of the test and shall show no sign of leakage. When any question arises as to the installation conforming with these regulations, an internal hydrostatic test as specified for materials may be applied, subject to the approval of the department of water supply, gas, and electricity.

***** (12) HOUSE CONTROL VALVES.**-The house control valve shall be of the gate or full port ball type, and shall be placed in the service pipe inside the building within 2 ft. of the building foundation wall and located so as to be accessible at all times. All valves shall be designed for a minimum of 150 psi and gate valves may be of the outside screw and yoke type.

*****Local Law 10-1999.**

P107.3 Meters.-

(a) Where required.-

(1) **BUILDINGS UNDER CONSTRUCTION.**-All water used in the construction of buildings 75 ft. or six stories or more in height shall be metered. Prior to the commencement of actual building construction, a meter of proper size shall be installed on each tap or service supplying the premises. It shall be placed in an accessible location close to the point of entry of the service pipe, as designed by the department of water supply, gas and electricity. Each meter shall be enclosed in a vault or box capable of providing adequate protection against damage or injury from frost or any other cause. Each meter shall remain in service throughout the entire period of building construction, and thereafter until such time as the annual water charges for the structure becomes effective or the permanent meter has been installed. No permit will be issued for the installation of a meter to register the supply of water used for the construction of a building six stories in height or less. Such water will be charged for as required by the department of water supply, gas, and electricity.

***(2) FIRE LINES.** Combined fire/domestic service for

Reference Standard 16

new sprinkler systems in residential buildings up to six stories or seventy-five feet in height may use one fire-rated compound meter on the combined service or a standard displacement meter on the domestic branch and a detector check valve assembly on the fire branch. If a fire-rated compound meter is used, it shall be certified or listed by the Underwriters Laboratories or The Factory Mutual System or an equivalent national listing organization.

**Reference to Local Law 5-1973 removed by Local Law 10-1999.*

(3) **REFRIGERATION AND AIR CONDITIONING.**-Where the rate of water required for operation of refrigeration and air conditioning apparatus exceeds 1/2 gpm, the building supply shall be metered, as required by the department of water supply, gas, and electricity.

(4) **MISCELLANEOUS FIXTURES.**-The following fixtures or devices shall not be installed or used except where the supply of water to the fixture or devices is metered or connected to a metered distribution system: display fountains containing over 1,000 gal. of water; aquariums containing over 300 gal. of water; irrigation systems; swimming tanks, wading pools, or plunge baths containing more than 5,000 gal. of recirculated water; or hydrotherapy devices requiring the use of city water for their operation.

(b) **Location of meters.**-In all premises where the supply of water is to be fully metered, the meter shall be set within 3 ft. of the building foundation or vault wall at the point of entry service pipe. The service pipe between the house control valve and the meter shall be kept exposed. When a building is situated in back of the street line or when conditions exist in a building that prevent the setting of the meter at a point of entry, the meter may be set outside of the building within the property line, provided the meter is installed in an accessible, watertight, and frost-proof pit or meter box. All meter locations shall be subject to approval by the department of water supply, gas, and electricity.

(c) **Setting of meters.**-In setting or resetting a meter, the requirements are as follows:

(1) The meter shall be set so that the dial faces upward and is horizontal. The dial shall not be more than 3 ft. above the floor.

(2) Connections shall be made by a coupling, union, or flange union on both the inlet and outlet end of the meter and bored for sealing with holes at least 3/32 in. in diameter. Union or couplings that would permit removing the meter setting without breaking the seal wiring are prohibited.

(3) A house valve shall be installed in the service pipe on the inlet side of the meter within 1 ft. of meter except that when a current meter is set, a straight section of pipe with a length of eight times of diameter of the meter inlet size, shall be installed immediately before the inlet between the control valve and the meter with no fittings of any kind installed in the straight section of pipe.

(4) A valve shall be installed on the outlet of all meters of 1 in. size or larger.

(5) A full sized test tee shall be placed on all 1 1/4 in., 1 1/2 in., and 2 in. meters, on the outlet between the meter and the outlet valve, with a short, capped nipple in the tee.

(6) A test tee with a 2 in. opening shall be placed on all meters 3 in. and larger on the outlet between the meter and outlet valve with a short nipple in the tee, and a 2 in. valve shall be placed on the nipple.

(7) All meters not equipped with a test tee and outlet valve shall have a tee with a faucet in it inserted in the line on the outlet side within 2 ft. of the meter, except that this requirement may be waived where other readily accessible means are provided for testing the meter to determine whether the meter is registering correctly.

(8) No connection shall be made to a test tee.

(9) Before setting meters 3 in. and larger, a plan or sketch showing the proposed installation, and indicating the location of service control valve inside of the building, the distance of the meter from the point of entry of service, the height from floor, the size and the type of meter, and the approximate date of setting shall be filed in duplicate with the department of water supply, gas and electricity for approval.

(d) **Size and type of meter.**-

(1) **APPROVED METERS.**-Meters shall conform to standards approved by the department of water supply, gas, and electricity.

(2) **SIZE.**-A meter shall be restricted to a size that will give accurate registration on the basis of consumption and occupancy of the premises or portion of the premises metered. The meter in no case may be more than one standard size larger than the tap or connection to the city main. The piping of the meter setting from the inlet valve to the outlet valve shall be of the same size as the meter. Where inaccuracy of registration is found to be due to the improper size of the meter, such meter shall be replaced with another meter of a size designated by the department of water supply, gas, and electricity.

P107.4 Check Valves.-

(a) A check valve shall be placed in all services where one of the following conditions exist:

(1) Where a building is supplied by services connected to different mains.

(2) Where there is any possibility of backflow from tanks, siamese connections, or other apparatus or fixtures within the building.

(b) Such check valves shall be placed within 2 ft. of the outlet side of the main house-control valve or on the metered connections between the meter test tee and the outlet valve.

P107.5 Water Supply Distribution System.-

(a) **Design, adjustment, and maintenance.**-The water supply distribution system shall be designed and adjusted to supply fixtures and equipment with the amount of potable water required for proper use, cleansing and

Reference Standard 16

performance. Pipe sizing shall be predicated on hydraulic design by an architect or engineer, subject to the approval of the Commissioner.

(b) Minimum pressure.-

- (1) The minimum pressure available near the faucet or water outlet with the water outlet wide open shall be 8 psi.
- (2) At all other equipment and flush valves requiring more than 8 psi, the minimum flow pressure shall be the pressure required for satisfactory performance.
- (3) Where street main pressure fluctuates, the building water distribution system shall be designed for the minimum pressure available.

(c) Inadequate water pressure in street mains.-

Whenever water pressure from the street main or other source of supply is insufficient to provide pressures at fixture outlets, an auxiliary supply shall be provided in

accordance with Section P107.7.

(d) Maximum pressures.-Where the static or street main pressure exceeds 85 psi on fixtures, a pressure reducing valve shall be installed to reduce the pressure to 85 psi or less at the fixture with no flow and the fixture closed. Sillcocks and outside hydrants may be left at full pressure.

(e) Minimum size of water supply branches and risers.-

(1) The minimum size of an individual branch supply to a fixture shall be predicated on supplying the flow of water listed in Table RS 16-7 at velocities not in excess of 8 fps.

(2) The branches, risers, and headers shall be sized to produce velocities not in excess of 8 fps for the flow predicated on the probable demand of flow in the branch, riser, or header pipe.

TABLE RS 16-7 MINIMUM RATE OF FLOW AND MINIMUM REQUIRED PRESSURE DURING FLOW FOR SIZING INDIVIDUAL BRANCH SUPPLIES FOR PLUMBING FIXTURES

| Location | Flow Pressure ^a (psi) | Flow Rate ^b (gpm) |
|------------------------------------|-------------------------------------|---------------------------------|
| Ordinary basin faucet | 8 | 2.0 |
| Self-closing basin faucet..... | 8 | 2.5 |
| Sink faucet, 3/8 in. | 8 | 4.5 |
| Sink faucet, 1/2 in. | 8 | 4.5 |
| Bathtub | 8 | 5.0 |
| Laundry tub cock, 1/2 in. | 8 | 5.0 |
| Shower | 8 | 5.0 |
| Ball-cock for closet | 8 | 3.0 |
| Flushometer valve for closet | 10-20 | 15-40 ^c |
| Flushometer valve for urinal | 10 | 15.0 |
| Drinking fountains | — | 0.75 |

Notes-

^a The flow pressure is the pressure in the supply pipe, near the faucet or water outlet while the faucet or water outlet is wide open and flowing.

^b At fixtures supplied with both hot and cold water, the flow rate indicated is for each of the two connections.

^c The wide range is due to the variation in designs and types of water closet flush valves and water closets.

(f) Water hammer.-All building water supply systems shall be provided with devices to absorb shocks resulting from high pressure caused by the quick closing of valves. These pressure absorbing devices shall be either air chambers or mechanical devices. Water pressure shock absorbers may be installed at the end of long pipe runs or near batteries of fixtures.

(1) Air chambers installed on the main service shall be in an accessible place, and each air chamber shall be provided with a means for restoring the air should the chamber become waterlogged.

(2) Air chambers installed at individual fixtures need not be accessible. Air chambers for fixtures shall be at least 12 in. long and of the same diameter as the branch pipe connection; for quick closing valves the chamber shall be at least 18 in. long. One air chamber may service a battery of fixtures provided the single air chamber is at least 24 in. long and is at least the size of the supply branch.

(3) Mechanical devices shall be used in accordance with the manufacturers' specifications as to location and method of installation.

P107.6 Water Supply Control Valves.-

(a) Stop-and-waste valves prohibited.-Combination stop-and-waste valves or cocks shall not be installed in underground or buried water supply piping.

(b) Riser valves.-Except in a one-family dwelling, a valve shall be installed at the foot of each water supply riser. In multistory buildings, a valve shall be installed at the top of each water supply down-feed pipe.

(c) Valves in dwelling units.-In two-family dwellings and in dwelling units of buildings classified in occupancy group J-2, control valves on the supply branch or stop valves on each individual fixture shall be provided so that the water to any dwelling unit may be shut off without stopping the flow of water to other units.

(d) Individual fixture valves.-In buildings of occupancy other than those in (c) above, the supply branch to the group of fixtures or the supply branch to each fixture or piece of equipment shall be provided with a valve or a fixture stop valve to shut off the water to the fixture or to the room in which it is located.

(e) Tank controls.-Supply lines to and from pressure

Reference Standard 16

or gravity tanks shall be supplied with valves at the tanks within the tank room.

(f) Water heating equipment valve.-The cold water branch to each hot water storage tank or water heater shall be provided with a valve located near the equipment. Each tank or heater shall be equipped with an approved automatic relief valve as prescribed in Section P107.26.

(g) Accessibility.-All water supply control valves shall be placed so as to be readily accessible for service and maintenance.

(h) Control valve design.-Except the valves serving single fixtures, control valves on all water lines shall, when fully opened, have a cross-sectional area of at least 85 percent of the cross-sectional area of the line in which they are installed.

(i) Bath and shower valves.-Valves for individual showers or bathtubs, or multiple gang showers shall be balanced pressure-mixing valves, or thermostatic mixing valves, or combination pressure balancing/thermostatic valves, conforming to the requirements of ASSE 1016 (December 1988). Water temperature control valves shall be equipped with high-limit stops adjusted to a maximum hot water setting of 120 degrees Fahrenheit (49 degrees Celsius).

**Local Law 86-1996*

(a) When required.-When the pressure in the street water main or individual water supply system is insufficient to supply the probable peak demand flow to all plumbing fixtures and other water needs freely and continuously, and with the minimum pressures and quantities as prescribed in Section P107.5, or elsewhere herein, the rate of supply shall be supplemented by one of the following:

- (1) An elevated gravity water supply tank.
- (2) A hydropneumatic pressure booster system.
- (3) A water pressure booster pump system.
- (4) A combination of these systems.
- (5) Other systems designed by an architect or engineer, subject to the approval of the commissioner.

P107.8 Water Supply Tanks.-

(a) Overflows.-Each gravity or suction water supply tank shall be provided with an overflow not smaller than shown in Table RS 16-8 and/or RS 16-9. The gallons per minute listed in the tables shall be the total automatic pump capacity connected to the tank, or the calculated carrying capacity of the fill pipe. The overflow outlet shall discharge within 6 in. of a roof or roof drain, or over an open water supplied fixture. The overflow discharge shall be provided with durable screening with openings of not more than 1/8 in.

P107.7 Auxiliary Water Systems.-

**TABLE RS 16-8 SIZE OF OVERFLOWS FOR GRAVITY AND SUCTION TANKS
(See Figures RS 16-1 A and B)**

| Overflow Pipe Size (in.) | Maximum Allowable gpm for each Orifice Opening into Tank | Maximum Allowable gpm for Vertical Overflow (Piping Connecting Orifices) |
|-----------------------------|--|--|
| 2 | 19 | 25 |
| 3 | 43 | 75 |
| 4 | 90 | 163 |
| 5 | 159 | 296 |
| 6 | 257 | 472 |
| 8 | 505 | 1,020 |
| 10 | 890 | 1,870 |
| 12 | 1,400 | 2,967 |

**TABLE RS 16-9 SIZE OF WEIRS FOR GRAVITY AND SUCTION TANKS
(See Figure RS 16-1C)**

| Slotted Weir Opening into Tank between Overflow Chamber and Water Compartment ^a | Maximum gpm Allowable for Weir |
|--|-----------------------------------|
| 3 in. x 24 in. | 381 |
| 3 1/2 in. x 24 in. | 475 |
| 4 1/2 in. x 24 in. | 685 |
| 4 1/2 in. x 36 in. | 1,037 |
| 6 in. x 36 in. | 1,569 |
| 6 in. x 48 in. | 2,100 |

Note-

^a Bottom of the overflow chamber must be at least 6 in. below weir.

Bottom outlet shall be provided in the chamber of sizes based on capacities as indicated in table RS 16-8.

Reference Standard 16

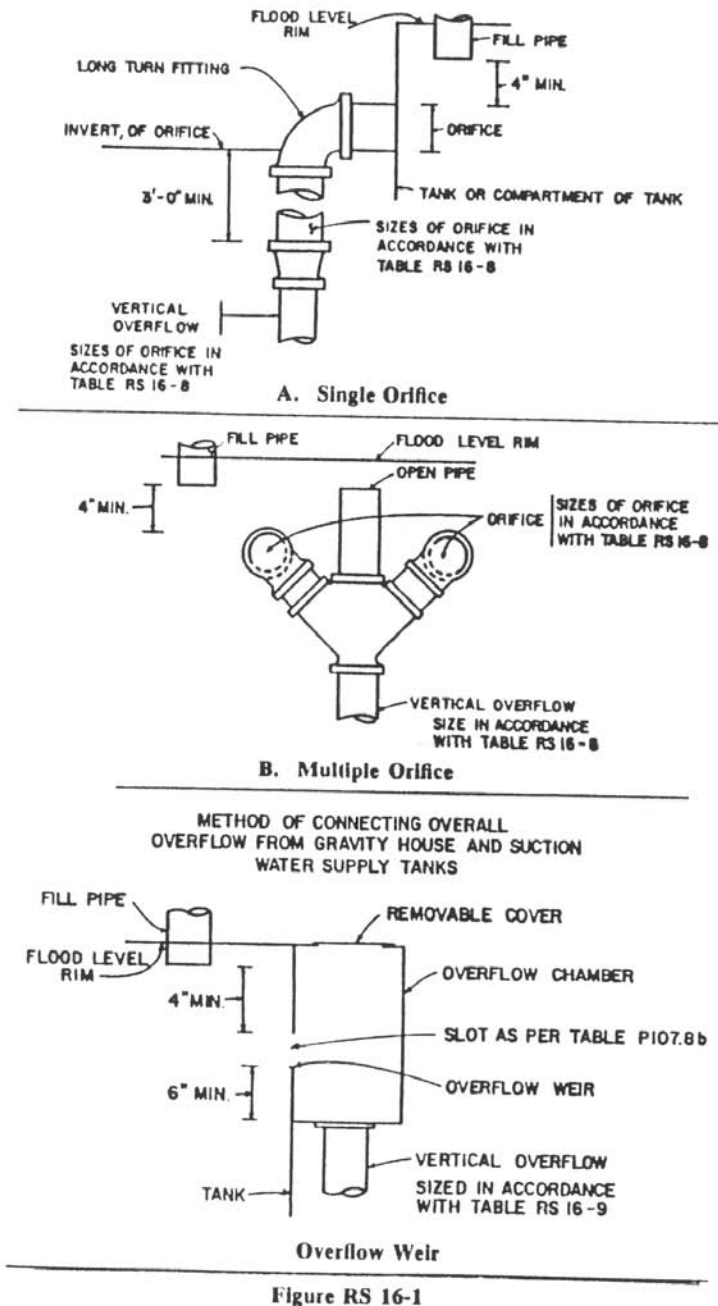

Figure RS 16-1

(b) Water piping control and location.-Water inlets to gravity house tanks shall be controlled by a ball cock or other automatic supply valve or emergency electrical cut-off so installed as to prevent the overflow of the tank in the event that the pumps filling the tanks do not shut off at the predetermined level or the street pressure rises to a point where it can fill the tank. The water inlet to a suction tank shall be controlled by a ball cock or other automatic supply valve. The inlet shall be terminated so as to provide an accepted air gap but in no case shall it be less than 4 in. above the top of the overflow. The outlet from a gravity tank to the distribution system shall be equipped with a strainer located at least 2 in.

above the tank bottom to prevent solids from entering the piping system. All down-feed supplies from a tank cross-connected in any manner with distribution supply piping in a building supplied by direct street or pump pressure, shall be equipped with a check valve on the main cold water down supply to prevent backflow of water into the roof tank.

(c) Drain pipes for emptying tanks.-Each tank or tank compartment shall be provided, at its lowest point, with a valved pipe to permit emptying the tank. The drain pipe shall discharge as required for the overflow pipe, and shall be at least 4 in. in diameter.

(d) Prohibited location.-Potable water gravity tanks or manholes of potable water pressure tanks shall not be located directly under any soil or waste piping.

(e) Design.-The gravity house supply tank shall be built of wood, steel, or equivalent materials. Subject to the approval of the Commissioner, additional linings may be installed in the tank, provided the lining material does not have a toxic or otherwise objectionable effect on the potable water. Steel tanks shall be painted both inside and outside. If a tank with a dividing partition is installed, the total capacity of the combined compartments shall be considered as the capacity of a single tank for the purpose of determining storage capacities of the tank.

(f) Hydropneumatic pressure booster tanks.-Pressure tanks shall be cylindrical and shall be built in accordance with the ASME Boiler Code, 1967, Section VIII. The tank shall be galvanized or painted both inside and outside unless it is constructed of a nonferrous material. The tank shall be provided with a pressure relief valve. Also, it shall be provided with a vacuum relief if the tank is located and installed so that it can be drained by a fixture located below the tank. The air supplied to the tank shall be filtered and taken from an area that does not impart any toxicity to potable water stored in the tank.

(g) Cleaning or painting.-

(1) No water tank of any kind that is part of a building water supply system used for potable purposes shall be cleaned with any material or painted on the inside with any material that will have a toxic or otherwise objectionable effect on the potability of the water supply when the tank is put into service. No lead paint shall be used. The water supply connections to and from a tank shall be disconnected or plugged while the tank is being cleaned or painted to prevent any foreign fluid or substance from entering the distribution piping. Where the air in a tank may be insufficient to sustain human life, or may contain an injurious gas, adequate measures shall be taken for the protection of the workmen.

(2) After the tank has been cleaned or painted, it shall be disinfected according to the following procedure before it is put back in service:

- The underside of the top, the bottom, and the walls shall be washed with a hypochlorite solution containing 100 or more parts per million of available chlorine.
- The tank shall be filled with water to which hypochlorite solution is added during the filling in sufficient quantity

Reference Standard 16

so that the treated water in the tank will contain at least 10 parts per million of available chlorine.

c. The chlorinated water shall be allowed to remain in the tank for two hours.

d. Finally, the tank shall be drained completely before refilling.

(3) House and suction tanks shall be drained and cleaned at least once a year.

(h) Supports.-All water supply tanks shall be supported in accordance with the requirements for structural work of the building code.

(i) Covers.-All water supply tanks shall be covered to keep out dirt, vermin, and unauthorized persons.

P107.9 House and Booster Pumps.-

(a) Directly off street main.-Power pumps may draw their water supply directly from the street main if the total connected automatic pump capacity is not more than 400 gpm. If the total connected automatic capacity exceeds 400 gpm, the pumps may be connected directly to the street main only if permitted by the department of water supply, gas, and electricity.

(b) Suction tank.-

(1) When the pumps cannot be connected directly to the water service main a suction (surge) tank shall be installed. Suction tanks shall be constructed in accordance with the requirements of Section P107.8.

(2) No suction tank will be required for a fire pump except where the size of the fire service is equal to or greater than the size of the street main.

(c) Suction tank size.-Suction tanks when required, shall have a capacity not less than prescribed in Table RS 16-10.

TABLE RS 16-10 SUCTION TANK SIZES

| Total Connected Pump Capacity (gpm) | Tank Capacity (gal.) |
|-------------------------------------|----------------------|
| 400-500 | (7,500) |
| 501 and over | (10,000) |

(d) Fill line to tank.-A fill connection to a suction tank shall be provided with a flow control that will limit the water make-up rate to the suction tank under the pressure conditions and at the maximum quantities permitted by the department of water supply, gas, and electricity.

(e) Low pressure cut-off required on booster pumps.-When a pump is directly connected to the street main, a low pressure cut-off shall be installed on the house side of each building control valve and on the street side of each meter assembly to prevent the pressure from dropping more than 7 psi below the normal static pressure at the point of entry of the water service, or as required by the department of water supply, gas, and electricity.

(f) Check valves required.-Each pump discharge shall be provided with a check valve and gate valve.

P107.10 Protection of Potable Supply.-

(a) General.-A potable water supply system shall be

designed, installed, and maintained in such manner as to prevent contamination from non-potable liquids, solids, or gases from being introduced into the potable water supply through cross-connections or any other piping connections to the system.

(b) Identification of potable and non-potable water.-In all buildings having dual water distribution systems, one potable water and the other non-potable water, each system shall be identified either by color marking or metal tags.

(c) Color marking.-When color marking is used, potable water lines shall be painted green and non-potable water lines shall be painted yellow. This requirement may be met by painting 3 in. wide bands, green or yellow, at intervals of not more than 25 ft. and at points where piping passes through walls, floors, or roofs, in which case the bands shall be applied to the piping on both sides of the walls and both above and below the floor or roof. Points of outlets for nonpotable water shall be marked with a tag or color code.

(d) Metal tags.-When tags are used, potable water lines shall be identified by 3 in. diameter metal tags bearing the legend "SAFE WATER" in letters at least 1/2 in. high. Non-potable water lines shall be identified by firmly attached metal tags having the shape of a 4 in. equilateral triangle bearing the legend "WATER UNSAFE" in letters at least 1/2 in. high. As in the use of color bands, tags shall be attached to pipes at intervals of not more than 25 ft. and at both sides at points where pipes pass through walls, and both above and below points where pipes pass through floors or roofs.

P107.11 Toxic Materials and Substances.-No materials or substances that could produce either toxic conditions or add taste or odor to a potable water system shall be introduced into or used in such systems.

P107.12 Used Piping.-Piping that has been used for any purpose other than conveying water shall not be used for conveying potable water.

***P107.13 Prohibited Connections To Fixtures And Equipment.**-The following equipment shall receive water supply only through air gaps and direct water connections to the potable water supply system shall be prohibited unless a reduced pressure principle back pressure backflow preventer is installed between the water supply and the equipment.

- (1) Bidets with submerged water connection that cannot drain out after shut off.
- (2) Aspirators, injectors, ejectors or water siphons and similar apparatus.
- (3) Mortuary, dissection, operating and embalming tables or similar equipment.
- (4) Sterilizers.
- (5) Flushing rim floor drains.

**Local Law 69-1977*

P107.14 Connections to Mechanical Equipment and Systems.-Potable water connections to boiler feed water systems and heating or cooling systems shall be

Reference Standard 16

made through a fixed air gap. Where the equipment or system is fed through an injector the potable water shall be supplied through a fixed air gap to the suction tank of a booster pump.

P107.15 Refrigeration Unit Condensers and Cooling Jackets.-Where potable water is provided for a refrigerator condenser or cooling jacket the connection must be entirely outside of the piping or tank containing the toxic refrigerant shall be used. The inlet connection shall be provided with check valve and, if the refrigeration units contain more than 20 lbs. of refrigerant, with an approved pressure relief valve set to relieve at 5 psi above the maximum water pressure at the point of installation, adjacent to and at the outlet side of the check valve.

P107.16 Air Conditioning and Refrigeration.-

- (1) Each direct water connection to a refrigeration or air conditioning unit using city water for cooling purposes shall be equipped with a check valve located not more than 2 ft. from the unit.
- (2) Where the refrigeration or air conditioning system in a building is in excess of 1/3 ton, the city water supply to such building shall be metered.
- (3) Where the refrigeration or air conditioning unit using city water is 1/3 ton or less, and the unit is located in a metered premise, the unit shall be connected to the metered supply.
- (4) All systems of refrigeration in excess of 6 tons and/or air conditioning in excess of 3 tons shall be equipped with a water conserving device. Ice cubers and ice flakers shall be exempted from this requirement. The tonnage shall be the combined or total tonnages for all water cooled refrigeration systems for air conditioning or any other purpose installed in any one building.
- (5) In buildings where the tonnage is less than the tonnage specified in (4) above, an approved automatic regulating device shall be installed at each refrigeration unit.
- (6) Where city water is supplied to a water conserving device, other than a combination air and water cooled condenser, the piping supplying such water shall discharge at least 2 in. above the overflow rim of the pan.
- (7) The waste water from all systems having direct connection to the city water supply shall be discharged (outlet of the discharge piping) shall be located at least 1 in. above the overflow rim of said receptacle.
- (8) "Automatic water regulating valve or device" shall mean a self-regulating valve or other device that shall limit the use of city water to 1.5 gpm or less per ton of refrigeration or air conditioning.
- (9) "Water conserving device" shall mean an evaporative condenser, water cooling tower, spray pond, economizer, or similar apparatus that shall not consume city water for make-up purpose in excess of 2 percent of the amount that would normally be used without such device. In addition, 3 percent of the amount of water that would normally be used without such device shall be allowed for purpose of bleeding and wash down.

P107.17 Used Water Return Prohibited.-

Water used for cooling of equipment or other processes shall not be returned to the potable water system. Such water shall be discharged into the drainage system through an air break to a receptacle or fixture.

***P107.18 Protection Against Backflow and Back-Siphonage.**-Unless otherwise provided in this code, protection of the potable water system against backflow and back-siphonage shall be by providing, installing, and maintaining at each outlet one of the following:

- (1) Air Gap: In accordance with ANSI A112.1.2-1942 (R1973).
- (2) Vacuum Breaker: In accordance with ANSI A112.1.1-1971 (ASSE No. 1001-1970).
- (3) Reduced Pressure Principle Back Pressure Backflow Preventer: In accordance with ASSE No. 1013-1974.
- (4) Double Check Valve-Type Back Pressure Backflow Preventer: In accordance with ASSE No. 1015-1972.
- (5) Backflow Preventer With Intermediate Atmospheric Vent: In accordance with ASSE No. 1012-1972.

Vacuum breaking and backflow preventing devices shall be accessibly located, preferably in the same room with the fixture they serve. Installation of vacuum breaking devices in utility or service spaces is also permitted, provided the devices are readily accessible.

**Local Law 69-1977.*

***As enacted but "1970" probably intended .*

P107.19 Approval of Devices.-Before any device for the prevention of backflow or back-siphonage is installed, it shall have first been tested and a test report showing compliance with the applicable standard shall have been filed by an architect or engineer, in accordance with the administrative provisions of the building code.

P107.20 Protection of Potable Water Supply Outlets.-

- (a) Backflow preventers or vacuum breakers shall be installed with any plumbing fixture or equipment in each potable water supply outlet that may be submerged and that cannot be protected by a minimum air gap, or as otherwise provided in this code. All submerged inlets, except for connections to water closet and urinal flushometer valves and ball floats for tank water closets and urinals, shall have a check valve installed between the vacuum breaker and the submerged inlet.

(b) Type required.-

(1) CONNECTIONS NOT SUBJECT TO BACK PRESSURE.-

Where a water connection is not subject to back pressure, a non-pressure type vacuum breaker shall be installed on the discharge side of the last valve on the line serving the fixture or equipment. A partial list of conditions requiring protective devices of this kind is given in Table RS 16-11. The critical level shall be indicated on the vacuum breaker, or in the event the critical level is not indicated, the lower end of the vacuum breaker body shall constitute the critical level.

(2) CONNECTIONS SUBJECT TO BACK PRESSURE.-

Where a potable water connection is made to a line, fixture, tank, vat, pump, or other equipment with a hazard of backflow or back-siphonage where the water connection is subject to back pressure, a pressure type vacuum breaker and check valve shall be installed.

Reference Standard 16

TABLE RS 16-11 CROSS-CONNECTIONS WHERE PROTECTIVE DEVICES ARE REQUIRED AND CRITICAL LEVEL (C-L) SETTING FOR VACUUM BREAKERS

| Fixture or Equipment | Methods of Installation |
|---|--|
| Dental Units | On models without built-in vacuum breakers - C-L at least 4 in. above flood rim of bowl. |
| Dishwashing machines | An air gap or with the C-L at least 4 in. above flood level of machine. Install on both hot and cold water supply line and on water supply to detergent or water softening appliances. |
| Flushometers (closet and urinal) | C-L at least 4 in. above top of fixture supplied. |
| Garbage can cleaning machine | C-L at least 4 in. above flood level of machine. Install on both hot and cold water supply lines. |
| Hose outlets, (except outside sillcocks, draincocks at base of water risers or at equipment, and fire hose outlets) | C-L at least 4 in. above highest point on hose line or as permitted by the commissioner. |
| Laundry machines | C-L at least 4 in. above flood level of machine. Install on both hot and cold water supply lines. |
| Lawn sprinklers | C-L at least 12 in. above highest sprinkler or discharge outlet. Installed on header at building wall. |
| Steam tables | C-L at least 4 in. above floor level. |
| Tanks and vats | C-L at least 6 in. above flood level rim or line. |
| Trough urinals | C-L at least 30 in. above perforated flush pipe. |
| Flush tanks | All flush tanks operated by ballcocks shall have a vacuum breaker located not less than 1 in. above the overflow outlet of the flush tank. |

P107.21 Preheating Apparatus.-Water supply lines to water preheating apparatus utilizing waste water from the plumbing system shall be equipped with a vacuum breaker located at least 4 in. above the highest elevation of the preheating apparatus or coil, with a check valve between the vacuum breaker and the preheating apparatus. Any hot water boiler supplied through such preheating device and having an independent cold water supply line shall have the cold water supply line equipped with a vacuum breaker and check valve located at least 4 in. above the highest elevation of the boiler.

P107.23 Chemical Solution Tanks or Apparatus.-Direct water supply connections to any tank or apparatus containing any chemical shall be prohibited unless specifically approved by the department of health.

P107.24 Bedpan Washers.-Bedpan washers or similar apparatus not provided with an approved flushometer shall be equipped with a vacuum breaker and check valve. The check valve shall be located between the fixture and the vacuum breaker. Water supply to bedpan washers equipped with an approved flushometer valve shall be provided with a vacuum breaker. Bedpan washers may be equipped with steam connections only when such equipment has been approved.

P107.25 Laboratory Outlets.-Each laboratory outlet provided with a serrated tip or hose end shall be provided with a vacuum breaker.

***P107.26 Hot Water Supply System.**
(a) Return circulation-where required.

(1) Hot water supply systems, in buildings four stories or more in height, or buildings in which the developed length of hot water piping from the source of hot water supply to the farthest fixture supplied exceeds 50 ft. shall be of the return circulation type, except as otherwise provided in subparagraph (2) of this paragraph. No branch from a noncirculated riser or header shall exceed 50 ft.

(2) A temperature maintenance system with electric heaters and components applied to the domestic hot water piping may be used in lieu of a return circulation system provided:

a. The system conforms to the requirements of national standard ANSI/IEEE 515-1983.

b. The minimum predetermined temperature in the domestic hot water piping is not less than 100°F.

c. The minimum outlet temperature of the hot water supply source is not less than 110°F.

d. All heating cable cores are permanently marked with the manufacturer's batch or serial number for traceability and cable jackets are continuously and permanently marked with manufacturer's name, catalog number, nominal supply voltage and nominal power output in watts per ft. The use of temporary printing or tags shall not be permitted.

e. Test certificates accompany each reel of heating cable and are signed by the manufacturer's quality control officer. The certificates shall indicate the cable type, cable rating in watts per ft., voltage rating, test date, batch number, reel number, length of cable, test voltage and test amperage reading.

f. The system is listed for domestic hot water piping by an accepted nationally recognized independent laboratory that maintains periodic inspections of production of listed equipment and whose listing states that the

Reference Standard 16

equipment meets nationally recognized standards for domestic hot water piping.

g. The system is accepted and approved by the department of buildings.

(b) Pressure relief valves, temperature relief valves and energy cutoff devices required.-Equipment used for heating water or storing hot water shall be provided with one of the following safety devices:

A separate pressure relief valve and separate temperature relief valve.

A combination pressure and temperature relief valve.

(1) No check valve or shut-off valve shall be installed between the safety device and the hot water equipment used.

(2) Relief outlets or relief valves shall not be directly connected to drainage or vent piping.

(3) Relief valve discharge pipes shall be the same size as valve discharge connections and shall pitch downward from the valve to the point of disposal. Pipe shall terminate with an unthreaded end.

(4) Where a relief outlet discharges into a plumbing fixture, a minimum air break shall be provided.

(5) All relief valves and safety devices shall comply with the requirements of the applicable standards of the U.S.A. Standards Institute, American Society of Mechanical Engineers, or the Underwriters' Laboratories. Valves or devices shall be accepted for use in accordance with the administrative provisions of the building code.

(6) All new installations of equipment used for heating water or storing water shall comply with the provisions of subdivision P107.26 of Section P107.0 of Reference Standard RS-16.

(7) All replacements of equipment used for heating water or storing water shall comply with the provisions of subdivision P107.26 of Section P107.0 of Reference Standard RS-16.

(8) All existing equipment used for heating water or storing water shall comply with the provisions of paragraph (b) of subdivision P107.26 of Section P107.0 of Reference Standard RS-16.

(c) Pressure relief valves.-Pressure relief valves and the pressure relief element of combined pressure and temperature relief valves shall be in accordance with the requirements of the ASME boiler and pressure vessel code, 1962, Section IV and the construction requirements of USASI Z21.22-1964.

(1) Valve capacity, as rated from actual test data, shall be at least equal to the rated capacity of the connected heater or heaters.

(2) The opening pressure of the pressure relief valve shall be at least 25 lbs. above the normal working pressure in the system or the pressure delivered by the water pressure reducing valve. In no case shall the relief valve be set to open at a pressure above the rated working pressure of the vessel that the valve is installed to protect.

(d) Temperature relief valves.-Temperature relief valves shall have a relief rating, expressed in Btu per hour, equal to that of the equipment served. They shall be installed so that the temperature sensing element is immersed in the hottest water, such as:

(1) Within the top 6 in. of the tank of an unfired hot water storage heater;

(2) Above the hot water inlet to a tank equipped with a sidearm type water heater or supplied with hot water from another source;

(3) Above the topmost heating element of an electric water heater;

(4) Where, due to the construction of the water heater, there is no tapping to receive the temperature relief valve, the valve shall be installed in a tee following a nipple installed in the heater. The tee shall be located as close as possible to the heater jacket.

(e) Emergency energy cut-off devices.-The performance rating of emergency energy cut-off devices shall be equal to or greater than the performance rating for the equipment served. Immersion type energy cut-off devices shall be installed so that the temperature sensing element is immersed in the hottest water zone of the equipment served. Contact types shall be installed only when permitted by the Commissioner, and shall be rigidly mounted in contact with the shell of the water heater, shall be calibrated accurately for use on the heater to which it is applied, and shall be insulated or protected from flue gas, heat, or other ambient conditions that are not indicative of stored water temperature. Safety pilots or other approved devices shall be installed to cut off the main fuel supply to the main burner or heat producing equipment.

(f) Vacuum relief valves.-All copper lined tanks located and installed so that they can be drained by a fixture located below the tank shall be equipped with a vacuum relief valve that shall comply with USASI Z21.22-1964.

(g) Pressure marking of hot water storage tank.-Hot water storage tanks shall be permanently marked in a readily accessible place to indicate the maximum allowable working pressure, which shall be not more than 2/3 of the bursting pressure of the tank.

(h) Temperature limit controls.-All hot water heaters and storage tanks shall be equipped with an operating temperature limit control.

***** (i) Prohibited locations and usage of hot water generators.**

No solid or liquid fuel or gas fuel-fired water heater shall be installed in bathrooms, bedrooms, or in any enclosed space with a volume of less than 300 cu. ft.; nor shall vents designed only for use with gas equipment be used with solid or liquid fuel-fired equipment. Notwithstanding the foregoing, a gas fuel-fired water heater may be installed in any dwelling unit in accordance with the following conditions:

(1) The enclosed space shall have a minimum volume of at least 100 cu. ft.;

(2) The maximum BTU rating shall be 75,000 BTU/hr.;

(3) There shall be a fresh air intake which shall equal at least one sq. inch free area per 2000 BTU/hr. input rating which in no event shall be less in cross-section than the flue projecting from the hot water heater and which shall be fire damper protected if used for air supply duct work of two or more stories;

(4) The exhaust from the water heater shall be connected to an approved type flue;

(5) The installation shall be made within a solid

Reference Standard 16

enclosure with a flush door without louvres, and with clearances about the water heater conforming to A.G.A. requirements, and

(6) The heater shall be (i) currently listed by an independent laboratory acceptable to the commissioner pursuant to section C26-106.2, (ii) approved by the department and (iii) approved by the department of health.

**Local Law 82-1986; Local Law 67-1977*

****Local Law 45-1984*

P107.27 Disinfection of Potable Water Systems.-

(a) New or repaired potable water systems shall be disinfected prior to use whenever samples from the system show any contamination after making a bacteriological examination. Samples shall be taken as required by the department of health. The method to be followed shall be that as prescribed by the department of health, or where no method is prescribed by the department of health, by the following:

(1) The pipe system shall be flushed with clean, potable water until no dirty water appears at the outlets.

(2) The system or part thereof shall be filled with a water-chlorine solution containing at least 50 parts per million of chlorine and the system or part thereof shall be valved off and allowed to stand for 24 hr. or, the system or part thereof shall be filled with a water-chlorine solution containing at least 200 parts per million of chlorine and allowed to stand for 3 hr.

(3) Following the prescribed standing time, the system shall be flushed with clean potable water until no excess chlorine remains in the water coming from the system.

(4) The procedure shall be repeated if it is shown that contamination still persists in the system.

Section P108.0 Sanitary Drainage Piping

P108.1 Permits.-

(a) Permits for the installation of a building house storm sewer from the street line to and including the spur connection at the street sewer shall be obtained in accordance with the requirements of the building code.

P108.2 Street Sewer Connections.-

(a) Any connection to a sewer, other than a pipe sewer, shall in no case have its inner top lower than 6 in. below the inner top of the sewer.

(b) All building sewer connections to a street arch or circular sewer shall be at a point 45 degrees to the horizontal plane in the upper quadrant of the street arch or circular sewer except as otherwise directed by the department of public works.

******(c) All building house sewer connections shall be made in the presence of an employee of the department.

(d) All building sewer connections shall be flush with the inside face of the wall of the street sewer.

(e) No building sewer connections shall be made to catch basins or drain inlets.

***Local Law 65-1996*

P108.3 Abandonment of Existing Building Sewer Connections.-

(a) All abandoned building sewers shall be securely sealed at a point inside the curb line and as close thereto as practicable.

P108.4 Building (House) Traps.-

(a) Building (house) traps shall be installed as prescribed in Section P105.0.

(b) A building (house) trap shall not be required on a sub-house drainage system that discharges into a sewer ejector pit or sump pit.

P108.5 Fresh Air Inlets.-Every sanitary or combined building (house) drain equipped with a building (house) trap, sewage pump, ejector, receiving tank, oil separator, or similar equipment, shall be provided with a fresh air inlet pipe connected to the building house drain immediately upstream from, and within 4 ft. of, such trap or equipment. Such connection shall be made in the same manner as prescribed herein for vent connections to horizontal drains, and the fresh air inlet pipe shall be extended to the outer air and shall be terminated in an open end at least 6 in. above grade. The open end shall be protected by a perforated metal plate permanently fixed in the mouth of the inlet and having an open ventilating area at least equal to the area of the pipe, or by a return bend with its unprotected open end at least 6 in. above grade located inside the street line. The size of the fresh air inlet pipe shall be at least 1/2 the diameter of the building drain at the point of connection, but not less than 3 in.

P108.6 Drainage Below Sewer Level.-

(a) Drainage from parts of the drainage system that cannot drain into the gravity system or, where the plumbing design does not indicate drainage into the gravity system, shall be disposed of through sub-building (sub-house) drainage systems. The discharge from the ejector or sump pit shall be through a connection located on the street side of the building house trap. The discharge from non-vented, clear water sumps may be connected to any point in the gravity drainage system.

(b) Drainage and vent piping of sanitary building sub-house drainage systems shall be installed in the same manner as for gravity systems. The vents of the building sub-house drainage system may be connected to the vents of the gravity drainage system provided such connection is made above the overflow rim of the lowest fixture on the gravity system.

(c) Sump pits or receiving tanks receiving the discharge from the sanitary drainage or from the building sub-house sanitary drainage system shall be airtight and provided with a vent. Sump pits or receiving tanks that do not receive the discharge of domestic sewage, but receive only clear water from floor drains or machinery drips, need not be air-tight and vented.

(d) Each sewer receiving tank or pit shall be provided

Reference Standard 16

with a vent that is sized on the basis of one fixture unit for each gpm flow of the discharge pumps and the developed length of the vent from the receiver to the vent stack or the outside air, in accordance with Table RS 16-14. The vent from a receiving tank may be connected to the gravity drainage vent system provided such system is 3 in. or larger.

(e) The relief devices of a pneumatic sewage ejector system shall be connected to an independent relief line vent at least 3 in. in diameter. Such vent shall be carried independently through a roof and shall terminate as required for sanitary vent stacks or stack vents. The mechanism for the relief of the air pressure in the closed sewage receptacle shall have valves, piping, and connection that form a part of the sewage ejector device. The devices shall be sufficient in size to relieve the ejector pit to atmospheric pressure in not more than 10 sec., and the minimum size of such valves and piping shall be 1 1/4 in.

(f) Sump pits or receiving tanks may be constructed of concrete provided the compartment is fully waterproofed and the walls of the pit troweled to a smooth finish.

(g) Each sewage ejector or sump discharge shall be provided with a check valve and a gate valve.

P108.7 Sub-Soil Drainage.-Where sub-soil drainage is to be discharged to a public sewer, the sub-soil drains shall discharge into a readily accessible silt and sand interceptor designed by an architect or engineer, the drainage from which shall be disposed of into the gravity drainage system or a sump system. Where the piping from the interceptor is directly connected to the gravity drainage system, such piping shall be provided with an approved and readily accessible backwater valve and shall be connected upstream of a leader or area drain trap. Area drains may be connected to the sub-soil drainage system subject to the provisions of Section P110.2.

P108.8 Drainage Piping Installation.-

(a) **Pitch of horizontal drainage piping.**-Horizontal drainage piping shall be installed in uniform alignment at uniform slopes as follows:

| Size of Piping | Minimum Slope |
|----------------|-----------------|
| 2 in. or less | 1/4 in. per ft. |
| Over 2 in. | 1/8 in. per ft. |

(b) Change of direction.-

(1) Changes in direction in drainage piping shall be made by the appropriate use of 45 degrees wyees; long sweeps; short sweeps, quarter, sixth, eighth, or sixteenth

bends; or by a combination of these or equivalent fittings.

(2) Sanitary tees and quarter bends may be used in drainage lines only where the direction of flow is from the horizontal to the vertical.

(3) Short sweeps will be permitted in drainage piping 3 in. in diameter or larger for any offsets either horizontal or vertical.

(c) Prohibited fittings and connections.-

(1) No running threads, bands, or saddles shall be used in drainage or vent piping. No drainage or vent pipes shall be drilled or tapped.

(2) No fitting, connection, device, or method of installation that retards the flow of water, wastes, sewage, or air in the drainage or vent systems to an extent greater than the normal frictional resistance to flow shall be installed. Double hubs are prohibited for use in drainage piping. No fitting having a hub faced downstream shall be used as a drainage fitting. No tee branch of a drainage fitting shall be used as an inlet branch for wastes. Double sanitary tees may not be used for a fixture connection when a blowout type fixture is connected to one of the inlets.

(3) A heel- or side-inlet quarter bend shall not be used as a vent connection fitting in drainage piping when the heel- or side-inlet is placed in a horizontal position.

(4) The expanding or swedging of 3 in. lead bends or stubs to 4 in. size, thereby causing a reduction in pipe wall thickness, is prohibited. Approved 3 in. x 4 in. lead bends and stubs with uniformly proper wall thickness may be used for connections to 4 in. floor flanges, and 4 in. x 3 in. floor flanges may be used for connection to 3 in. lead bends and stubs.

(d) Dead ends.-In the installation of removal or any part of a drainage or vent system, dead ends shall be avoided except where necessary to extend a cleanout so as to be accessible.

(e) Provision for future fixtures.-Drainage and vent piping provisions for future fixture installations shall consist of plugged fittings at the stack, or of piping installed without dead ends.

P108.9 Sanitary Drainage Fixture Units.-

(a) **Value for fixtures.**-Fixture unit values given in Table RS 16-12 shall be employed in computing the total load carried by a soil or waste pipe and shall be used with the tables for sizing soil, waste, drainage, and vent pipes.

(b) Values for continuous or semicontinuous flow.-Fixture unit values for continuous or semicontinuous flow into a drainage system, such as from a pump, ejector, air-conditioning equipment, or similar devices shall be computed on the basis of one fixture unit for each gpm of flow.

TABLE RS 16-12 SANITARY DRAINAGE FIXTURE UNIT VALUES ^a

| Fixture or Group | Fixture Unit Value |
|--|--------------------|
| Automatic clothes washer (2 in. standpipe) | 3 |
| Bathroom group consisting of a lavatory, bathtub or shower stall, and a water closet (direct flushometer valve)..... | 8 |
| Bathroom group consisting of a lavatory, bathtub or shower stall, and a water closet (flush tank) | 6 |
| Bathtub with or without overhead shower | 2 |
| Combination sink and wash tray | 3 |
| Dental unit or cuspidor | 1 |
| Dental lavatory | 1 |
| Drinking fountain | 1/2 |
| Dishwasher, domestic type | 2 |
| Floor drain | 2 ^{b*} |
| Kitchen sink, domestic type | 2 |
| Lavatory | 1 |
| Lavatory (barber shop, beauty parlor or surgeon's) | 2 |
| Lavatory, multiple type (wash fountain or wash sink), per each equivalent lavatory unit or set of faucets | 2 |
| Laboratory cup sink | 1 |
| Laboratory sink | 2 |
| Laundry tray (1 or 2 compartment) | 2 |
| Shower stall | 2 |
| Shower (group) per head | 2 |
| Sink (surgeon's) | 3 |
| Sink (flushing rim type, direct flush valve) | 6 |
| Sink (service type with trap standard) | 3 |
| Sink (service type with P trap) | 2 |
| Sink (pot, scullery, or similar type) | 4 |
| Urinal (1 in. flush valve) pedestal | 6 |
| Urinal (3/4 in. flush valve) stall or wall hung | 4 |
| Urinal (flush tank) | 4 |
| Water closet (direct flush valve) | 6 |
| Water closet (flush tank) | 4 |
| Unlisted fixture, 1 1/4 in. fixture drain and 1 1/2 in. trap size | 1 |
| Unlisted fixture, 1 1/2 in. fixture drain or trap size..... | 2 |
| Unlisted fixture, 2 in. fixture drain or trap size | 3 |
| Unlisted fixture, 2 1/2 in. fixture drain or trap size | 4 |
| Unlisted fixture, 3 in. fixture drain or trap size | 5 |
| Unlisted fixture, 4 in. fixture drain or trap size | 6 |

Note-

^a See section P108.9(b) for method of computing unit values for devices with continuous or semicontinuous flows.

^b Any floor drains provided in an elevator vestibule or in an elevator shaft shall be excluded from being counted as fixture units.

*Local Law 26-2004.

P108.10 Sizing the Sanitary Drainage Piping.-

(a) Drainage piping.-Sizes shall not be less than those permitted in Table RS 16-13, using the fixture unit values of Table RS 16-12.

(b) Sewer piping.-When more than one building house drain discharges into a private sewer within the property line, the sewer may be sized on a design basis and the slope of the sewer shall be predicated on the size selected, but in no case shall the slope be less than that required to produce a velocity in the sewer of less than 3 fps.

(c) Minimum size of soil and waste stacks.-No soil or waste stack shall be smaller than the largest horizontal branch connected thereto, except that a 4 in. x 3 in. water closet connection shall not be considered as a reduction in pipe size.

(d) Provision for future fixtures.-When provision is made for the future installation of fixtures, those provided for shall be considered in determining the required sizes of drain and vent pipes.

(e) Minimum size of underground drainage piping.-No portion of the drainage system installed underground or below a basement or cellar floor on ground shall be

less than 2 in. in diameter, except that drip pipes may be 1 in. if of copper or brass.

(f) Sizing of offsets in drainage piping.-

(1) OFFSETS OF 45 DEGREES OR LESS.-An offset in a vertical stack, with a change of direction of 45 degrees or less from the vertical, may be sized as a straight vertical stack.

(2) OFFSETS OF MORE THAN 45 DEGREES.-A stack with an offset of more than 45 degrees from the vertical shall be sized as follows:

a. The portion of the stack above the highest offset shall be sized as required for a regular stack based on the total number of fixture units above the offset.

b. The offset shall be sized as required for a building house drain (Table RS 16-13).

c. The portion of the stack below the offset shall be sized the same as the offset or based on the total number of fixture units on the entire stack, whichever is the larger.

d. A relief vent for the offset shall be installed as provided in section P109.12 and in no case shall a horizontal branch drain connect to the stack within 2 ft.

Reference Standard 16

above or below the offset.

(3) **OFFSETS ABOVE HIGHEST BRANCH.**-An offset in the stack vent above the highest horizontal branch shall be considered only as it affects the developed length of the vent. The horizontal offset and piping above the stack vent offset shall be of a non-scaling material.

(4) **OFFSETS BELOW LOWEST BRANCH.**-In the case of an offset in a soil or waste stack below the lowest horizontal branch, there shall be no change in diameter required if the offset is made at an angle of 45 degrees or less from the vertical. If such an offset is made at an angle greater than 45 degrees from the vertical, the required

diameter of the offset and the stack below it shall be determined as required for a building house drain.

(5) **OFFSETS PROHIBITED.**-No offset in a soil or waste line shall be made directly above any equipment used to prepare or store any food products, except where provided with protection from drips with a water tight copper pan extending 4 in. in each direction from the pipe wall and turned up at least 1/2 the diameter of the pipe but not less than 2 in. The pan shall extend at least 1 ft. beyond the fixtures or tables. Other methods may be used when permitted by the commissioner.

TABLE RS 16-13 MAXIMUM PERMISSIBLE LOADS FOR SANITARY DRAINAGE PIPING (IN TERMS OF FIXTURE UNITS)

| Pipe Diameter (in.) | Any horizontal branch or fixture at one story of stack | Total for Stack | House building Drain, and Building Branches from stacks | | | |
|-------------------------|--|-----------------|---|-----------------|-----------------|-----------------|
| | | | Slope (in. per ft.) | | | |
| | | | 1/16 | 1/8 | 1/4 | 1/2 |
| 1 1/2 ^a | 3 | 4 | np | np | np | np |
| 2 ^a | 6 | 8 | np | np | 21 | 26 |
| 2 1/2 ^a | 12 | 30 | np | np | 24 | 31 |
| 3..... | 20 ^b | 97 ^b | np | 20 ^b | 27 ^b | 36 ^b |
| 4..... | 160 | 507 | np | 180 | 216 | 250 |
| 5..... | 360 | 1445 | np | 390 | 480 | 575 |
| 6..... | ... | 2918 | np | 700 | 840 | 1000 |
| 8..... | ... | 6992 | 1440 | 1600 | 1920 | 2300 |
| 10..... | ... | | 2500 | 2900 | 3500 | 4200 |
| 12..... | ... | | 3900 | 4600 | 5600 | 6700 |

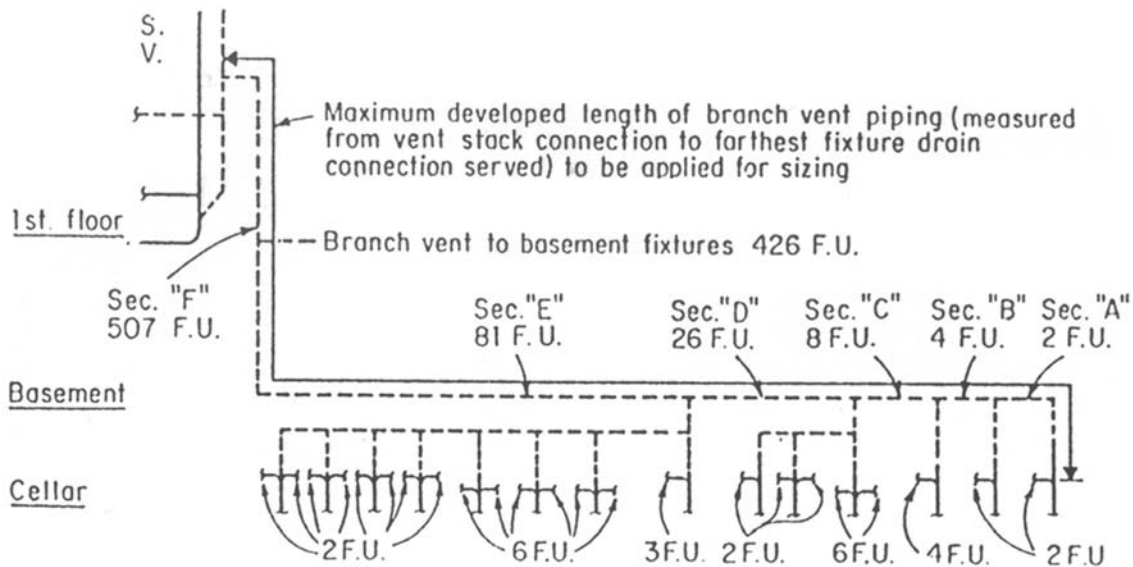

| SIZING SCHEDULE Max. developed length-70' | | |
|--|-------------|------------|
| BRANCH VENT SECTION | LOAD (F.U.) | SIZE (IN.) |
| A | 2 | 1 1/2 |
| B | 4 | 1 1/2 |
| C | 8 | 2 |
| D | 26 | 2 |
| E | 81 | 2 1/2 |
| F | 507 | 3 |

| SIZING SCHEDULE Max. developed length-200' | | |
|---|-------------|------------|
| BRANCH VENT SECTION | LOAD (F.U.) | SIZE (IN.) |
| A | 2 | 1 1/2 |
| B | 4 | 2 |
| C | 8 | 2 1/2 |
| D | 26 | 3 |
| E | 81 | 3 |
| F | 507 | 4 |

Figure RS 16-2. Sizing of Branch Vent Piping, Drop Vents to 1st Floor, Basement and Cellar Fixtures.

Reference Standard 16

Notes-

^a No water closets permitted.

^b Not over two water closets permitted.

np = not permitted.

P108.11 Drip Pipes.-Drips from pump bases, air conditioning drips, and similar clear water drips may be collected into a 1 in. pipe, and the pipe may be connected to the inlet side of a floor drain trap. Piping underground shall be of brass or copper.

Section P109.0 Vent Piping

P109.1 Size of Vents.-The nominal size of vent piping including vent headers shall be determined from its length and the total number of fixture units connected thereto, as provided in Table RS 16-14. In no case however, shall the nominal size be less than the following:

- (a) **Individual vent.**-1 1/2 in. or 1/2 the diameter of the drainage pipe to which it is connected, whichever is greater.
- (b) **Relief vent.**-1 1/2 in. or 1/2 the diameter of the soil or waste branch to which it is connected, whichever is greater.
- (c) **Branch vents.**-Branch vents connecting more than one individual vent to a stack or stack-vent shall be in

accordance with Table RS 16-14. The branch vent size shall be based upon the number of fixture units connected thereto, and the developed length of the branch vent measured from its vent stack (or stack-vent) connection to the farthest fixture drain connection served by the branch vent. See Figure RS 16-2.

(d) **Vent stacks.**-The developed length of a vent stack shall be measured from the base or point of connection with the attending soil or waste stack to the connection with a vent header or its termination above the roof. Stacks shall be sized in accordance with Table RS 16-14.

P109.2 Protection of Trap Seals.-The protection of trap seals from siphonage or back pressure shall be accomplished by the use of soil or waste stacks, vents, revents, back vents, continuous vents, or combinations thereof, installed in accordance with the requirements of this code, so that at no time shall the trap-seal be subjected to a pressure differential of more than 1 in. of water.

TABLE RS 16-14 SIZE OF VENT STACKS AND BRANCH VENTS

| Size of soil (in.) or waste stack | Fixture units Connected | Diameter of vent required (in.) | | | | | | | | |
|--|-------------------------------|---------------------------------|-----|-------|-----|-----|-----|-----|-----|----|
| | | 1 1/2 | 2 | 2 1/2 | 3 | 4 | 5 | 6 | 8 | 10 |
| Maximum developed length of vent (ft.)** | | | | | | | | | | |
| 1 1/2..... | 4 | 100 | † | .. | .. | .. | .. | .. | .. | .. |
| 2..... | 8 | 30 | 170 | † | .. | .. | .. | .. | .. | .. |
| 2 1/2..... | 30 | 15 | 70 | 175 | † | .. | .. | .. | .. | .. |
| 3..... | 97 | 6 | 24 | 89 | 250 | † | .. | .. | .. | .. |
| 4..... | 507 | * | * | 11 | 78 | 310 | † | .. | .. | .. |
| 5..... | 1445 | * | * | * | 16 | 110 | 380 | † | .. | .. |
| 6..... | 2918 | * | * | * | * | 34 | 143 | 380 | † | .. |
| 8..... | 6992 | * | * | * | * | * | 14 | 73 | 340 | † |
| 10..... | ... | * | * | * | * | * | * | * | * | † |

Notes-

*not permitted.

**A 1 1/2 in. vent may be used for 6 or less fixture units for a developed length of 15 ft. from the fixture to header regardless of developed length limiting the header size.

† unlimited

P109.3 Vent Stack and Stack Vents.-

(a) **Minimum size.**-Any building in which a building drain is installed shall have at least one 4 in. vent stack (or stack-vent) carried full size through the roof.

(b) **Vent stack required.**-Every building in which plumbing is installed shall have at least one 4 in. main stack or stack-vent, which shall run undiminished in size and as directly as possible, from the building drain through to the outdoor air above the roof. A vent stack shall be installed in conjunction with each soil or waste stack in a building containing three or more branch intervals; however, one vent stack may serve not more than two soil or waste stacks.

(c) **Connections at base and top.**-All main vents or vent stacks shall connect full size at their base to the building drain or to the soil or waste stack at or below the level of the lowest drainage connection to the soil or waste stack. All vent stacks shall extend undiminished

in size above the roof, or shall be reconnected to a vent header, or to the stack vent portion of the soil or waste stack, at least 6 in. above the flood level of the highest fixture connection discharging into the soil or waste stack.

(d) **Angle of offsets and connections.**-Offsets in the stack vent portion of soil and waste stacks (above the highest fixture drainage connection), offsets in vent stacks, and connections of vent stacks at the bottom to a soil or waste pipe or to the building house drain, shall be made at an angle of at least 45 degrees to the horizontal. However, where provision is made to wash out the scale above the offset or where the entire piping above such offsets is of nonscaling type, the offset angle may be reduced, provided there is sufficient slope for condensation to drain back to soil or waste pipe connections.

(e) **Vent headers.**-Where stack vents and vent stacks are connected into a vent header, such connections shall be made at the tops of the stacks. The vent header shall

Reference Standard 16

connect to a vent extension through the roof. The vent header material shall be of non-scaling type.

(f) **Sub-stack connections.**-Where it is desired to terminate stacks at a point below the roof terminus of the main vent stack, the sub-stack may connect to the main vent stack provided the portion of the main vent stack above the connection is sized for the total fixture unit load connected thereto, and for the maximum developed length of the stack or sub-stack.

P109.4 Vent Terminals.-

(a) **Extension above roofs.**-Extension of vent pipes through a roof shall be terminated at least 24 in. above the roof surface. Where a roof is to be used for any purpose other than weather protection, the vent extensions shall be run at least 7 ft. above the roof surface.

(b) **Size of vent extension.**-Each vent extension shall be at least as large as the soil stack, waste stack, vent stack, or vent header served thereby, but in no case less than 4 in. size. Where it is necessary to increase the size of a vent pipe at its vent extension, the change in size shall be made by use of a long increaser immediately below the roof.

(c) **Waterproof flashings.**-Each vent terminal shall be made watertight by proper flashing.

(d) **Attachments prohibited.**-Vent terminals shall not be used for the purpose of attaching flag poles, television aerials, or for similar purposes.

(e) Location of vent terminal.-

(1) No vent terminal shall be located directly beneath any door, operable window, or other ventilating opening of the building or of an adjacent building, nor shall any such vent terminal be within 10 ft. horizontally of such an opening unless it is at least 3 ft. above the top of such opening.

(2) Vent extensions shall not be run through an exterior wall.

(f) **Extensions outside building.**-No soil, waste, or vent pipe extension shall be run or placed on the outside of a wall of any building, unless such exterior installation on penthouses is permitted by the commissioner.

P109.5 Vent Grading and Connections.-

(a) **Vent grading.**-All vent and branch vent pipes shall be so graded and connected as to drain back to the soil or waste pipe by gravity.

(b) Height above fixtures.-

(1) A connection between a vent pipe and a vent stack or stack vent shall be made at least 6 in. above the flood-level rim of the highest fixture served by the vent. Horizontal vent pipes forming branch vents or relief vents shall be at least 6 in. above the floor-level rim of the highest fixture served.

(2) See Figure RS 16-4 for typical methods of compliance.

P109.6 Stack Venting.-

(a) **Highest fixture connection to soil or waste stack.**-Where a fixture discharges directly into a soil or waste stack at a level above all other drain connections thereto, the stack vent may serve as the vent for the fixture trap provided that:

(1) Such vent connection is above the level of the dip of the trap (except for fixture drains of floor-outlet type water closets and urinals, and of floor-outlet type trap standards for service sink):

(2) Such vent connection is within the distance permitted in this standard.

P109.7 Common Vents.-

A common vent may serve as an individual vent for not more than two fixture traps. Such common vent shall connect at the junction of the two fixture drains and shall rise vertically from the connection before offsetting horizontally.

P109.8 Fixture Vents.-

(a) **Distance of trap from vent.**-Each fixture trap shall have a protecting vent so located that the developed length of the fixture drain from the trap weir to the vent fitting is not more than 2 ft. 0 in.

(b) **Vent location.**-The vent pipe opening from a soil

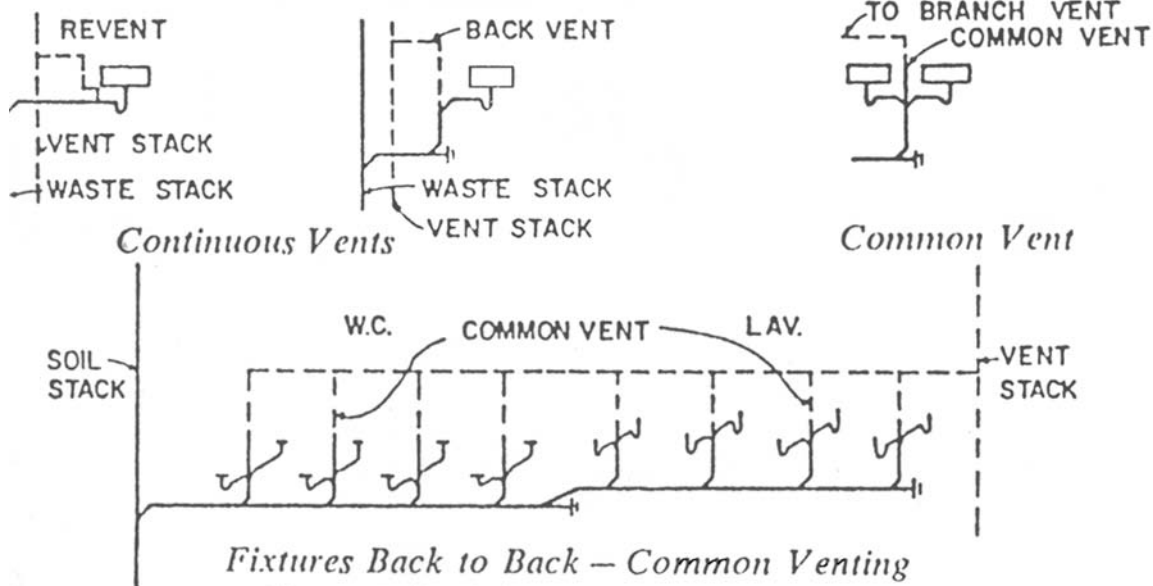

Figure RS 16-4. Vent Arrangements.

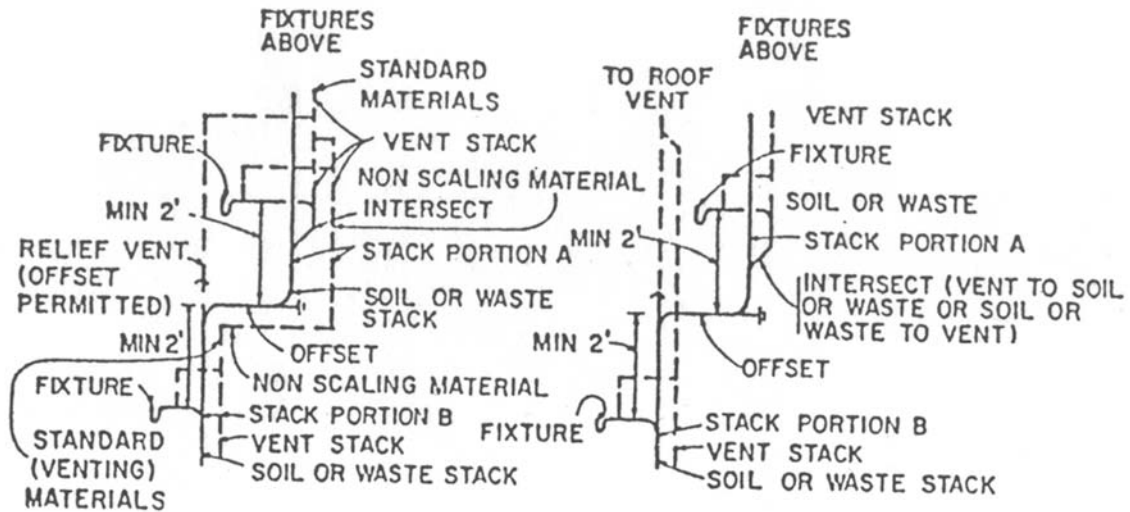

Figure RS 16-6. Offsets in Buildings Five Stories or More.

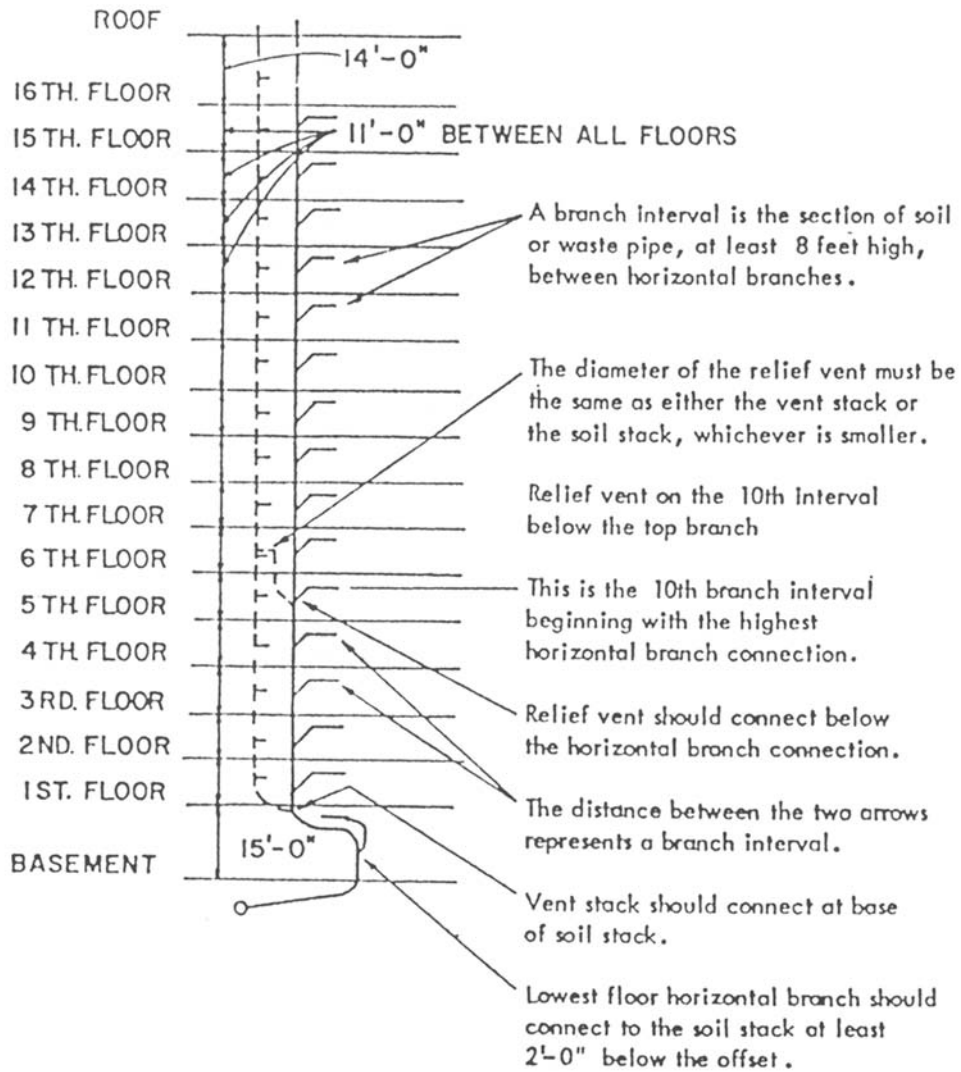

Figure RS 16-7. Relief Vents for Stack of More Than Ten Branch Intervals.

Reference Standard 16

or waste pipe, except for water closets and similar fixtures, shall not be below the weir of the trap.

(c) **Crown venting prohibited.**-No vent shall be installed within two pipe diameters of the trap weir.

(d) **Floor drain vents.**-No vents will be required for piping serving floor drains when the floor drain is located not more than 15 ft. 0 in. from a vented line.

P109.9 Relief Vents.-

(a) **Vertical offsets in building drains.**-Where an offset between horizontal portions of the building house drain rises vertically more than 10 ft. a relief vent shall be provided at the top of the vertical offset. The size of such relief vent shall be at least 1/2 the diameter of the building house drain at the offset and at a sufficient height so that the relief vents cannot serve as soil or waste pipes in the event of a stoppage in the vertical offset. See Figure RS 16-6 for typical installation.

(b) **Soil and waste stacks more than ten stories high.**-Soil and waste stacks more than ten stories high shall be provided with a yoke relief vent at each tenth story, counting from the top story. The lower end of the yoke vent shall connect to the soil or waste stack through a wye located below the horizontal branch drain serving fixtures in that story, and the upper end shall connect to the vent stack through a tee or inverted wye at least 3 ft. above the floor level. See Figure RS 16-7 for typical installation.

P109.10 Suds Pressure Zones Vents.-

(a) Where sinks, laundry trays, laundry washing machines, bathtubs, and similar fixtures in which sudsy detergents are normally used and discharged at an upper floor level into a soil or waste stack that also serves fixtures in other occupancy units at a lower floor

level, the drainage and vent piping for such lower fixtures shall be arranged so as to avoid connection to suds pressure zones in the sanitary drainage and vent systems. If connected to the sanitary system, a suds relief vent relieving to a nonpressure zone shall be provided at each suds pressure zone where such connections are installed. The size of such relief vent shall be at least 3/4 the diameter of the piping in which the pressure zone occurs, but not less than 2 in.

(b) Suds pressure zones shall be considered to exist at the following locations in sanitary drainage and vent systems when the piping serves fixtures on two or more

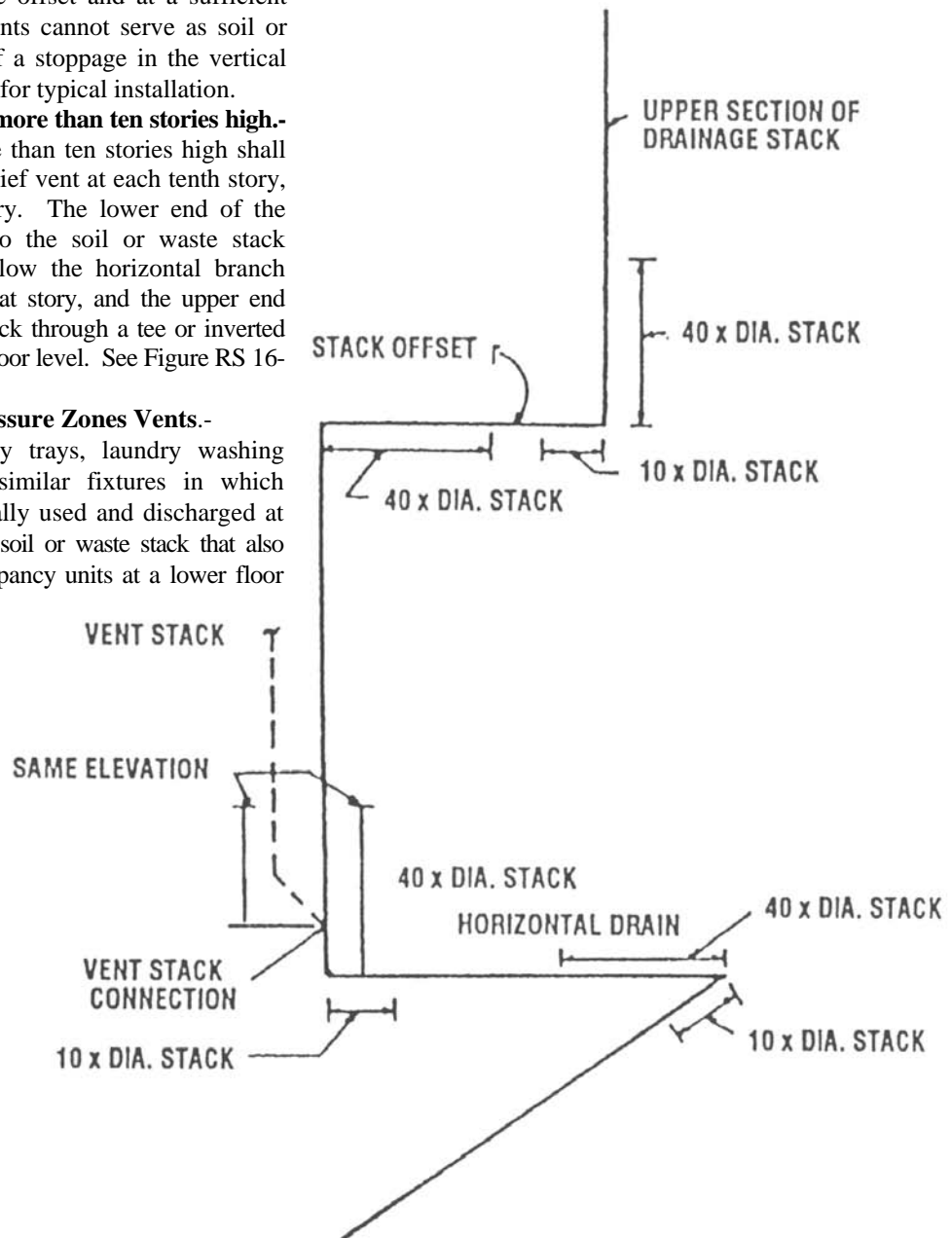

Figure RS 16-8. Suds Pressure Zones.

Reference Standard 16

floors that receive wastes that contain sudsy detergents. See Figure RS 16-8 for location of suds pressure zones.

(1) In a soil or waste stack a zone shall be considered to exist in the vertical portion within 40 stack diameters of the base fitting.(2) In the horizontal drain at the base of a soil or waste stack a zone shall be considered to exist in the horizontal portion within ten stack diameters of the base fitting. Where a 60 degree or 90 degree fitting is installed in the horizontal drain, a zone shall be considered to exist in the horizontal portion within 40 drain diameters upstream of and 10 drain diameters downstream of the fitting.

(3) In a soil or waste stack offset of 60 degrees or 90 degrees, a zone shall be considered to exist in the vertical portion of the stack within 40 stack diameters of the base fitting for the upper section of the stack. The zone shall be considered to exist in the horizontal offset within 10 stack diameters of such base fitting and within 40 stack diameters of the top fitting for the lower section of the stack.

(4) In a vent stack that has its base connected to a suds pressure zone in the sanitary drainage system, a zone shall be considered to exist in the portion of the vent stack extending from its base connection up to the lowest branch vent fitting located above the level of the suds pressure zone in the sanitary drainage system.

P109.11 Permitted Combination Waste and Vent Systems.-A combination waste and vent piping system, limited for use as a means of venting the traps of floor drains and laboratory sinks, shall be permitted in conjunction with horizontal branch waste piping of an independent flammable oil waste system or acid waste systems, and as described under indirect wastes and special wastes. See Figure RS 16-9 for typical installation.

Section P110.0 Storm Drainage Piping

P110.1 Permits.-

(a) Permits for the installation of a building house storm sewer from the street line to, and including the spur connection at the street sewer shall be obtained in accordance with the requirements of the building code. Street sewer connections shall be made as provided in Section P108.2(a), (b), (c) and (d).

***P110.2 Disposal of Storm Water.-**

(a) Definitions.-As used in this section:

(1) "Block" means a tract of land bounded by streets, public parks, railroad rights-of-way when located at or above ground level but not including sidings or spurs within a lot in the same ownership as the lot, airport boundaries, pierhead lines or shore lines, where no pierced lines have been established, or corporate boundary lines of New York city;

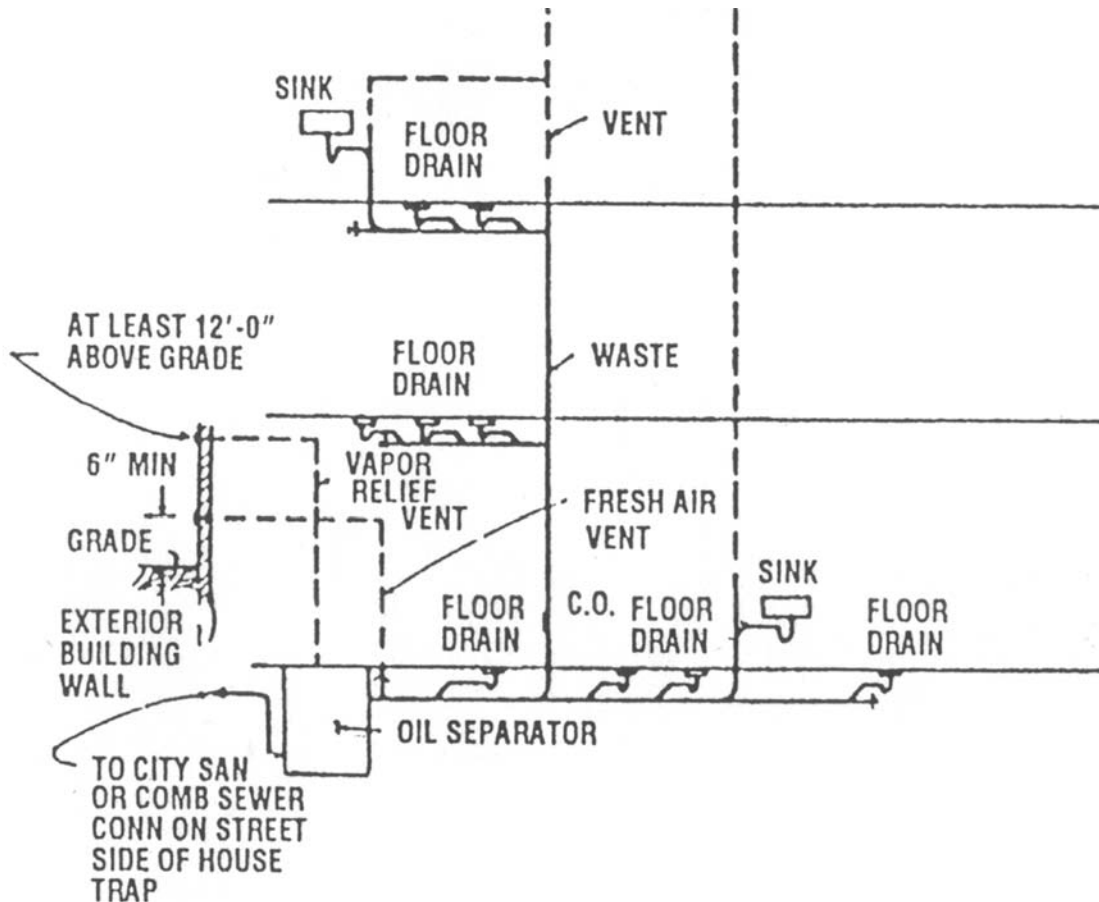

Figure RS 16-9. Combination Waste and Vent Oil Waste Drainage.

Reference Standard 16

- (2) "Building combined sewer" means a building sewer intended to convey all types of wastewater, subject to certain restrictions;
- (3) "Building sewer" means a sewer consisting of the part of the horizontal piping of a drainage system that extends from the end of a building house drain, as defined in section P100.00 of reference standard RS-16 of this code, to a street sewer or to another point of disposal. Building combined sewers and building storm sewers are types of building sewers;
- (4) "Building storm sewer" means that part of the horizontal piping of a storm water drainage system that extends from a building house storm drain, as defined in section P100.00 of reference standard RS-16 of this code, to a street storm sewer, a street combined sewer or another point of disposal;
- (5) "Catch basin" means a storm water inlet connected to a storm sewer or a combined sewer;
- (6) "Commissioner" means the commissioner of the department of buildings or his or her designee;
- (7) "Development" means a tract of land which has been subdivided into two or more lots, whether or not such tract has been developed as by the installation of any utilities or the construction of any streets or buildings or other structures;
- (8) "Impermeable soil" means soil of classes 1-65, 2-65, 3-65, 4-65, 5-65, 9-65, 10-65 or 11-65, as set forth in section 27-675 and table 11-2 of this code. Uncontrolled fill, as described in section 27-679 of this code, shall be considered impermeable soil;
- (9) "Impervious surfaces" means those areas of a lot or development covered by roofs, terraces, outside balconies, canopies, or paved surfaces such as driveways, sidewalks, courts, streets, or parking areas. A surface paved with an accepted asphalt or other acceptable material which, after compaction, is not thicker than one and one-half inches shall not be considered impervious, provided such surface will pass an amount of water equivalent to one-half inch of rainfall per hour and is underlaid by permeable soil;
- (10) "Lot" means a portion or parcel of land considered as a unit; a zoning lot;
- (11) "Owner" means a person in whom legal or equitable title to property or premises is vested, a mortgagee or vendee in possession of premises, an assignee of rents, a receiver of premises or a person listed as owner or agent for an owner on the records as to real property ownership maintained by the bureau of city collections of the department of finance unless such person establishes that such records are erroneous or, if claiming that he is an agent of the owner, furnishes the identity of the owner;
- (12) "Permeable soil" means soil at least five feet in depth of classes 6-65, 7-65, or 8-65, as set forth in section 27-675 and table 11-2 of this code, or porous material as determined by percolation tests. Controlled fill, as described in section 27-679 of this code, shall be considered permeable soil;
- (13) "Person" means a natural person, company, partnership, corporation, association, governmental body or other legal entity, including any individual or entity acting in a representative capacity;
- (14) "Private" means not public;
- (15) "Public" means owned by the city and intended for use by the public, subject to restrictions which the city or agencies thereof may impose;
- (16) "Storm water" means rain water or surface water;
- (17) "Street combined sewer" means a street sewer which is intended to receive the discharge of all types of wastewater, subject to certain restrictions, from one or more building sewers and catch basins and to convey such wastewater to an intercepting sewer, a private sewage disposal system or some other point of disposal;
- (18) "Street sewer" means a sewer located in the bed of a street or elsewhere which is intended to receive the discharge of all or certain types of wastewater from one or more building sewers and, in some cases, from catch basins, and to convey such wastewater to points of disposal. Street combined sewers and street storm sewers are types of street sewers;
- (19) "Street storm sewer" means a street sewer which is intended to receive the discharge of storm water from one or more building storm sewers and catch basins and to convey such storm water to a point of disposal;
- (20) "Substantial horizontal enlargement" means (a) an increase in the area of a lot covered by impervious surfaces which exceeds twenty percent of the existing area so covered, provided that the existing and enlarged areas so covered exceed one thousand square feet in total, or (b) an increase in the area of a lot covered by impervious surfaces which exceeds two hundred square feet, provided that the commissioner has previously approved the discharge of storm water from a building located on such lot by means of splash blocks; and
- (21) "Tidal creek" means any creek where the level of water rises and falls with tidal action, or would do so if not impeded by artificial structures including but not limited to tide gates.
- ** (b) Disposal of storm water when public sewers are located in front of the property.**-Where any new building or other substantial horizontal enlargement is to be constructed on a lot and the department determines that a public street storm sewer or public street combined sewer is located directly in front of any point of any boundary of such lot and that it would be feasible, pursuant to subdivision (j) of this section, to discharge storm water from such lot into such street storm sewer or street combined sewer, the owner of such lot shall ensure that all storm water falling or coming to rest on all impervious surfaces within such lot will be discharged to such street storm sewer or street combined sewer. Such discharge shall be by means of building storm sewers or building combined sewers, provided that no sewage shall be discharged into a public street storm sewer. If the department determines that such street storm sewer or street combined sewer has partial capacity to receive the storm water discharged from such lot, the remainder of such storm water shall be discharged pursuant to subdivision (c) of this section.
- ** (c) Disposal of storm water when public sewers are not located in front of the property.**-Where any new building or other substantial horizontal enlargement is to be constructed on a property and the department

Reference Standard 16

determines that no public street storm sewer or public street combined sewer is located directly in front of any point of any boundary of such property, the owner of such property shall ensure that all water falling or coming to rest on all impervious surfaces within such property will be discharged as follows:

(1) Where one or more buildings is to be constructed on the subject property in any occupancy group other than occupancy group J, drainage of storm water shall be by means of one building storm sewer or building combined sewer for each such building, which sewer shall be connected to a public street storm sewer or public street combined sewer. Such connection shall be by means of a house connection constructed in accordance with section P108.2 of this reference standard, the rules and regulations of the department and the applicable rules and regulations of the department of environmental protection, department of transportation and bureau of franchises. Provided, however, that no sewage shall be discharged into a public street storm sewer. Provided further, that the provisions of this paragraph shall apply only when

(A) the total area of impervious surfaces to be constructed on the subject property equals or exceeds twenty thousand square feet; and

(B) the commissioner of environmental protection has determined that a public street storm sewer or public street combined sewer is located within two hundred feet of any point of any boundary of such property, measured along a street, alley, right-of-way or easement; and

(C) the commissioner of environmental protection determines that it would be feasible, pursuant to subdivision (j) of this section, to discharge storm water in accordance with the provisions of this paragraph.

(2) Where paragraph one of this subdivision does not apply, drainage of storm water shall be by means of:

(A) On-site disposal of storm water in accordance with the provisions of section P110.13 of this reference standard; or

(B) Where a lot abuts a paved street which contains curbs and has been improved in accordance with the requirements of the department of transportation, drainage of storm water to the boundary of such lot abutting such street. From such boundary, such storm water may be discharged through an under-sidewalk drain or drains onto such street, provided that catch basins adequate to receive such storm water are located or installed in accordance with the requirements of this code and of the department of environmental protection. The means of drainage set forth in this subparagraph shall be used to discharge storm water from a lot only when the commissioner, with the concurrence of the commissioners of transportation and environmental protection, determines that such use is feasible; or

(C) Where a lot abuts any street, drainage of storm water by means of enclosed drainage pipes and building storm sewers or building combined sewers to the boundary of such lot abutting such street. From such boundary, all such storm water, together with all storm water falling or coming to rest on all streets and other

paved areas outside of such lot which are constructed or altered for the primary purpose of improving vehicular or pedestrian access thereto, shall be conveyed by sewers, constructed in accordance with the requirements of subdivision (h) of this section and other requirements of the department and the department of environmental protection, to a public street sewer. In no event shall sewage be discharged into a public street storm sewer. When necessary to comply with the requirements of this subparagraph, the owner of such lot shall be responsible for installation of a controlled flow storm water system in accordance with the requirements of section P110.6 of this reference standard; or

(D) In the case of any lot or development, drainage of storm water from the impervious surfaces of such lot or development by means of drainage pipes, culverts, paved swales, ditches or watercourses. Such storm water may be conveyed by such means across lot lines within a development and through under-sidewalk drains within a lot or development to a boundary of such lot or development. From such boundary, such storm water, together with all storm water falling or coming to rest on all streets and other paved areas outside of such lot or development constructed or altered in connection with the construction of one or more buildings on such lot or in such development for the primary purpose of improving vehicular or pedestrian access thereto, shall be conveyed to one of the points of disposal set forth in subdivision (d) of this section. The means of storm water disposal described in this subparagraph may be utilized only if:

(i) The owner or owners of the lot or development shall submit to the commissioner a comprehensive grading and drainage plan for such development which, in the commissioner's judgment, will satisfy the drainage requirements set forth in this section. The commissioner of environmental protection and, if such plan provides for drainage of storm water into a catch basin located in a public or private street, the commissioner of transportation shall concur in such judgment; and

(ii) When the plan described in clause (i) of this subparagraph provides for the drainage of storm water from one lot in a development across other property in such development, the owner or owners of such development shall obtain an agreement between each owner of property within such development from which or across which such storm water will be drained and the commissioner.* Such agreement shall bind each such owner and his or her heirs, successors and assigns to properly maintain the storm water drainage system. Such agreement shall be filed in the office of the county clerk in the county in which the development is located; or

(E) Any means of drainage acceptable to the commissioner, including any combination of the means specified in subparagraphs (A), (B), (C), and (D) above. Provided, however, that over-sidewalk drains shall not be permitted. Provided, further, that the commissioner shall consult with the commissioner of environmental protection or the commissioner of transportation, as appropriate, prior to approving any such combination of means or any means of drainage not specified in this paragraph.

*Language missing. So in original.

Reference Standard 16

(d) Points of discharge for storm water from a lot or development.-Storm water drained from a lot or development pursuant to subparagraph (D) of paragraph two of subdivision (c) of this section may be discharged into:

(1) the New York harbor, or a point on a tidal creek acceptable to the commissioner of environmental protection as an adequate storm water outlet; provided that only building storm sewers and, if necessary, street storm sewers are constructed and that no sewage is discharged at such a point of disposal, and provided further that such outlets shall only be used in compliance with applicable provisions of law; or

(2) a public street storm sewer or public street combined sewer, regardless of its distance from the property, to which the commissioner of environmental protection determines that discharge of storm water is feasible, pursuant to subdivision (j) of this section, provided that no sewage shall be discharged into a street storm sewer; or

(3) an existing private street storm sewer or private street combined sewer to which the commissioner of environmental protection determines that discharge of storm water is feasible, pursuant to subdivision (j) of this section, provided that such street sewer connects with a public street sewer or, if it is a private storm sewer, discharges directly into the New York harbor, or into a point on a tidal creek acceptable to the commissioner of environmental protection as an adequate storm water outlet, in accordance with applicable provisions of law, and provided further that no sewage shall be discharged into a street storm sewer.

(e) Areaway drains.-Areaway drains may be connected to the footing or subsoil drainage system when permitted by the commissioner. Garages installed in a manner that would permit the flow of storm water from surrounding surfaces to enter the garages shall be provided with a gravity drain, or a sump and pump connected to a storm sewer, or other means of disposal as provided in this reference standard.

(f) Drains carrying clear water.-All drains carrying clear water, i.e., air conditioning drips, pump drips, cooling water, etc., may discharge into the storm water drainage system through an indirect waste connection discharging into a trapped funnel or drain.

(g) Drainage system design.-The storm water drainage system shall be designed, constructed and maintained to guard against fouling, deposit of solids and clogging and shall be provided with adequate cleanouts so arranged that the pipes may be readily cleaned.

(h) Maximum required capacity for street storm sewers or street combined sewers required by this section.-The commissioner of environmental protection may require an owner of a lot or a development who is required by this section to construct street storm sewers or street combined sewers to construct such sewers with a capacity not to exceed twenty-five percent above and beyond the capacity which the commissioner of environmental protection determines is needed for the disposal of storm water falling or coming to rest on such property together with storm water falling or coming to rest on all streets and other paved areas outside of such property which are constructed or altered in connection with the construction of a building or other substantial horizontal enlargement

on such property for the primary purpose of improving vehicular or pedestrian access thereto. The department of environmental protection reserves the right to construct catch basins connected to such sewers at the cost and expense of the city, to alleviate flooding or ponding conditions, provided that the commissioner of environmental protection determines that the capacity of such sewers shall not be exceeded.

(i) Repair of defects in catch basins and sewers required.-Any owner of property who causes any catch basin or any sewer which shall lie outside of such property to be constructed pursuant to subdivision (c) of this section shall cause all defects in such catch basin or sewer and all faults in its installation to be repaired for a period of two years after it has been installed, immediately after the commissioner of environmental protection orders such person to do so.

(j) Feasibility of discharging storm water into a street storm sewer or a street combined sewer.-The commissioner of environmental protection shall determine that the discharge of storm water into a street storm sewer or a street combined sewer pursuant to this section is feasible if he finds that:

(1) the sewer is of adequate capacity to receive all such storm water or would be adequate to receive it if the owner of property installed controlled flow storm water systems, in accordance with the requirements of section P110.6 of reference standard RS-16 of this code, to restrict the maximum anticipated storm water flow to a level set by the commissioner of environmental protection;

(2) the sewer is in adequate physical condition to receive such storm water;

(3) no physical obstacle which would make conveyance of storm water to the sewer impracticable exists between the sewer and the boundaries of the development or lot from which such storm water shall be discharged;

(4) conveyance of such storm water to the sewer is not impracticable because of the elevation of the sewer in relation to the development or lot from which such storm water shall be discharged;

(5) the sewer is located in the same drainage area as all or most of the development or lot from which such storm water shall be discharged; and

(6) no other factor reasonably related to the conveyance of such storm water from such development or lot to the sewer would make the discharge of such storm water into the sewer impracticable or undesirable as a proper means of storm water disposal.

(k) Time by which construction of the storm water drainage system required by this section shall be completed.-

The storm water drainage system for property required by this section shall be completed prior to the issuance of a certificate of occupancy by the department of buildings for, and actual occupancy of, the building or other substantial horizontal enlargement in connection with which such storm water drainage system is being constructed.

(l) Contractual obligations of the city not abrogated.-The provisions of this section shall not be construed to abrogate or contravene any contractual obligation of the city to construct storm water drainage systems or parts thereof. The requirements of subdivisions (b), (c), (d)

Reference Standard 16

and (i) of this section shall be inapplicable to an owner of property insofar as they relate to any construction work required to be performed by the city pursuant to such a contractual obligation.

(m) Remedies for non-functioning systems.-If the commissioner determines that a system of storm water disposal which has been previously approved under the provisions of this code or of previous codes is no longer providing adequate drainage of storm water from a lot or development, he or she shall order repair of such system as required by section 27-127 of this code; or if, in the judgment of the commissioner, repair of such system is not sufficient to ensure adequate drainage of storm water from such lot or development, he or she shall order that one of the methods of storm water disposal set forth in subdivisions (b) and (c) of this section shall be used to provide such drainage. The commissioner may apply to the board of standards and appeals for modification of the certificate of occupancy of any building constructed on such lot or development to require the use of such method.

**Local Law 103-1989; Local Law 7-1974*

*** Local Law 65-1996*

P110.3 Storm Water Drainage to Sanitary Sewer Prohibited.-Storm water shall not be drained into sanitary sewers intended for sewage only.

P110.4 Size of Storm Drains and Leaders.-

(a) Building storm drain.-The size of the building storm drain or any of its horizontal branches, except the branch serving a single roof drain, having a slope of 1/2 in. per ft. or less shall be based upon the maximum

projected roof or paved area to be handled according to Table RS 16-17.

(b) Storm sewers.-Where more than one building storm drain discharges into a private sewer within the property line, the sewer may be sized on a rational sewer design basis and the slope of the sewer shall be predicated on the size selected; but in no case shall the slope be less than that required to produce a velocity in the sewer of at least 3 fps.

(c) Vertical leaders.-Vertical leaders, including the branch to a single roof drain, shall be sized on the maximum projected roof area in accordance with Table RS 16-18. The equivalent diameter of square leader may be taken as the diameter of that circle which may be inscribed within the cross-sectional area of the leader. The equivalent diameter of a rectangular leader shall be taken as the number of standard size circular leaders, having a diameter equal to the short dimension of the rectangular leader that can be fitted within the rectangular leader. For example, the equivalent diameter of a 4 in. by 3 in. rectangular leader is 1-1/3 3 in. circular leaders.

(d) Roof gutters.-The size of a semicircular gutter shall be based on the maximum projected roof area according to Table RS 16-19.

(e) Combined drains and sewers.-To compute the size of a combined drain or sewer, the fixture units and the square feet of drained area shall be converted to their equivalent square footage or drainage area from Table RS 16-20 and either Table RS 16-13 or RS 16-17 shall be used to determine the pipe size required. For intermediate values, interpolation shall be used.

TABLE RS 16-17 SIZE OF HORIZONTAL STORM DRAINS

| Diameter of Drain (in.) | Maximum Projected Roof Area for Various Slopes of Drains | | |
|-------------------------|--|---------------------------|---------------------------|
| | 1/8 in. Slope Square Feet | 1/4 in. Slope Square Feet | 1/2 in. Slope Square Feet |
| 2 | 250 | 350 | 500 |
| 2 1/2 | 357 | 505 | 714 |
| 3 | 690 | 930 | 1,320 |
| 4 | 1,500 | 2,120 | 3,000 |
| 5 | 2,700 | 3,800 | 5,320 |
| 6 | 4,300 | 6,100 | 8,700 |
| 8 | 9,300 | 13,000 | 18,400 |
| 10 | 16,600 | 23,500 | 33,000 |
| 12 | 26,700 | 37,500 | 53,000 |
| 15 | 47,600 | 67,000 | 95,000 |

TABLE RS 16-18 SIZE OF VERTICAL LEADERS

| Diameter of Leader or Conductor (in.) | gpm. | Maximum Projected Roof Area (sq. ft.) |
|---------------------------------------|-------|---------------------------------------|
| 2 | 22.6 | 433 |
| 2 1/2 | 39.6 | 779 |
| 3 | 66.6 | 1,278 |
| 4 | 143 | 2,745 |
| 5 | 261 | 4,992 |
| 6 | 423 | 8,121 |
| 8 | 911 | 17,491 |
| 10 | 1,652 | 31,718 |

Reference Standard 16

TABLE RS 16-19 SIZE OF ROOF GUTTERS ^a

| Diameter of Gutter ^a (in.) | Maximum Projected Roof Area for Gutters of Various Slopes | | | |
|---------------------------------------|---|-------------------------|-------------------------|-------------------------|
| | 1/16 in. Slope (sq. ft.) | 1/8 in. Slope (sq. ft.) | 1/4 in. Slope (sq. ft.) | 1/2 in. Slope (sq. ft.) |
| 3 | 144 | 192 | 272 | 385 |
| 4 | 288 | 409 | 575 | 815 |
| 5 | 500 | 705 | 1,000 | 1,420 |
| 6 | 770 | 1,090 | 1,540 | 2,220 |
| 7 | 1,150 | 1,560 | 2,220 | 3,120 |
| 8 | 1,590 | 2,250 | 3,180 | 4,490 |
| 10 | 3,600 | 4,080 | 5,780 | 8,000 |

Note-

^a Gutters other than semicircular may be used provided they have the same cross-sectional area.

P110.5 Values for Continuous Flow.-Where there is a continuous or semi-continuous discharge into the building storm drain or building storm sewer, as from a pump, ejector, air conditioning unit, or similar device, each gallon per minute of such discharge shall be computed as being equivalent to 19 sq. ft. of roof area.

P110.6 Controlled Flow Storm Water System.-In lieu of sizing the storm drainage system in accordance with section P110.4, the roof drainage may be sized on controlled flow and the storage of the storm water on the roof, provided the following conditions are met:

- (a) The water of a 10-year frequency storm is not stored on the roof for more than 24 hr.
- (b) The water depth on the roof does not exceed 3 in. during the above storm.
- (c) The roof is level and 45 degree cants are installed at all walls or parapets.
- (d) Flashing extends at least 6 in. above the roof level and scuppers are placed in the parapet wall 4 in. above the roof level.

(e) No less than two drains are installed in roof areas 10,000 sq. ft. or less; and at least four drains in roof areas over 10,000 sq. ft.

(f) Separate storm and sanitary drainage systems are installed within the building.

(g) Control is by proportional weirs and not by mechanical devices or valves.

(h) Calculations for this type of system are submitted with the required plans and piping is sized in accordance with gallon per minute ratings in Table RS 16-18.

(i) Drains on set backs may be connected to the controlled storm drainage if:

- (1) The set back is designed for storing the water, or
- (2) The square footage of drainage area of the set back is converted to gallons per minute flow on the basis of 1 gpm for each 19 sq. ft. of roof area, and the storm water pipe sizes in the controlled system are predicated on carrying the sum of the loads.
- (3) The branch from each of the roof drains that are not arranged and equipped for controlled flow conform to tables RS 16-17 and RS 16-18.

TABLE RS 16-20 "FIXTURE UNIT-DRAINAGE SQUARE FOOTAGE" EQUIVALENT

| Drainage Area (sq. ft.) | Fixture Unit Equivalent |
|---------------------------|-------------------------|
| 180 | 6 |
| 260 | 10 |
| 400 | 20 |
| 490 | 30 |
| 1,000 | 105 |
| 2,000 | 271 |
| 3,000 | 437 |
| 4,000 | 604 |
| 5,000 | 771 |
| 7,500 | 1,188 |
| 10,000 | 1,500 |
| 15,000 | 2,500 |
| 20,000 | 3,500 |
| 28,000 | 5,500 |
| each additional 3 sq. ft. | 1 fixture unit |

Reference Standard 16

P110.7 Traps on Storm Drains and Leaders.-

(a) **Where required.**-Leaders and storm drains when connected to a combined sewer shall be trapped. No fresh air inlet will be required for building storm drains. Intake and exhaust plenum drains connected to a storm drain shall be trapped. One trap may serve more than one drain if any drain served by the trap is not more than 15 ft. from the trap.

(b) **Where not required.**-No traps shall be required for storm water drains that are connected to a building house drain or building house sewer carrying storm water exclusively.

(c) **Trap equivalent.**-A hooded catch basin located within the street line shall be the equivalent of a building or house trap for the connection to a street combined sewer.

(d) **Method of installation.**-Individual storm water traps shall be installed on the storm water drain branch serving each conductor, or a single trap shall be installed in the main storm drain just before its connection with the combined building sewer, main drain, or public sewer.

P110.8 Leaders or Storm Water Piping.-

(a) **Improper use of storm water piping.**-Leader or storm water pipes shall not be used as soil, waste, or vent pipes.

(b) **Protection of rain water conductors.**-Rain water conductors installed along alleyways, driveways, or other locations where they may be exposed to damage shall be protected by metal guards, be recessed into the wall, or be constructed of pipe.

(c) **Method of combining storm with sanitary drainage.**-The sanitary and storm-drainage system of a building shall be entirely separate except that where a combined street sewer is deemed available, the building storm drain may be connected, in the same horizontal plane through a trap and a single fitting to the combined drain or sewer at least 40 pipe diameters downstream from any soil stack.

P110.9 Roof Drain Strainers.-

(a) **General use.**-All roof areas, except those draining to hanging gutters, shall be equipped with roof drains having strainers extending at least 4 in. above the surface of the roof immediately adjacent to the roof drain. Strainers shall have an available inlet area above roof level at least 1 1/2 times the area of the conductor or leader to which the drain is connected.

(b) **Flat decks.**-Roof drain strainers for use on such decks, parking decks, and similar areas, normally serviced and maintained, may be of the flat surface type and set flush with the deck, and shall have an available inlet area at least twice the area of the conductor or

leader to which the drain is connected.

P110.10 Roof Drain Flashings Required.-

The connection between roofs and roof drains that pass through the roof and into the interior of the building shall be made watertight by the use of proper flashing material.

P110.11 Expansion Joints Required.-

Expansion joints or sleeves shall be provided where temperature variation or physical conditions may cause excessive stress or movement in the drain or piping.

P110.12 Sanitary and Storm Sewers.-

Where separate systems of sanitary drainage and storm water drainage are installed in the same property, the storm and sanitary building sewers and drains may be laid side by side in the same trench.

*** P110.13 On-Site Disposal.-**

(a) Storm water, as defined in subdivision (a) of section P110.2 of this reference standard, falling on areaways 25 sq. ft. or less in area may be leached into the ground within the areaway if the ground water is at least 2 ft. below the elevation of the areaway.

(b) An owner of a lot, as defined in subdivision (a) of section P110.2 of this reference standard, may dispose of all storm water falling or coming to rest within such lot on-sight only as permitted by the provisions of subdivision (c) of section P110.2 of this reference standard.

(c) Drywells shall be the only method of on-site disposal of storm water permitted, except as provided in subdivision (a) of this section or unless an alternate method of on-site disposal is approved by the commissioner with the concurrence of the commissioner of environmental protection or the commissioner of transportation, as appropriate, pursuant to subparagraph (E) of paragraph two of subdivision (c) of section P110.2 of this reference standard. Drywells shall be constructed in accordance with the following provisions:

(1) Except as provided in paragraph two of this subdivision, the size of a drywell shall be predicated on a soil percolation test performed in accordance with the provisions of section P113.9 of this reference standard, and shall be based upon rainfall of two inches in a twenty-four-hour period on all impervious surfaces where a site is underlaid by permeable soil. Where a site is underlaid by impermeable soil, the size of a drywell shall be based upon rainfall of two inches in a twenty-four hour period over the entire site.

Reference Standard 16

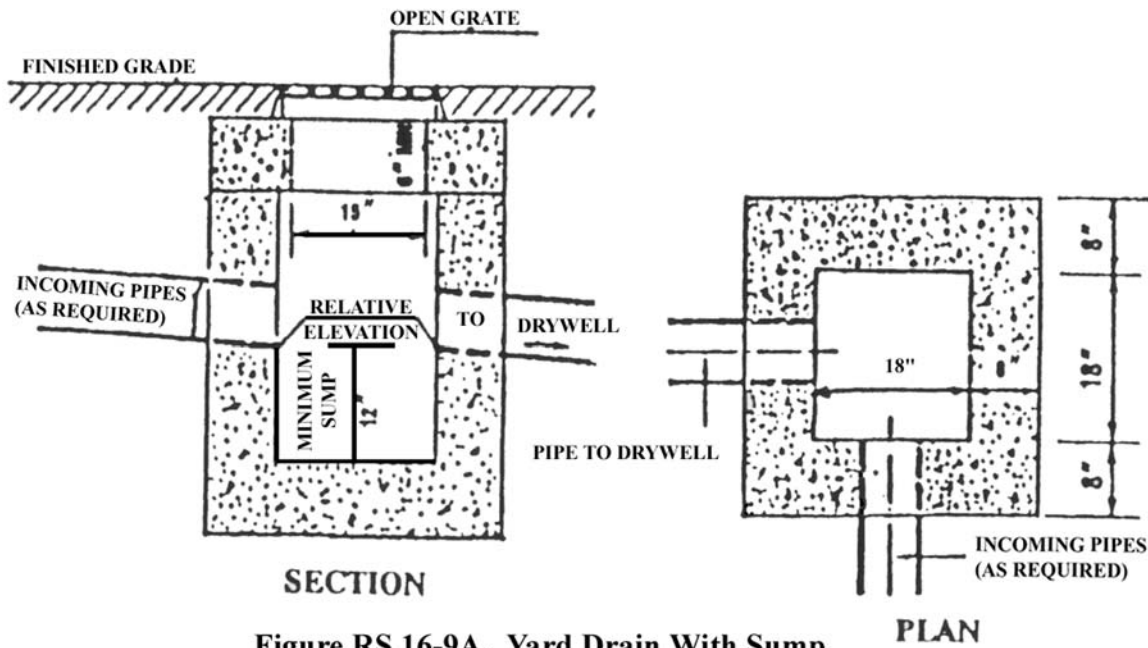

Figure RS 16-9A. Yard Drain With Sump.

(2) If a drywell is used in combination with one or more other methods of storm water disposal pursuant to subparagraph (e) of paragraph two of subdivision (c) of section P110.2 of this reference standard, the size of such drywell shall be determined by the percentage of the storm water such drywell shall dispose.

(3) The construction of drywells shall be subject to controlled inspection.

(4) Drywells shall be located at least five feet from all lot lines and ten feet from all foundations or walls existing on the date of application for a building permit or proposed under the application to construct the drywell.

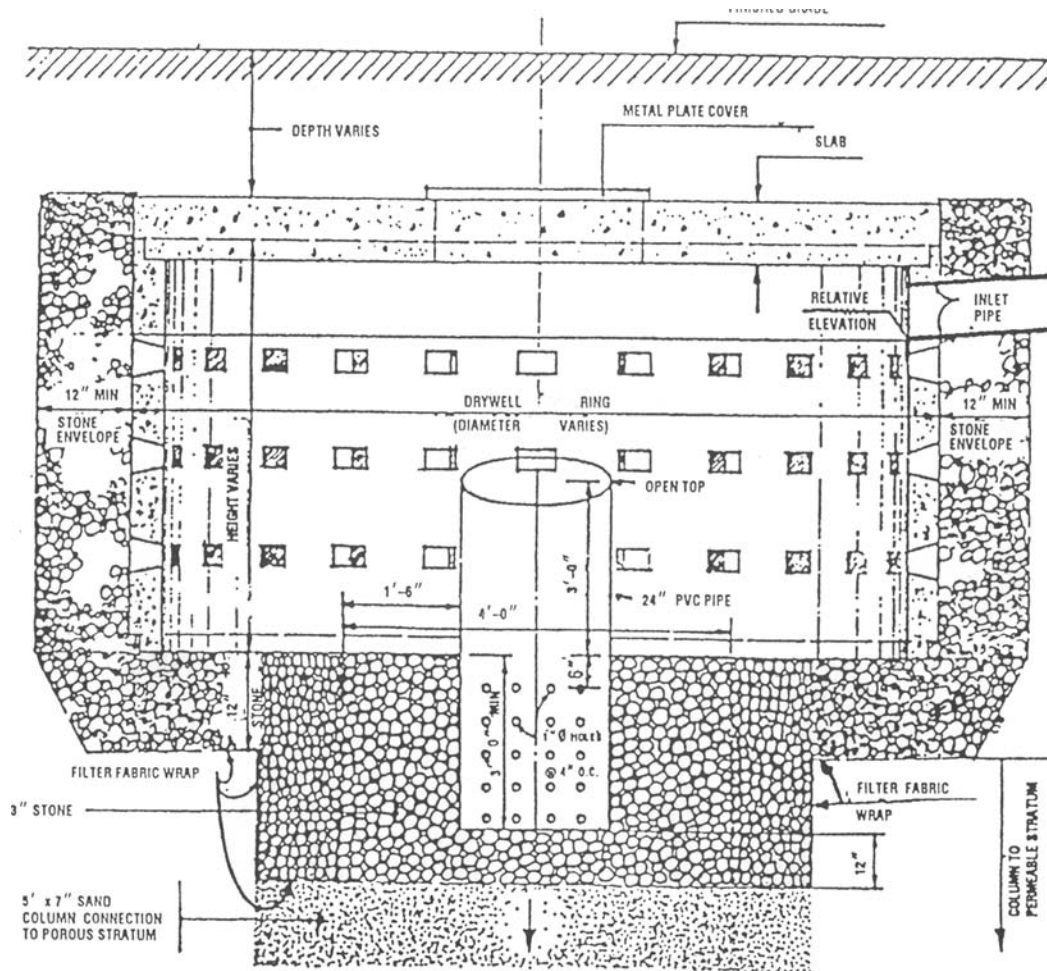

Figure RS 16-9B. Detail of Dry Well With Sand Column.

Reference Standard 16

(5) Notwithstanding the provisions of sections 27-663 and 27-664 of this code, at least one boring and one test pit shall be made at the approximate site of each contemplated drywell.

(6) The storage volume of the drywell shall be measured two feet above the level of the water table, as determined by the test pit at the site of the drywell.

(7) A grit chamber shall be included as part of all drywell systems. It shall be constructed in accordance with figure RS 16-9A.

(8) If the boring and test pit disclose that the drywell is located within or underlaid by impermeable soil, it shall be constructed in accordance with figure RS 16-9B.

(9) If the drywell is underlaid by permeable soil, it shall be constructed in accordance with figure RS 16-9B, except that the sand column to permeable soil may be omitted.

**Local Law 103-1989; Local Law 7-1974*

Section P111.0 Indirect Waste Piping

P111.1 Indirect Waste Required.-

(a) Indirect waste connections to the building drainage system shall be provided where specifically required in this reference standard and for all plumbing fixtures, appliances, and devices where the backing up of waste water or sewage from the drainage system would permit either of the following:

(1) The contamination of food, drinks, or utensils used

for the preparation or serving of foods.

(2) The contamination of surgical and medical equipment.

(b) Wastes from the following fixtures, devices, appliances, or apparatus shall discharge to the building drainage system through indirect wastes that conform to the material, trap, and drainage pipe sizing requirements of this reference standard.

(1) **FOOD HANDLING DEVICES.**-Establishments engaged in the storage, preparation, selling, servicing, processing, or otherwise handling of food shall have the waste piping from all refrigerators, ice boxes, walk-in freezers, cooling or refrigeration coils, steam tables, egg boilers, coffee urns, or similar enclosed equipment discharge indirectly into a water supplied sink or receptor. Culinary and open sinks shall be directly connected to the drainage system.

(2) **LAUNDRY WASHERS AND EXTRACTORS.**-Laundry washers, extractors, and similar equipment shall have the waste water discharge indirectly into a water supplied sink or receptor.

(3) **DRAINS AND OVERFLOWS.**-Indirect waste connections shall be provided for drains, overflows, or relief pipes from the water distribution system.

(4) **STERILIZERS.**-Stills, sterilizers, and similar appliances, devices, or apparatus that require water and waste connections and are used for sterile materials shall be indirectly connected.

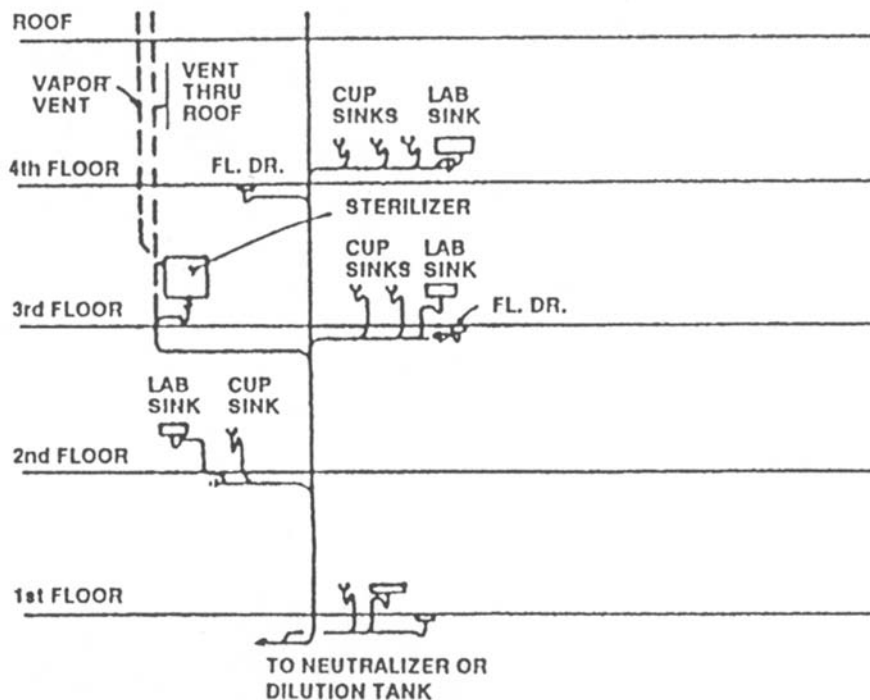

Note:

No venting if each branch to stack has 10 fix. units or less and is less than 30'-0". If branch is over 30'-0" installation shall be as shown on RS 16-11.

Figure RS 16-10. Acid Drainage for Buildings Four Stories or Less.

Reference Standard 16

(5) **DRIPS OR DRAINAGE OUTLETS.**-Appliances, devices, or apparatus not regularly classed as plumbing fixtures, but which have drips or drainage outlets, may be drained by indirect waste pipes.

(6) **WASTE DISCHARGING CLEAR WATER.**-

Expansion tanks, cooling jackets, sprinkler systems, or similar devices that waste clear water only shall discharge into the building storm or sanitary drainage system through an indirect waste.

(7) **SWIMMING POOLS.**-Pipes carrying waste water from swimming or wading pools, including pool drainage, backwash from filters, or water from scum gutter drains, shall be installed as indirect wastes. Circulation pumps may be utilized to lift waste water when the waste line is below the sewer grade.

(8) **PRESSURE TANKS, BOILERS AND RELIEF VALVES.**-The drains from pressure tanks, boilers, relief valves, and similar equipment shall be connected to the drainage system through indirect wastes.

(9) **REFRIGERATORS.**-Each indirect waste pipe from a refrigerator or equipment used for storage of food shall discharge into a receptacle through an air break and, in no instance, shall the indirect waste be trapped ahead of the air break. The maximum developed length of piping between the outlet and the air break shall be 2 ft.

(c) The air break for the indirect waste shall be provided by terminating the open end of the pipe at least 1 in. above the flood level rim of the receiving fixture or receptacle.

P111.2 Common Indirect Wastes.-The wastes from drinking fountains, bar sinks, soda fountains, and similar fixtures may be connected to a common indirect waste stack or header, provided each fixture connected thereto is properly trapped.

P111.3 Venting.-No vents need be provided for the traps of fixtures that are connected to indirect waste piping. Indirect wastes exceeding 100 ft. in developed length, except for indirect wastes from show case refrigerators, which shall not exceed 25 ft. in developed length, shall be extended through the roof or outside wall independent of vents for the regular sanitary system, and they shall terminate as required for sanitary vents.

P111.4 Sizing.-Indirect wastes shall be sized in accordance with the requirements of the direct waste system on the basis of fixture units only. Developed length shall not apply in determining pipe size.

P111.5 Receptors or Sumps.-

(a) **Installation.**-

(1) Waste receptors or sumps serving indirect waste pipes shall not be installed in any toilet room, unless installed in a separate compartment, nor in any inaccessible or unventilated space.

(2) All plumbing receptors receiving the discharge of

indirect waste pipes shall be of such shape and capacity as to prevent splashing or flooding.

(3) Standpipe receptors for automatic clothes washers shall be installed in one of the following ways:

a. The standpipe receptor shall be individually trapped and vented, the trap shall not be installed below the floor, and the standpipe shall extend not more than 30 in. nor less than 18 in. above the trap weir.

b. The standpipe receptor shall be installed in the grating of a floor drain that shall be tapped to receive the standpipe, and the floor drain size shall be predicated on either the discharge rate of the automatic clothes washer or the floor area to be drained, whichever is greater.

(b) **Strainers and baskets.** Every indirect waste receptor shall be equipped with a removable basket or a beehive strainer not less than 4 in. in height. Floor drains receiving an indirect waste discharge need not have dome strainers.

(c) **Domestic or culinary fixtures prohibited as receptors.** No plumbing fixture that is used for domestic or culinary purposes shall be used to receive the discharge of an indirect waste pipe, except that in a dwelling a kitchen sink may be used as the receptor for a dishwasher, and a laundry tray may be used as the receptor for a clothes washing machine.

P111.6 Condensers and Sumps.-No steam pipe shall connect to any part of a drainage or plumbing system, nor shall any water above 150 degrees F be discharged into any part of the drainage system, except that 180 degrees water may be discharged as permitted herein from a commercial dishwasher or laundry. Such pipes, except from the dishwasher, shall be connected by discharging into an indirect waste receptor connected to the drainage system.

Section P112.0 Special and Miscellaneous Waste Piping

P112.1 Industrial Wastes.-Industrial wastes from abattoirs, chemical plants, metal platers, dye works, and similar wastes may not be discharged to a sewer system without an industrial waste permit of the department of public works, except as hereinafter provided.

P112.2 Chemical Wastes.-

(a) No corrosive liquids, acids, strong alkalis, or other chemicals that might destroy or damage the drain, soil, waste, or vent pipes, or that might create noxious or dangerous fumes, shall be discharged into the regular drainage systems until brought within permitted concentrations by treatment.

(b) Such chemicals shall discharge through an independent sanitary drainage system to a dilution or neutralizing device as described in section P105.0 or through some other means of disposal designed by an architect or engineer, subject to the approval of the commissioner and of any other agency or agencies

Reference Standard 16

having jurisdiction.

(c) Chemical waste and vent piping shall be of materials resistant to the corrosive action of chemical fumes in accordance with section P102.4.

(d) The size of the vent and drainage piping shall meet the requirements for sanitary vent and drainage systems in sections P108.0 and P109.0.

(e) All traps in an acid waste system shall have a deep seal.

(f) The acid drainage system shall consist of a waste and a vent stack. In a building where acid drainage systems are provided to serve fixtures, drains, and/or equipment on four floors or less and have no horizontal branch from the waste stack exceeding 30 ft. developed length to the farthest fixture, the waste stack can serve as a wet vent and no branch venting shall be required. See Figure RS 16-10 for typical installation.

(g) Acid dilution or neutralization sumps may be located directly adjacent to, or beneath, each acid sink or fixture. The discharge from each individual acid sump shall connect to the sanitary drainage system and the vent shall be treated in the same manner as a sanitary vent.

(h) Where a common acid neutralization sump for several fixtures or stacks is used, it shall be located at

the lowest story above the house drain. A separate acid dilution sump may be used for fixtures on the first floor and below, and the neutralized effluent shall be lifted from the acid dilution sump to the gravity drainage system by pumping. The drain line at the inlet to dilution sump shall be provided with a relief vent at least 2 in. in diameter or 1/2 the diameter of inlet pipe, whichever is greater. The vent shall terminate in the outside air above the roof or connect to an acid system vent stack or stack vent.

(i) Each drainage pipe that extends more than 30 ft. from the stack or has more than ten fixture units discharging into it shall be provided with a vent connection from the vent stack or stack vent to a connection in the drain line installed between the last two fixtures on the drain line and each 30 ft. increment. Also, a relief vent shall be installed in the horizontal branch waste within 4 ft. of the stack. See Figure RS 16-11 for typical installation.

(j) Fixtures such as floor drains, receptors receiving the indirect waste from sterilizers, stills, and drains from other laboratory equipment within the laboratory area may be connected to the acid drainage system, if the fixtures, excluding floor drains, are provided with individual vents, and all of the piping connecting these fixtures of acid resistant material, or when permitted by

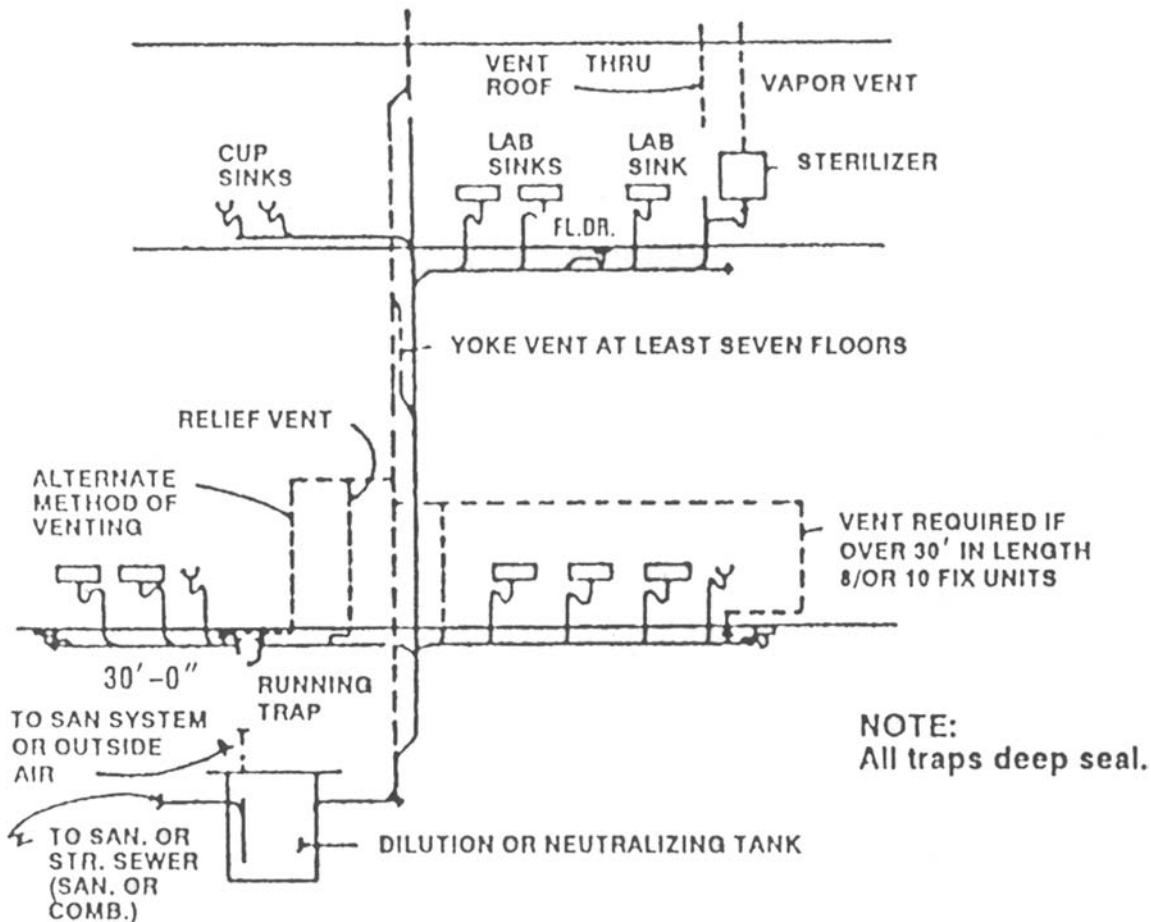

Figure RS 16-11. Acid Drainage for Buildings Over Four Stories.

Reference Standard 16

the commissioner, of cast iron.

(k) Materials shall be in accord with section P102.4(b)(5) and P102.4(c)(3).

P112.3 Flammable Solvents or Oil Wastes.-

Flammable solvents or oil wastes shall be disposed of in accordance with the requirements of section P105.0 or such other method as may be permitted by the department of public works, so that no appreciable amount of flammable or combustible material is discharged to the public sewer in such quantities as to cause an explosive condition. See Figure RS 16-9 for typical installation.

P112.4 Radioactive Wastes.-

Radioactive wastes shall be treated and disposed of by a method designed by an architect or engineer, subject to the approval of the commissioner and of any other agency or agencies having jurisdiction.

***Section P113.0 Individual Sewage Systems**

**Local Law 85-1973*

*****P113.1 Information Required.-**An applicant desiring to construct an individual on site private sewage disposal system shall file a statement certified by a registered architect or licensed professional engineer that there is no available sewer to which the property in question may connect and the distance to the nearest

public sewer. In addition, such construction shall be subject to a site and subsoil evaluation to be performed under the supervision of an employee of the department.

****Local Law 65-1996*

P113.2 Individual Sewage Disposal Systems.-

Where public sewers are deemed not available, the method of sewage disposal shall be designed by an architect or engineer, subject to the approval of the commissioner.

P113.3 Individual Sewage Disposal System (One-and Two-Family Dwellings).-

Where public sewers are deemed not available and a temporary private pumping station or community disposal system is not installed, an individual private sewage disposal system shall be designed by a licensed professional engineer or registered architect and installed in accordance with the requirements of this reference standard and shall be subject to controlled inspection.

P113.4 Housing Development Sewage Disposal

Systems.-When housing developments consisting of more than 15 one-family dwellings or a multiple dwelling of 15 or more dwelling units, are to be built and public sewers are deemed not available, a communal sewage disposal system with street sewers shall be installed in accordance with the drainage plan of the department of water resources.

****TABLE RS 16-21 MINIMUM DISTANCES BETWEEN SEWAGE SYSTEM COMPONENTS AND BETWEEN COMPONENTS AND INCUMBRANCES**

| System components | Building | | Disposal Field | Seepage Pits | Drywell | Water Service Line |
|-------------------|-----------------|---------------|----------------|--------------|---------|--------------------|
| | Foundation wall | Property line | | | | |
| Septic tank | 5 ft. | — | 5 ft. | 5 ft. | — | — |
| Disposal field | 10 ft. | 5 ft. | 20 ft. | 20 ft. | 20 ft. | 10 ft. |
| Seepage pits | 15 ft. | 10 ft. | 20 ft. | 20 ft. | 20 ft. | 10 ft. |
| Drywells | 10 ft. | 5 ft. | 20 ft. | 20 ft. | — | — |

Note-

The seepage pits and drywells may be located contiguous with street line.

***Local Law 103-1989; Local Law 85-1973*

P113.5 General Requirements.-

- (a) The sewage disposal system shall consist of all necessary piping and a septic tank or tanks that discharge into a disposal field or seepage unit, as may be required. Septic tanks shall not discharge into open streams.
- (b) Storm water or ground water shall not be discharged into a septic tank or into the disposal system used to disperse the effluent from the septic tank.
- (c) The use of cesspools is prohibited.
- (d) Slope from seepage unit or distribution pipe invert to lower grades shall not exceed 7.5 percent.
- (e) Backfill surrounding the seepage unit shall be clean, coarse sand as specified.
- (f) Sheathing for seepage unit shall be removed after backfilling.
- (g) All manholes in paved areas shall have a cast iron watertight frame and cover flush with the finished paved surface.
- (h) Slope of lines to septic tank, seepage unit and distributing box shall be not less than 1/4 in. per ft. and shall be shown on the drawings. All piping to these components shall be extra heavy cast iron pipe, not less than 4 in. inside diameter.

- (i) The entire system shall be located in front of the building unless it is not feasible to do so. If placed in a location other than the front, dry piping with trap properly plugged, shall be carried from the house plumbing stack through the front foundation wall to preclude the need for rearranging plumbing when sewers become available; clear access not less than nine feet wide, shall be provided to the disposal system for servicing.
- (j) Sand used in all absorption systems or in fill operations as a medium for subsurface disposal of sewage effluent shall be clean, coarse sand, all passing a 1/4 in. mesh screen, conforming to ASTM specifications C33-1967.
- (k) Stone used in all systems shall be washed and graded, hard durable fragments of granite, trap or other approved rock free from thin or long pieces, screenings, dust, fine stone and foreign substances. The stone shall be well graded between the limits specified.

P113.6 Location.-The minimum permissible distance between the various components of the sewage system and between the components and various

Reference Standard 16

encumbrances are given in Table RS 16-21. All components shall be located within the property line of the premises for which the system is installed.

P113.7 Septic Tanks.-(a) **Construction.**-Septic tanks shall be constructed of material not subject to excessive corrosion or decay and shall be made watertight. Manhole covers and roof shall be designed for a live load of at least 150 psf. Concrete covers when used, shall be reinforced and at least 4 in. thick. Metal septic tanks shall conform to United States Commercial Standard 177-62.

***(b) Manholes.**

(1) The septic tank shall have one manhole situated over the inlet and one over the outlet of the tank. Manholes shall be at least 20 in. square or 24 in. in diameter. The top of the manhole cover shall extend to within 12 in. of final grade to provide easy access for inspection and cleaning. If the septic tank is placed deep in the ground, a chimney or riser shall be provided to raise the manhole cover to the required distance below grade. No person other than a licensed master plumber or a person engaged in sewer services shall remove or open the manhole cover of any septic tank unless otherwise authorized during an emergency by an officer or employee of a city agency.

(2) For purposes of this subdivision, "person engaged in sewer services" shall be defined as one who renders sewer services, including but not limited to installing, altering, repairing, cleaning and pumping sewers, septic

tanks and cesspools, as a part of one's regular business or employment.

**Local Law 21-1981*

(c) Capacity.

(1) Minimum rated capacity of septic tanks shall be in accordance with Table RS 16-22, and shall be predicated upon the 24-hr. sewage flow under normal conditions, plus an allowance of approximately 20 percent for sludge accumulation.

(2) In a tank of more than one compartment, the inlet compartment shall have a capacity of at least two-thirds of the minimum required tank capacity prescribed in Table RS 16-22.

(d) Design.-The concrete tank shall have a water surface at the flow line that is rectangular in plan with the length at least twice the width but no more than three times the width (Figure 16-12A). For steel tanks use 5 ft. diameter (Figure 16-12B).

**** Figure RS 16-12A Typical Concrete Septic Tank**

***Local Law 85-1973*

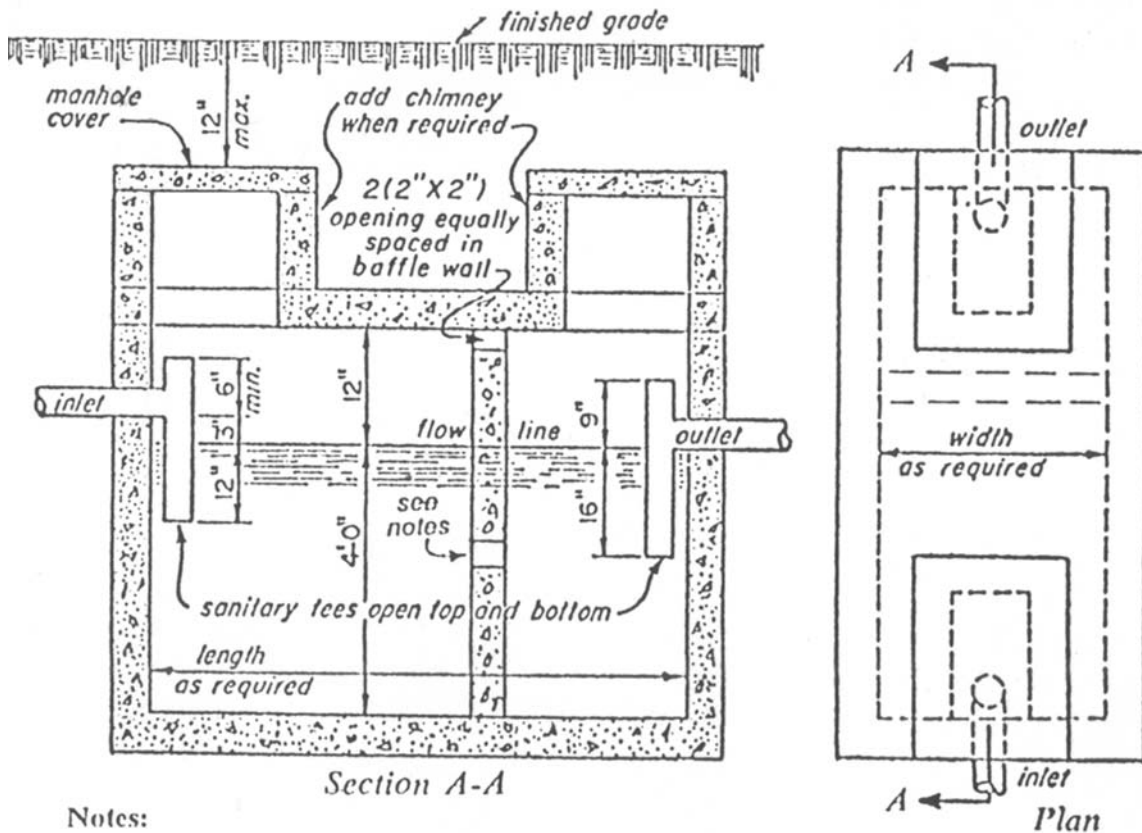

Notes:

1. Interior baffle wall required in all tanks over 9 feet in length.
2. Slot 4" wide by 16" long or two 6" diameter holes at 18" centers.

Reference Standard 16

****TABLE RS 16-22 MINIMUM CAPACITY OF SEPTIC TANKS**

| Type of Dwelling | Number of Bedrooms | Minimum Capacity of Tank to Flow Line, Including Sludge Accumulation (Gallons) |
|------------------|--------------------|--|
| 1 Family | 2 | 750 |
| 1 Family | 3 | 900 |
| 1 Family | 4 | 1,000 |
| 1 Family | 5 | 1,250 |
| 1 Family | 6 | 1,500 |
| 2 Family | 4 | 1,500 |
| 2 Family | 5 | 1,750 |
| 2 Family | 6 | 2,000 |
| 2 Family | 7 | 2,250 |
| 2 Family | 8 | 2,500 |

Note-

If there is an expansion attic: (a) without bathroom add one additional bedroom, (b) add two additional bedrooms, if bathroom is included. Rate: 250 gallons for each additional bedroom.

****Local Law 85-1973**

P113.8 Distribution Box.-A distribution box shall precede all subsurface disposal fields. The distribution box is the chamber into which the septic effluent discharges and from which the sewage enters the subsurface disposal field lines. The box shall be of concrete or steel. If steel, it shall be 12-gage minimum, bituminous-coated in accordance with Commercial Standard 177 of 1962. Floor area of box should be as small as practical in order to provide a maximum head of sewage for equal distribution to all outlet lines. Top of box shall be at least 9 inches above the invert of the

outlet lines. A baffle at the inlet shall be provided to prevent "short circuiting" of flow. The walls of the box shall be high enough so that the cover will be within 12-inches of the finished grade. All outlet inverts shall be set one inch below the inlet invert. Lines from distribution box to disposal field shall be not less than 4 inches inside diameter and shall be laid with tight joints on a uniform slope not less than 1/8 inch per foot.

*****P113.9 Soil Percolation Tests.** -Soil percolation tests shall be performed at the site of a proposed individual on site private sewage disposal system installation to determine the suitability of the soil and site. Such test shall be performed under the supervision of an employee of the department as well as subject to controlled inspection. The result of the percolation tests shall be filed on forms provided by the department, stating the suitability of the site and the capacity of the subsoil for the proposed use.

*****Local Law 65-1996**

P113.10 Seepage Units.-(a) **Capacity.**-The liquid capacity (volume below inlet line) of seepage units shall be at least twice that of the septic tank, as prescribed in Table RS 16-22. In addition, sufficient wall area shall be provided to permit the liquid wastes to leach into the soil without overflowing. Effective absorption area, i.e., the wall area at the outer circumference of the annular stone for any type of dwelling shall be computed in accordance with the Table RS 16-23A or Table RS 16-23B.

**** Figure RS 16-12B Typical Metal Septic Tank**

****Local Law 85-1973**

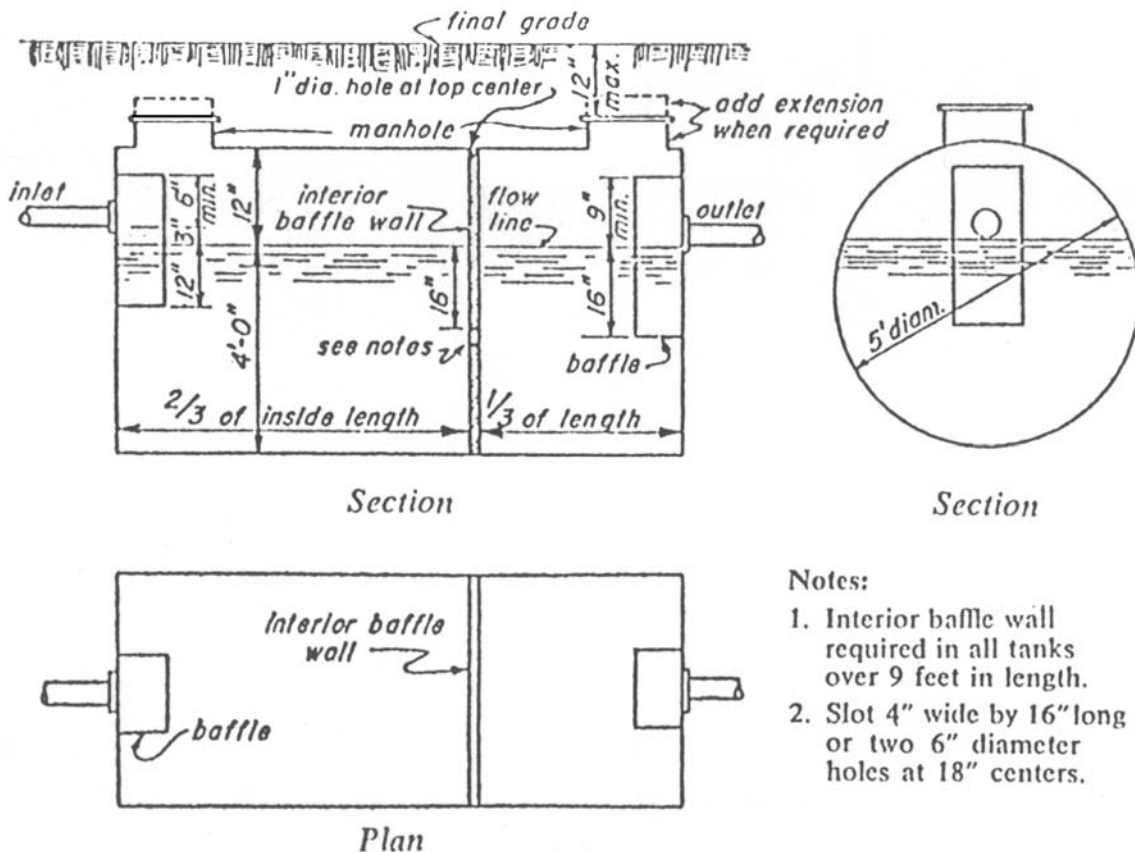

Notes:

1. Interior baffle wall required in all tanks over 9 feet in length.
2. Slot 4" wide by 16" long or two 6" diameter holes at 18" centers.

Reference Standard 16

****TABLE RS 16-23A DESIGN DATA FOR ABSORPTIVE CAPACITY OF DISPOSAL FIELD AND SEEPAGE PITS^a**

| Effluent Allowance Rate of Seepage Unit in gallons per square foot of effective absorptive area per day | | |
|---|--|--------------------------|
| Percolation Rate | | |
| Percolation Test rate in minutes for water to fall 1 inch | Disposal Field Trenches (bottom of trenches) | Seepage Pits (wall area) |
| 2 or less | 3.2 | 4.3 |
| 5 | 2.4 | 3.2 |
| 10 | 1.7 | 2.3 |
| 30 | 0.8 | 1.1 |
| 60 (not recommended) | 0.4 | 0.6 |
| Over 60 (not suitable) | Obtain special approval of the commissioner. (Use special design by an architect or engineer, subject to the approval of the commissioner.) | |

^a For one- or two-family dwellings table RS 16-23B shall be used.

Notes-

Volume of sewage to be disposed of should be equal to the 24 hr. sewage flow.

No portion of the field shall be installed under any pavement or any area where there will be vehicular traffic or parking.

****Local Law 85-1973**

****TABLE RS 16-23B DESIGN DATA FOR ABSORPTIVE CAPACITY OF DISPOSAL FIELD AND SEEPAGE PITS**

| Type of Dwelling | Number of Bedrooms | Minimum Capacity of Field and/or of Pit to Flow Line |
|------------------|--------------------|--|
| 1 Family..... | 2 | 750 |
| 1 Family..... | 3 | 900 |
| 1 Family..... | 4 | 1,000 |
| 1 Family..... | 5 | 1,250 |
| 1 Family..... | 6 | 1,500 |
| 2 Family..... | 4 | 1,500 |
| 2 Family..... | 5 | 1,750 |
| 2 Family..... | 6 | 2,000 |
| 2 Family..... | 7 | 2,250 |
| 2 Family..... | 8 | 2,500 |

Notes-

Add 250 gallons for each additional bedroom. To compute peripheral wall area in sq. ft. for gravel envelope of pits, divide above minimum capacity by 4.3.

To compute area required for disposal field in sq. ft. divide above minimum required capacity by 1.15.

****Local Law 85-1973**

Ref

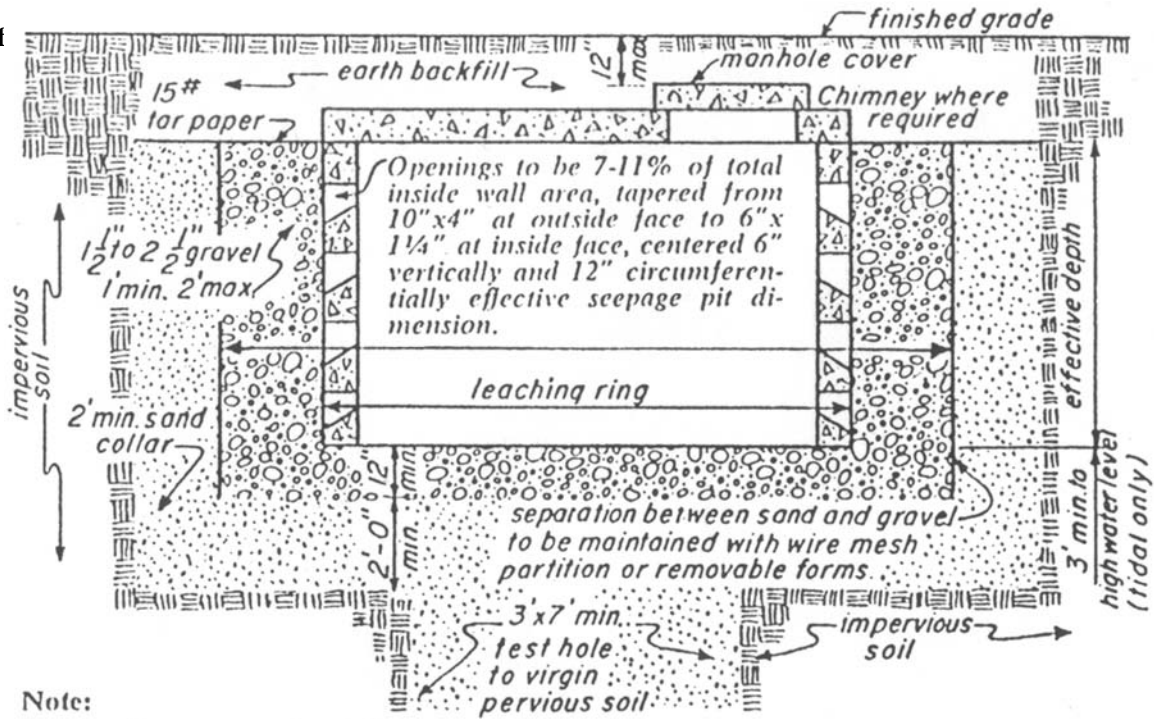

Note:
Sand collar must make full contact with test hole.

(b) **Construction.**-The seepage unit shall be structurally sound. The piping from the septic tank to the unit shall have tight joints. The general construction arrangement shall be in accordance with Figure RS 16-13A or RS 16-13B.

** Figure RS 16-13A Absorption Type System
**Local Law 85-1973

** Figure RS 16-13B Absorption Type
**Local Law 85-1973

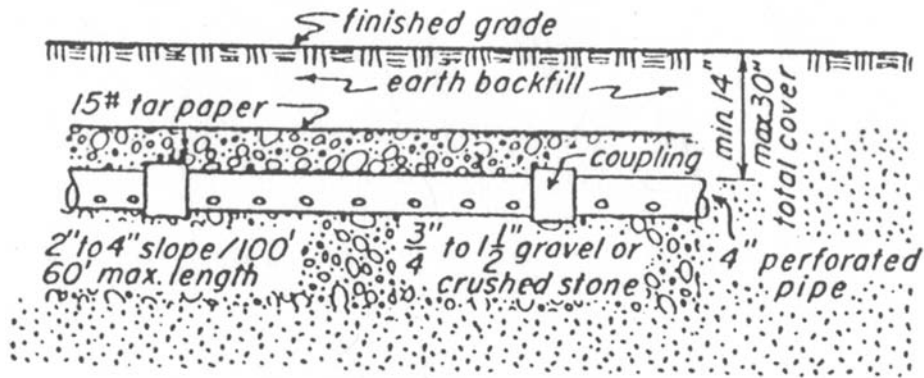

Disposal Field Details

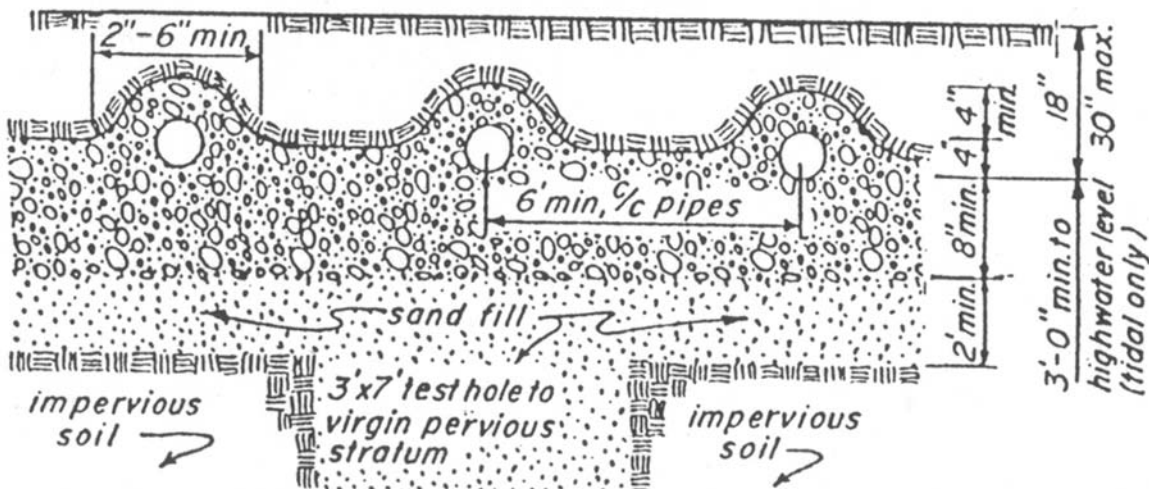

Reference Standard 16

(c) No disposal system shall extend into the water table thereby causing a direct discharge of effluent into the said ground water table. However, in tidal areas, the base of the seepage units or distribution pipes in a field shall be at least 3 feet above the highest water level encountered in the excavated test pit.

P113.11 Subsurface Disposal Field.-

(a) **General.**-Each disposal field shall have at least two outlet distribution lines from the distribution box. The field shall be in an open area, at least 20 ft. from the outer surface of any tree trunk. No portion of the field shall be installed under any pavement or any area where there will be vehicular traffic or parking.

(b) **Construction.**-An absorption-type disposal field, Figure RS 16-13B, may be used in locations wherever an impervious soil stratum overlays a pervious stratum and a seepage unit is not feasible or desired. Septic tank effluent is conducted to a distribution box and thence through the system of perforated pipes for dispersal over the bed of crushed stone or gravel and sand of the required area. This bed of pervious material, overlaying the natural unsatisfactory impervious soil, together with the column of sand (test hole) located within the area of the field, previously prepared and tested, serves as the media through which the septic tank effluent finds its way to the underlying natural pervious soil for eventual subsurface disposal. The allowable 24-hour rate of septic tank effluent application per square foot of field surface shall be at the maximum rate of 1.15 gallons. Lines leading from the distribution box to the head end

of the disposal field shall be extra heavy cast iron pipe not less than 4 in. inside diameter, having tight joints. All distribution lines in the disposal field shall be approved perforated pipe at least 4 in. inside diameter. These lines shall have a uniform slope, 2 in. to 4 in. per 100 ft. with a minimum spacing of 6 ft. on centers. All distribution lines shall be of equal length not over 60 ft. long to provide uniform distribution of the effluent and shall have a minimum cover of 14 in. on the pipe. Wherever it may be necessary to construct a large percentage of the field lines with cover in excess of 30 in., other designs using seepage units if possible should be considered.

(c) **Filter material.**-The lines shall be surrounded by crushed stone or gravel ranging in size from 3/4 in. to 1 1/2 in. from a level at least 8 in. below the bottom of the pipe to a level at least 4 in. above the top of the pipe. The upper surface of the stone shall be covered with a layer of impervious tar paper, minimum weight 15 pounds, before placing the earth backfill, in order to prevent soil from penetrating into the filter material and subsequently into the pipes.

(d) **Distance requirements.**-Disposal fields shall be installed in accordance with the requirements of Table RS 16-24.

P113.12 Maintenance.-A chart, showing the location of the septic tank and the field system for a building, shall be kept at a suitable location within the building. This chart shall also contain brief inspection and maintenance instructions for the septic tank.

****TABLE RS 16-24 LIMITING DIMENSIONS OF DISPOSAL FIELD COMPONENTS**

| Component | Limit |
|--|---|
| Individual lines, maximum length | 60 ft. |
| Individual lines, lengths..... | All of equal length |
| Field distribution pipe, minimum diameter..... | 4 in. |
| Field distribution pipe, maximum slope | 4 in. per 100 ft. length |
| Field distribution pipe joints | Tight (no spaces) as required by type of pipe |
| Trench or bed bottom, minimum depth | 18 in. |
| Trench or bed bottom, average depth | Not more than 30 in. |
| Trench or bed bottom, minimum above ground water ... | 2 ft. |
| Trench bottom, minimum width (percolation rate of 2 minutes or less) | 18 in. |
| Trench bottom, minimum width (percolation rate of 5 to 10 minutes) | 24 in. |
| Trench bottom, maximum width for other more impervious soils | 30 in. |
| Trench or bed, minimum separation between | 3 times trench width but not less than 6 ft. |

****Local Law 85-1973**

Section P114.0 Hospital and Institutional Plumbing

P114.1 General.-Hospital and institutional plumbing systems shall comply with all applicable plumbing requirements, except as specifically modified

in this section.

P114.2 Definitions for Special Hospital Fixtures and Equipment.-

Reference Standard 16

ASPIRATOR.-A fitting or device that is supplied with water or other fluid under positive pressure. The water or other fluid passes through an integral orifice, or constriction, causing a vacuum. Aspirators are often referred to as "suction" apparatus, and are similar in operation to an ejector fitting.

AUTOPSY TABLE.-A fixture or table used for the post-mortem examination of a body. (See Section P107.0 for method of connecting water supply.)

BEDPAN HOPPER (CLINIC SINK).-A fixture used to flush the contents of bedpans and meet the design requirements of Section P114.3(a).

BEDPAN STEAMER.-A fixture used for sanitizing bedpans or urinal bottles by direct application of steam.

BEDPAN WASHER.-A fixture designed to wash bedpans and to flush the contents into the sanitary drainage system. It may also be used for sanitizing bedpans and urinals with steam or hot water.

BEDPAN WASHER DEVICE.-A device used for cleansing bedpans. It is supplied with hot and/or cold water, and is located adjacent to a water closet or clinic sink or installed in the discharge piping of the flush valve.

BEDPAN WASHER VENT.-A local vent that is a vertical pipe to which connections are made from the fixture side of traps and through which vapor and/or foul air may be removed from the bedpan washer.

CLINIC SINK.-See "Bedpan Hopper."

STERILIZER, BOILING TYPE.-A fixture (nonpressure vessel) used for boiling instruments, utensils, and/or other equipment for the purpose of disinfection. Some devices are portable, others are connected to the plumbing system.

STERILIZER, PRESSURE (AUTOCLAVE).-A fixture (pressure vessel) designed to use steam under pressure for sterilizing.

STERILIZER, PRESSURE (INSTRUMENT WASHER-STERILIZER TYPE).-A fixture (pressure vessel) designed to both wash and sterilize instruments during the operating cycle of the fixture.

STERILIZER VENT.-A separate pipe or stack, indirectly connected to the building drainage system at the lower terminal. The pipe or stack receives the vapors from nonpressure sterilizers or the exhaust vapors from pressure sterilizers and conducts the vapors directly to the outer air. (Sometimes called a vapor, a steam, an atmosphere or an exhaust vent.)

STERILIZER, WATER.-A fixture (pressure vessel) designed for sterilizing water and storing this sterile water.

STILL.-A device used for distilling liquids.

P114.3 Requirements for Special Hospital Fixtures and Equipment.-Bedpan hoppers (clinic sinks), bedpan washers, and similar fixtures and

equipment shall be provided for disposal of bedpan contents and cleansing and disinfecting bedpans. All such fixtures and equipment shall be subject to the following requirements:

(a) Bedpan hoppers (clinic sinks).-Such fixtures shall have an integral trap in which the upper portion of a visible trap seal provides a water surface. The fixture shall be designed so as to permit complete removal of the contents by siphonic and/or blow-out action, and to reseal the trap in a single flushing operation. A flushing rim shall provide water to cleanse the interior surface. The fixtures shall have flushing and cleansing characteristics similar to a water closet.

(b) Prohibited use of clinic sinks and service sinks.-A clinic sink shall not be used as a janitor's service sink. A janitor's service sink shall not be used for the disposal of urine, fecal matter, or other human wastes.

(c) Special requirement for ice manufacture and storage.-No machines for manufacturing ice, or any device for handling or storing ice, shall be located in a room containing a bedpan hopper, clinic sink, bedpan washer, or similar fixture. Machines for manufacturing ice, or devices for handling or storing ice intended for either human consumption or packs, shall be located in a clean utility room, a floor pantry, a diet kitchen, or in other similar locations.

(d) Sterilizers.

(1) DESCALING PROHIBITED.-The interior of water sterilizers, stills, or similar equipment shall not be descaled or otherwise treated by acid or other chemical solutions while the equipment is connected to the water and/or drainage system.

(2) STANDARD.-New pressure sterilizers and pressure type instrument washer-sterilizers hereafter installed shall conform to ASME boiler and pressure vessel code, 1962, section VIII and shall bear a data plate clearly visible at all times indicating conformity to such standards.

(3) STERILIZER PIPING.-All sterilizer piping and/or devices necessary for the operation of sterilizers shall be accessible for inspection and maintenance.

a. **Steam supply.**-Steam supplies to sterilizers, including those connected by pipes from overhead mains or branches, shall be drained to prevent any excess moisture from reaching the sterilizer. The condensate drainage from the steam supply shall be discharged by gravity.

b. **Condenser.**-Pressure sterilizers shall be equipped with a means for condensing exhaust steam vapors.

c. **Gas fired equipment.**-Gas fired equipment or apparatus requiring either water or drainage connections, or both, shall comply with the requirements of this reference standard and the applicable provisions of the building code.

P114.4 Plumbing in Mental Hospitals.-Special consideration shall be given to the design and installation of plumbing fixtures in mental hospitals. No

Reference Standard 16

pipes or traps shall be exposed and all fixtures shall be securely bolted through walls.

P114.5 Number of Plumbing Fixtures.-The minimum number of fixtures for hospital and institutional occupancy shall be in accordance with Table RS 16-25, Fixtures for Hospitals and Institutions.

P114.6 Drainage and Venting.-

(a) Ice storage chest drains.-Each drain serving an ice chest or box shall discharge into an indirect waste receptor. Each drain shall discharge through an air break above the receptor. The end of the drain shall be covered with a removable screen of not* at least 10 mesh per in. or with a flap valve.

(b) Bedpan washers and clinic sinks.-Bedpan washers and clinic sinks shall be connected to the sanitary drainage system and vented in accordance with the requirements for water closets, except that bedpan washers with vapor vent connections shall require additional vapor vents.

*As enacted but probably "net" is intended.

P114.7 Sterilizer Wastes.-

(a) Indirect wastes required.-Each sterilizer shall be provided with an individual and separate indirect waste, and with an air break having a diameter at least twice that of the waste tailpiece. The upper rim of the receptor, funnel, or basket type fitting shall be at least 2 in. below the vessel or the piping, whichever is lower. Except as provided in (b) below, a "P" trap shall be installed on the discharge side of, and immediately below, the waste connection serving each sterilizer.

(b) Floor drain required.-In all rooms containing the recessed or concealed portions of sterilizers, the entire floor area shall be drained and at least one floor drain shall be installed. The floor drain waste and trap shall have a minimum diameter of 3 in. It shall receive the drainage from at least one sterilizer to assure maintenance of the floor drain trap seal. No individual sterilizer waste trap shall be required on this type of installation.

TABLE RS 16-25 MINIMUM NUMBER OF FIXTURES FOR HOSPITALS AND INSTITUTIONS

| Type of Building Occupancy | Type of Fixtures | | | | | |
|---|---|-------------------------|-------------------------|-----------------------|----------------------------|--|
| | Water Closets | Urinals | Lavatories | Bathtubs or Showers | Drinking Fountains | Other Fixtures |
| Institutional—other than hospitals or penal institutions (on each occupied story) | 1 for ea. 25 men 1 for ea. 20 women | 1 for each 50 men | 1 for each 20 persons | 1 for each 10 persons | 1 for each 50 persons | In accordance with the hospital code of the city of New York |
| Hospitals – general | See table RS 16-5 | | | | | |
| Hospital – employees | See Public Facilities | | | | | |
| Institutional – prisoners | 1 in each cell | | 1 in each cell | 1 in each cell | 1 on each cell block floor | 1 slop sink per floor |
| | 1 in each exercise room | 1 in each exercise room | 1 in each exercise room | | 1 in each exercise area | |
| Institutional – employees and public Facilities | See Table RS 16-5 | | | | | |
| Nursing homes | in accordance with the nursing home code of the city of New York. | | | | | |

(c) Bedpan steamers, additional trap required.-A trap with a minimum seal of 3 in. shall be provided in a bedpan steam drain located between the fixture and the indirect waste connection.

(d) Pressure Sterilizer.-Except when an exhaust condenser is used, a pressure sterilizer chamber drain may be connected to the exhaust drip tube before terminating at the indirect waste connection. If a vapor trap is used, it shall be designed and installed to prevent moisture being aspirated into the sterilizer chamber. The jacket steam condensate return, if not connected to a gravity steam condensate return, shall be separately

and indirectly wasted. If necessary to cool a high temperature discharge, a cooling receiver, trapped on its discharge side, may serve as the fixture trap.

(e) Exhaust condensers.-Drain from exhaust condensers shall be installed with an indirect waste as prescribed in this code. If such condensers are used on pressure sterilizers, the chamber drain shall have a separate indirect waste connection.

(f) Water sterilizer.-All water sterilizer drains, including tank, valve, condenser, filter and cooling, shall be installed with indirect waste.

(g) Pressure type instrument washer-sterilizer.-The

Reference Standard 16

pressure type instrument washer-sterilizer chamber drain and overflow may be interconnected. They may also be interconnected with the condenser. The indirect waste shall comply with the provisions of this reference standard.

P114.8 Vapor Vents.-

- (a) **Vent material.**-Material for sterilizer, vapor, and exhaust vents shall be as required by Section P102.4.
- (b) **Vent connections prohibited.**-Connections between vapor vents serving bedpan washers, sterilizing apparatus, and/or normal sanitary systems, are prohibited. Only one type of apparatus shall be served by a given type vent.
- (c) **Bedpan Vents and stacks.-**
 - (1) **BEDPAN WASHERS.**-Bedpan washers shall be vented to the outer atmosphere above the roof by means of bedpan vents. The vent for a bedpan washer shall be at least a 2 in. diameter pipe. A bedpan vent serving a single bedpan washer may drain to the fixture served.
 - (2) **MULTIPLE INSTALLATIONS.**-Where bedpan washers are located above each other on more than one

floor, a bedpan vent stack may be installed to receive the bedpan vent on the various floors. The connections between a bedpan washer vent and a bedpan vent stack shall be made by using tee or tee-type sanitary pattern drainage fittings, installed in an upright position. See Table RS 16-26 for vent sizing.

- (3) **TRAP REQUIRED.**-The bottom of the bedpan vent stack, except when serving only one bedpan washer, shall be drained by means of a trapped connection discharging indirectly into the plumbing sanitary drainage system. The trap and waste shall be at least 2 in. in size.
- (4) **TRAP SEAL MAINTENANCE.**-A water supply of at least 1/4 in. tubing shall be taken from the flush supply of each bedpan washer on the discharge or fixture side of the vacuum breaker, trapped to form at least a 3 in. seal, and connected to the local vent on each floor. The water supply shall be so installed as to provide a supply of water to the local vent stack for cleansing and drain trap seal maintenance each time a bedpan washer is flushed.

**TABLE RS 16-26
STACK SIZES FOR BEDPAN STEAMERS AND BOILING TYPE
STERILIZERS AND NUMBER OF CONNECTIONS PERMITTED**

| Stack Size (in.) | No. of Connections Permitted | | |
|------------------|------------------------------|-----|---|
| | Connection Size (in.) | | |
| | 1 1/2 | | 2 |
| 1 1/2 | 1 | or | 0 |
| 2 | 2 | or | 1 |
| 2 | 1 | and | 1 |
| 3 | 4 | or | 2 |
| 3 | 2 | and | 2 |
| 4 | 8 | or | 4 |
| 4 | 4 | and | 4 |

(d) Pressure sterilizer vent and stacks.-

- (1) **CONNECTIONS.**-In multiple installations of pressure and nonpressure sterilizers, vent connections to the sterilizer (vapor) vent stack shall be made by means of inverted type fittings.
- (2) **DRAINAGE.**-The connection between sterilizer vent and/or exhaust openings and the sterilizer vent stack shall be designed and installed to drain to the funnel or basket-type waste fitting. In multiple installations, the sterilizer vent stack shall be drained separately to the lowest sterilizer funnel or basket-type waste fitting or receptor.

sterilizer vent stack shall be 2 in. when serving a utensil sterilizer, and 1 1/2 in. when serving an instrument sterilizer. Combinations of boiling type sterilizer vent connections shall be based on Table RS 16-26.

(c) **Pressure sterilizers.**-The minimum diameter of sterilizer vent stacks or the vertical stack vent from a single unit shall be 2 in. minimum. Stacks serving combinations of pressure sterilizer exhaust connections shall be sized according to Table RS 16-27.

(d) **Pressure type instrument washer-sterilizer.**-The minimum diameter of a sterilizer vent stack serving an instrument washer-sterilizer shall be 2 in.

(e) **Roof penetration.**-Vent shall be increased in size and extended through the roof in accordance with sanitary venting requirements.

P114.9 Sizing of Sterilizer Vent Stack.-

- (a) **Bedpan steamers.**-The minimum diameter of a sterilizer vent serving a bedpan steamer shall be 1 1/2 in. Multiple installations shall be sized according to Table RS 16-26.
- (b) **Boiler type sterilizer.**-The minimum diameter of a

P114.10 Water Supply.-

(a) **Services.**-All hospitals shall be provided with at least two water service connections. Whenever more

Reference Standard 16

than one street main is available, the connections shall be made to different street mains.

(b) Water supply protection.-The installation of the water supply shall meet all the requirements prescribed in Section P107.0, except as hereinafter provided. (See Table RS 16-28.)

(c) Hot water supply protection.-Hot water supply to patients' showers, therapeutic equipment, and continuous baths shall be provided with control valves automatically regulating the temperature of the water supply to the fixture. The valve shall fail in a closed position when the tempered water supply to the fixture exceeds 110 degrees F.

TABLE RS 16-27 STACK SIZES FOR PRESSURE STERILIZERS AND NUMBER OF CONNECTIONS PERMITTED

| Stack Size (in.) | No. of Connections Permitted | | | | | | |
|---------------------|------------------------------|-----|---|-----|-------|-----|-------|
| | Connection Size (in.) | | | | | | |
| | 3/4 | | 1 | | 1 1/4 | | 1 1/2 |
| 1 1/2 | 3 | or | 2 | or | 1 | | |
| 1 1/2 | 2 | and | 1 | | | | |
| 2 | 6 | or | 3 | or | 2 | or | 1 |
| 2 | 3 | and | 2 | | | | |
| 2 | 2 | and | 1 | and | 1 | | |
| 2 | 1 | and | 1 | and | | | 1 |
| 3 | 15 | or | 1 | or | 5 | or | 3 |
| 3 | | | 1 | and | 2 | and | 2 |
| 3 | 1 | and | 5 | and | | | 1 |

TABLE RS 16-28 FIXTURE WATER SUPPLY PROTECTION^a

| Fixtures | Type of Protection | Remarks |
|--|-----------------------|---|
| Aspirators | Separate water system | _____ |
| Bedpan | | |
| Washers | Vacuum breaker | |
| Washer Hose | Vacuum breaker | Locate 5 ft. above floor |
| Boiler type sterilizer | Air gap | Not less than twice the effective opening of the water supply |
| Exhaust condenser | Vacuum breaker | _____ |
| Pressure type instrument washer-sterilizer | Vacuum breaker | _____ |
| Pressure type sterilizer | Vacuum breaker | _____ |

Note-

^a Where vacuum breakers are used, they shall be installed after the last control valve. See section P107.2 for requirements for other fixtures.

P114.11 Vacuum systems.-

(a) Aspirators, water.-The use of water aspirators is prohibited.

(b) Bottle systems.-Vacuum systems intended for collecting, removing and/or disposing of blood, pus, and/or other fluids shall be protected by bottles (furnished as secondary equipment) installed near the outlet. Each vacuum outlet station shall be equipped so as to prevent fluids other than air from entering the vacuum piping systems.

(c) Central system equipment.-The collecting and/or control tanks in central systems shall be provided with drains for cleaning the tanks. The exhausts from vacuum pumps used in connection with a vacuum system shall discharge separately to the outdoor air above the roof or at such other locations as may be permitted by the Commissioner. The exhaust discharge

shall, in no case, be located so as to cause a hazard to public safety, health or welfare.

***P114.12 Oxygen and Nitrous Oxide Systems.**-Where oxygen and nitrous oxide systems are installed, the piping, outlets, manifolds, manifold rooms, and storage rooms shall be installed in accordance with the requirements of ANSI/NFiPA 99-1987 Standard for Health Care Facilities, as modified and ANSI/NFiPA 50-1985 Bulk Oxygen Systems at Consumer Sites. The alarms for the systems shall comply with Reference Standard RS 17-3 and the requirements of the fire department.

ANSI/NFiPA 99-1987 shall be subject to the following modifications:

Section 4-3.1.4 Amend the initial sentence to read as follows: The central supply system shall be a system of cylinders and necessary supply equipment assembled as described

Reference Standard 16

in either 4-3.1.5 or 4-3.1.6, or a bulk supply system (4-3.1.7) which shall be of the permanently installed type.

Section 4-3.1.10 Add paragraph (b) to read as follows:

(b) The emergency oxygen supply connection shall not be used unless prior Fire Department approval and permits are obtained to store and use the emergency oxygen supply.

Section 4-3.2.2 Amend this section to read as follows:

4.3.2.2 Supply system and storage locations shall comply with 4-3.1.1.2; 4-3.1.1.3; 4-3.1.2.1(a); 4-3.1.2.1(c); 4-3.1.2.1(e); 4-3.1.2.1(g); 4-3.1.2.1(h); 4-3.1.2.1(i); 4-3.1.2.1(j); 4-3.1.2.1(k); 4-3.1.2.1(l); 4-3.1.2.2; 4-3.1.2.3; 4-3.1.3; 4-3.1.5.2; 4-3.1.8.2.

Section 4-4.1.2.1 Add paragraph (j) to read as follows:

(j) The gas content of medical gas piping systems shall be readily identifiable by appropriate labeling with the name of the gas contained. Such labeling shall be by means of metal tags, stenciling, stamping, or with adhesive markers, in a manner that is not readily removable. Labeling shall appear on the piping at intervals of not more than 20 feet and at least once in each room and each story traversed by the piping system. Where supplementary color identification of piping is used, it shall be in accordance with the gases and colors indicated in Compressed Gas Association Pamphlet C-9, Standard Color-Marking of Compressed Gas Cylinders Intended for Medical use in the United States. (1973).

Section 4-4.1.2.3 Add paragraph (g) to read as follows:

(g) Threaded connections using other than taper pipe threads, shall be prevented from loosening through the use of an anaerobic compound or any other method conforming with good engineering practice for such purpose.

**Local Law 12-1982; 1025-88 BCR*

****Section P115.0 Gas Piping**

***Local Law 30-1982*

*****P115.1 General Requirements For Gas Piping.-**

The gas piping system, system testing and appliance installation shall be as required by this section, section C26-1606.1 and section C26-1606.4 (d).

****Local Law 54-1970*

****P115.2 Gas Service Piping Connections.-**

(a) Gas service piping shall be fitted with a gas service line valve, the valve located on the supply side of the meter and service regulator, if a service regulator is required. If a plug type valve is used, it shall be constructed so as to prevent the core from being blown out by the pressure of the gas. In addition, it shall be of a type capable of being locked in the off position by the local gas utility. When the gas service line valve is inside the building, it shall be in an accessible location within 2 ft. of the point where the gas service connection enters the building or at such other location as may be permitted by the commissioner. Where the gas service connection is

installed through a building wall below ground, it shall be protected with a wall sleeve extending at least 4 in. beyond the outer side of the wall and at least 1 in. beyond the inner side of the wall. The sleeve shall be sealed at both ends to prevent the entry of water and gas. Gas service connections, installed through ground slab construction, shall be protected with a floor sleeve sealed at both ends to prevent the entry of water and gas. The sleeve shall extend at least 4 in. above the floor, and shall be installed as specified by the utility company providing the service. It shall terminate at least 4 in. outside the building.

(b) In all high pressure areas, the utility company providing the service may inspect the gas service line valve and regulator in accordance with the code requirements of the state of New York as set forth in 16 NYCRR, Part 255, in addition to the department of buildings in accordance with sections C26-1606.1 and C26-1606.4 (d).

(c) No gas service shall enter a structure at a horizontal distance of less than 10 ft. from the cellar termination of a stairway, nor shall any gas meters or gas regulators be located less than 10 ft. from such stairway termination. Where such services, meters and regulators are separated from the stairway termination by a permanent partition or wall having a fire-resistance rating of at least 1 hr. the foregoing shall not apply. Unless forbidden by other provisions of this code, locations under a stairway are exempt from this requirement.

(d) When the structure is erected on fill or on piles, provision shall be made to preclude possible damage to the gas service piping caused by settlement.

***Local Law 30-1982*

****P115.3 Gas Distribution Pressures.-**No gas distribution piping containing gas at a pressure in excess of 1/2 psig shall be run within a building, except that pressure not exceeding three psig is permitted for the following uses:

(a) commercial use, (b) industrial use; (c) other large volume use in which fuel requirements for boiler room equipment exceed 4000 cubic feet per hour and such large volume use is supplied through separate gas distribution piping to the boiler room. Gas pressure not exceeding 15 psig is permitted for boiler room equipment in excess of 100,000 cubic feet per hour provided the gas distribution piping is installed as provided for in P115.8. The use of pressure in excess of 15 psig shall be permitted for distribution piping provided all of the requirements of P115.8(n) are met.

***Local Law 30-1982*

****P115.4-Gas Regulator And Gas Regulator Vent Outlets.-**Gas meter piping supplying gas to a building at a pressure in excess of 1/2 psig shall be provided with a regulator that will reduce the pressure of the gas to 1/2 psig or less prior to entering the gas distribution

Reference Standard 16

pipng in the building, except where the use of higher pressure is permitted. Where gas distribution pressure in excess of 1/2 psig is permitted, it shall be regulated not to exceed the maximum pressure level as permitted by the code or commissioner.

(a) Inside gas meter piping operating at a pressure in

excess of 15 psig shall comply with the following:

(1) Where such piping is greater than 4-in. in diameter, the meter piping shall be installed in a properly ventilated meter room of 3 hour fire rated construction.

(2) The maximum distance from the service line valve to the regulator shall be limited as follows:

| Service Line Valve Size | Maximum Distance (Linear Feet of Pipe) |
|------------------------------------|---|
| up through 2" pipe size | 4 feet |
| over 2" through 4" pipe size | 8 feet |
| over 4" through 8" pipe size | 15 feet |
| 10" pipe size and larger | 20 feet |

(3) Where these maximum distances cannot be met, the following shall be required:

| Footage (Linear Feet of Pipe) in Excess of Above Requirements | Additional Requirements |
|---|---|
| up to 5 ft..... | The meter room shall have 3 hour fire rating construction and adequate ventilation |
| over 5 ft. through 10 ft | Above requirements plus a combustible gas-detection alarm system |
| over 10 ft. through 15 ft | Above requirements plus controlled inspection by the customer or his representative as specified in section C26-106.3 |
| over 15 ft. through 20 ft | Above requirements plus explosion venting per NFIPA Std. No. 68-1978; or alternative ventilation acceptable to the commissioner and automatic gas shutoff devices |
| over 20 ft..... | Above requirements plus suitable fire protection approved by the commissioner |

For new gas installations made in existing structures, the above requirements shall be used to the extent feasible. Alternate designs may be considered by the commissioner.

(b) When located inside the building, each regulator shall be provided with a vent pipe that leads directly to the outdoor air. The vent pipe shall be sized according to local utility requirements. The vent outlet shall not be located under a window or any opening leading back into the premises or located below any overhang or projection. No gas regulator vent outlet shall be covered over, plugged up, or otherwise obstructed, and all gas vents shall be identified by suitable marking on the outlet on the outside of the building.

Gas appliance pressure regulators requiring access to the atmosphere for successful operation shall be equipped with vent leading to the outdoors, unless constructed or equipped with a vent limiting means to limit the escape of gas from the vent opening in the event of diaphragm failure.

****Local Law 30-1982**

****P115.5 Outside Gas Cut-off.-**

*(a) An outside gas service line valve or other outside emergency shut-off device or method acceptable to the commissioner and fire commissioner shall be installed in every gas service pipe outside the building. If buried, such valve, device or method shall be readily accessible from grade. Every existing service which is being replaced or refurbished shall be provided with such valve, device or method, but in any event, all existing gas services shall be provided with such valve, device or method by January 1, 2020 provided however, all occupancy groups other than J-3 shall be required to be completed by January 1, 2010. The minimum annual rate of installing such valve, device, or method shall be determined by the applicable utility; however, it shall be chosen to ensure timely completion of the program by the date specified herein. The applicable utility shall provide the Fire Department with suitable tools for operation of such emergency shut-off valves, devices or methods. The number of such tools required for

Reference Standard 16

supplying fire department units shall be determined by the fire department. On or before January 31, of each year, the applicable utility shall report to the Department of Buildings and the Fire Department the actual number of emergency shut-off valves installed for the preceding year.

(b) If the outside gas service line valve, emergency shut-off device or method is located below ground, it shall be installed in a protective housing, and a cover, easily identifiable shall be provided for the housing. The cover shall be flush with the surface of the ground and kept clear at all times so as to be accessible for immediate use.

(c) The valve or emergency shut-off device shall be capable of being readily operated by removing the cover of the housing and inserting a portable key or other device over the operating end of the valve or emergency shut-off device.

(d) If the outside gas service line valve is located above ground, it shall be suitably protected to prevent accidental vehicular impact and must be installed in accordance with the code requirements of the state of New York as set forth in 16 NYCRR Part 255.

***Local Law 30-1982*

**Local Law 89-1995*

P115.6 Gas Meter Location.-

(a) When located inside the building, meters shall be located as near as practicable to the point of entrance of the service and, where possible, the meters shall be located in the cellar or basement unless otherwise permitted by the commissioner. The meter location shall be clean, dry, and free of refuse, steam or chemical fumes. Meters shall be adequately protected against extreme cold or heat and shall be readily accessible for reading and inspection. The area in which the meter is located shall be properly ventilated. Notwithstanding the foregoing, outside meter installation shall be permitted in areas where the utility company certifies that dry gas is being distributed.

(b) In a multiple dwelling, no gas meter, other than the replacement of an existing meter shall be located in any boiler room or other room or space containing a heating boiler, in any stair hall, nor in any public hall above the cellar or above the lowest story if there is no cellar. However, in any multiple dwelling where there is an existing gas meter located in any boiler room or other room or space containing a heating boiler, one additional gas meter may be installed in such room or space, provided such additional gas meter is installed adjacent to the existing gas meter and is used in conjunction with the supply of gas for a gas-fired heating boiler or a gas-fired water heater used as a central source of supply of heat or hot water for the tenants residing in such multiple dwelling. Such additional gas meter may be installed only upon the condition that space heaters or hot water appliances in the dwelling units are eliminated.

(c) Gas meter rooms, when provided, shall at all times be kept clear of all rubbish; and shall not be used in any way for storage purposes, including material or equipment of any kind. A legible sign reading "Gas meter room-No storage permitted" shall be permanently and conspicuously posted on the exterior of the meter room door, except that the sign may be posted on the interior of the meter room door in buildings classified in occupancy group J-3. The lettering of such signs shall be of bold type at least one inch in height and shall be properly spaced to provide good legibility. The lettering and background shall be of contrasting colors. Where gas meters and related equipment are not located in a separate room but are located in an open floor area, no combustible material shall be stored or kept within five feet of such equipment; nor shall the gas meter be within three feet of any heating boiler or sources of ignition and, except for buildings in occupancy group J-3, there shall be a physical barrier required if the room is also used for storage purposes or the like.

P115.7 Gas Piping Materials And Fittings.-

(a) Piping materials and piping joints.-All materials used in gas distribution piping systems operating at 1/2 psig or less shall be in accordance with department of buildings' requirements and ANSI Z223.1-1974, National Fuel Code, except for the following modifications:

(1) Screwed fittings shall not be used for pipe size above 4 inches in diameter (see section P115.8(e) for distribution piping pressures over 1/2 psig).

(2) Delete paragraph 1.2.6.1(c) of this standard and substitute: "Plastic pipe, tubing and fittings shall not be used for gas distribution or meter piping."

(b) All materials used in gas distribution piping systems having a gas pressure above 1/2 psig shall conform to ANSI B31.2-1968, Fuel Gas Piping, and department of buildings requirements.

(c) All materials used in gas service and meter piping systems shall be in accordance with the requirements as specified by the utility corporation providing the service; and of the department of buildings.

(d) The permissible stress for gas piping shall be limited to not more than 20% of the yield strength of the piping, including all primary and secondary loads.

(e) Plastic pipe shall be limited to polyolefins and shall conform to ASTM D2513-*1976, Thermoplastic Gas Pressure Pipe, Tubing and Fittings.

(f) The definition of plastic (noun) is a material which contains as an essential ingredient an organic substance of large molecular weight, is solid in its finished state and, at some stage of its manufacture or processing can be shaped by flow. Thermoplastic is defined as a plastic which is capable of being repeatedly softened by increase of temperature and hardened by decrease of temperature.

**As enacted but "1974" probably intended.*

Reference Standard 16

P115.8 Installation Of Gas Piping.-

(a) The installation of gas service piping shall be made in accordance with the requirements of the utility corporation providing the service as regulated by Part 255, of Title 16, of the Official Compilation of Codes, Rules and Regulations of the State of New York. Further, such installation shall meet the requirements of the department of buildings.

(b) Gas service piping outside a structure shall be installed not less than 24 inches below grade, except that a lesser distance of not less than 18 inches may be permitted, provided the piping is adequately protected in accordance with the requirements of this code and the utility corporation supplying service, and the piping is not located below a driveway. Any piping that is exposed to outdoor temperatures or installed underground with a cover of less than 2 feet shall be protected against frost, except that frost protection may be omitted in areas where the utility company certifies that dry gas is being distributed.

(c) The installation of gas meter piping shall be made in accordance with the requirements of this code and the local utility company. Piping containing gas with a pressure exceeding 1/2 psig and the gas service pressure regulator which may be subjected to accidental vehicular impact shall be suitably protected.

(d) Welders installing gas piping within buildings at any pressure shall be qualified for all pipe sizes, wall thicknesses and all positions in accordance with either API 1104-1977, 14th edition, or ASME Section IX Boiler and Pressure Vessel Code, 1980 and requalified on an annual basis. The qualification testing shall be performed by an agency listed with the department of buildings, and the inspector shall have a minimum radiography qualification of Level II in accordance with the American Society of Non-Destructive Testing Recommended Practice Document No. SNT-TC-1A, Supplement A. Copies of the certified welder qualification reports shall be maintained by the responsible welding contractor and shall be made available to the department of buildings upon request.

(e) All welded gas distribution and meter piping main and branch supplies to customer equipment operating in excess of 3 psig inside buildings shall be butt welded; and shall be subject to controlled inspection, as set forth in section C26-106.3.

(f) Radiography shall be performed on all butt welds in gas meter and gas distribution piping operating at pressures exceeding 3 psig, within buildings, in accordance with API 1104-1977 or ASME Section IX Boiler and Pressure Vessel Code 1980.

(g) All requirements for installation of gas distribution piping with pressures of 1/2 psig or less shall be in accordance with P115.7 and Z223.1-1974 Part I, National Fuel Gas Code, subject to the following modifications. Section numbers referred to are those in

that standard.

1.2.10.14 Add the following to this section:

(h) Branches shall be taken off the riser with not less than a two elbow swing:

1.2.10.15 Electrical bonding and grounding.-Delete this section and replace it with the following:

The gas piping system shall not be used for an electrical ground.

(i) Where piping supplies equipment for incidental outside use, the minimum ground cover shall be 18 inches. Where compliance with this requirement would be unusually difficult, a lesser distance may be permitted provided the piping is adequately protected in accordance with the requirements of this code and the department of buildings. In all cases where piping is installed in concrete, screwed fittings shall not be used, and the piping shall be coated to prevent corrosion, and in all cases where corrosive conditions exist, the pipe shall be adequately protected against corrosion.

(j) Concealed piping as defined in sections 1.2.8 and 2.4.8 of Z223.1-1974 shall not include piping installed in pipe shafts. Where piping is installed in a shaft, the shaft shall have a fire protective rating as prescribed in the requirements for fire protection construction of the building code.

(k) All requirements for installation of gas distribution piping with pressure above 1/2 psig shall be in accordance with Z223.1 Part II National Fuel Gas Code. Gas distribution piping operating at a pressure of over 1/2 psig to 3 psig and of a size 4 inches or larger shall be welded. All gas distribution piping operating at a pressure above 3 psig shall be welded. All welding of gas distribution piping shall be subject to controlled inspection as set forth in section C26-103.3.

(l) When the structure is erected on fill or on piles, provisions shall be made to preclude possible damage to the gas distribution piping caused by settlement.

(m) Gas distribution piping operating at pressures above 1/2 psig shall be marked to identify the maximum pressure levels within the piping. All valves shall be suitably tagged to indicate the operating pressure level within the distribution piping. In no case shall there be any inter-connections between distribution piping at different pressure levels. Piping at different pressure levels in the same space shall be color coded.

(n) Gas distribution piping operating at pressure levels above 10 psig shall be located within spaces having a 3 hour fire rating for walls and partitions and a 2 hour fire rating for floors and ceiling. Areas containing gas distribution piping operating at pressure levels above 15 psig shall require and/or comply with all of the following:

(1) A 3 hour fire rating.

(2) A suitable fire protection system as approved by the commissioner.

(3) A combustible gas detection alarm system.

(4) Controlled inspection of the piping system as set forth in C26-106.3.

Reference Standard 16

(5) Gas pipe shafts shall not be located in stairways, shall be sealed to prevent any gas leakage from the shaft, shall conform to high hazard requirements, and shall be vented to the open air at the top.

(6) Compressors and/or turbines using gas at 15 psig or over shall be located in rooms provided with explosion venting in accordance with NFPA Std. No. 68-1978 and compressor, turbine, meter and boiler rooms shall be provided with adequate mechanical and fixed ventilation.

(7) The gas meter room shall be gas tight, shall be entered from the outside only, and shall be vented to the outer air only.

(8) Electrical equipment in meter, compressor and turbine rooms shall conform to the Electrical Code of the City of New York for Class 1 Division 1 occupancies.

(9) Any gas tank used shall conform to section C19-91.0(c) and (d), and compressing of gas shall be under the supervision of a person holding a certificate of fitness in accordance with section C19-91.0(b).

(10) Piping at different pressure levels in the same space shall be color coded.

(11) The concurrence of the fire commissioner shall be obtained for all such high pressure gas installations, operating at 15 psig or over.

(o) Plastic service piping, either insert or direct burial, conforming with section P115.7(c) may be installed subject to the following restrictions:

(1) Wherever plastic insert piping is used, the existing service piping shall act as a mechanical protection between the plastic piping and the surrounding environment. The remaining gas service pipe shall be prepared to the extent necessary to remove any sharp edges, projections, or abrasive material which could damage the plastic during and after insertion. Plastic pipe or tubing shall be inserted into the casing pipe in such a manner as to protect the plastic during the installation. The leading end of the plastic shall be closed before insertion. Care shall be taken to prevent piping from bearing on the end of the casing.

(2) Persons engaged in the installation of the plastic piping shall be formally trained, qualified, and certified by the serving utility company.

*(3) Plastic piping shall not extend more than 3 inches beyond the inner face of the building wall, and shall not be exposed inside the building. Plastic piping may extend into the building a maximum of one foot horizontally and four feet vertically immediately adjacent to the inner face of the building wall when encased in a metallic sleeve and constructed and vented so that uncontrolled gas cannot escape from the metallic sleeve inside the building.

**Local Law 38-1989*

(4) Joints shall be either mechanical or heat fusion joints, only. Each plastic pipe fusion joint must be made in accordance with written procedures that have been proven by destructive burst test to produce joints at least as strong as the pipe being joined.

a. When plastic pipe, tubing, or fittings of different

material specifications are joined together by heat fusion, a thorough investigation shall be made to determine that the materials are compatible for joining purposes. The joining method used must be compatible with the materials being joined. The recommendations of the manufacturer shall be considered when determining the method to be used.

b. Mechanical joints. When compression type mechanical joints are used, the gasket material in the coupling must be compatible with the plastic. An internal tubular rigid stiffener shall be used in conjunction with the coupling. The tubular stiffener shall reinforce the end of the pipe or tubing and shall extend at least to the outside end of the compression fitting when installed. The stiffener shall be free of rough or sharp edges and shall not be a force fit in the plastic. A split tubular stiffener shall not be used.

(5) Changes in direction with plastic piping may be made with bends, elbows and tees. Bends shall be free of buckles, cracks, or other evidence of damage. No miter joints are permitted. The pipe may be bent or deflected provided the radius shall not be less than the minimum recommended by the manufacturer.

(6) The minimum allowable wall thickness for plastic pipe shall be 0.090 inches.

(7) Plastic pipe shall be laid, and continuously supported, on undisturbed or well-compacted soil to minimize shear stresses. Backfill material for at least 4 inches over the plastic pipe shall be free from large rocks or sharp objects. The trench shall be backfilled to a height of 12 inches above the pipe in 6-inch lifts which shall be hand compacted. The remaining trench shall be backfilled in 12-inch lifts.

(8) Slack for thermal expansion and contraction or for external loading on direct-buried plastic services shall be provided by snaking the pipe from one side of the trench to the other. Where plastic piping is inserted for a distance of 50 feet or more allowances shall be made at the end connections to prevent pull out caused by thermal or by external loading.

(9) External sleeves shall be used on plastic service lines at main connections to minimize shear stresses.

*(10) Plastic pipe shall not be installed in areas where it may be exposed to temperatures below -20°F or above 140°F. Plastic pipe shall not be installed within 35 feet of an underground steam facility, nor in any vault in which a steam facility is located.

(11) The specific plastic pipe, tubing or fitting to be used shall be thoroughly investigated by the user and material serviceability determined for the conditions anticipated. The selected material shall be adequately resistant to the liquids and the chemical atmosphere which may be encountered. Care shall be exercised at all times to protect plastic material from fire, excessive heat, or harmful chemicals.

(12) The design pressure is not to exceed 100 psig for plastic gas service piping.

(13) The design pressure for plastic gas service piping or the nominal wall thicknesses for a given design

Reference Standard 16

pressure shall be determined by one of the following formulas:

**Local Law 38-1989*

$$P = \frac{2S \times F}{(R-1)} \quad \text{or} \quad P = \frac{2S \times t \times F}{(D-t)}$$

where:

D = Specified outside diameter, inches

P = Design pressure, psi

S = Long term hydrostatic strength, psi
(Determined in accordance with
ASTM D2513)

t = Specified wall thickness, inches

F = Plastic design factor = .32

R = Standard dimension ratio

(14) Inspection and handling provisions. Plastic piping components are susceptible to damage by mishandling. Gouges, cuts, kinks, or other forms of damage may cause failure. Injurious gouges or grooves shall be removed by cutting out the damaged portion as a cylinder and replacing it with a good piece. Care shall be exercised during handling and installation to prevent such damage. The serving utility shall inspect plastic piping and its components to ensure the absence of imperfections in materials, to ensure sound joints are made, and to ensure conformance with applicable state regulations.

P115.9 Gas Piping Sizes.-Pipe sizes for gas distribution shall be in accordance with ANSI Z223.1-1974, subject to the following modifications. Section numbers referred to are those in that standard.

1.2.4.3 Add the following at the end of this section: "Individual outlets to gas ranges shall not be less than 3/4 in."

Section P116.0 Swimming Pools and Display Pools or Fountains

P116.1 Swimming Pools.-

(a) **General requirements.**-Swimming pools regulated by the building code shall be designed, installed, and maintained in accordance with the requirements of this reference standard.

(b) **Prohibited pools.**-The installation of fill and draw pools is prohibited.

(c) **Toilet and shower facilities.**-

(1) Toilets shall be installed in properly ventilated rooms, and shall be conveniently located so as to facilitate their use before the bathers enter the showers. The number of toilets to be provided shall be predicated upon the maximum number of bathers, both adults and children, who can be accommodated at any one time. There shall be at least one toilet provided for every 50 female bathers, at least one toilet and one urinal provided for every 75 male bathers, and at least one wash basin adjacent to the toilets for every 60 persons.

(2) The number of showers to be provided shall be

predicated upon the maximum number of persons, both adults and children, who can be accommodated at any one time. At least one shower shall be provided for every 50 persons; but in no case shall there be less than two showers. Showers shall be supplied with hot and cold water, and shall be designed so that a proper mixture of hot and cold water can be obtained without the danger of scalding the bather. The entrance to the pool area from the dressing room shall be preceded by the shower room.

(d) **Drainage.**-

(1) At least one drainage outlet shall be installed in the deepest portion of the pool and shall be of sufficient size to drain the entire pool in 8 hours. The main drain outlets shall be provided with a vortex-and-suction-reducing device consisting of an outlet strainer or grating having a total open area equal to at least four times the area of the pool drain pipe. Or sufficient grating area shall be provided so that the maximum velocity through the grate does not exceed 1 1/2 fps. The minimum width of grating openings shall be 1/2 in. Multiple outlets shall be provided where the width of the pool is more than 30 ft. and such outlets shall not be spaced more than 30 ft. apart nor more than 15 ft. from the side walls. The pool drain connection shall be installed so as to prevent the reversal of flow from the sewer to the pool.

(2) Pool overflows shall be installed and constructed so that the overflow water is returned to the filter by means of overflow (scum) gutters, roll-out or deck level pool drains, or skimmers, along with the water returned to the filter through the main drain.

a. Overflow (scum) gutters shall extend completely around the pool, except at steps or recessed ladders in the shallow portion. The gutter shall be capable of continuously removing 50 percent or more of the recirculated water and returning it to the filter. All overflow gutters shall connect to the recirculation system through a properly designed surge tank. Where vacuum filters are used and are below the pool water level, the filter tank can be used as the surge tank. Piping from the gutter drains of the pool must be designed to rapidly remove the overflow water, but the maximum flow rate should not exceed 6 fps.

1. The gutters shall be designed so that they can be cleaned easily. The opening into the gutter beneath the coping shall be at least 4 in., and the interior of the gutter shall be at least 3 in. wide and 3 in. deep. Where large gutters are used, they shall be designed to prevent entrapment of the bather's arms or legs. They shall be designed in accordance with the standards of American public health service.

2. Overflow outlets or drains shall be installed at intervals sufficient to provide equal removal of the overflow from the entire surface of the pool. The outlet fittings shall connect to the return piping through 2 in.

Reference Standard 16

pipe connections, and the clear opening in the drain grating shall be at least equal to 1 1/2 times the cross-sectional area of the outlet pipe.

3. Continuous flow gutters with single or multiple outlets may be used provided they are self-cleansing and capable of maintaining an effective skimming action. Their use is normally limited to recirculating systems employing vacuum filters.

b. Roll-out deck level type pool overflows shall be designed to conform to the provisions for overflow rates as stated in a. above. The curb and handhold shall be designed so as to prevent splash-back of overflowed water. The design shall be subject to approval by the Commissioner.

c. Skimmers may be used in pools provided handholds are installed and provided at least one skimming device is installed for every 500 sq. ft. of pool surface area or fraction thereof. Skimmers shall be located so as to minimize interference with each other and insure proper skimming of the entire surface. Skimmers shall be built into the pool wall, and shall develop sufficient velocity on the pool water surface to induce surface skimming. The skimmers shall be provided with flow-rate adjustment valves to balance the system. Also, the skimmer shall meet the following requirements and the NSF standards.

1. The piping and other pertinent components shall be designed for a total capacity of at least 80 percent of the required filter flow, with a minimum skimmer flow-through rate of either 30 gpm or 3.75 gpm per lin. in. of weir.

2. The skimmer weir shall be capable of automatically adjusting to water level variations through a range of at least 4 in. The weir shall be of a buoyancy and design that will allow it to develop an effective velocity.

3. An easily removable and cleanable basket or screen through which all overflow water must pass shall be provided to trap large solids.

4. Provisions shall be made to prevent airlock in the suction line or to protect the pump in the event the pool water level drops below weir level. If an equalizer line is used, it shall be sized to meet the capacity requirements of the filter and pump, and shall be at least 2 in. in diameter and capable of providing at least 30 gpm of water for pump suction without air entrainment. The equalizer line shall be located at least 1 ft. below the lowest overflow level of the skimmer, and shall be provided with a valve that remains tightly closed under normal operating conditions but will automatically open when the skimmer becomes starved. Where vacuum filters are used, a separate suction pump shall be provided.

(e) Inlets.-A pool shall have inlets of such size and spacing so as to facilitate uniform circulation of water throughout the pool. The inlets shall be submerged sufficiently to prevent loss of chlorination or other disinfectant. There shall be no direct connection between the pool piping system and the domestic water supply system. An inlet shall be located not more than 5 ft. from the corner of the pool, and the inlet spacing shall not exceed 20 ft., unless otherwise permitted by the Commissioner.

Inlets shall be of the adjustable type and shall be located at least 12 in. below the pool water level.

(f) Recirculation and Filtration.-A pool shall have a water recirculation system consisting primarily of piping, pumps, filters, disinfecting equipment, and other standard accessory equipment that shall be adequate to clarify and disinfect the contents of the pool within 8 hrs. A flow meter shall be provided to indicate and record the rate of pumpage. The surface of the filter medium of all filters shall be of such size that the rate of filtration does not exceed 3 gpm per sq. ft. of surface area, except that when diatomaceous earth filters are used, the rate of filtration shall not exceed 2 gpm per sq. ft. of surface area. The recirculation system shall be kept in operation 24 hr. a day while the pool is in operation. Filters shall bear the seal of approval of NSF.

(g) Hair and lint catchers.-A strainer shall be provided that is easily accessible for cleaning. The strainer shall be of corrosive resistant materials with 1/8 in. openings or less, and shall provide a free flow area of at least four times the area of the pump suction lines.

(h) Disinfection.-

(1) The pool shall have an effective means of disinfection introduced by mechanical means. The equipment shall be capable of providing at least 8 ppm chlorine at the turnover rate of the pool.

(2) Chlorine, calcium hypochlorite, or similar compounds not containing ammonia, shall be used to disinfect a pool. The use of ammonia or ammonia compounds is prohibited.

***(3)** Liquefied chlorine shall be used only when permitted by the Commissioner. It shall be stored only in a separate room or enclosure constructed of non-combustible materials having a fire-resistance rating of at least one hour and its use shall comply with the requirements of the fire department.

**Local Law 85-1973*

***(4)** When chlorine gas is used as a disinfectant, at least two gas masks in good operating condition and of a type approved by the United States bureau of mines for high concentrations of chlorine gas, shall be provided. The gas masks shall be kept at a readily accessible point near the chlorinators feeding chlorine gas but outside the chlorinator room. The room housing chlorinator shall be located at grade level with direct egress to the outer air and provided with an automatic sprinkler system constructed in accordance with the provisions of article seventeen of the building code. The domestic water supply may be used to supply the sprinklers when it complies with section C26-1703.9(e). A drain shall be provided in the floor of the room.

**Local Law 85-1973*

(i) Heating.-A swimming pool shall not be heated by the direct injection of steam into the pool or by the direct installation of electrical heating elements in the pool.

(j) Make-up water.-Make-up water shall be supplied to the pool through an air gap by one of the following means:

(1) Through a fill spout above the pool rim, preferably installed under the diving board.

Reference Standard 16

- (2) Through a make-up tank.
- (3) Through the filter tank of vacuum diatomaceous earth filters.

(k) Water standards and quality.-

- (1) A pool shall use water from the public water supply system or such other source as may be approved by the department of health.
- (2) Water in a pool shall be treated and maintained so that not more than 200 bacteria per milliliter appear in the test sample, nor shall the test sample show a positive (confirmed) test for bacteria of the coliform group in any of five 10 milliliter portions.
- (3) The amount of free chlorine in the water, as determined by an orthotolidine test at 60 degrees F or less, shall be at least 0.4 ppm. The dechlorinated water shall have a pH value in the range of 7.2 to 8.2.
- (4) The surface of water in a pool shall be reasonably free from scum and floating matter. The water in a pool shall be sufficiently clear to permit a 6 in. black disc on a white field, placed on the bottom of the pool at the deepest point and 10 ft. from the side, to be clearly visible from the runway around the deep area of the pool. The bottom and sides of the pool shall be maintained free from sediment, dirt and slime.
- (5) Tests of pool water shall be performed in accordance with "standard methods for examination of water, sewage, and industrial wastes," published jointly by the American Public Health Association, American Water Works Association, and Federation of Sewage and Industrial Waste Associations, eleventh ed. The tests, as required by the department of health to maintain an operating permit for the pool, shall determine the presence of residual chlorine, the pH value of the water, and the clearness of the water. The tests shall be made by the pool operator as frequently as necessary throughout each day to maintain the standards required by this section.

(l) Pipe identification.-Pipes used for different purposes shall be painted different colors to facilitate identification. The colors shall be as follows:

- potable water pipe-green
- recirculation water pipe-light blue
- backwash and wash water pipe-gray
- chlorine pipe-yellow
- well water pipe-red

P116.2 Display Pools and Fountains.-

- (a) Water connections.-**No direct or submerged water connections shall be made to a display pool or fountain.
- (b) Drainage.-**Each display pool or fountain shall be provided with a drain connection. The circulating or fountain pumps may be used to drain the pool to either the storm, sanitary, or combined sewer.
- (c) Recirculation required.-**Any display pool or fountain that will waste more than 2,000 gal. per day based on continuous 24 hr. operation shall be provided with a recirculation system. A statement from an architect or engineer attesting to the amount of water wasted shall be filed with the plans for any display pool or fountain.

(d) Treatment.-The water shall be treated with chemicals, either mechanically or hand fed, to prevent odors, mosquito breeding, and other health hazards. Chemicals used shall be nontoxic to animals or human beings. In lieu of chemical treatment, the entire pool may be drained at intervals provided the water wasted does not exceed the amount specified in (c) above.

Note: Excerpts from Local Law 7-1974

Section 1. The council finds that serious flooding and ponding problems exist in areas of the city of New York which are presently without adequate sewers for the disposal of storm water. The council further finds that these flooding and ponding problems endanger human life and cause substantial property damage. As the primary means of reducing these problems, the city of New York currently is engaged in an accelerated sewer construction program, approved by the council, of unprecedented scope. The city is also engaged in an active program of maintaining existing watercourses and other storm water disposal systems pursuant to orders of the city's Board of Health. It is the expectation of the council that in the next twenty years the city sewer construction program will provide a large network of storm sewers for the areas of the city which presently lack them. In addition, however, the council recognizes that present construction of new buildings and developments without adequate storm water drainage in these unsewered areas is worsening existing flooding and ponding problems, and that the stringent storm drainage requirements for property owners set forth in this local law, which terminates December thirty-first, nineteen hundred ninety three, are necessary as a temporary measure until the city has substantially advanced its accelerated sewer construction program.

§10 This local law shall take effect thirty days after it shall have become law. Its requirements insofar as they differ from or are additional to those of the administrative code of the city of New York in effect immediately prior to the effective date of this local law shall apply to the construction of all new buildings for which applications for new buildings permits have been filed on or after such effective date; provided, however, that such new or different requirements shall not apply to the construction of new buildings on specific sites for which schemes for storm water drainage have been approved by the environmental protection administration on or before such effective date if such construction lawfully commences within five years after such approval. A scheme for storm water drainage for the purpose of this section is an undetailed plan which shows the proposed drains, sewers and/or other means of storm water disposal, which the environmental protection administration normally requires property owners to submit to it prior to the submission of a detailed plan for the construction of such facilities. Effective date, May 16, 1974.

Reference Standard 16

INDEX Reference Standard RS-16

All references are to section numbers

A

Air conditioners, used water return, P107.17
Air conditioning, connections, see
Connections, Air Conditioning
Air gap, P107.18(1)
Ammonia, P116.1(h)(2)
Anchors, P106.1
Asbestos-cement pipe, joints, P103.1(a)
Aspirators, P107.13(2), P114.11(a)
Auxiliary water systems, P107.7

B

Backfill, P101.2
materials, P101.2(a)
Backflow, preventers, P107.13, P107.20(a)
protection against, P107.18
Back-siphonage, protection against, P107.18
Backwater valves, P105.9
design, P105.9(b)
Ball cocks, P107.8(b)
Baskets, indirect waste, P111.5(b)
Bathtubs, P104.8, P109.13(a)
Bedpan, hoppers, P114.3
steamers, P114.7(c)
sizing, P114.9(a)
vents, P114.8(c)
washers, P107.24, P114.3, P114.8(c)(1)c
connections, P107.24
drainage, P114.6(b)
Bidets, P107.13(1)
Boiler feedback system connections, P107.14
Boilers, waste piping, P111.1(b)(8)
Booster pumps, P107.9
Bowls, water closets, P104.2(d)
Branch vent size, P109.1(c)
Brazed joints, P103.1(b)

C

Cast iron joints, P103.1(c), see also Joints, cast iron
Caulking ferrules, materials, P102.4(e)(7)
Cesspools, P113.5
Check valves, P107.4
pump discharge, P107.9(f)
Chemical waste, materials, P102.4(b)(5)
piping materials, P112.2(c)
Chlorine, P116.1(h)(2)
Cleanouts, plug materials, P102.4(e)(10)

clearances, P105.3(g)
equivalent, P105.3(i)
location, P105.3(a)
size, P105.3(f)

Clear water waste discharging, P111.1(b)(6)

Clinic sinks, P114.3(a), P114.3(b)

drainage, P114.6(b)

Clothes washers, P104.12

Color marking, water supply identification, P107.10(d)

Common vents, P109.7

Concrete pipe joints, P103.1(i)

Condenser, exhaust, P114.7(e)

Connections, P103.0, see also Joints

air-conditioning, P107.16

metered premise, P107.16(3)

water, P107.16(1)

water conserving, P107.16(4)

water regulating, P107.16(5)

bedpan washers, P107.24

boiler feed systems, P107.14

cooling systems, P107.14

gas piping, P115.2

heating systems, P107.14

laboratory outlets, P107.24

preheating apparatus, P107.21

prohibited, P107.13

sewer, P108.2

abandonment, P108.3

solution tanks, P107.23

street sewer, P108.2

sub-stack, P109.3(f)

sump pump, P107.22

well pump, P107.22

Continuous-flow gutters, P116.1(d)(1)a

Controls, tank, P107.6(e)

valve, P107.6(h)

Copper tube, joints, P103.1(j)

Copper materials, P102.4(e)(5)

Couplings, joints, P103.1(k)

Crown vents, P109.8(c)

Curb valves, P107.2(b)(9)

Cut-off, emergency, P107.26(e)

D

Dead ends, P108.8(d)

Definitions (where required), P110.2(a)

Discharge, dishwasher, P111.6

laundry, P111.6

Dishwashing machines, P104.11

commercial, P104.11(d)

discharge, P111.6

domestic, P104.11(b)

Disinfection, P107.27

swimming pools, P116.1(h)

Display pools, P116.0, P116.2

Reference Standard 16

recirculation, P116.2(c)

Disposal field, see Subsurface disposal field

Distribution box, P113.0

Downspout materials, P102.4(e)(2)

Drainage, area, P108.7

bedpan washers, P114.6(b)

below sewer level, P108.6

clinic sinks, P114.6(b)

fixtures, value, P108.9(a)

continuous or semicontinuous flow, P108.9(b)

ice storage chests, P114.6(a)

one-, two-, or three-family buildings, P110.2(c)(3)

outlets, waste piping, P111.1(b)(5)

piping, change of directions, P108.8(b)

pitch of horizontal, P108.8(a)

prohibited fittings, P108.8(c)

provision for future fixtures, P108.8(e)

sizing, P108.10

underground, minimum size, P108.10(e)

sanitary, see also Sanitary drainage

sterilizer vent stack, P114.8(d)(2)

storm, P110.0, see also Storm drainage

sub-soil, P108.7

swimming pools, P116.1(d)

Drains

areaway, P110.2(e)

carrying clear water, P110.2(f)

floor, P104.17

sterilizer, P114.7(b)

vents, P109.8(d)

funnel, P104.19

material, P102.4(b)

roof, see Roof Drains

and sewers combined, size, P110.4(e)

sub-soil, materials, P102.4(e)(3)

swimming pools, P111.1(b)(7)

waste piping, P111.1(b)(3)

drainage system design, P110.2(g)

Draw pools, P116.1(b)

Drinking fountains, P104.16

prohibited, P104.16(c)

Drip pipes, P108.11

Drips, P110.2(c)

waste piping, P111.1(b)(5)

Dry wells, P110.13(d)

one- and two-family dwellings, P110.13(d)(2)

required, P110.13(d)

size, P110.13(d)(1)

E

Ejector, P108.6

Environmental Protection Administration, P110.2

Equivalent cleanouts, P105.3(i)

Excavation, P101.2

Exhaust condenser, P114.7(e)

Expansion joints, P103.1(l), P110.11

F

Field disposal, see Subsurface disposal field

Filters, swimming pool, P111.1(b)(7) P116.1(f)

Filtration, swimming pools, P116.1(f)

Fire lines, meters, P107.3(a)(2)

Fittings, gas piping, P115.6

materials, P102.4(d)

Fixtures, P104.0

accessibility, P104.1(d)

bathrooms, P104.8

clothes washers, P104.12

dishwashing machines, P104.11

drainage, P108.9

drinking fountains, P104.16

floor drains, P104.17

floor outlet, P104.2(c)

funnel drains, P104.19

garbage can washers, P104.14

hospital, P114.2

installing, P104.2

laundry trays, P104.13

lavatories, P104.7

minimum number, P104.1(a)

overflows, P104.3

physically handicapped, P104.1(c)

pools, P116.1

separate, P104.1(b)

showers, P104.9

sinks, P104.10

strainers, P104.15

traps, domestic dishwashers, P105.1(a)(4)

prohibited, P105.1(c)

sizes, P105.1(b)

separate, P105.1(a)

separate, exceptions, P105.1(a)

urinals, P104.5

vents P109.8

wall-hung vents, P109.8

water closets, see Water closets

water supply protection, P104.2(e)

Flanges, floor materials, P102.4(e)(9)

Flashings, roof drain, P110.10

waterproof, P109.4(c)

Flat decks, roof drain strainers, P110.9

Floor drains, P104.17, P107.13(5)

sterilizer, P114.7(b)

Flushing devices, P104.6

flush tanks, P104.6(d)

flushometer valves, P104.6(c)

urinals, P104.6

water closets, P104.6

Flush pipe materials, P102.4(e)(11)

Flush tanks, P104.6(d)

Reference Standard 16

ball cocks, P104.6(d)(2)
Flushometer valves, P104.6(c)
Fountains, P116.0, P116.2
drinking, P104.16
recirculation, P116.2(c)
Fresh air inlets, P108.5
Funnel drains, P104.19

G

Gap, air, P107.18(1)
Garbage can washers, P104.14
Gas meter, location, P115.6
outside installation, P115.6
Gas piping, P115.0
distribution pressures, P115.3
fittings, P115.7
installation, P115.8
materials, P115.7
meter location, P115.6
service connections, P115.2
sizes, P115.9
Gas service connections, P115.2
outside cut-off, P115.5
regulator and regulator vent outlets, P115.4
Glass pipe joints, P103.1(n)
Grading, vent, P109.5(a)
Gravity tank, P107.7(a)(1)
Grease interceptors, P105.4(d)
Gutters, continuous flow, P116.1(d)(1)a
pool overflow, P116.1(d)(1)
roof, size, P110.4(d)
swimming pool, P116.1(d)(1)a

H

Hair catchers, swimming pools, P116.1(g)
Hangers, materials, P106.0
Headers, vent, P109.3(e)
Heating equipment, water, valves, P107.6(f)
Heating systems, connections, P107.14
Hospital plumbing, P114.0
clinic sink drainage, P114.6(b)
fixtures, number of, P114.5
hot water supply, protection, P114.10(c)
mental hospital, P114.4
oxygen and nitrous oxide systems, P114.12
special fixtures, P114.2
requirements, P114.3
sterilizers, P114.3(d)
vacuum systems, P114.11
water supply, P114.10
protection, P114.10(a)
services, P114.10(a)
House pumps, P107.9
Hubs, double, P108.8(c)(2)

Hydropneumatic tanks, P107.8(f)

I

Ice storage chests, drainage, P114.6(a)
Indirect wastes, common, P111.2
piping, P111.0
sterilizer, P114.7(a)
Inlets, fresh air, P108.5
submerged, P107.20(a)
swimming pool, P116.1(e)
Installation, gas piping, P115.8
Institutional plumbing, P114.0
fixtures, number of, P114.5
Insulation materials, P102.4(e)(13)
Interceptors, P105.4
accessibility, P105.7
bottling establishments, P105.5(c)
grease, P105.4(d)
capacity, P105.4(d)(4)
laundry, P105.5(b)
maintenance, P105.8
oil, venting, P105.6(a)
sand, P105.5(a)
slaughter houses, P105.5(d)
venting, P105.6(b)

J

Joints, P103.0
asbestos-cement pipe, P103.1(a)
brazed, P103.1(b)
cast iron, P103.1(c)(d)
caulked, P103.1(d)(1), P103.1(e)
mechanical, P103.1(d)(2), P103.1(f)
clay sewer pipe, P103.1(g)
concrete pipe, P103.1(i)
concrete sewer pipe, P103.1(h)
copper tube (K or L), P103.1(j)
couplings, P103.1(k)
different piping material, P103.2
drainage pipe and fixtures, P103.3
expansion, P103.1(l), P110.11
roof drain, P110.11
glass pipe, P103.1(n)
hot poured, P103.1(m)
preformed, P103.1(o)
soldered, P103.1(q)
threaded, P103.1(r)
threadless copper, P103.1(s)
tightness, P103.4
unions, P103.1(t)
waterproofing openings, P103.5
wiped, P103.1(u)

L

Reference Standard 16

Laboratory outlet connections, P107.25

Laundry trays, P104.3, P109.13(a)

Lavatories, P104.7

Leaders, P110.7

exterior, materials, P102.4(e)(2)

size, P110.4

storm drainage, P110.7

storm water, P110.8

vertical size, P110.4(c)

Lead materials, P102.4(e)(6)

Lint catchers, swimming pool, P116.1(g)

M

Materials, anchors, P106.1

backfill, P101.2(a)

building sewers, P102.4(a)(3)

caulking ferrules, P102.4(e)(7)

chemical wastes, P102.4(b)(5)

 piping, P112.2(c)

cleanout plugs, P102.4(e)(10)

 slip, P103.1(p)

drainage systems, P102.4(b)

downspouts, P102.4(e)(2)

exterior leaders, P102.4(e)(2)

fittings, P102.4(d)

floor flanges, P102.4(e)(9)

flush pipes, P102.4(e)(11)

gas piping, P115.6

hangers, P106.0

insulation, P102.4(e)(13)

lead bends, P102.4(e)(4)

plastic, P102.2(b)

 requirements, P102.2(b)

roof drains, P102.4(e)(1)

sheet copper, P102.4(e)(5)

sheet lead, P102.4(e)(6)

soldering bushings, P102.4(e)(8)

standards, P102.2

subsoil drains, P102.4(e)(3)

supports, P106.1

toxic, P107.11

traps, P102.4(e)(4)

 tubular brass, P102.4(e)(12)

underground piping, P102.4(b)(2)

underground yard drainage, P102.4(b)(4)

venting, P102.4(c)

 above ground, P102.4(c)(1)

 chemical waste, P102.4(c)(3)

 systems, P102.4(c)

 underground, P102.4(c)(2)

 water distribution system pipe, P102.4(a)(2)

 water service pipe, P102.4(a)(1)

 water supply systems, P102.4(a)

Mental hospital plumbing, P114.4

Metal tags, water supply identification, P107.10(d)

Meters, P107.3

air conditioning, P107.3(a)(3)

buildings under construction, P107.3(a)(1)

fire lines, P107.3(a)(2)

gas, see Gas meter

location, P107.3(b)

miscellaneous fixtures, P107.3(a)(4)

refrigeration, P107.3(a)(3)

setting, P107.3(c)

size and type, P107.3(d)

N

Neutralizers, acid dilution pump, P112.2(h)

Neutralizing pits, P105.4

accessibility, P105.7

maintenance, P105.8

venting, P105.6

Neutralizing wastes, P105.5(e)

O

Offsets, P108.10(f), P109.3(d)

prohibited, P108.10(f)(5)

stack vents, P109.3(d)

Oil, interceptors, P105.6(a)

separators, P105.4(e)

wastes, P112.3

Outlets, drainage, P111.1(b)(5)

laboratory connections, P107.25

regulator, P115.3

swimming pool, P116.1(c)(3)

Overflows, P104.3

connection, P104.3(b)

design, P104.3(a)

swimming pools, P116.1(d)(1)

waste piping, P111.1(b)(3)

P

Permits, sanitary drainage piping, P108.1

storm drainage piping, P110.1

water supply, P107.1

Pipes, asbestos cement, joints, P103.1(a)

concrete, joints, P103.1(i)

drip, P108.11

flush, materials, P102.4(e)(11)

glass, joints, P103.1(n)

protection, P101.1

service, see Service pipe

swimming pool, identification, P116.1(1)

water service, materials, P102.4(a)(1)

Piping, chemicals, materials, P112.2(c)

concealed, P115.7(c)

drainage, sizing, P108.10

Reference Standard 16

gas, see Gas piping
horizontal, support intervals, P106.3(b)
indirect waste, P111.1
sanitary drainage, P108.0
permits, P108.1
sewer, sizing, P108.10(b)
storm drainage, P110.0
permits, P110.1
storm water, P110.8
swimming pool, P116.1(1)
underground, materials, P102.4(b)(2)
used, P107.12
vent, materials, P112.2(c)
vertical, support intervals, P106.3(a)
wastes, see Waste piping

Pits, neutralizing, P105.4, see also Neutralizing pits
seepage, P113.5(a), see also Seepage pits

Plastic materials, P102.2(b)

Plumbing fixtures, see Fixtures

Pools, display, see Display pools
swimming, see Swimming pools

Potable water, protection, P107.10

Preheating apparatus, P107.21

Pressure relief valves, P107.26(b), P107.26(c)

Pressure tanks, waste piping, P111.1(b)(8)

Pressure, sterilizers, P114.7(d)

sizing, P114.9(c)

vent, P114.8(d)

Pumps, booster, P107.9

low pressure cut-off, P107.9(e)

directly off street main, P107.9(a)

house, P107.9

R

Radioactive wastes, P112.4

Ratproofing, P101.4

Receiving tanks, P108.6(c)

Receptors, P111.5

prohibited fixtures, P111.5(c)

standpipe, P111.5(a)(3)

waste, P111.5(a)(1)

Refrigeration, meters, P107.3(a)(3)

Refrigerators, waste piping, P111.1(b)(8)

Relief pipes, waste piping, P111.1(b)(3)

Relief valves, P107.6(f)

waste piping, P111.1(b)(8)

Relief vents, P109.9

size, P109.1(b)

Riser valves, P107.6(b)

Roof drain, flashing, P110.10

materials, P102.4(e)(1)

strainers, P110.9

flat decks, P110.9

general use, P110.9(a)

Roof gutters, P110.4(d)

S

Saddles, P108.8(c)

Sand interceptors, P105.5(a)

Sanitary drainage, combining with storm, P110.8(c)
piping, P108.1

permits, P108.1(a)

Sanitary and storm sewers, P110.12

Seats, water closets, P104.4(d)

Seepage pits, P113.5(a)

capacity, P113.10(a)

construction, P113.10(b)

distribution box, P113.8

Seepage trenches, P113.5(a)

Separators, P105.4

accessibility, P105.7

maintenance, P105.8

oil, venting, P105.6(a)

oil and flammable liquids, P105.4(e)

connection to sewer, P105.4(e)(4)

design, P105.4(e)(2)

venting, P105.4(e)(3)

oil storage tank, P105.4(e)(5)

slaughter houses, P105.5(d)

Septic tanks, P113.5(a), P113.7

capacity, P113.7

construction, P113.7

design, P113.7(d)

maintenance, P113.12

Service pipe

clearance, P107.2(b)(10)

curb valves, P107.2(b)(9)

goosenecks on, P107.2(b)(8)

house control valves, P107.2(b)(12)

installation, P107.2(b)(7)

protection, P107.2(b)(6)

size, P107.2(b)(2)

test, P107.2(b)(11)

Sewage disposal, cesspool, P113.5

housing development, P113.4

individual, P113.3

seepage pits, P113.5(a)

seepage trenches, P113.5(a)

septic tank, P113.5(a)

Sewage ejector, pneumatic, P108.6(e)

Sewage system, building materials, P102.4(a)(3)

individual, P113.1

Sewer connections, P108.2

Sewer, disposal of storm water, P110.2(b)

Sewer, repairs, P110.2(i)

Sewers and drains combined size, P110.4(e)

Showers, P104.9

swimming pools, P116.1(o)

Sinks, P104.10, P109.13(a)

clinic, P114.3(a), P114.3(b)

Reference Standard 16

- drainage, P114.6(b)
 - Skimmers**, P116.1(d)(1)
 - swimming pool, P116.1(c)
 - Sleeves**, P101.3
 - Slip joints**, P103.1(p)
 - Soil percolation, tests**, P113.9
 - Soil stacks, minimum size**, P108.10(c)
 - Solution tanks, connections**, P107.23
 - Stack vents**, P109.3, P109.6
 - minimum size, P109.3(a)
 - offsets, P109.3(d)
 - required, P109.3(b)
 - Standpipe receptors**, P111.5(a)(3)
 - Sterilizers**, P107.13(4)
 - boiler type, sizing, P114.9(b)
 - floor drain, P114.7(b)
 - hospital, P114.3(d)
 - indirect wastes, P114.7(a)
 - pressure, P114.7(d)
 - sizing, P114.9(c)
 - vent, P114.8(d)
 - vent stack, drainage, P114.8(d)(2)
 - vent, stack sizing, P114.9
 - waste, P114.7(f)
 - waste piping, P111.1(b)(4)
 - Stop-and-waste valves**, P107.6
 - Storm drainage**, P110.0
 - areaways, P110.2(a), P110.2(b)
 - capacity, for street, P110.2(h)
 - combining with sanitary, P110.8(c)
 - continuous flow valves, P110.5
 - contractual obligations, P110.2(1)
 - control flow, P110.6
 - leaders, P110.7
 - on-site disposal, P110.13
 - piping, P110.0
 - sanitary sewer, P110.3
 - size, P110.4
 - time, of construction, P110.2(k)
 - traps, P110.7
 - where required, P110.2
 - Storm sewers, continuous flow valves**, P110.5
 - sanitary sewers, P110.12
 - size, P110.4(b)
 - Storm water, leaders**, P110.8
 - piping, P110.8
 - Strainers, indirect waste**, P111.5(b)
 - roof drain, P110.9
 - Subsoil drainage**, P108.7
 - Subsurface disposal field**, P113.11
 - construction, P113.11(b)
 - distance requirements, P113.11(e)
 - maintenance, P113.12
 - size, P113.11(d)
 - Sump pits**, P108.6(a), P108.6(c)
 - Sump pump, connections**, P107.22
 - Sumps**, P111.5
 - acid dilution, P112.2(g)
 - neutralization, P112.2(g)
 - waste, P111.5(a)(1)
 - Supports, intervals**, P106.3
 - base of stacks, P106.3(c)
 - horizontal piping, P106.3(b)
 - vertical piping, P106.3(a)
 - materials, P106.1
 - Swimming pools**, P116.0, P116.1
 - chlorine, P116.1(h)(2)
 - disinfection, P116.1(h)
 - drainage, P116.1(d)
 - draw pools, P116.1(b)
 - filtration, P111.1(b)(7), P116.1(f)
 - fixtures, required, P104.9
 - free chlorine, P116.1(k)(3)
 - gutters, P116.1(d)(1)a
 - hair and lint catchers, P116.1(g)
 - heating, P116.1(i)
 - inlets, P116.1(e)
 - main draw outlets, P116.1(c)(3)
 - make-up water, P116.1(j)
 - overflow, P116.1(d)(1)
 - pipe identification, P116.1(1)
 - recirculation, P116.1(f)
 - showers, P116.1(c)
 - skimmers, P116.1(d)(1)
 - toilets, P116.1(c)
 - waste piping, P111.1(b)(7)
 - water standards, P116.1(k)
- T**
- Tank controls**, P107.6(e)
 - Tanks, ball cocks**, P107.8(b)
 - cleaning, P107.8(g)
 - flush, P104.6(d)
 - gravity, P107.7(a)(1)
 - hot water storage, P107.26(g)
 - location, P107.26(i)
 - hydropneumatic, P107.8(f)
 - oil storage, P105.4(e)(5)
 - overflows, P107.8(a)
 - painting, P107.8(g)
 - pressure, waste piping, P111.1(b)(8)
 - prohibited location, P107.8(d)
 - receiving, P108.6(c)
 - septic, see Septic tanks
 - suction, P107.8(a), P107.9(b)
 - fill line, P107.9(d)
 - size, P107.9(c)
 - Temperature relief valves**, P107.26(b), P107.26(d)
 - Toilets, swimming pools**, P116.1(c)
 - Toilets, workmen**, P101.5
 - Toxic materials**, P107.11

Reference Standard 16

Traps, P105.0

bedpan vent stack, P114.8(c)(2)
building, P105.2, P108.4
domestic dish washers, P105.1(a)(4)
materials, P102.4(e)(4)
prohibited, P105.1(c)
seals, protection, P109.2
separate, P105.1(a)
separate for each fixture, P105.1
storm drain, P110.7
 equivalent, P110.7(c)
water supply, P107.2

Trenches, see page, P113.5(a)

Trenching, P101.2

methods, P101.2(b)

U

Urinals, P104.5

flushing devices, P104.6
prohibited, P104.5(a)
wall-hung trough, P104.5(b)

V

Vacuum breakers, P107.13, P107.18(2), P107.20, P107.23, P107.24

Vacuum filters, swimming pools, P116(d)(1)a

Vacuum systems, P114.11

Valves, backwater, P105.9, P108.7

check, P107.4, P107.9(f)
control, P107.6(h)
curb, P107.2(b),(9)
dwelling units, P107.6(c)
flushometer, P104.6(c)
individual fixture, P107.6(d)
pressure relief, P107.26(b), P107.26(c)
relief, P107.6(f)
waste piping, P111.1(b)(8)
riser, P107.6(b)
stop-and-waste, P107.6
temperature relief, P107.26(b), P107.26(d)
vacuum relief, P107.26(f)
water heating equipment, P107.6(f)

Vapor vents, P114.8

Vent headers, P109.3(e)

Vent piping, materials, P112.2(c)

Vents,

bedpan, P114.8(c)
branch, P109.1(c)
common, P109.7
connections,
 at base and top, P109.3(c)
crown, P109.8(c)
extensions, P109.4(e)(2)
 above roofs, P109.4(a)

 outside building, P109.4(f)
fixture, P109.8
 floor drain, P109.8(d)
 location, P109.8(b)
floor drain, P109.8(d)
grading, P109.5(a)
height above fixtures, P109.5(b)
indirect waste piping, P111.3
interceptors, P105.6(d)
materials, P102.4(c), see also Materials,
 venting
pressure sterilizer, P114.8(d)
relief, P109.9
 offsets, P109.9(a)
 yoke, P109.9(b)
roof penetration, P114.9(e)
size, P109.1
 branch, P109.1(d)
 extension, P109.4(b)
 individual, P109.1(a)
 relief, P109.1(b)
stack, see Stack vents
suds pressure zones, P109.10
terminals, P109.4
 location, P109.4(e)
vapor, P114.8
wet, P109.6

Vent stacks, bedpan, P114.8(c)(2)

minimum size, P109.3(a)
offsets, P109.3(d)
pressure sterilizer, P114.8(d)
required, P109.3(b)
size, P109.1(d)
sterilizer, sizing, P114.9
sub-stack connections, P109.3(f)

Vent systems, combination with waste system, P109.11

W

Washers, bedpan, see Bedpan washers

clothes, P104.12
garbage can, P104.14

Washing machines, P109.10(a)

Waste piping, boilers, P111.1(b)(8)

clear water waste, P111.1(b)(6)
chemical, P112.2(c)
drainage, P111.1(b)(3)
 outlets, P111.1(b)(5)
drips, P111.1(b)(5)
food handling devices, P111.1(b)(1)
indirect, P111.0
laundry washers and extractors, P111.1(b)(2)
overflows, P111.1(b)(3)
pressure tanks, P111.1(b)(8)
refrigerators, P111.1(b)(8)

Reference Standard 16

- relief pipes, P111.1(b)(3)
- relief valves, P111.1(b)(8)
- sizing, P111.4
- sterilizers, P111.1(b)(4)
- swimming pools, P111.1(b)(7)
- Waste receptors**, P111.5(a)(1)
- Wastes, chemical**, P102.4(b)(5), P112.2
 - piping materials, P112.2(c)
 - flammable solvents, P112.3
 - indirect, see also Indirect wastes
 - piping, P111.1
 - strainers, P111.5(b)
 - industrial, P112.1
 - neutralizing, P105.5(e)
 - oil, P112.3
 - radioactive, P112.4
 - sampling manholes, P105.10
 - sterilizer, P114.7, P114.7(f)
- Waste stacks, minimum size**, P108.10(c)
- Waste systems, combinations with vent system**, P109.1(r)
- Water, potable, protection**, P107.10
- Water closets, children's**, P104.4(c)
 - flushing devices, P104.6
 - pipe connections, P104.4(e)
 - prohibited, P104.4(a)
 - public use, P104.4(b)
 - seats, P104.4(d)
 - wall-hung bowls, P104.2(d)
- Water conserving, air conditioners**, P107.16(4), P107.16(9)
- Water hammer**, P107.5(f)
- Water regulating, air conditioners**, P107.16(5)
- Water service pipe**, P102.4(a)(1)
- Water standards, swimming pools**, P116.1(k)
- Water supply**, P107.0
 - color marking, P107.10(c)
 - distribution, P107.5
 - design, P107.5(a)
 - maximum pressures, P107.5(d)
 - minimum branch size, P107.5(c)
 - minimum pressure, P107.5(b)
 - minimum riser size, P107.5(e)
 - water hammer, P107.5(f)
 - hospital plumbing, P114.10
 - hot, P107.26
 - return circulation, P107.26(a)
 - identification, P107.10(d)
 - metal tags, P107.10(d)
 - permits, P107.1
 - piping, P107.12
 - potable, identification, P107.10(b)
 - protection of, P107.10
 - protection, P104.2(e)
 - hospital, P114.10(a)
 - prohibited connections, P107.13
 - service, P107.2(b), see also Service pipe
 - pipe installation, P107.2(b)(7)
 - pipe protection, P107.2(b)(6)
 - separation from building sewer, P107.2(b)(4)
 - size of fire line, P107.2(b)(3)
 - size of taps, P107.2(b)(2)
 - taps to city mains, P107.2
- Water systems, auxiliary**, P107.7
 - dual, P107.10(b)
 - gravity tank, P107.7(a)(1)
 - hydropneumatic booster, P107.7(a)(3)
 - potable, disinfection, P107.27
 - pressure booster pump, P107.7(a)(3)
- Wells, dry**, P110.13(d)
 - required, P110.13(d)
 - size, P110.13(d)(1)
- Wiped joints**, P103.1(u)

Y

- Yoke vents**, P109.9(b)



REFERENCE STANDARD RS 17
FIRE ALARMS, DETECTION AND EXTINGUISHING EQUIPMENT
***LIST OF REFERENCED NATIONAL STANDARDS**

| | | |
|-----------------------|--|----------|
| ANSI/NFiPA No. 13 | Standard for the Installation of Sprinkler System, as Modified | 1989 |
| **ANSI/NFiPA No. 13R | Standard for the Installation of Sprinkler Systems in Residential Occupancies up to and Including Four Stories in Height | 1994 |
| **ANSI/NFiPA No. 13D | Standard for the Installation of Sprinkler Systems in One- and Two-Family Dwellings and Manufactured Homes..... | 1994 |
| ANSI/NFiPA No. 214 | Standard for Water-Cooling Towers | 1988 |
| ***ANSI/NFPA No. 72 | National Fire Alarm Code | 1993 |
| ANSI/ASME B16.4 | Cast-Iron Threaded Fittings, Class 125 and 250 | 1985 |
| UL No. 193 | Alarm Valves for Fire-Protection Service (Revision 9/88)..... | 1988 |
| UL No. 260 | Dry Pipe and Deluge Valves for Fire Protection Service..... | 1988 |
| UL No. 262 | Gate Valves for Fire-Protection Service | 1988 |
| UL No. 312 | Check Valves for Fire-Protection Service (Revision 10/89)..... | 1988 |
| UL No. 668 | Hose Valves for Fire-Protection Service | ****1988 |
| UL No. 753 | Alarm Accessories for Automatic Water-Supply Control Valves for Fire-Protection Service (Revision 8/89)..... | 1989 |
| UL No. 789 | Indicator Posts for Fire-Protection Service (Revision 3/89)..... | 1987 |
| UL No. 1091 | Butterfly Valves for Fire-Protection Service | 1986 |
| UL No. 1468 | Direct-Acting Pressure-Reducing and Pressure-Control Valves for Fire-Protection Service... | 1985 |
| UL No. 1486 | Quick Opening Devices for Dry Pipe Valves for Fire-Protection Service (Revision 7/85).. | 1979 |
| UL No. 1726 | Automatic Drain Valves for Standpipe Systems (Revision 9/88) | 1985 |
| UL No. 1739 | Pilot-Operated Pressure-Control Valves for Fire-Protection Service..... | 1988 |
| ANSI A21.10/AWWA C110 | Ductile-Iron and Grey-Iron Fittings, 3-inch through 48-inch for Water and Other Liquids. | 1987 |
| ANSI A21.11/AWWA C111 | Rubber Gasket Joints for Ductile Iron and Grey-Iron Pressure Pipe and Fittings..... | 1985 |
| ***ANSI/ASTM A234 | Specification for Pipe Fittings of Wrought Carbon Steel and Alloy Steel for Moderate and Elevated Temperatures..... | 1988 |
| ANSI/NFiPA No. 22 | Standard for Water Tanks for Private Fire Protection | 1987 |
| UL No. 217 | Single and Multiple Station Smoke Detectors including Revision of February 19, 1989... | 1989 |
| ANSI/NFiPA No. 74 | Standard for the Installation, Maintenance, and Use of Household Fire Warning Equipment, as Modified | 1989 |
| ANSI/NFiPA No. 20 | Installation of Centrifugal Fire Pumps | 1990 |
| ANSI/NFiPA No. 231 | Standard of Indoor General Storage | 1990 |
| ANSI/NFiPA No. 231C | Standard for Rack Storage of Materials | 1986 |

*310-90 BCR
 **DOB 6-23-99
 ***DOB 1-9-02
 ****As enacted but "1989" probably intended.

Reference Standard 17

***REFERENCE STANDARD RS 17-1
STANDPIPE SYSTEM CONSTRUCTION**

1. Materials for Standpipe Systems-

(a) Pipe-

(1) Pipe for standpipe systems shall be in accordance with table RS 17-1-1, and shall conform to the standards of table RS 16-1, of reference standard RS-16.

(2) Pipe for buried sections of the standpipe system, whether inside or outside of the building, shall be red brass, hard temper type "K" copper tubing, galvanized wrought iron, galvanized steel, cast iron, ductile iron, or approved equivalent material. All such pipe, other than cast iron, shall be adequately wrapped or otherwise

protected against corrosion.

(3) The name of the manufacturer and the pressure to which the pipe was tested shall be permanently and legibly indicated on all pipe used in standpipe systems.

(4) Only new pipe shall be used in standpipe systems.

(b) Fittings-

(1) Fittings used in standpipe systems above ground shall be malleable cast iron, ductile iron or cast steel or approved equivalent conforming to reference standard RS 17-6.

(2) Fittings used in standpipe systems underground shall be cast iron or ductile iron or approved equivalent conforming to reference standards RS 17-7 or RS 17-8.

(3) Pressure ratings shall be cast in or on the fittings. (See table RS 17-1-1 for required ratings.)

*** TABLE RS 17-1-1
REQUIRED RATINGS OF PIPE, FITTINGS AND VALVES IN STANDPIPE SYSTEMS FOR VARIOUS
HEIGHTS OF BUILDINGS ^{c,d}**

| Distance from Upper Tank Check to 1 st Floor or Fire Pump (ft.) | Class of 2 ½ Hose Outlet Valves | Type of Pipe | Check and Fittings (wwp in psi) | Gate Valves (wwp in psi) |
|--|---------------------------------------|--------------------------------|---------------------------------------|-----------------------------|
| 0 to 115 | A ^a | Schedule 10 or 40 carbon steel | 300 | 175 |
| 115 to 270 | A ^a | Schedule 10 or 40 carbon steel | 300 | 250 |
| 270 to 425 | B ^b | Schedule 40 carbon steel | 350 | 350 |
| 425 to 657 | B ^b | Schedule 40 carbon steel | 500 | 500 |
| 657 to 1,112 | B ^b | Schedule 80 carbon steel | 800 | 800 |
| **1,122 and over | B ^b | Schedule 80 carbon steel | 1,000 | 1,000 |

Notes.-

^aFor installation in buildings not exceeding 300 ft. in height or the uppermost 300 ft. in taller buildings. Valve shall close tightly against 300 psi normal hydraulic pressure and shall withstand a hydraulic test pressure of 750 psi.

^bFor installation in the lower portions of buildings exceeding 300 ft. in height. Valve shall close tightly against 400 psi normal hydraulic pressure and shall withstand a hydraulic test pressure at 1,250 psi.

^cSix inches and larger section and riser control valves shall have a valved bypass.

^dSiamese connections shall be rated for the same pressure as is required for interior fittings and valves.

***310-90 BCR**

****As enacted but "1,112" probably intended**

(4) Fittings used in standpipe systems that are of welded construction shall be of a type conforming to reference standard RS 17-9 for welding purposes.

(5) Approved mechanical couplings such as cut groove, rolled groove and mechanical tees may be used in the standpipe system. Fittings used in conjunction with the coupling shall be designed for use with the coupling.

(c) Valves-

(1) Valves and related products used in fire protection shall be approved and comply with reference standard RS 17-6A.

(2) O. S. & Y. indicating valves (with indicator readily visible from the floor) shall be provided to permit any riser or other section to be shut off while remaining risers or sections continue in use. Valves shall be

flanged, mechanically coupled, or wafer type and with bodies of cast iron, ductile iron, cast steel or approved equivalent material having nonferrous metal seat rings. See Table 17-1-1 for required ratings and Figures RS 17-1-1 and RS 17-1-2 for valve locations.

(3) In single riser systems, or where a single riser extends through an upper portion of the building supplying hose outlet valves more than 150 ft. above the curb level, section valves shall be installed in the single riser at the floor where the single riser starts and at increments of not more than 100 ft. above the first valve. The section valve or valves in the upper section of the riser shall be located so as to divide the riser into increments as shown in figure RS 17-1-1, and RS 17-1-2.

Reference Standard 17

Figure RS 17-1-1. Riser and Intermediate Valves (Multi-Riser System).

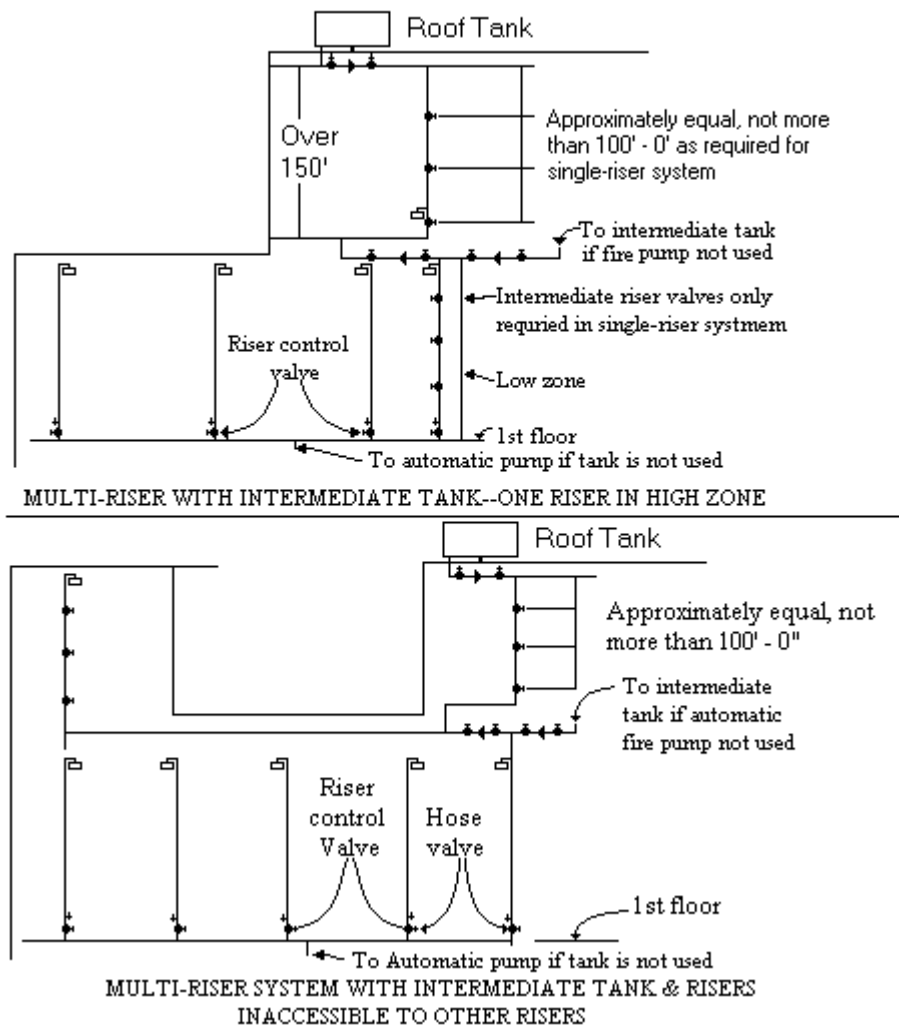

(4) Riser control valves, shall where practical, be located within a required stair enclosure serving the entrance floor. Where the stair enclosure extends to the basement or cellar, the riser control valve may be located within the stair enclosure at or in, the basement or cellar ceiling, providing that a sign indicating the valve location is installed within the stair enclosure at the entrance floor. The hose outlet valve for the entrance floor shall be located on the riser side of the riser control valve. Riser control valves shall not be required on a vertical line supplying one (1) or two (2) hose outlet valves.

(5) Where riser control or section valves are located outside of a required stair enclosure, the valves shall be of such type and so installed so as to be remotely operated by either electric motors or hydraulic means. The remote control shall be from either the entrance floor or from a fire pump room. Operating devices shall be grouped, suitably housed, and kept locked with

a fire department lock and key. The door of the housing shall be embossed to indicate the purpose of the device. Instructions for operating the remote valves by the control device shall be legible, detailed, and complete, and shall be permanently secured to the inner face of the door.

(6) Each valve shall be so designed and installed as to permit its manual operation at the valve location. Pressure ratings and the name of the manufacturer shall be cast raised or depressed on each valve used in the system.

(7) The position of each remotely controlled valve, whether opened or closed, shall be indicated at its remote control point and also at the valve.

(8) Valves shall be readily accessible for inspection, repair, and use.

If the valve is placed so that its operating mechanism is more than 7 ft. above a floor or stair landing, a 12 in. wide wrought iron, steel or equivalent ladder securely fastened shall be provided for access to the valve. In

Reference Standard 17

Figure RS 17-1-2 Riser and Intermediate Valves
(Single and Multi-Riser System).

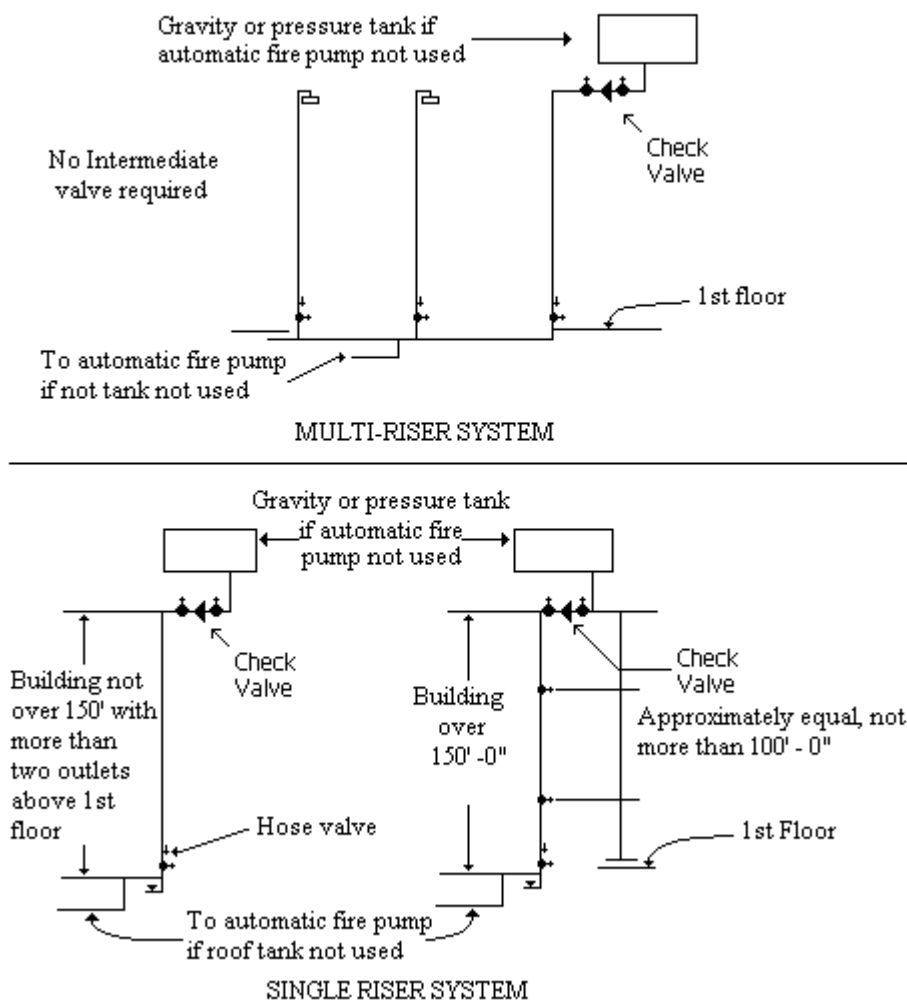

lieu of a ladder, chain operated mechanisms are permissible and shall be padlocked securely in place.

(9) Each control valve shall be conspicuously marked with the number assigned to it on the riser diagram for the standpipe system. Metal numbered tags at least 2 in. in diameter shall be securely attached to the valve. Each valve shall have a metal sign stating "STANDPIPE CONTROL VALVE" securely hung from the valve.

(10) Each control valve not controlled shall be sealed with a lock and chain in its normal position. If the normal position is the closed position, a metal placard stating such fact shall be conspicuously attached to the valve.

(d) Check valves.-(1) Check valves shall be flanged, mechanically coupled, or wafer type and be cast iron, ductile iron, cast steel or approved equivalent materials having nonferrous metal seat rings and bearings. Swing-type valves shall be installed horizontally in pipes from each siamese hose connection, and in piping from each tank, pump, and city water connection. Spring loaded check valves may be installed in the vertical or horizontal position on the discharge side of

fire pumps and tank connections.

(2) Check valves other than those in siamese and fire pump line shall be provided with an O. S. & Y. or indicating shutoff valve (with indicator readily visible from the floor) that is flanged, mechanically coupled or wafer type and connected to the inlet and outlet of such check valves. The valves on the suction and discharge of the fire pump shall be deemed to comply with this requirement when the discharge valve is placed on the discharge side of the check valve. One of the shutoff valves placed on each side of the tank check valve may be of the remote control type, and when used, shall be on the downstream side of such check valve.

(e) Supports.-Piping in standpipe systems shall be adequately supported by clamps, hangers, or other supporting devices.

2. Siamese Connections.-

(a) Design and construction.-

(1) Siamese connections shall have a swing-type check valve in each outlet branch unless such connection is at the

Reference Standard 17

shore end of a standpipe system also supplied by a siamese hose connection of the type specified for fireboat use.

(2) Siamese connections for fireboat use shall have two 3 1/2 in. swivels with fire department female threads. All other siamese hose connections, except those of the shore end type, shall have two 3 in. swivels with fire department female threads.

(3) All shore end siamese connections shall have 3 in. male hose threads and shall be subject to the approval of the fire department. In lieu of a check valve, each branch may have a drip and a long stem valve, which shall be located within the structure or otherwise protected against freezing. No siamese connections provided for fireboat use shall be installed in any standpipe system whose water supply is taken from the city water mains.

(b) Marking.-Each siamese connection shall be provided with caps painted red, and shall have the word "STANDPIPE" in letters 1 in. high and 1/8 in. deep cast in the body or on a nonferrous metal plate secured to the connection or mounted on the wall in a visible location, except that caps of each siamese connection used for combination standpipe and sprinkler systems shall be painted yellow and the words shall read

"COMBINATION STANDPIPE AND SPRINKLER SYSTEMS".

(c) Location.-

(1) Siamese connections shall be placed between 18 in. and 36 in. above the sidewalk level.

(2) Siamese connections shall be of the flush or free standing type, and with the exception of the swivel caps, shall not project beyond the street property line. The riser pipe to a free standing siamese connection shall be red brass. When siamese connections are installed in wall recesses, the recesses shall be of ample size to permit convenient hose attachment.

(d) Check valve.-Each siamese connection shall be provided with a swing-type check valve inside of the building or in a valve pit outside of the building.

(e) Drip valve.-A 3/4 in. automatic ball drip valve shall be placed between the siamese connection and the check valve, except that on a fireboat siamese connection, a 1/2 in. open drip without a shutoff may be used. Automatic ball drips shall be placed in the horizontal position.

**Local Law 5-1973*

3. Hose Stations.-

(a) Hose outlet valves.-

(1) On each floor at each riser, the required 2 1/2 in. angle hose valve shall be of a class as indicated in Table RS 17-1-1.

(2) At the top of the highest riser there shall be provided, above the main roof level, a three way manifold equipped with three 2 1/2 in. hose valves with hose valve caps. The lowest valve shall be located with the hose end at least 18 in. above the roof and the highest valve with the hose end not more than 60 in. above the roof. The manifold may be set in a horizontal or

vertical position, provided the hose outlets are set back between 18 in. and 60 in. above the roof level.

(3) Where the manifold is located other than within a heated stair enclosure, the control valve shall be located in a horizontal run of piping below the roof, with a long stem extending through the roof and equipped with a wheel handle at its upper end at least 12 in. above the roof. Between the control valve and the manifold there shall be provided within the heated space a 1/2 in. open drip or a 3/4 in. automatic ball drip, with the drip pipe extended to spill over a plumbing fixture or drain.

(b) Stations within stair enclosures.-

(1) In occupancies where a 2 1/2 in. fire hose is mandatory, the hose shall be connected to the 2 1/2 in. hose valve within the stair enclosure.

(2) In occupancies where 1 1/2 in. fire hose is permitted, a 2 1/2 in. x 1 1/2 in. brass or bronze non-swivel reducing coupling shall be attached to the 2 1/2 in. hose valve or an auxiliary hose station may be provided.

(c) Branch sizes to hose stations.-

(1) The branch size shall be predicated on the developed length from the riser or cross connection to the required 2 1/2 in. hose valve station as follows:

Up to 4 ft. - 2 1/2 in.

Over 4 ft.- 3 in. to 25 ft.

Over 25 ft. - 4 in.

(2) No valve shall be placed between the hose station valve and the riser or cross connection, except that on branches that serve three (3) or more hose stations, a valve shall be provided at the riser or cross connection.

(3) Not more than one (1) hose outlet shall be supplied from a 2 1/2 in. or 3 in. branch.

(d) Auxiliary hose stations branch size.-

(1) Branch piping from the required riser to an auxiliary hose station may be 2 1/2 in. I.P.S., and no valve shall be installed in the branch pipe with the exception of the 1 1/2 in. hose valve at the auxiliary hose station.

(e) Size, type and quality of hose.-

(1) At each hose station, hose shall be provided of a size, type and quality as required by the provisions of the building code.

(2) Hose couplings shall be of brass construction or approved equivalent materials with Fire Department threads.

(f) Nozzles.-

(1) Nozzles on 2 1/2 in. hose, except for yard hydrants, shall be at least 15 in. in length, and shall have a smooth bore with a 1 in. or 1 1/8 in. discharge orifice.

(2) Nozzles for hose used on yard hydrant systems shall be equipped with a playpipe conforming to the requirements of the Fire Department.

(3) Where 1 1/2 in. hose is within the stair enclosure, the nozzle may be a 1/2 in. smooth bore nozzle at least 12 in. in length or an adjustable combination fog nozzle.

(4) Nozzles at auxiliary hose stations shall be Fire Department approved adjustable combination fog nozzles.

(5) All nozzles shall be of brass, cast iron, aluminum or

Reference Standard 17

approved equivalent materials with Fire Department threads.

(g) Hose and valve cabinets.-

(1) When the hose is kept in a cabinet, such cabinet shall be equipped with a single swinging door that shall have at least an 8 in. high panel of clear wired glass at the level of the hose valve and rack. The door width shall be the full inside width of the cabinet, and the glass panel shall be at least 90 percent of the width of the door. Where an extinguisher or other appurtenance are installed within the cabinet, the door shall have clear wire glass panel the full 90 percent of the door areas.

(2) The hose valve within a stair enclosure may be kept in a cabinet. Such cabinet shall be equipped with a single swinging door that shall have a clear wired glass panel 90 percent of the door area. The valve shall be placed in the cabinet to permit coupling of 2 1/2 in. hose to the valve without causing kinks in the hose.

(3) Each cabinet shall be readily accessible and the door shall be kept unlocked.

(4) Cabinets may have solid metal doors when located in the entrance hall of a building. All such hose cabinets or closets shall be permanently marked "FIRE HOSE" across the door panel in red letters at least 1 in. high and shall not be used for any other purpose but concealing the hose station.

(h) Hose rack.-

(1) The hose at each outlet shall be kept upon a hose rack firmly supported and placed between 5 ft. and 6 ft.-6 in. above the floor or landing.

(2) The use of dump or reel-type racks is prohibited.

4. Tanks in Standpipe System.-

(a) Construction and support of tanks.-Tanks for the standpipe system supply shall be constructed and supported in accordance with the provisions of Reference Standard RS 16, Reference Standard RS 17-2, and applicable provisions of the building code for loads and structural work.

(b) Combination tanks.-Gravity tanks may be used to provide the required primary water supply to the standpipe system and may also be used to supply automatic sprinkler and/or domestic water in a building provided all the following conditions are met:

^{*}(1) The connections to the tank are made in such a manner as to provide the required sprinkler and/or fire standpipe reserve. The domestic supply is above the sprinkler and/or standpipe reserve. The standpipe reserve is above the sprinkler reserve. Where a standpipe riser is used to supply water to a combination sprinkler and standpipe system as permitted, the connection to the tank shall be made in such a manner as to provide the required sprinkler or standpipe reserve, whichever is greater.

**Local Law 5-1973*

(2) The connections to the system are made outside of the tank. When connections or piping are installed inside

the tank, the piping shall be assembled without couplings and shall be of red brass or approved equivalent material in accordance with Reference Standard RS-16.

(3) The tank is filled by means of an automatic pump at a rate of not less than 65 gpm.

(c) Filling of tanks.-

(1) Pressure or gravity tanks shall be filled at the rate of at least 65 gpm. Pipes used to fill the tanks shall not be used for any other purpose; nor shall required fire pumps be used for filling purposes.

(2) Where there is sufficient pressure in the city water main to fill tanks at the required rate during all hours of each day, and a filling pump is not provided, the connection to the city water supply shall be made near the point where the city water service enters the building.

^{**}(3) A combined fire standpipe reserve and domestic water tank shall only be filled by direct public water connection or separate fill pumps, or direct connection to equipment, or pumps used to supply domestic water systems in accordance with Reference Standard RS-16.

(d) Emergency Drains on standpipe tanks.-Each standpipe tank shall be provided with a drain of at least 4 in. National Pipe Thread. Each drain pipe shall be controlled by a manually operated gate valve located so as to be readily accessible. The drain shall be installed in accordance with the provisions of Reference Standard RS-16.

(e) Heating of standpipe tanks.-

(1) Where the water in the tank is subject to freezing, the tank shall be equipped with a tank heater in accordance with the provisions of Reference Standard RS 17-10.

(2) Where the standpipe supply and domestic water supply are combined in a single tank, heating of such tank shall not be required in hotels, multiple dwellings, hospitals, or other occupancies where the domestic supply is drawn upon during all hours of every day of the week.

(f) Strainer.-

(1) Every standpipe gravity or suction tank shall be provided with a brass or bronze strainer at the discharge to risers or to pump supply lines.

(2) Each strainer shall have clear openings with an aggregate area equal to, or more than, the required area of the pipe into which the tank discharges. Openings shall be not more than 1 in. nor less than 1/2 in. in diameter.

(g) Overflow pipe for standpipe tanks.-Each gravity standpipe tank shall be provided with an overflow in accordance with the provisions of reference standard RS 16.

(h) Access to standpipe tanks.-Access to the top of each gravity tank shall be by means of a steel, wrought iron or approved equivalent material gooseneck ladder, constructed of flat side bars at least 2 in. by 3/8 in, or equivalent, spaced at least 14 in. apart, with round or square rungs at least 5/8 in. thick spaced not more than 12 in. on centers. The ladder shall be rigidly braced and shall not tip outward from the vertical at any point.

Reference Standard 17

When ladders exceed 25 ft. in height, body irons spaced not more than 2 ft. on center and a metal platform at least 14 in. square, rigidly secured to the stringers of the ladder or other type of enclosed safe access, shall be provided near the top of the tank.

(i) Tank alarms for standpipe systems.-

(1) Gravity tanks not filled by an automatic pump or by city pressure shall be equipped with a high and low water level electrical alarm system.

(2) All pressure tanks used to provide the required primary water supply of a standpipe system shall be equipped with a high and low air pressure and a high and low water level electrical alarm system. Air-to-water ratio shall be 1 to 2 by volume and may be maintained by automatic electrical controls.

****384-82 BCR**

5. Fire Pumps in Standpipe Systems.-

*** (a) Installation of standpipe fire pumps.-

(1) Fire pumps shall be placed on concrete pads at least 12 in. above the pump room floor with a clearance of at least 3 ft. maintained on all sides from walls or from other equipment in the pump room. In the event of the use of a vertical shaft centrifugal fire pump, the 12 in. high concrete pad may be omitted, provided the bottom of the electric driving motor and all electrical appurtenances are raised at least 12 in. above the pump room floor.

(2) The control of the manually operated fire pump shall be designed to operate at predetermined speeds to give pressure increments of 50 psig. The first step of the starter shall provide 100 psig at the pump, and each succeeding step shall produce increments of 50 psig up to the required pump pressure.

(3) Each automatic fire pump shall be equipped with a 3 in. National Pipe Thread pressure relief valve installed in the pump discharge. Such relief valve shall be set to relieve below the shutoff head of the pump, but above the pressure required to maintain the operating pressure at the highest hose valve. The discharge from the relief valve may be piped back into the suction side of the pump on the pump side of the suction valve provided a visual sight glass is installed in the discharge of the relief valve. Automatic fire pumps may be provided with a time delay switch to insure a minimum running time for the pump.

(4) Each manually operated fire pump shall be equipped with a 3 in. National Pipe Thread pressure relief valve for 500 gpm pumps and a 4 in. National Pipe Thread pressure relief valve for 750 gpm pumps. The relief shall be installed in the pump discharge line and set to relieve at a pressure not to exceed 15 lb. over the pressure required to deliver the rate capacity of the pump at the highest hose outlet. Discharge of the relief valve may be piped back into the suction side of the pump on

the pump side of the suction valve provided a visual sight glass is installed in the discharge of the relief valve.

(5) Each manually operated pump shall be equipped with a test valve installed in the pump discharge line that may be connected to the discharge side of the relief valve if the discharge pipe is piped back to the suction side of the pump as provided in (4) above. The size of the test line shall be 3 in. National Pipe Thread for a 500 gpm pump and 4 in. National Pipe Thread for a 750 gpm pump.

(6) The check valves in the pump discharge line shall be either swing type or spring loaded.

*** (b) Wiring for fire pumps.-

(1) When the fire pump feeder conductors are routed through the building(s), they shall be enclosed by two (2) inches of concrete or shall be listed electrical circuit protective systems with a minimum of one-hour fire resistance.

*****177-72 BCR; 1014-80 BCR**

****DOB 7-24-96**

***310-90 BCR**

* REFERENCE STANDARD RS 17-2

** ANSI/NFiPA No. 13 – 1989

STANDARD FOR THE INSTALLATION OF SPRINKLER SYSTEMS

The provisions of NFiPA No. 13 – 1989 shall be subject to the following modifications. The section and paragraph numbers are from that standard.

****DOB 6-26-99**

CHAPTER 1-General Information

1-1 Delete.

1-4 Delete.

1-6 Delete.

1-7 Classification of Occupancies

Add 1-7.5 For purposes related to sprinkler installation, classification of occupancies in paragraphs 1-7.2.1, 1-7.3.1, 1-7.3.2, 1-7.3.3 and 1-7.4.1 shall be considered as equivalent to classifications of buildings and spaces in the building code as follows:

Light Hazard-E, G, H-1, H-2, J-1, J-2, J-3

Ordinary Hazard-B-1, B-2, D-1, D-2, C, F-1, F-3, F-4 except restaurant and cafeteria seating areas, shall be considered light hazard. Conference rooms and auditorium spaces related to Class E occupancies shall be considered light hazard.

Extra Hazard-A

1-9 Delete.

1-10 Delete.

1-11.1 Delete.

1-11.2 Delete except for 1-11.2.4 and 1-11.2.5

1-11.3 Delete.

1-12 Delete.

CHAPTER 2-Water Supplies

Reference Standard 17

2-1 Delete.

Revise table 2-2.1 (a) and notes to read as follows:

**TABLE 2-2.1.1(a)
GUIDE TO WATER SUPPLY REQUIREMENTS FOR
PIPE SCHEDULE SPRINKLER SYSTEMS**

| Occupancy Classification | Residual Pressure Required (See Note 1) | Acceptable Flow at Base of Riser (See Note 2) | Duration in Minutes (See Notes 3, 4 & 5) |
|------------------------------------|--|---|--|
| Light Hazard | 15 psi | 500-750 gpm | 30 |
| Ordinary Hazard (Group 1) | 15 psi or higher | 700-1000 gpm | 40 |
| Ordinary Hazard (Group 2) | 15 psi or higher | 850-1500 gpm | 40 |
| Ordinary Hazard (Group 3) | Pressure and flow requirements for sprinklers and hose streams to be determined from Table 2-2.1.1 (b) | | 40 |
| Warehouses (See Note 6) | Pressure and flow requirements as determined by Chapter 7 and subject to Commissioner's approval. | | |
| High Rise Buildings | Pressure and flow requirements for sprinklers in accordance with Table 2-2.1.1(b). | | |
| Woodworker's Shop - See Appendix A | Pressure and flow requirements subject to Commissioner's approval. | | |
| Extra Hazard | Pressure and flow requirements subject to Commissioner's approval. | | |

Notes:

1. The pressure required at the base of the sprinkler(s) is defined as the residual pressure required of the elevation at the highest sprinkler plus the pressure required to reach this elevation.
2. The lower figure is the minimum flow ordinarily acceptable for pipe schedule sprinkler systems. The higher flow should normally suffice for all cases under each group.
3. Where there is a requirement for a sprinkler alarm, a central station signal shall be provided.
4. In existing buildings only, the Commissioner may authorize reduction of storage to 20 minutes provided there are provisions for acceptable mechanical automatic means of makeup to the storage tank.
The following conditions should be met for determining acceptable means for makeup:
 - a) Automatic means of makeup for a tank fire reserve should be capable of pumping water into the tank at a rate, for a period of 20 minutes, sufficient to equal the difference between the normal 30-minute demand and the alternate 20-minute demand. The demand required is established by calculations for the "most demanding remote area" from the riser as shown by examples of Appendix A of NFPA 13-1989 and as now determined for the 30-minute demand.
 - b) There should be at least two (2) automatic means of makeup, each having the same capacity, so that in the event a unit must be removed for repairs the other unit can be placed in service.
 - c) An approved low water alarm is to be provided and located at a point 500 gallons above the available fire reserve level.
5. Where the water supply to a system sized in accordance with the pipe sizing schedules is taken from a water storage tank, the adequacy of the tank capacity shall be verified with a hydraulic calculation.
6. This occupancy classification shall apply when the warehouse contains high-piled or rack storage as defined in Section 4-1.3.10 and complies with the requirements of NFPA 231 and 231C.

Reference Standard 17

***Delete Table 2-2.1 (b) in its entirety, except for Density Curves and add the following:**

TABLE 2-2.1.1(b)

TABLE AND DESIGN CURVES FOR DETERMINING DENSITY, AREA OF SPRINKLER OPERATION AND WATER SUPPLY REQUIREMENTS FOR HYDRAULICALLY DESIGNED SPRINKLER SYSTEMS

Minimum Water Supply Requirements

| Hazard Classification | Sprinklers Only-gpm | Duration in Minutes (See Notes 1, 2, & 3) |
|------------------------------|----------------------------|--|
| Light | See 2-2.1.3 | 30 |
| Ord.-Gp. 1 | See 2-2.1.3 | 40 |
| Ord.-Gp. 2 | See 2-2.1.3 | 40 |
| Ord.-Gp. 3 | See 2-2.1.3 | 40 |

For SI Units: 1 gpm = 3.785 L/min.

Notes:

1. In existing buildings only, the Commissioner may authorize reduction of storage to 20 minutes provided there are provisions for acceptable mechanical automatic means of makeup to the storage tank. Where 20 minutes storage cannot be achieved with existing storage facilities, alternative means of supply may be considered by the Commissioner. In any event, no fire reserve storage facility shall have less than 3500 gallons.

The following conditions should be met for determining acceptable automatic means of makeup:

a) Automatic means of makeup for a tank fire reserve should be capable of pumping water into the tank at a rate, for a period of 20-minutes, sufficient to equal the difference between the normal 30-minute demand and the alternate 20-minute demand. The demand required is established by calculations for the most demanding remote area from the riser as shown by examples of Appendix A of NFPA 13-1989 and as now determined by the 30-minute demand.

b) There should be at least two (2) automatic means of makeup, each having the same capacity, so that in the event that a unit must be removed for repairs the other unit can be placed in service.

c) An approved low water alarm is to be provided and located at a point 500 gallons above the fire level reserve.

2. Where there is a requirement for a sprinkler alarm, a central station signal shall be provided.

3. In no case shall existing sprinkler storage capacities be reduced to less than the amount required for comparable new construction.

4. In fully sprinklered buildings the storage capacity of the fire reserve in the tank shall be as required for the sprinkler demand, but shall not be less than 3500 gallons in buildings with a single fire standpipe riser nor less than 5000 gallons in buildings with multiple fire standpipe risers.

5. Storage in light hazard occupancies where not more than 15 percent of the building is of ordinary hazard may have storage capacity predicated on light hazard occupancy provided that any such space shall not exceed 5,000 square feet in area.

***633-83 BCR**

2-2.4.1 to 2-2.4.6 Delete Except 2-2.4.3

2-3 Connections of Water Works Systems.

2-3.1.2 Delete.

2-4 Gravity Tanks.

2-4.2 Add an additional sentence to read as follows: "If any of the sprinkler heads are supplied from domestic water tanks, the combined water supply in the tank shall be at least 5,000 gallons. Further, that the sprinkler supply shall be taken from the lowest level of the tank."

Add 2-4.3 Combined Use. In E, F, G, H and J Occupancies, with only limited ordinary hazard areas, the sprinkler and standpipe reserve may be common to both. Reserve shall be sized for the greater demand.

Interpretations: Limited, may be defined as less than 30% of the floor area.

Add 2-4.3.1 Buildings whose occupancies are more than 85 percent light hazard, may have a light hazard water supply provided the ordinary hazard areas are designed for ordinary hazard requirements in respect to sprinkler spacing and pipe sizing.

Add 2-4.3.2 Combined standpipe and sprinkler systems may be used in D-2 Laboratory Occupancies, E, F, G, H and J. If an automatic fire pump is used as the primary supply, the requirements of 2-5.3 shall be complied with.

2-5 Pumps

Add 2-5.3 Combined Use. In light hazard occupancies with only limited ordinary hazard areas, an automatic fire pump serving the lower 300 feet of the standpipe system may be used as the primary supply to the sprinkler system, provided that a secondary power supply is available to drive the pump; and such power supply shall be automatic switching.

Add 2-5.4 In hydraulically designed sprinkler systems supplied from a gravity tank, the pressure may be increased by means of an automatic, special service fire pump. The pump shall be sized to satisfy the requirements of Table 2-2.1.1(a) or Table 2-2.1.1(b) and shall be arranged in a bypass to permit the portion of the system so supplied to be served by the system's siamese connections.

(a) If the pump is not supplied from the street side of the building service switch, the electrical service and pump operation shall be fully supervised; provided that a secondary power supply is available to drive the pumps and such power supply shall be automatic switching.

*2-5.5 Wiring for fire pumps. When the fire pump feeder conductors are routed through the building(s), they shall be enclosed by two (2) inches of concrete or shall be listed electrical circuit protective systems with a minimum of one-hour fire resistance.

***DOB 7-24-96**

Reference Standard 17

2-6 Pressure Tanks

Delete 2-6.1 to 2-6.3 and substitute:

2-6.1 Acceptability.

2-6.1.1 A pressure tank in accordance with Table 2-2.1.1(a) or 2-2.1.1(b) is an acceptable water supply source. The total available quantity of water in pressure tanks need not exceed 15,000 gallons when there is a secondary source of water supply available from a gravity tank or a street connection acceptable to the Commissioner of Buildings. The maximum gross capacity of a single pressure tank shall be 9,000 gallons and shall include the needed extra capacity to fill dry-pipe or preaction systems when installed.

2-6.1.2 Each tank shall be kept at a maximum of 2/3 full of water and a minimum of 1/3 full of air maintained under a minimum pressure of 75 psig. The water-to-air ratio shall be so proportioned and the tank so located that a minimum pressure of 15 psig will be available on the highest line of sprinklers below the main roof when all the water is being discharged from the tank.

2-6.1.3 The tank supports shall be designed on the basis of the tank being full of water.

2-6.2 The tanks shall be supplied with water through a fixed pipe, independent of the sprinkler piping and at least 2 inch in size. The water supply shall be capable of supplying the tank at a rate of at least 65 gpm without decreasing the pressure in the tank. The tank shall have a fixed water level plate on the end of the tank opposite the gage glass, or equivalent devices, to indicate the level of the water in the tank.

2-6.3 The air compressor shall be provided with automatic controls for maintaining the air pressure. The capacity of the compressor shall be sufficient to build up the tank pressure to 75 psig within 3 hr. or less.

2-6.4 Pressure tanks shall be provided with approved closed circuit high and low water and high and low air pressure alarms.

2-6.5 Pressure tanks shall be located at or above the top level of sprinklers.

2-7 Delete.

2-8 Delete.

CHAPTER 3-System Components

3-1.1 Delete

3-1.1.1 Delete

3-1.1.4 Delete

3-1.1.5 Delete

Add the following, in lieu of the above:

Piping Specifications.

3-1.1 Pipe or tube used in sprinkler systems shall be welded and seamless steel, wrought steel, wrought iron, drawn seamless copper tube or threadless copper pipe.

The chemical and physical properties of wrought steel or wrought iron pipe should be at least equal to those manufactured in accordance with the specifications of the American Society for Testing and Materials for Black and Hot-Dipped Zinc-Coated (Galvanized) Welded and Seamless Steel-Pipe for Ordinary uses.

ANSI/ASTM Designation A120-80; Welded and Seamless Steel Pipe ANSI/ASTM Designation A53-79; ASTM Designation A72-68.

Dimensions for wrought steel or wrought iron pipe should be in accordance with the American Standard for Wrought Steel and Wrought Iron Pipe, ANSI B36.10-1979. Pipe used in sprinkler systems should be designed to withstand a working pressure of not less than 175 psig. It is intended that this sprinkler standard permit the use of "standard wall" pipe as described in ANSI B36.10-1979 for pressure up to 300 psig. Schedule 40 pipe is considered "standard wall" pipe. Schedule 30 pipe is acceptable in sizes 8 inches and larger. However, "light wall" schedule 10 pipe is acceptable in sizes 10 inches and smaller, provided that the piping is designed to withstand a working pressure of not less than 175 psig, when approved.

Tube or threadless pipe used in sprinkler systems shall be drawn seamless copper tube or threadless copper pipe conforming to the chemical and physical properties of one of the following standards issued by the American Society for Testing and Materials:

Seamless Copper Tube ANSI/ASTM *B75-79

Seamless Copper Water Tube ANSI/ASTM B88-76

General Requirements for Wrought Seamless Copper and

Copper-Alloy Tube ANSI/ASTM B251 M-79

Threadless Copper Pipe ANSI/ASTM B302-76

Copper Tube or threadless pipe used in sprinkler systems as specified in the above standards shall be limited to wet systems for light and ordinary hazard occupancies using sprinkler heads having 165° F rating or less, and shall have minimum wall thickness capable of withstanding a working pressure of not less than 175 psig at a service temperature of 300° F for both annealed and drawn tempers.

Copper Water Tube Types K and L ANSI/ASTM B88-76, and Threadless Copper Pipe Type TP, ANSI/ASTM B302-76.

Copper Pipe Type TP, ANSI/ASTM B302-76. Ferrous Piping (Welded and Seamless), ANSI/ASTM A 135-79 Specification for Electric-Resistance Welded Steel Pipe, pursuant to Board of Standards & Appeals Calendar No. 75-77-SA are acceptable.

Other approved types of pipe or tube may be used, but only those investigated and listed for this service by a nationally recognized testing and inspection agency and acceptable to the Commissioner. The use of pipe or tube other than that described above must involve consideration of many factors, e.g.,

**As enacted but "B75-81" probably intended.*

1. Pressure rating.

Reference Standard 17

2. Beam strength (hangers).
3. Corrosion (Chemical and electrolytic).
4. Resistance to failure when exposed to elevated temperatures.
5. Methods of joining (strength, permanence, fire hazard).
6. Availability of fittings (for sprinkler outlets and proper routings).
7. Toxicity.

3-1.1.5 Delete, and substitute the following:

3-1.1.5 Other types of pipe or tube may be used, but only those investigated and listed for this service by a nationally recognized testing and inspection agency acceptable to the Commissioner. The use of pipe or tube other than that described above must involve consideration of many factors, e.g.

1. Pressure rating
2. Beam strength (hangers)
3. Corrosion (chemical and electrolytic)
4. Resistance to failure when exposed to elevated temperatures
5. Methods of joining (strength, permanence, fire hazard)
6. Availability of fittings (for sprinkler outlets and proper routings)
7. Physical characteristics related to integrity during earthquakes.
8. Toxicity
9. Combustibility
10. Movement during sprinkler operation (water distribution).

3-2 Definitions. Add the following: Fire Section-See sub-article 201.0. Each floor of a sprinklered building may be considered a fire section.

Add 3-3.4.1 In altering existing sprinkler systems which contain 3/4-inch pipe, the existing 3/4-inch pipe may be retained except that extension from such 3/4-inch pipe shall be made using pipe having a minimum diameter of one-inch.

3-3.7 One and One-Half-Inch Hose Connections. Delete.

3-3.8 Hose Connections For Fire Department Use. Delete. Add the following in lieu of the above:

3-3.7 Fire Standpipe Hose Connections. Where permitted in E, F, G, H and J occupancies by Section 2-4.3, and where permitted by the Commissioner, the sprinkler systems may be connected to the distribution system of mains and risers serving the required standpipe hose connections. Connections to the common sprinkler and standpipe systems shall be valved and fitted with an approved supervised tamper switch and flow detector.

3-3.1 Delete the first sentence and add the following:

"The maximum floor area to be protected by a single riser, from a control and alarm device, on any one floor shall be as follows:"

3-4 Pipe Schedules

3-4.1.1 Delete-Add the following:

3-4.1.1 A test pipe of not less than 1-inch diameter terminating in a smooth bore corrosion resistant outlet giving a flow equivalent to one sprinkler shall be provided. This test pipe shall be provided for each

system through a pipe not less than 1-inch in diameter, in the upper story, and the connection should preferably be piped from the end of the most remote branch line. The discharge should be at a point where it can be readily observed. In locations where it is not practical to terminate the test pipe outside the building, the test pipe may terminate in a drain. In this event, the test connection shall be made using an approved sight test connection containing a smooth bore corrosion resistant orifice giving a flow equivalent to one sprinkler. The test valve shall be located at an accessible point, and preferably not over seven feet above the floor. The control valve on the test connection shall be located at a point not exposed to freezing.

Add 3-4.4.1 In buildings having mezzanine floors, large platforms, or large openings between floors which cannot be closed or satisfactorily cut off, the possibility that all or most of the sprinklers might be opened by a single fire should be considered in determining the size of risers. Where occupancy and construction are exceptionally good and where there is little likelihood of a fire spreading beyond the vicinity of its origin, the size of the feed main should be based on the total number of sprinklers in the main area plus half the number in the area not cut off. A sprinkler water, curtain may be considered an exceptionable cut off for openings of less than 1000 square feet.

Add 3-4.6 Sizes for Domestic Water Piping. Where permitted by the building code, 10 or less heads, that are connected to the domestic water system shall have the piping sized in accordance with the tables herein and the domestic water line to which the sprinkler line connected thereto. Connections may be made directly to cross-connections or headers.

3-6.2.3 Delete first sentence and change to read: Each interior sectional or floor control valve shall be provided with a drain connection sized as shown in Table 3-6.2.3 so as to drain that portion of the system controlled by the sectional or floor valve.

Table 3-6.2.3

| Sectional or Floor Valve Size | Minimum Size of Drain Connection |
|--------------------------------------|---|
| Up to 2 1/2 in. | 1-in. |
| 3-in., 3 1/2-in., 4-in. | 1 1/4 in. |
| 5-in. and 6-in. | 1 1/2-in. |
| 8-in. | 2-in. |

Delete Section 3-7.4 and substitute the following:

3-7.4 Joints for the connection of copper tube or threadless pipe shall be brazed. Brazing filler metal classed BCuP-3, BCuP-5, BAG-2 (ANSI/AWS A5.8-89) may be used.

Add Lead free solder joints may be permitted for wet pipe systems in Light Hazard Occupancies when the temperature classification of the installed sprinklers is Ordinary or Intermediate.

Reference Standard 17

3-8 Fittings

Re-number Section 3-8.1.4 to 3-8.1.6

Re-number Section 3-8.1.5 to 3-8.1.7

Add a new Section 3-8.1.4 to read as follows:

3-8.1.4 Fittings used in the assembly of copper tube shall conform to the following standards issued by the American National Standards Institute:

Bronze Flanges and Flanged Fittings
150 to 300 lb. ANSI B16.24-79

Add a new section 3-8.1.5 to read as follows:

3-8.1.5 Fittings used in the assembly of threadless copper pipe (Type TP) shall conform to the following standards:

Cast Bronze, Brazed-Joint Pressure Fittings

Dimensions MIL F-1183 J-87

Chemical and physical properties ANSI/ASTM B61-86 or
ANSI/ASTM B62-86

Bronze Flanges and Flanged Fittings

150 and 300 lb. ANSI B16.24-79

3-8.6 One and One-Half-Inch Hose Connections. Delete.

3-8.7 Hose Connections for Fire Department Use. Delete.

Add the following in lieu of the above.

3-8.7 Fire Standpipe Hose Connections. Where permitted in E, F, G, H and J Occupancies by Section 2-4.3 and where permitted by the Commissioner, the sprinkler system may be connected to the distribution system of mains and risers serving the required standpipe hose connections. Connections to the common sprinkler and standpipe systems shall be valved and fitted with an approved supervised tamper switch and flow detector.

3-9 Valves

3-9.1.1 Delete-Add the following:

3-9.1.1 A test pipe of not less than 1-inch diameter terminating in a smooth bore corrosion resistant outlet giving a flow equivalent to one sprinkler shall be provided. This test pipe shall be provided for each system through a pipe not less than 1 inch in diameter in the upper story, and the connection should preferably be piped from the end of the most remote branch line. The discharge should be at a point where it can be readily observed. In locations where it is not practical to terminate the test pipe outside the building, the test pipe may terminate into a drain. In this event, the test connection shall be made using an approved sight test connection containing a smooth bore corrosion resistant orifice giving a flow equivalent to one sprinkler. The test valve shall be located at an accessible point and preferably not over seven feet above the floor. The control valve on the test connection shall be located at a point not exposed to freezing.

3-9.1.1 Add the following sentence:

An approved indicating shutoff valve may be used in lieu of an O.S.&Y. gate valve wherever referred to in these modifications except such valve shall not be part of the pressure reducing valve. The indicator shall be readily visible from the floor.

3-9.2 Valves Controlling Sprinkler Systems.

3-9.2.3 Delete exception #2.

3-9.2.5 Delete.

3-9.2.6 Delete.

3-9.2.7 Delete.

Add 3-9.2.5 Where there is one water supply connection a check valve shall be installed. Such check valve may be a swing check, an approved fire meter or an approved detector check.

Add 3-9.2.6 Where a system having only one dry-pipe valve is supplied with city water and Fire Department connection, it will be satisfactory to install the main check valve in water supply connection in a vertical position immediately inside of the building after the main indicating valve.

Add 3-9.2.7 Where either a wet or dry pipe sprinkler system is supplied by city water and a Fire Department connection and has more than one riser with O.S.&Y. gate valve in each, and the whole system is controlled by one outside post indicator valve, it will be satisfactory to install the main check valve in the water supply connection immediately inside building. If the supply is controlled by an underground gate valve with a Department of Environmental Protection standard roadway box, the main check valve in the water supply connection should be installed immediately after the O.S.&Y. gate valve inside the building.

Add 3-9.2.8 Where a wet pipe sprinkler system is supplied by city water and a Fire Department connection with only one riser, the alarm valve will be considered as a check valve and an additional check will not be required.

Add 3-9.2.9 A gate valve should be installed on each side of each check valve under conditions other than described in Paragraphs 3-9.2.6, 3-9.2.7 and 3-9.2.8. However, this shall not apply to Fire Department Siamese check valves.

Add 3-9.2.10 Where a gravity tank is located on a tower in the yard, the gate valve on the tank side of the check valve shall be of O.S.&Y. type; the other shall be either an O.S.&Y. valve or an indicator post valve. Where a gravity tank is located on a building, both gate valves shall be the O.S.&Y. type; and all fittings inside the buildings, except the drain tee fill line, and heater connections, shall be under the control of a gate valve.

Add 3-9.2.11 In a city connection serving as one source of supply the city valve in the connection may serve as one of the required gate valves. An O.S.&Y. valve or an indicator post valve should be installed on the systems (water supply) side of the check valve.

Add 3-9.2.12 A connection from public water system shall not extend into or through a building unless such connection is under the control of an outside indicator post or O.S.&Y. gate or under the control of an inside O.S.&Y. gate valve located near the outside wall of the building.

Add 3-9.2.13 When a pump, located in a combustible pump house or exposed to danger from fire or falling walls, or a tank discharges into a yard main valve, fed by another supply, either the check valve in the connection shall be located in a pit or the gate valve should be of the indicator post type, located a safe

Reference Standard 17

distance outside of buildings.

Add 3-9.2.14 Check valves on tank or pump connections, when located underground, may be placed inside of buildings and at a safe distance from the tank riser or pump, except in cases where the building is entirely of one fire area, when it is ordinarily considered satisfactory to locate the check valve over-head in the lowest level.

Add 3-9.2.15 All gate valves controlling water supplied for sprinklers shall be located where readily accessible and when necessary, permanent ladders, clamped treads on risers, chains and wheels, or other accepted means should be provided.

Add 3-9.2.16 Section Valves in Underground Fire Mains. Large yard systems shall have section controlling valves at appropriate points, in order to permit sectionalizing the system in the event of a break, or for the making of repairs or extension (See Standard for Outside Protection, ANSI/NFPA No. 24-87).

Add 3-9.2.17 Floor Valves. Floor control valves shall be provided where required or in special cases where area or height, or number of tenants is excessive, both in manufacturing and mercantile buildings, or where contents are more than ordinarily susceptible to damage. Floor valves shall be located where they are readily accessible. They are to be O.S.&Y. or indicating type located ahead of the inlet of any pressure reducing valve.

Add 3-9.2.18 Indicator Posts for Gate Valves.

Add 3-9.2.18.1 Outside Control shall be provided.

Add 3-9.2.18.2 Where sprinklers are supplied from a yard main, an approved outside indicator post gate valve shall be placed in the connecting pipe at a safe distance from the building.

Add 3-9.2.18.3 Indicator post valves should be located not less than 40 feet from buildings; but where necessary to place a valve close to a building, it should be located at a blank part of the wall.

Add 3-9.2.18.4 When a building has no basement, and an outside post indicator control cannot be furnished, a short post indicator may be installed in a horizontal position in riser with handwheel projecting outside of wall.

Add 3-9.2.19 Pits for Underground Valves. Pits for underground valves except those located at the base of a tank riser, are described in the Standard for Outside Protection (ANSI/NFPA No. 24-87). For pits protecting valves located at the base of a tank riser, refer to RS-10.

Add 3-9.2.20 Securing of Valves. All gate valves in supply pipes to automatic sprinklers, whether or not of indicator or post pattern, shall be sealed open in a satisfactory manner.

Add 3-9.2.21 Valves controlling sprinkler supplied from the standpipe system shall be approved for standpipe service in the pressure zone in which it is installed. They shall be O.S.&Y. or indicating valves and shall be located ahead of the inlet of any pressure reducing valve installed.

3-9.3.4. Delete.

3-11.5.2 Add to first sentence; and subject to the Commissioner's approval.

3-12.3.2 Delete this Section, and substitute the following:

Dry Pipe Valves. The alarm apparatus for a dry-pipe system shall consist of approved low and high air pressure alarm attachments to the dry-pipe valve. When a dry-pipe valve is located on the system side of an alarm valve, the actuating device of the alarms for the dry-pipe valve may be connected to the alarms on the wet-pipe system.

Delete Section 3-12.4 and the following, in lieu of the above:

3-12.4 Joints for the connection of copper tube or threadless pipe shall be brazed. Brazing filler metal classes BCuP-3, BCuP-5, BAg-2 *(ANSI/AWS A5.8-77) may be used.

**As enacted but "(ANSI/AWS A5.8-76)" probably intended.*

3-12.6 Delete this section and add; refer to RS 17-3

3-12.7 Delete this section and add; refer to RS 17-3

3-12.8 Delete this section, and substitute the following:

Identification Signs. Identification signs shall be provided for outside alarm devices. The sign should be located near the device in a conspicuous position and shall be worded as follows: **"SPRINKLER FIRE ALARM-WHEN BELL RINGS CALL FIRE DEPARTMENT OR POLICE"**.

Add 3-12.9 Drains

Add 3-12.9.1 Where vents are necessary for satisfactory electric alarm switch operations, such vents should be properly piped to a drain.

Add 3-12.9.2 Drains from alarm devices shall be so arranged that there will be no danger of freezing, and so that there will be no overflowing at the alarm apparatus, at domestic connections or elsewhere with the sprinkler drains wide open and under pressure.

Add 3-12.9.3 Drain from retarding chamber and electric alarm switch should preferably discharge through an open cone and be run separate from main system drains to a safe and visible point of free discharge or to sewer or ground drain. Drain from water-motor-operated alarm device may run separately to sewer or ground drain or may be connected to drain from retarding chamber at a point between such sewer and a check valve on this drain, a union or plug being inserted in the drain from the alarm device to permit inspection. Where checks are used they shall be so located as to have the equivalent of at least a four-foot head and shall not be installed in a vertical position.

Add 3-12.9.4 Where drains are conveyed to a sewer, a proper trap shall be provided.

Add 3-12.9.5 Where it is necessary to drain alarm valves outside the wall, an open discharge cone shall be provided inside to break the pipe line so that cold air will not conduct directly into the retarding chamber. Alternately, all drains shall have at least 4 feet of pipe beyond the valves, in a warm area.

3-13 Fittings

Renumber Section 3-13.1.4 to 3-13.1.6

Renumber Section 3-13.1.5 to 3-13.1.7

Add a new Section 3-13.1.4 to read as follows:

3-13.1.4 Fittings used in the assembly of copper tube shall conform to the following standards issued by the American National Standards Institute:

Reference Standard 17

Bronze Flanges and Flanged Fittings

150 to 300 lb. ANSI B16.24-79

Add a new section 3-13.1.5 to read as follows:

3-13.1.5 Fittings used in the assembly of threadless copper pipe (Type TP) shall conform to the following standards:

Cast Bronze, Brazed-Joint Pressure Fittings

Dimensions MIL F-1183 G-78

Chemical and physical properties ANSI/ASTM B61-80 or

ANSI/ASTM B62-80

Bronze Flanges and Flanged Fittings

150 to 300 lb. ANSI B16.24-79

3-14 Valves.

123-14.1.1 Add the following sentence:

"An approved indicating valve may be used in lieu of an O.S.&Y. gate valve wherever referred to in these modifications except where such valve is to be installed in conjunction with a pressure reducing valve."

3-14.2 Valves Controlling Sprinkler Systems.

Amend 3-14.2.1 Each system shall be provided with a listed indicating valve so located as to control all sources of water supply except fire department connections.

3-14.2.5 Delete.

3-14.2.6 Delete.

3-14.2.7 Delete.

Add 3-14.2.5 Where there is one water supply connection, a check valve shall be installed. Such check valve may be a swing check, an approved fire meter or an approved detector check.

Add 3-14.2.6 Where a system having only one dry-pipe valve is supplied with city water and Fire Department connection, it will be satisfactory to install the main check valve in water supply connection in a vertical position immediately inside of the building after the main indicating valve.

Add 3-14.2.7 Where either a wet or dry pipe sprinkler system is supplied by city water and Fire Department connection and has more than one riser with O.S.&Y. gate valve in each and the whole system is controlled by one outside post indicator valve, it will be satisfactory to install the main check valve in the water supply connection immediately inside building. If the supply is controlled by an underground gate valve with an approved roadway box, the main check valve in the water supply connection should be installed immediately after the O.S.&Y. gate valve inside the building.

Add 3-14.2.8 Where a wet pipe sprinkler system is supplied by city water and a Fire Department connection with only one riser, the alarm valve will be considered as a check valve and an additional check will not be required.

Add 3-14.2.9 A gate valve should be installed on each side of each check valve under conditions other than described in Paragraphs 3-14.2.6, 3-14.2.7, 3-14.2.8. However, this shall not apply to Fire Department Siamese check valves.

Add 3-14.2.10 Where a gravity tank is located on a

tower in the yard, the gate valve on the tank side of the check valve shall be of O.S.&Y. type, the other shall be either an O.S.&Y. valve or an indicator post valve.

Where a gravity tank is located on a building both gate valves shall be the O.S.&Y. type; and all fittings inside the buildings, except the drain ice fill line, and heater connections, shall be under the control of a gate valve.

Add 3-14.2.11 In a city connection serving as one source of supply the city valve in the connection may serve as one of the required gate valves. An O.S.&Y. valve or an indicator post valve should be installed on the systems (water supply) side of the check valve.

Add 3-14.2.12 A connection from public water system shall not extend into or through a building unless such connection is under the control of an outside indicator post or O.S.&Y. gate valve or under the control of an inside O.S.&Y. gate valve located near the outside wall of the building.

Add 3-14.2.13 When a pump, located in a combustible pump house or exposed to danger from fire or falling walls, or a tank discharges into a yard main fed by another supply, either the check valve in the connection shall be located in a pit or the gate should be of the indicator post type, located a safe distance outside of buildings.

Add 3-14.2.14 Check valves on tank or pump connections, when located underground, may be placed inside of buildings and at a safe distance from the tank riser or pump, except in cases where the building is entirely of one fire area, when it is ordinarily considered satisfactory to locate the check valve over-head in the lowest level.

Add 3-14.2.15 All gate valves controlling water supplied for sprinklers shall be located where readily accessible and when necessary, permanent ladders, clamped treads on risers, chains and wheels, or other accepted means should be provided.

Add 3-14.2.16 Section Valves in Underground Fire Mains. Large yard systems shall have section controlling valves at appropriate points in order to permit sectionalizing the system in the event of a break, or for the making of repairs or extension. (See Standard for Outside Protection, ANSI/NFPA No. 24)

Add 3-14.2.17 Floor Valves. Floor control valves shall be provided where required or in special cases where area or height, or number of tenants is excessive, both in manufacturing and mercantile buildings, or where contents are more than ordinarily susceptible to damage. Floor valves shall be located where they are readily accessible. They are to be O.S.&Y. type located ahead of the inlet of any pressure reducing valve.

Add 3-14.2.18 Indicator Posts for Gate Valves.

Add 3-14.2.18.1 Outside control shall be provided.

Add 3-14.2.18.2 Where sprinklers are supplied from a yard main, an approved outside indicator post gate valve shall be placed in the connecting pipe at a safe distance from the building.

Add 3-14.2.18.3 Indicator post valves should be located not less than 40 feet from buildings; but where necessary to place a valve close to a building, it should

Reference Standard 17

be located at a blank part of the wall.

Add 3-14.2.18.4 When a building has no basement and an outside post indicator control cannot be furnished, a short post indicator may be installed in a horizontal position in riser with handwheel projecting outside of wall.

Add 3-14.2.19 Pits for Underground Valves. Pits for underground valves except those located at the base of a tank riser are described in the Standard for Outside Protection (ANSI/NFPA No. 24). For pits protecting valves located at the base of a tank riser, refer to the Standard for Water Tanks for Private Fire Protection (ANSI/NFPA No. 22).

Add 3-14.2.20 Securing of Valves. All gate valves in supply pipes to automatic sprinklers, including indicator or post pattern, shall be sealed open in a satisfactory manner.

Add 3-14.2.21 Valves controlling sprinkler supplied from the standpipe system shall be approved for standpipe service in the pressure zone in which it is installed. They shall be O.S.&Y. valves and shall be located ahead of the inlet of any pressure reducing valve installed.

3-15 Hangers

3-15.1.10 Delete this section and substitute the following:

3-15.1.10 Maximum Distance Between Hangers. With Steel Pipe as specified in this chapter, the maximum distance between hangers shall not exceed 12 feet for 1 and 1 1/4 inch sizes nor 15 feet for sizes 1 1/2 inch and larger except as provided in 3-15.6. See Figure A-3-15.1.10.

With copper tube or pipe as specified in this chapter, maximum spacing between hangers shall not exceed the distance indicated on Figure A-3-15.5.4 with steel band and ring hangers confirming therewith.

HANGER SPACE FOR COPPER PIPE AND COPPER TUBE-HORIZONTAL RUN HORIZONTAL RUN HANGER SPACING

| Tube Size | Spacing |
|-------------------|------------|
| 3/4" to 1" | 5-8 feet |
| 1 1/4" and 1 1/2" | 8-10 feet |
| 2" and 3" | 10-12 feet |
| 4"-8" | 12-15 feet |

SIZING OF SPS** STEEL STRAP AND RING HANGERS FOR USE WITH COPPER TUBE SPS Steel Strap or Ring Hanger

| Copper Tube Size inches | Nominal Outside Diameter, inches | Size, inches | Minimum Inside Diameter, inches |
|-------------------------|----------------------------------|--------------|---------------------------------|
| 1/4 | 0.875 | 1/2 or 3/4 | 1.050 or 1.315 |
| 1 | 1.125 | 1/4 or 1 | 1.315 |
| 1 1/4 | 1.375 | 1 | 1.660 |
| 1 1/2 | 1.625 | 1 1/4 | 0.840 |
| 2 | 2.125 | 2 | 2.375 |

*Above 2-inch, use the same SPS hanger size as the tube size.

**Standard Pipe Size Figure A-3-15.5.4.

3-17.3.2 Delete this Section, and substitute the following: Dry Pipe Valves. The alarm apparatus for a dry-pipe system shall consist of approved flow and low and high air alarm

attachments to the dry-pipe valve. When a dry-pipe valve is located on the system side of an alarm valve, the actuating device of the alarms for the dry-pipe valve may be connected to the alarms on the wet-pipe system.

3-17.7 Delete this Section, and substitute the following: Identification Signs. It is essential to provide identification signs for outside alarm devices. The sign should be located near the device in a conspicuous position and shall be worded as follows: "**SPRINKLER FIRE ALARM-WHEN BELL RINGS CALL FIRE DEPARTMENT OR POLICE.**"

Add 3-17.8 Drains.

Add 3-17.8.1 Where vents are necessary for satisfactory electric alarm switch operation, such vents should be properly piped to a drain.

Add 3-17.8.2 Drains from alarm devices shall be so arranged that there will be no danger of freezing and so that there will be no overflowing at the alarm apparatus, at domestic connections or elsewhere with the sprinkler drains wide open and under pressure.

Add 3-17.8.3 Drain from retarding chamber and electric alarm switch should preferably discharge through an open cone and be run separate from main system drains to a safe and visible point of free discharge or to sewer or ground drain. Drain from water-motor-operated alarm device may run separately to sewer or ground drain or may be connected to drain from retarding chamber at a point between such sewer and a check valve on this drain, a union or plug being inserted in the drain from the alarm device to permit inspection. Where checks are used they shall be so located as to have the equivalent of at least a four-foot head and shall not be installed in a vertical position.

Add 3-17.8.4 Where drains are conveyed to a sewer, a proper trap shall be provided.

Add 3-17.8.5 Where necessary to drain alarm valves outside the wall, an open discharge cone shall be provided inside to break the pipe line so that cold will not be conducted directly into the retarding chamber. Alternately, all drains shall have at least four foot of pipe beyond the valves in a warm area.

CHAPTER 4-Spacing, Location and Position of Sprinklers

4-1.2 Delete.

4-2.2.1 Delete the first sentence and add the following: "The maximum floor area to be protected by a single riser, from a control and alarm device, on any one floor shall be as follows:"

4-4.7.1 Delete

4-4.7.2.1 Delete

4-4.7.2.2 Delete

4-4.7.2.3 Add to last sentence:

when required by other sections of this code

Delete the Exception

4-4.7.2.4 Delete

4-4.8 Add the following:

Sprinklers shall be provided in chute vestibules on all floors, if no vestibule exists, then sprinklers shall be provided above chute doors and shall be located no

Reference Standard 17

more than 1-foot horizontally from face of chute door. All building service chute sprinkler systems shall be provided with a local water flow and valve supervisory alarm and be connected to an authorized fire alarm central office.

4-4.8.1 Delete.

4-4.8.2 Delete.

4-4.8.2.4 Delete.

Add 4-4.17.4 Safe deposits or other vaults of fire-resistive construction will not require sprinkler protection when used for the storage of records, files and other documents when stored in metal cabinets.

4-4.8.1 Delete and substitute the following:

In cooking areas protected by automatic sprinklers, sprinklers shall be provided to protect commercial-type cooking equipment and ventilation systems that are designed to carry away grease laden vapors unless otherwise protected (see RS 13-2 and RS 13-3). Sprinklers shall be so located as to give complete coverage of cooking surfaces, within exhaust ducts, within exhaust hood plenum chamber, and under filters, if any.

Add 4-4.16.4 Safe deposits or other vaults of less than 1,000 cubic feet in size of fire-resistive construction may not require sprinkler protection when used for the storage of records, files and other documents, when stored in metal cabinets. These vaults shall be equipped with either a smoke or heat detection system connected to an authorized fire alarm central office.

4-4.17.1 Delete, and substitute the following:

In cooking areas protected by automatic sprinklers, sprinklers shall be provided to protect commercial-type cooking equipment and ventilation systems that are designed to carry away grease laden vapors unless otherwise protected (see RS 13-2 and RS 13-3). Sprinklers shall be so located as to give complete coverage of

cooking surfaces, within exhaust ducts, within exhaust hood plenum chamber, and under filters, if any.

4-4.19.2 Add the following:

and provided that hard wired smoke detectors are provided in the sleeping rooms.

*Add section 4-4.19.4 to follow section 4-4.19.3 as follows:

*4-4.19.4 In buildings and spaces classified in Occupancy Groups J-2 and J-3, sprinklers may be omitted from bathrooms, water closet compartments, general toilet rooms and shower rooms.

Add section 4-4.19.5 to follow section 4-4.19.4 as follows:

*4-4.19.5 In buildings and spaces classified in Occupancy Groups J-2 and J-3, sprinklers may be omitted from clothes closets, linen closets and pantries.

*DOB 6-25-99

CHAPTER 5-Types of Systems

5-3.4 Delete and substitute the following:

Location and Spacing of Fire Detection Devices. Spacing of fire detection devices shall be in accordance with their listing by nationally recognized testing laboratories or in accordance with manufacturer's specifications, subject to the approval of the Commissioner of Buildings.

5-3.5 Delete and substitute the following:

Location and Spacing of Fire Detection Devices. Spacing of fire detection devices shall be in accordance with their listing by a nationally recognized testing laboratory or in accordance with the manufacturer's specifications, subject to the approval of the Commissioner of Buildings.

Fig. 5-5.4 Delete and substitute the following:

Fig. 5-5.4 See detail of Typical Installation.

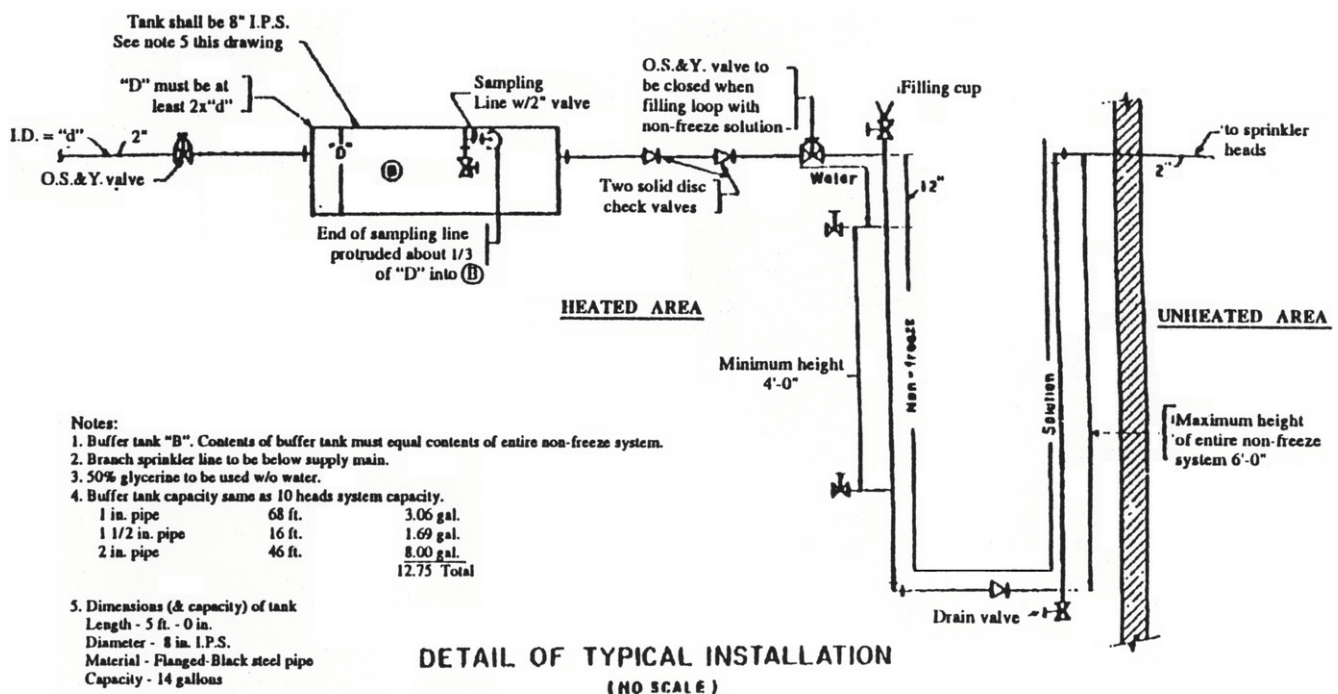

Figure 5-5.4 Arrangement of Supply Piping and Valves

Reference Standard 17

CHAPTER 6-Outside Sprinklers for Protection Against Exposure Fires

6-1 Water Supply and Control. Delete

6-2 System Components. Delete

CHAPTER 7-Hydraulically Designed Sprinkler Systems

7-1.1.2 Delete and substitute the following:

7-1.1.2 The design basis for such a system supersedes the rules in the sprinkler standard governing pipe schedules except that all systems continue to be limited by area, and pipe shall be not less than 1 inch nominal for ferrous piping and 3/4 inch nominal for copper tube and threadless copper pipe. The size of the pipe, number of sprinklers per branch line and number of branch lines per cross main are otherwise limited only by the available water supply.

However, sprinkler spacing and all other rules covered in this and other applicable standards shall be observed.

7-2.1 Delete and substitute the following:

Design criteria and calculations shall be submitted to the Commissioner along with the plans to obtain the necessary approval.

Table 7-4.3.1.4 Delete under column Pipe or Tube, "Plastic (listed)-All "and under C Value, Delete" 150"

CHAPTER 8-Pipe Schedule Systems

8-1 Delete and substitute the following:

The provisions of this Chapter shall apply to buildings of Class 1 construction, predominantly light hazard occupancy, and more than 100 feet high.

Add 8-1.2.1 Combined Systems Risers-Risers providing the water supply for both standpipe and sprinkler systems shall have a minimum diameter of 6-inches, however, a minimum diameter of 4-inches may be authorized in existing buildings if hydraulic calculations indicate that an adequate supply of water can be assured.

Add 8-1.2.2 When a combined riser is fed by a special service fire pump, a minimum diameter of 4-inches is required to feed fire hose stations. Riser size beyond last hose station is to be determined by hydraulic calculations.

Add 8-1.3.1 In buildings having mezzanine floors, large platforms, or large openings between floors which cannot be closed or satisfactorily cut off, the possibility that all or most of the sprinklers might be opened by a single fire should be considered in determining the size of risers. Where occupancy and construction are exceptionally good, and where there is a little likelihood of a fire spreading beyond the vicinity of its origin, the size of the feed main may be based on the total number of sprinklers in the main area plus half the number in the secondary area. A sprinkler water curtain may be considered an acceptable cut off for openings of less than 1000 square feet.

Add 8-1.4 Sizes for Domestic Water Piping. Where

permitted by the building code, 10 or less heads, that are connected to the domestic water system shall have the piping sized in accordance with the tables herein, and the domestic water line to which the sprinkler piping is connected shall be at least the size of the sprinkler line connected thereto. Connections may be made directly to cross-connections or headers.

8-3.2 Delete.

8-4.2 Add the following to the first sentence: "or as modified by Table 2-2.1B."

8-4.3 Delete.

8-4.4 Add the following:

8-4.4 Combined Systems. Risers providing the water supply for both standpipe and sprinkler systems shall have a minimum diameter of 6 inches: provided, however, a minimum diameter of 4 inches may be authorized in existing buildings if hydraulic calculations indicate that an adequate supply of water can be assured.

Chapter 10-Delete

Appendix A, B and C and D shall be considered part of this Reference Standard, subject to the following modifications:

A-1-7.2.1 Delete.

A-1-7.3.1 Delete.

A-1-7.3.2 Delete.

A-1-7.3.3 Delete.

A-1-7.4 Delete and substitute the following:

A-1-7.4 New installations protecting extra hazard occupancies may be hydraulically designed or pipe schedule systems may be utilized, provided that a sufficient volume of water is supplied, and the water pressure is adequate. When the pipe schedule is used hydraulic calculations shall be done to prove that adequate water volume and water pressure are available.

A-1-7.4.1 Delete.

A-1-8.1.2 Delete and substitute the following:

A-1-8.1.2 Used equipment shall not be permitted unless completely overhauled by the manufacturers; and shall be subject to the approval of the Commissioner.

A-1-9 Delete.

A-2-2.3.3 Delete.

A-2-6.3 Amend sub-section titled "Location of Pressure Tanks" to read as follows:

Pressure tanks shall be located at or above the top level of sprinklers.

A-2-7.1 Delete.

A-2-7.2 Delete.

A-2-7.3 Delete.

A-3-1.1.5 Delete.

A-3-3.2 Delete.

A-3-3.7 Delete.

A-3-7.4 Delete and substitute the following:

A-3-7.4 The fire hazard of the brazing and welding process should be suitably safeguarded. Fire guards having Certificates of Fitness from the Fire

Reference Standard 17

Department shall be provided as required, and portable fire fighting equipment shall be provided.

Add new sentence:

Self-cleaning fluxes shall not be used. Continued corrosive action after the soldering process is completed could result in leaks from the seats of sprinklers.

A-3-10.2 In second paragraph, delete the words "copper tube" and substitute "brass piping or equivalent."

A-3-12.4 Delete and substitute following:

A-3-12.4 The fire hazard of the brazing and welding process should be suitably safeguarded. Fire guards having Certificates of Fitness from the Fire Department shall be provided as required and portable fire fighting equipment shall be provided.

A-4-4.4.4 Add to end of first sentence:

Subject to the approval of the Commissioner.

A-5-3.3 Delete paragraph(b) and add:

(b) The dry-pipe valve should be adequately pressurized to conform to manufacturer's design and available water pressure.

B-4-2.4.6 Delete.

B-7 Delete.

Appendix C Referenced Publications Delete

* 310-90 BCR; 633-83 BCR

***REFERENCE STANDARD RS 17-2A STANDARD FOR THE INSTALLATION OF SPRINKLER SYSTEMS IN RESIDENTIAL OCCUPANCIES UP TO AND INCLUDING SIX STORIES IN HEIGHT**

ANSI/NFPA No. 13R-1994 - Standard for the Installation of Sprinkler Systems in Residential Occupancies up to and Including Four Stories in Height.

Modifications - The provisions of NFPA No. 13R-1994 shall be subject to the following modifications. The section and paragraph numbers are from that standard.

Preface

Change NFPA 72, *National Fire Alarm Code* to Section 27-979 of the Administrative Code.

Chapter 1 - General Information

Section 1-1 – Change four stories to six stories.

Section 1-3 – The definition of Multipurpose Piping shall be deleted.

Section 1-3 – The definition of Residential Occupancies shall be deleted. The definition of such use as stated in Title 27, Chapter 1, subchapter 3 of the Building Code shall be used.

Section 1-5.2 – Delete and substitute the following:
Section 1-5.2 - Other types of pipe or tube may be used, but only those investigated and listed for this service by a nationally recognized testing and inspection agency in accordance with Underwriters Laboratory Standard 1821

and 1887. The use of pipe or tube other than that described above must involve consideration of many factors, e.g.

(a) Pressure rating

(b) Beam strength (hangers)

(c) Corrosion (chemical and electrolytic)

(d) Resistance to failure when exposed to elevated temperatures

(e) Methods of joining (strength, permanence, fire hazard)

(f) Availability of fittings (for sprinkler outlets and proper routings.)

(g) Physical characteristics related to integrity during earthquakes

(h) Toxicity

(i) Combustibility

(j) Movement during sprinkler operation (water distribution).

Nonmetallic pipe and tube shall comply with the portions of the ASTM standards specified in Table 1-5.2 that apply to fire protection service in addition to the provisions of this paragraph. Nonmetallic pipe shall only be used in wet pipe systems. Nonmetallic pipe shall be installed in accordance with the manufacturer's installation instructions, and in accordance with rules promulgated by the Commissioner of Buildings.

Table 1-5.2 Delete Special Listed Polybutylene (PB) Pipe.

Section 1-5.6 - Delete and substitute the following:

Section 1-5.6 - Joints for the connection of copper tube or threadless pipe shall be brazed. Brazing filler metal classed BCuP-5, BAG-2 (ANSI/AWS A5.8-89) or other approved methods may be used. Lead free solder joints may be permitted for wet pipe systems when the temperature classification of the installed sprinklers is Ordinary or Intermediate.

Section 1-5.7 - Delete and substitute the following:

Section 1-5.7 - Other types of fittings may be used, but only those investigated and listed for this service by a nationally recognized testing and inspection agency in accordance with Underwriters Laboratory Standard 1821 and 1887. The use of fittings other than that described above must involve consideration of many factors as described in Section 1-5.2. Nonmetallic pipe and tube fittings shall comply with the portions of the ASTM standards specified in Table 1-5.7 that apply to fire protection service in addition to the provisions of this paragraph. Nonmetallic pipe and tube fittings shall only be used in wet pipe systems. Nonmetallic pipe and tube fittings shall be installed in accordance with the manufacturer's installation instructions, and in accordance with rules promulgated by the Commissioner of Buildings.

Section 1-6.2.1 - Change NFPA 13 to RS 17-2, and add the following: "The use of antifreeze solutions other than glycerine-water in sprinkler systems using plastic pipe shall not be permitted."

Chapter 2 - Working Plans, Design, Installation, Accepted Tests and Maintenance

Reference Standard 17

Section 2-1 - Delete

Section 2-1.1 - Delete

Section 2-1.1.1 - Delete

Section 2-1.1.2 - Delete

Section 2-1.2 - Delete

Section 2-1.2.1 - Delete

Figure 2-1.2.1 - Delete

Section 2-1.2.2 - Delete

Section 2-1.3 - Delete

Section 2-1.3.1 - Delete

Section 2-1.3.1.1 - Delete

Section 2-1.3.1.2 - Delete

Section 2-1.3.1.3 - Delete

Section 2-1.3.2 - Delete

Section 2-3.2 - Add subparagraph (e) as follows:

(e) A common supply main to the building, serving both sprinklers and domestic uses, may be used if provision is made to prevent flow on the domestic water system upon operation of sprinklers, and closure of the main sprinkler control valve, i.e., the house control valve, will shut off the domestic water supply.

Section 2-3.3 - Delete

Section 2-3.3.1 - Delete

Section 2-3.3.2 - Delete

Section 2-4.1.1 - Delete the "exception"

Renumber Sections 2-4.1.2 and 2-4.1.3 to be as follows:

Section 2-4.1.2 to be 2-4.1.3

Section 2-4.1.3 to be 2-4.1.4

Add new Section 2-4.1.2 to read as follows:

Section 2-4.1.2 - Except for the meter set controlling combined domestic water and fire sprinkler systems, sectional control valves and other valves if provided in supply pipes to sprinklers shall be locked open and supervised open by one of the following methods:

(a) Central station, proprietary or remote station signaling service, or

(b) Local signaling service that will cause the sounding of an audible signal at a constantly attended point.

Exception- Underground gate valves with roadway boxes need not be supervised.

Section 2-4.2 - Delete and substitute as follows:

Section 2-4.2 - Except in buildings classified in occupancy group J-1, at least one 3 in. (76 mm) single inlet fire department connection shall be provided and located in accordance with Section 27-940 of the Building Code. Buildings classified in occupancy group J-1 shall be provided with siamese connections in accordance with RS 17-2.

Section 2-6 - *Exception No. 1:* - Delete and substitute the following: *Sprinklers are not required in bathrooms, water closet compartments, general rooms and shower rooms.*

Section 2-6 - *Exception No. 2:* - Delete and substitute the following: *Sprinklers are not required in clothes closets, linen closets and pantries.*

Section 2-6 - At the end of the section add the

following:

Location of sprinklers installed in buildings classified in occupancy group J-1 shall be in accordance with the requirements of RS 17-2.

Section 2-7 - Delete and substitute the following:

Section 2-7 - The owner is responsible for the condition of a sprinkler system and shall properly maintain the sprinkler system in accordance with the Fire Department's rules and regulations.

Chapter 3 - Referenced Publications

Delete in its entirety.

Appendix A - Explanatory Material

A-1-1, first paragraph, - Change four to six.

A-1-5.2 - Delete

A-1-5.7 - Delete

A-2-1.3.2 - Delete

A-2-3.3.1 - Delete

Figure A-2-3.2(a), (b) and (c) Delete

Appendix B - Referenced Publications

Delete in its entirety.

NOTE: Subjects that are not covered under this reference standard shall be in accordance with Reference Standard 17-2.

**DOB 6-25-99*

*REFERENCE STANDARD RS 17-2B STANDARD FOR THE INSTALLATION OF SPRINKLER SYSTEMS IN ONE- AND TWO-FAMILY DWELLINGS AND MANUFACTURED HOMES

ANSI/NFPA No. 13D-1994 - Standard for the Installation of Sprinkler Systems in One-and Two-Family Dwellings and Manufactured Homes.

Modifications - The provisions of NFPA No. 13D-1994 shall be subject to the following modifications. The section and paragraph numbers are from that standard.

Preface

Change NFPA 72, *National Fire Alarm Code* to Section 27-979 of the Administrative Code.

Chapter 1 - General Information

Section 1-3 - Delete the definition of Multi-purpose Piping System.

Section 1-3 - Delete the definition of Pre-engineered System.

Section 1-5.2 - Revise the exception to read: Listing may be waived for tanks and pumps.

Section 1-5.3 - Delete

Section 1-5.4 - Delete and substitute with the following:

Section 1-5.4 - Testing of a system can be accomplished by pressurizing the system 50 pounds (3.5 bar) above the normal system operating pressure and checking visually for leakage at each joint or coupling.

Fire Department connections are not required for systems covered by this standard, but may be installed

Reference Standard 17

at the discretion of the owner. In these cases, hydrostatic tests in accordance with Reference Standard RS 17-2 are necessary.

Dry systems should also be tested by placing the system under 40 pounds (2.8 bar) air pressure. Any leak that results in a drop in system pressure greater than 2 psi (0.14 bar) in 24 hours should be corrected. Check for leaks using soapy water brushed on each joint or coupling. Leaks will be shown by the presence of bubbles. This test should be made prior to concealing of piping.

Chapter 2 – Water Supply

Section 2-2 – Add subparagraph (e) as follows:

(e) A common supply main to the building serving both sprinkler and domestic uses may be used if provision is made to prevent flow on the domestic water system upon operation of sprinklers, and closure of the main sprinkler control valve, i.e., house control valve, will shut off the domestic water supply.

Section 2-3 - Delete

Chapter 3 - System Components

Section 3-1.1 - Delete the exceptions.

Add new Section 3-1.5 to read as follows:

Section 3-1.5 - Except for the meter set controlling combined domestic water and fire sprinkler systems, sectional control valves and other valves if provided in supply pipes to sprinklers shall be locked open and supervised open by one of the following methods:

(a) Central station, proprietary or remote station signaling service, or

(b) Local signaling service that will cause the sounding of an audible signal.

Exception - Underground gate valves with roadway boxes need not be supervised.

Section 3-3.2 - Delete and substitute the following:

Section 3-3.2 - Other types of pipe or tubes may be used, but only those investigated and listed for this service by a nationally recognized testing and inspection agency in accordance with Underwriters Laboratory Standard 1821 and 1887. The use of pipe or tube other than that described above must involve consideration of many factors, e.g.,

(a) Pressure rating

(b) Beam strength (hangers)

(c) Corrosion (chemical and electrolytic)

(d) Resistance to failure when exposed to elevated temperatures

(e) Methods of joining (strength, permanence, fire hazard)

(f) Availability of fittings (for sprinkler outlets and proper routings)

(g) Physical characteristics related to integrity during earthquakes

(h) Toxicity

(i) Combustibility

(j) Movement during sprinkler operation (water distribution)

Nonmetallic pipe shall comply with the portions of the ASTM standards specified in Table 3-3.2 that apply to fire

protection service in addition to the provisions of this paragraph. Nonmetallic pipe shall only be used in wet pipe systems. Nonmetallic pipe shall be installed in accordance with the manufacturer's installation instructions, and in accordance with rules promulgated by the Commissioner of Buildings.

Table 3-3.2 - Delete Specification for Special Listed Polybutylene (PB) Pipe and ASTM D3309.

Section 3-3.6 - Delete and substitute the following:

Section 3-3.6 - Joints for the connection of copper tube or threadless pipe shall be brazed. Brazing filler metal classed BCuP-5, BAG-2 (ANSI/AWS A5.8-89) or other approved methods may be used. Lead free solder joints may be permitted for wet pipe systems when the temperature classification of the installed sprinklers is Ordinary or Intermediate.

Section 3-3.7 - Delete and substitute the following:

Section 3-3.7 - Other types of fittings may be used, but only those investigated and listed for this service by a nationally recognized testing and inspection agency in accordance with Underwriters Laboratory Standard 1821 and 1887. The use of fittings other than that described above must involve consideration of many factors as described in Section 3-3.2. Nonmetallic pipe fittings shall comply with the portions of the ASTM standards specified in Table 3-3.7 that apply to fire protection service in addition to the provisions of this paragraph. Nonmetallic pipe fittings shall only be used in wet pipe systems. Nonmetallic pipe fittings shall be installed in accordance with the manufacturer's installation instructions, and in accordance with rules promulgated by the Commissioner of Buildings.

Section 3-6 – In the *Exception*, change *NFPA 72, National Fire Alarm Code* to *Section 27-979 of the Administrative Code*.

Chapter 4 - System Design

Section 4-3.3.3.1 - Add "The use of antifreeze solutions other than glycerine-water in sprinkler systems using plastic pipe shall not be permitted."

Section 4-3.3.4 shall be modified to read as follows:

Section 4-3.3.4 - Arrangement of supply piping and valves. - All permitted antifreeze solutions shall be installed in accordance with RS 17-2.

Figure 4-3.3.4 - Delete and substitute with:

Figure 5-5.4 - "Detail of Typical Installation" of Reference Standard 17-2.

Section 4-4.1 - Exception No. 1 - Delete NFPA 13, Standard for the installation of sprinkler systems and revise to read "Reference Standard 17-2."

Section 4-4.2 - Revise to read as follows:

Section 4-4.2 - Minimum Pipe Size - Minimum pipe size including copper and any other acceptable piping shall be 3/4 in. (19 mm).

Section 4-4.3 - Delete the exception.

Reference Standard 17

Section 4-6 shall be modified to read as follows:
"Sprinklers shall be installed in all areas with the following exceptions:

Exception No. 1. Sprinklers are not required in attics not provided with floors.

Exception No. 2 Sprinklers are not required in clothes closets, linen closets and pantries.

Exception No. 3. Sprinklers are not required in bathrooms, water closet compartments, general toilet rooms and shower rooms.

Exception No. 4. Sprinklers are not required in garages, provided that at least one sprinkler head is located within 3 feet (914mm) of any communicating opening between the garage and the dwelling.

Exception No. 5. Sprinklers are not required in open attached porches, carports and similar structures."

Chapter 5 - Limited Area Dwellings

Delete in its entirety.

Chapter 6 - Referenced Publications

Delete in its entirety.

Appendix A - Explanatory Material

Section A-1-1 - Delete third sentence of first paragraph and revise second sentence to read:

"Residential portions of any other buildings shall be protected with residential sprinklers in accordance with the New York City Building Code."

Revise last paragraph to read "For protection of multiple dwellings, refer to the New York City Building Code."

Section A-1-2 – Delete

Section A-1-3 - Revise to read "System control valves shall be the indicating type and shall be approved/accepted type."

Section A-1.4 – Delete

Section A-1-5.4 – Delete

Section A-2.2 - Delete entire section including all related diagrams, except for the following:

"When a tank is used for both domestic and fire protection purposes, a low water alarm activated when the water level falls below 110 percent of the minimum quantity specified in Section 2-1 should be provided".

Section A-2.3 - Delete all related diagrams.

Section A-2.3(a) – Delete

Section A-3-3.1 – Delete

Section A-3-3.2 - Delete

Section A-3-3.7 – Delete

Section A-3-5.6.1 - Revise to read as follows:

Section A-3-5.6.1 - Decorative painting of residential sprinklers is not to be confused with the temperature identification colors as referenced in Reference Standard 17-2.

Section A-5-5 – Delete

Table A-1.2(a) and (b) – Delete

Appendix B - Referenced Publications

Delete in its entirety.

* *DOB 6-25-99*

**REFERENCE STANDARD RS 17-3

Standards for the Installation of Fire, Sprinkler, Standpipe, Smoke Detection, Oxygen, Nitrous Oxide, and other Alarm and Extinguishing Systems

*"Installation, source of energy, wiring and other requirements shall comply with the applicable provisions of Sections one through fourteen, inclusive; provided, however, that fire protection pre-signal systems for buildings in Occupancy Group G, of Construction Group 1-A (fireproof) may comply with the provisions, of Section 15 in lieu of sections 1 through 14, when such pre-signal systems are installed or existing systems are modified to provide fire alarm signal service under adverse malicious false alarm conditions, and when permitted by the Fire Commissioner."

**515-75 BCR*

1. A. SOURCES OF ELECTRICAL POWER

Two sources of electrical power shall be provided as follows:

(1) The primary source shall be generated electric power not exceeding 277/480 volts, supplied by utility company power, or isolated plant.

(2) The secondary source shall be an emergency power system (as per 27-396), emergency generator and/or battery power.

One source of power shall be connected to the system at all times. The primary and secondary power sources shall be so arranged and controlled by automatic transfer switches and/or circuitry that when the primary source of power fails, the secondary source will be connected automatically to the fire alarm signal system. Intermediary devices between the system supply and the source of power, other than fused disconnect switches, transformers, fused cutouts and automatic transfer switches, are prohibited. Such disconnect switches, cutouts, transformers and automatic transfer switches shall supply only the fire alarm system and other systems covered by this reference standard. When the utility company requires the installation of metering current transformers, the system supply shall be connected on the load side of the current transformers. All installations shall comply with the applicable sections of the New York City Electrical Code." The primary source of power and the secondary source (if emergency power system or generator) shall each be provided with a means of disconnect from the fire alarm system. For buildings supplied at 120/208 volts, each disconnect shall consist of a fused cutout panel, utilizing cartridge fuses, with provision for interrupting the unfused neutral and all ungrounded conductors. The neutral shall be provided with a removable solid copper bar. The incoming service neutral shall be bonded to the metallic housing of the cutout panel on the line side of the removable bar. The fused cutout panel housing shall

Reference Standard 17

consist of a locked metallic cabinet with hinged door, painted fire department red, and permanently identified as to the system served. For buildings served at 265/460 volts, the primary and secondary service disconnects shall be fused disconnect switches (in lieu of fused cutout panels) in locked, red painted, permanently identified enclosures. The service voltage shall be transformed to 120/208 volts and a fused cutout panel provided within 5 feet of the transformer on the 120/208-volt side. The incoming supply connections shall comply with the NYC Electrical Code, and the fused cutout panel shall comply with the requirements specified herein before.

B. PRIMARY POWER SOURCE

(1) The primary service to the fire alarm system shall be so arranged that the building source of supply can be disconnected without de-energizing the fire alarm supply. To accomplish this, the primary fire alarm supply shall be connected ahead of all building over current protection and/or switching devices.

(2) Partial systems such as strobe light control panels, partial fire alarm, automatic smoke/heat detection, and sprinkler alarm subsystems and/or other associated systems may be connected to an emergency supply riser panel via a tapped connection, and an identified, locked fused cutout box located within 5 feet of the tap.

Where an emergency power system (E.P.S.) is provided in accordance with section 27-396.4, it shall be connected to the emergency supply riser. Where an E.P.S. is not available, the emergency supply riser shall be connected to a tap ahead of the service switch.

C. SECONDARY POWER SOURCE

The secondary service to the fire alarm system shall be provided as follows:

(1) If the building has a required emergency power system, the secondary source shall be the emergency power system, regardless of whether the primary source is utility company power or an isolated plant.

(2) If the building has an emergency generator supplying power to any of the loads listed in 27-396.4, the secondary source shall be the generator.

(3) For all other buildings, the secondary source shall be a battery supply provided in accordance with Reference Standard 17-5 for storage batteries. The battery shall be designed for 24-hour supervisory operation of the system, followed by

(a) 6 hour total system load for systems with voice communication capability (A 45 minute period of voice/alarm operation at maximum connected load shall be considered equivalent to 6 hours of total system operation), or

(b) 15 minutes of total system load for systems without voice capability.

(4) Partial systems and/or associated systems may derive their secondary supply from batteries whether or not the

building is equipped with an emergency generator. Batteries shall be designed for 24-hour supervisory operation followed by 5 minutes of total system load.

All alterations to any existing approved fire alarm system involving or consisting of the replacement of the Fire Command Station, Fire Alarm Control Panel, Central Processing Unit, Floor Control Units, Remote Control Units, Data Gathering Panels, Terminal Transmission Board, and other similar or equivalent controls or control panels shall be required to comply with Section C(3) above. For systems in buildings which are in compliance with Sections C(1) or C(2) above, compliance with Section C(3) is optional.

2. Classification of Systems. - Systems shall be classified as follows:

(a) Manual interior fire alarm.
(b) Standpipe fire line telephone and signaling.
(c) Automatic heat, smoke, or products-of-combustion fire detecting and alarm, as follows:

- (1) Fixed temperature solder or bimetallic spot type heat detection.
- (2) Fixed temperature heat detecting wire.
- (3) Rate-of-rise pneumatic tube heat detection.
- (4) Photoelectric type smoke detection.
- (5) Products-of-combustion ionization detection.

(d) CO₂ extinguishing.
(e) Hood smothering and fan shutdown.
(f) Sprinkler alarm.
(g) Ventilation duct smoke and fire detection and fan shutdown.
(h) Oxygen and nitrous oxide alarm.
(i) Escalator fire door alarm.

Where fire alarm, sprinkler alarm, and/or automatic fire detection systems are installed in the same building, wiring interconnections shall be provided between the control boards of the Systems, and necessary actuating relays and transmitters shall be provided in the control boards, so that actuation of the sprinkler alarm and/or fire detection systems will activate the fire alarm system, and so that actuation of the fire alarm system will de-energize all fans, with the exception of those fans used for the Stair Pressurization System, controlled by the automatic detection system.

3. WIRING

A. Power Conductors (Above 75 volts) shall be:

(1) Copper: THHN, THWN/THHN, TFFN, TFN, FEP, RHH, RHW-2, XHH, or XHHW; minimum 600 volts; 90 C; for installation in rigid metallic conduit (RMC), intermediate metallic conduit (IMC) or electric metallic tubing (EMT).

(2) Cable type MI, M.E.A. approved for 2-hour fire resistance rating.

B. Low Voltage Conductors (75 volts and less) shall be:

Reference Standard 17

(1) Copper; THHN, THWN/THHN, TFFN, TFN, FEP, RHH, RHW-2, XHH, XHHW, minimum 600 volts; 90 C; for installation in rigid metallic conduit (RMC), intermediate metallic conduit (IMC) or electric metallic tubing (EMT)

(2) Minimum wire size No.18 AWG.

(3) Multiconductor cables run in raceways, or exposed as described hereinafter, shall meet the following additional requirements:

(a) Type FPLP only; minimum insulation thickness 15 mils; minimum temperature 150 C; colored red.

(b) Red colored jacket overall; minimum thickness 25 mils.

(c) Cable printing as per UL1424; must bear additional description "ALSO CLASSIFIED NYC CERT. FIRE ALARM CABLE" legible without removing jacket.

C. Installation of Conductors and Raceway shall be in accordance with the following:

(1) Power conductors shall not be installed in common raceways with low voltage conductors.

(2) Comply with applicable requirements of New York City Electrical Code, except where requirements are exceeded by this Reference Standard.

(3) Conductors other than M.I. cable shall be run in raceway, except as specifically described below.

(4) Multi-conductor cables may be installed without raceway protection where cable is protected by building construction. Where not protected by building construction, cables shall be located 8 feet or more above the finished floor and not subject to physical tampering or hazard. Locations within eight feet of the finished floor that are deemed as "protected by building construction" shall include raised floors, shafts, telephone and communication equipment rooms and closets, and rooms used exclusively for fire alarm system equipment. In any suppression and extinguishing system activated by automatic fire detection, including, but not limited to, pre-action sprinkler, deluge sprinkler, clean air agent, halon, range hood, CO₂ and dry chemical, multi-conductor cables shall be installed in RMC, IMC, or EMT.

(5) All wiring within mechanical and elevator equipment rooms shall be run in raceway.

(6) Raceways run within 8 feet of finished floor in garage areas, loading docks, mechanical rooms, and elsewhere where subject to mechanical damage, shall be rigid galvanized steel conduit only.

(7) Where wiring is required to be run in raceway, install conductors in rigid metallic conduit (RMC), intermediate metallic conduit (IMC) or electric metallic tubing (EMT), except that multi-conductor cables may also be run in surface metal raceway. Flexible metallic conduit, not exceeding 36" in length, shall be permitted for final connections to initiating and notification devices. Conductors for other electrical systems shall not be installed in raceways containing REFERENCE STANDARD 17 conductors.

(8) Where allowed to be run without raceway protection, multi-conductor cables shall be installed as follows:

(a) Cables shall not depend on ceiling media, pipes, ducts, conduits, or equipment for support. Support independently from the building structure.

(b) Secure by cable ties, straps or similar fittings, so designed and installed as not to damage the cable. Secure in place at intervals not exceeding 5'-0" on centers and within 12" of every associated cabinet, box or fitting.

(9) Installation of raceways, boxes and cabinets shall comply with the following general requirements.

(a) Covers of boxes and cabinets shall be painted red and permanently identified as to their use.

(b) Penetrations of fire-rated walls, floors or ceilings shall be fire stopped.

(c) Within stairways, raceways within 8 feet of the floor shall not be installed so as to reduce or obstruct the stairway radius.

(d) Raceways or cables shall not penetrate top of any equipment box or cabinet.

(10) All conduits supplying 120-volt power to the fire command station and/or fire alarm control unit and/or to outlying control cabinets, shall contain a green insulated grounding conductor sized in accordance with the New York City Electrical Code (#10 AWG minimum). The grounding conductor shall be connected to the ground bus or other suitable grounding terminal in each box and cabinet in which it enters. At the fuse cutout panel supplying the fire alarm system, provide a grounding electrode conductor sized and installed in accordance with the New York City Electrical Code (#10 AWG minimum).

(11) For cabinets whose 120-volt supply is not derived from the main fire alarm system cutout panel, provide green insulated separate grounding electrode conductors, sized and installed as per New York City Electrical Code (#10 AWG minimum). In steel-framed buildings, a connection to local steel structure will be acceptable.

(12) Splices and terminations of wires and cables shall be as follows:

(a) Permitted only in boxes or cabinets specifically approved for the purpose.

(b) Utilize mechanical connections specifically approved by U.L. 486 A & C for the conductors, or if soldered, first joined so as to be mechanically and electrically secure prior to soldering and insulating. Temperature rating of completed splices shall equal or exceed the temperature rating of the highest rated conductor.

(13) Wiring for audible and visual alarm notification devices shall be arranged so that a loss of a portion of the wiring on a floor will not render more than 60% of the devices of each type inoperative, and the devices shall be so connected to the circuitry (i.e., by means of alternate circuits) as to maintain at least partial audibility/visibility throughout the entire floor.

Reference Standard 17

4. Fire Alarm Sending Stations. -

*(a) In manual fire alarm signal systems, the metal case enclosing exposed or surface alarm boxes shall be of cast iron or cast No. 43 aluminum or approved aluminum-zinc alloy, and shall be drilled and tapped to receive the conduit. Where exposed to moisture, the box shall be closed in a weatherproof outer shell. In new buildings, approved galvanized sheet steel back-boxes embedded in the wall may be used and the conduits shall be secured by lock nuts and bushings.

**Local Law 16-1984*

(1) A floor warden station with a speaker mechanism having a fire resistant assembly and a manual fire alarm station may be installed in the same housing. A self-restoring push button that will silence an alarm speaker while being held in place, shall be required wherever such speaker is within 8 feet of a floor warden station.

(b) All current-carrying parts shall be insulated from parts carrying current of opposite polarity with approved insulating material.

(c) All coded pull-lever type stations shall be constructed with a door or other approved means to protect the pull lever against accidental injury. The wording "IN CASE OF FIRE - OPEN DOOR AND PULL DOWN LEVER" in raised letters, or equivalent instructions, shall appear on the door.

(d) In systems using break-glass or break-rod type stations, at least one extra glass rod or glass pane for each station in the system shall be kept in the building. Break-glass boxes shall have the glass rod or pane mounted on the surface of the station covers or mounted internally in such a manner that the glass must be broken to actuate the sending station, Suitable hammers on chains attached to the boxes, or other approved means of breaking the glass shall be provided.

(e) The box or station of a coded system shall be so designed that once started, the proper transmission of a complete set of signals cannot be interfered with by manipulation of its starting device.

(f) Each closed circuit coded box or station shall be arranged to send a definite code of signals to indicate the floor or portion of the floor on which it is located.

(g) Not less than 3, nor more than 20, taps or blasts shall be given at each revolution of the code wheel. The code wheel shall revolve at least four times for each operation of its starting device and shall be of metal properly insulated from ground.

(h) Boxes or stations used in systems in which whistles, vibrating bells, or horns are employed shall be so timed that the sounding devices will give the code signals clearly.

(i) Contact points shall be in multiple.

(j) Contact points and contacts of the testing devices shall be of silver or other approved material and of the scraping type. The contact points and contacts shall be secured in a substantial manner to springs of phosphor

bronze or other approved material, and shall be so designed as to positively break a circuit carrying 0.10 ampere at 250 volts under actual operating conditions.

(k) Lever boxes shall be so designed as to automatically wind when the lever is pulled for an alarm. Boxes requiring glass replacements shall be so arranged that replacement cannot be made without resetting the mechanism for another alarm.

(l) Where it becomes necessary to install more than one set of contacts operating from code wheel, approval must be obtained from the fire commissioner before the installation. This shall not include pre-signal features. The box shall have its code signal number plainly marked thereon.

(m) Uncoded boxes. -

(1) Uncoded closed circuit fire alarm stations may be operated by a break-glass or break-rod or a pull lever device so arranged that the alarm cannot be interfered with except by resetting or replacement of the glass or rod by an authorized person.

(2) The construction and materials shall be equivalent to that of the standard approved type coded closed circuit station, except that the contacts shall be of sufficient capacity to safely carry out the entire operating current of the gong circuit without excessive heating.

(n) Station testing devices. -

(1) Each fire alarm system shall be provided with an auxiliary device to test the signaling devices. The auxiliary device shall be located in one of the alarm boxes or mounted on the control board. Such testing device shall be arranged so that the test is made without operating the break wheel of the box or interfering with the dual operating feature.

(2) Provisions shall be made for a silent test of coded alarm box mechanisms without operating the signaling devices. Such test device shall be designed to prevent any person, except those in authority, from operating the same and to prevent the possibility of the box being left inoperative after the test.

5. Alarm Sounding Devices. -

*(a) Alarm sounding devices shall be sufficient in number to be clearly audible to all occupants of a building. Approved gongs shall be provided as the sounding devices. Where gongs or bells are not audible, approved horns or whistles may be provided. Chimes and other alarm sounding devices may be installed only with the approval of the commissioner.

(b) Gong shells shall be pinned to prevent turning and then securely fastened to their supports by a machine cap screw at least 3/8 in. in diameter.

(c) Gong shells shall be covered with a rust preventive. The gong support and gong frames shall be cast in one piece.

**Local Law 16-1984*

6. Fire Alarm System Control Boards. -

(a) Supervising circuit. -

Reference Standard 17

(1) A small current flow shall be maintained to constantly supervise each circuit. A millimeter, or other approved current indicator, shall be provided and connected so as to indicate the supervising current.

(2) The supervising circuit shall be provided with a trouble bell operating an open circuit and arranged to ring continuously in case of failure of the system. The trouble bell shall be so located that it will be within audible range of a responsible person in the building.

(3) Trouble bells may be fitted with silencing switches only when the switch is connected in such a manner that the act of silencing the bell by the operation of the switch automatically transfers the trouble signal to a red lamp on the control board. When the trouble has been repaired, the alarm bell shall ring until the silencing switch has been reset to operate under normal conditions.

(4) The trouble bell shall be of the vibrating type and shall give a distinctive signal.

(b) Protection of sending and sounding devices. -

(1) In fire alarm signal systems, moving parts of sending stations and sounding devices shall be enclosed in metal casings, made dust proof and damp proof when necessary, and clearly marked with instruction for use.

(2) Whenever necessary, hammer rods of gongs shall be suitably protected against mechanical damage by the use of a guard or equivalent means. If subject to possible mechanical damage, the entire device shall also be enclosed in a protecting case made of approved wire netting or perforated metal. All casings shall be insulated from current carrying parts, but shall be grounded to the conduit.

(c) Standards of electric alarm apparatus. -All electrically actuated apparatus used in fire alarm systems shall be so designed and constructed that it will operate satisfactorily at a current flow of 15 per cent above or below the normal operating current.

(d) Insulation. -

(1) Insulating materials used shall be varnished cambric, bakelite, mica, or equivalent insulating material.

(2) The use of fiber or paper as an insulating material for the fire alarm signal systems is prohibited.

(3) The insulating materials used shall be capable of withstanding an insulation breakdown test of 1,000 volts a.c. plus twice operating voltage applied for 1 minute.

(e) Electromagnets. -

(1) Electromagnet windings shall be impregnated with an insulating, moisture repelling compound of the silicone or epoxy type.

(2) Electromagnet coils used on alternating current, when composed of enameled wire, shall have an additional approved insulation on each wire. The coils may be of the form-wound type.

(3) A protective cover to prevent mechanical damage shall be provided over the entire coil.

(4) Electromagnetic coils shall be fastened to prevent floating.

(5) Electromagnet cores shall be of the best grade of ferrous material so as to reduce to a minimum the possibility of failure due to residual magnetism.

(6) Electromagnet cores for use on alternating current shall be of laminated construction or other approved method to prevent heating and promote efficiency.

(7) Electromagnet cores of relays and gongs shall be treated to prevent corrosion. Paint or varnish shall not be used for this purpose.

(8) Nonmagnetic freeze pins shall be used to prevent two magnetic surfaces from making physical contact with each other.

(f) Relays. -

(1) The armatures of all relays shall depend on gravity or magnetic attraction for their operation. However, armature operation may be initiated by flat-type springs when permitted by the commissioner. The use of spiral springs is prohibited.

(2) Adjustments shall be of such a character that they can be securely locked.

(3) Contact points shall be of sufficient area to carry the current used in operation and to insure long life. They shall be of pure silver or other approved material and properly riveted to their support. Contact arms shall be of phosphor bronze, and shall be of the dead beat type. Contact assemblies shall be of such a character that their operation is of a scraping self-cleaning nature. The use of condensers across contacts in order to absorb the arc in any part of a fire alarm circuit is prohibited.

(4) Relays shall be free from objectionable hum when used on alternating current.

(g) Time limit delay device. -

(1) All gong circuit shell and special signal apparatus may be protected by a time limit delay device. This time limit delay device shall consist of a heating coil so designed that the normal operating current will have little or no effect upon a thermostatic bimetallic bar or strip contained therein. Any abnormal increase over operating current or the continued cumulative heating effect thereof after a period of at least 3 minutes, but not more than 20 minutes, shall cause the thermostatic element to expand. The expansion of this element shall automatically open the source of current supply to the gongs or devices protected. The operation of the time limit delay device shall cause the trouble bell to ring.

(2) Time limit delay devices shall be so connected in the fire alarm circuit that their operation will not open the fire alarm box circuits.

(3) Where, due to the extent of the installation, it becomes necessary to install a number of time limit delay devices, the operation of a single time delay device shall not affect other sounding devices similarly protected.

(4) A contactor relay to operate the sounding devices shall be provided on all direct gong circuits exceeding two in number. Gong circuits not requiring contactor

Reference Standard 17

relays shall be operated by contacts properly phased for the armature of the box circuit relay.

(5) A separate time limit delay device, contactor supervisory relay and gong supervisory relay, shall be provided for each four gong circuits or fraction thereof.

(h) Switches. -Triple pole, double throw, broken back knife switches properly supervised, and connected to emergency resistors, shall be provided on all box and gong circuits when the circuits exceed three in number.

(i) Instruments. -A separate approved milliammeter, or other approved current indicator, shall be provided for the box circuit and each four gong circuits on the control board when the gong circuits exceed three in number. A separate milliammeter shall be provided to indicate the supervisory current of contactor relays and emergency switch circuits. This meter shall be known as the "board meter."

(j) Resistors. -

(1) Resistors shall be of the vitreous enameled type and shall be mounted on the front or face of control panels. Wire wound resistors, protected by a suitable metal guard, may be used when permitted by the commissioner. Ferrule or knife contact type resistors shall not be used.

(2) A protective resistor shall be placed in the negative, or live, lead of all box circuits to protect the contacts of the boxes in the event of a ground. This resistor shall have a resistance of at least 300 ohms, but no more than 750 ohms.

(3) All relays, current indicators, resistors, time limit delay devices, and other apparatus used in connection with the operation and supervision of closed circuit fire alarm signal systems shall be properly mounted on a panel of approved material in a metal cabinet provided with lock and key. The control board shall be located in a place where it will be subject to the least vibration and least chance of mechanical damage. The location shall be free from moisture, flammable gases, and dust. Furthermore, the control panel shall be located so that it can be kept under the frequent view of a responsible occupant of the building delegated by the owner to be in charge.

(4) Control board panels shall be of insulating material such as ebony asbestos, bakelite, or other approved materials at least 1/2 in. thick. Control boards mounted in each cabinet shall be securely fastened in each corner.

(5) Provision shall be made for sufficient wire gutter space around the panel. Gutter space shall be a minimum of 2 in. at sides, top, and bottom. Wire in gutter space shall be properly laced in a neat and workmanlike manner on all control boards.

(6) Conduit knockouts shall not be provided in the top of the control board cabinet.

(7) A wiring diagram of the alarm system approved by the commissioner and the approved card of instruction properly marked and securely fastened shall be provided within the control board cabinet. When it becomes

necessary to mount the diagram outside of the cabinet, the diagram shall be framed under glass or equivalent material.

(8) All control board cabinets shall be provided with sight holes and glass panels to make meters on the inside of the cabinets visible from the outside.

*(9) Control boards may be of the solid state circuitry type with modular construction and replacement components.

**Local Law 16-1984*

7. Painting of Equipment. -All enclosing cases for fire alarm, sprinkler alarm, smoke detection, and oxygen and nitrous oxide alarm apparatus shall be painted fire department red, except where approval is given by the commissioner to deviate from this requirement.

8. Closed Circuit Annunciators. -

(a) Annunciators used in connection with unit and general fire alarm systems shall be of an approved closed circuit type. The annunciator shall have approved types of relays equipped with a target shutter or other indicating device. The indicating device shall have marked thereon a description of the purpose it serves. The printed designation on unit or building annunciator's indicators shall be legible. The mechanism shall be so arranged that once operated the indicating device must be reset manually.

(b) A unit annunciator shall be so designed that the operation of any station in the unit causes a visible and audible signal. The unit annunciator shall be actuated by contact on a code wheel of the fire alarm station, or by contact on a relay connected to the fire alarm box circuit. In no case shall the station fire alarm circuit be used for this purpose.

(c) Trouble annunciators shall be so arranged that the indicating device will reset automatically when the cause of the trouble has been removed. The trouble annunciator shall be so designed that it will indicate visible and audible trouble signals in the event of trouble occurring on any circuit panelboard of unit annunciators. The trouble annunciator shall be actuated by the operation of contacts on all supervisory relays. Each relay of this annunciator shall be provided with two sets of contacts so arranged that one set will operate the 110-volt trouble signal, and the other set will actuate the register, if a register is used.

(d) A trouble buzzer switch lamp shall be mounted on the inside of each unit annunciator cabinet on the panel.

(e) A trouble bell, switch, and lamp shall be mounted on the inside of each trouble annunciator cabinet on the panel. Trouble bell may be placed at a distance from the annunciator by approval of the commissioner.

(f) Relay drops of annunciator shall be so designed that vibration from without or that caused by the trouble signal within will not operate the indicating devices.

(g) All annunciators shall be installed in a separate red enameled steel cabinet provided with an approved

Reference Standard 17

lock and key. Annunciators shall be marked in white letters at least 1 in. high with the words: "FIRE ALARM ANNUNCIATOR, ZONE" or "FIRE ALARM TROUBLE ANNUNCIATOR", whichever the case may be.

9. Automatic Heat and Smoke Fire Detection Systems. -

(a) **Classifications.** -Automatic heat and smoke fire detection systems shall be classified as follows:

(1) Fixed temperature solder or bimetallic spot-type heat detection.

(2) Fixed temperature heat detecting wire.

(3) Rate-of-rise pneumatic-tube heat detection.

(4) Photoelectric-type smoke detection.

(5) Products-of-combustion ionization detection.

(b) **Plans.** -Floor layouts shall show the automatic fire alarm signal equipment and its location, number of thermostatic heads, transmitters, control board, and sounding apparatus; also, all exits, partitions, and enclosures shall be identified on the layouts. The layouts shall be approved by the commissioner and the fire commissioner before work is started on the installation.

(c) **Wiring and electrical apparatus.** -

(1) All electrical wiring, signal apparatus, and thermostatic actuating devices shall be connected and operated on closed supervised electric circuits, and conform to the requirements for the installation of interior fire alarm systems.

(2) Approved automatic-type systems shall be installed under the supervision of the commissioner.

(3) When installed in connection with approved interior alarm systems, automatic systems shall have this connection made through an approved combination manual and automatic transmitter.

(4) When installed in connection with dry valves or other fire protective devices, automatic systems shall actuate the dry valve or devices through an approved magnetic trip.

(5) In automatically operated systems, each system shall have at least one manual fire alarm box as an auxiliary means for actuating the alarm system.

(6) Automatic systems shall be arranged to transmit a prescribed code signal as required by the fire commissioner.

(7) Closed circuit annunciators shall be provided in connection with automatic thermostatic systems when required by the fire commissioner.

(8) Transmitters, manual alarm boxes, testing boxes, and annunciators shall be so installed that a considerable jar cannot start their mechanism.

(9) Transmitters that require rewinding after operation shall be provided with a trouble bell to indicate a run-down condition.

(10) The trouble bell shall be arranged to give a distinctive signal different in tone from the trouble bell supervising the thermostatic alarm circuit.

(11) Each automatic thermostatic system shall have one or more combination manual and automatic transmitters located in a natural path of escape for each thermostatic

circuit, wherever the thermostatic alarm actuates the interior alarm system.

(12) All thermostatic devices shall operate on a closed supervised electric circuit.

(13) The thermostatic wiring may return to the control board and the end line resistor mounted thereon. This end line resistor may be in the form of a supervising relay.

(d) **Control boards.** -Thermostatic automatic systems shall be operated from properly supervised approved closed circuit control boards installed in a locked metal cabinet, which shall be painted fire department red and marked in 1 in. high white letters with the words "AUTOMATIC THERMOSTATIC FIRE ALARM".

(e) **Signal apparatus.** -Gongs, horns, or bells, shall be provided, where shown on plans in connection with each thermostatic alarm system, so that the signals will be clearly audible throughout the building or portion of the building requiring a fire alarm system. All thermostatic alarm systems shall be connected to an approved central office for transmission of an early alarm to the fire department.

**149-1975 BCR*

(f) **Testing.** -The thermostatic alarm system shall be so arranged that a periodic test of the entire system can be made by the person in charge of the building.

(g) **Thermostat installation.** -

(1) Thermostats shall be placed throughout the building, or portion of the building, including the inside of all closets, cellars, basements, lofts, and elevator wells, and under stairs as shown on approved plans.

(2) No portion of the building shall be exempt without written approval of the commissioner.

(3) Approval shall be obtained before the installation of high-temperature thermostats in boiler rooms, heating boxes, skylights, and other extra hazardous locations.

(4) The distribution of thermostatic heads and devices shall be in accordance with the requirements of reference standard RS 17-5 and as required herein.

(5) The distance from a wall or partition to a thermostat shall not exceed 1/2 the distance between thermostats in the same direction.

(6) A line of thermostats shall be run on each side of partitions.

(7) Spot thermostats of the solder type shall be arranged on smooth ceiling not more than 15 ft. apart, and at intervals of 15 ft. on each line.

(8) On irregular ceilings the thermostats shall follow the spacing as required in (7) above as near as possible, except that in no case shall the area protected by any signal head exceed 225 sq. ft.

(9) In ceilings on which there are bays, one or more heads shall be placed in each bay so the area protected does not exceed 225 sq. ft. for any head.

(10) Not more than 65 heads shall be installed on any supervised circuits.

Reference Standard 17

(11) A thermostatic circuit shall not serve or protect more than the area of any one floor or story, except by special permission.

(h) Fire detecting wire systems. -

(1) Thermostatic systems of the fire-detecting-wire type shall have the thermostatic wire so arranged and installed that there is minimum possibility of the wire being damaged.

(2) Where necessary, fire-detecting wire shall be protected against mechanical injury.

a. Each circuit shall consist of a continuous length of fire-detecting wire not exceeding 1,000 ft., and shall not protect an area greater than that of any one floor or story, except by special permission.

*b. Lines of fire detecting wire shall be so located throughout the area protected that they shall not be more than 15 feet apart and so that no point on the ceiling will be more than 7 1/2 feet from the nearest point of fire detecting wire, unless of a type approved for greater coverage.

**149-75 BCR*

c. Fire-detecting wire may be run either directly on ceilings or on side walls if the wire is placed not more than 20 in. below the ceiling, or on lower sides of timbers or projections.

d. Fire-detecting wire shall be securely fastened to its support in a manner that will not cause damage to the insulation or the outer braid.

e. Wiring, circuits, and all devices connected thereto shall comply in all respects with the requirements for manual fire alarms.

(i) Rate-of-rise pneumatic tube systems. -

(1) Thermostatic systems of the rate-of-rise pneumatic tube type shall have the pneumatic tubing so arranged and installed that the possibility of mechanical damage is minimized. Where necessary, copper tubing shall be protected against damage.

a. Each circuit shall consist of a continuous length of tubing not exceeding 1,000 ft. without branches or alternative paths.

b. Tubing shall be enclosed in conduit or otherwise insulated or legged in order to isolate signals.

c. In every enclosed space or separate room, there shall be at least 5 per cent of the total length of the exposed tubing or circuit.

d. In no case shall less than 25 ft. of exposed tubing be used in any enclosed space or separate room.

e. Lines of tubing shall be so disposed throughout the area to be protected that they will not be more than 30 ft. apart, and so that no point on the ceiling will be more than 15 ft. from the nearest point of tubing.

f. Tubing must be run either directly on ceilings, or on side walls if the tubing is placed not more than 20 in. below the ceiling, or on lower sides of timbers or projections.

g. In rooms where timbers or other projections form bays more than 1 ft. deep and 8 ft. wide between beam centers, at least one line of tubing must be run in each bay.

h. Wiring circuits and all devices connected thereto shall comply in all respects with the requirements for the manual fire alarms.

i. The service connection for an automatic thermostatic alarm system shall be taken at the street side of the service switch in a manner approved by the commissioner.

(j) Unusual construction. -Approval of the fire commissioner shall be required to install thermostatic devices under floors or roofs of removable-panel construction.

(k) Existing installations. -Thermostatic alarm systems previously installed and approved by the fire commissioner shall be accepted as long as they are maintained in good working order, and there is not a change in building height or construction. Where alterations interfere with the proper distribution of thermostatic heads, additional heads shall be installed.

(l) Photoelectric smoke detection systems. -These systems shall be installed in accordance with the requirements of reference standard RS 17-5. The requirements of the building code affecting the design and operation of smoke detecting systems in duct systems, shall apply.

(m) Products-of-combustion-type ionization detection systems. -These systems shall be installed in accordance with Underwriters' Laboratory requirements.

(n) Unusual construction. -Approval of the fire commissioner shall be required to install thermostatic, photoelectric, or ionization type detection devices under floors or roofs of removable panel construction.

10. CO2 Extinguishing Systems. -Carbon dioxide extinguishing systems shall be installed in accordance with Underwriters' Laboratory requirements.

11. Hood Smothering and Fan Shutdown Systems. -

(a) General. -The requirements of the building code affecting the design and operation of automatic fire extinguishing systems for installation in hoods and ducts that exhaust fumes from commercial cooking equipment, shall apply.

(b) Source of power. -A local source of electric power for the system shall be utilized. Control wiring shall be of the "fail safe" type so that loss of control power will shut off all equipment.

(c) Test switch. -A test switch shall be provided, and wired so as to permit testing of the control wiring against shorts or open-circuits without actuation of the smothering system.

(d) Alarm sounding device. -A local alarm gong shall be provided, and shall sound upon actuation of the smothering system.

Reference Standard 17

12. Central Oxygen and Nitrous Oxide Alarm Systems. - A closed circuit electrical alarm system shall be provided to give visible and audible signals when the pressure in the system varies 8 lbs. above or below the normal line pressure of 50 lbs. Alarm indicating panels shall be so located in the hospital that they are under 24 hr. observation by a responsible person, or persons, delegated by the owner. Additional indicating panels may be provided in other locations subject to the approval of the fire commissioner.

****13. Licensed Contractors.** -Only a person holding a license, or a special license in accordance with the provisions of the New York City electrical code, shall install, alter or repair electrical wiring or apparatus for fire alarm systems in any building. Upon approval by the commissioner, a manufacturer's designated representative may alter or repair a specific fire alarm system.

14. Used or Rebuilt Apparatus. -Used apparatus shall not be reused for any interior fire alarm system until the same has been reconditioned in the shop of an approved manufacturer of interior fire alarm apparatus. Approval shall be obtained from the commissioner prior to installation. The use of reconditioned apparatus whose manufacturer has discontinued manufacturing equipment is prohibited.

***Local Law 16-1984*

***15. Fire Protective Pre-Signal Systems for Class "G" Assembly and Educational Occupancy Buildings in Group 1-A (Fireproof) Construction**

**515-75 BCR*

I - SCOPE

When permitted by the Fire Commissioner, new fire signal system characteristics for pre-signal operation and existing manual coded and non-coded fire station signal modifications for pre-signal operation, shall be in accordance with the following schedule in its entirety and in accordance with Reference Standards RS 17-3, RS 17-3A, RS 17-3B and other applicable standards and permitted only in Class "G" educational occupancy buildings of Group 1-A fireproof construction. Interior alarm systems installed or altered in accordance with this standard shall be designated as "Class G Systems".

II - FUNCTION SCHEDULE

A. Introduction of a time delay between the operation of a coded, master coded or non-coded manual interior fire alarm station and the audible evacuation signal shall be limited to an adjustable interval of 0-180 seconds. The specific duration of the time delay shall be determined by the Fire Commissioner for each specific premises where permitted. The time delay, when instituted by a manual station, shall also be effective for fan shutdown and other auxiliary equipment. There shall be no delay on automatic detection.

B. Alphanumeric annunciation of each manual and each automatic initiation for registration of the location of the device producing the alarm with response instructions determined and authorized by the Fire Commissioner. The registration shall indicate in seconds the delay time remaining for the last signal initiation and shall be visible to and in the immediate vicinity of the Chief Building Administrator's office.

C. Means for cancellation of a manual signal initiation within its introduced time delay accessible only to the Chief Building Administrator. Cancellation shall not be possible for fifty (50%) percent of the delay time expiration.

D. Means for by-passing the introduced time delay after a manual device initiation to produce the evacuation sounding and after normal school hours. The means shall be in the immediate vicinities of the Chief Building Administrator's office and the Building Engineer's office.

E. Master coding for the evacuation signal, providing for single stroke gong systems an evacuation signal comprising four rounds of three single stroke gong soundings only, or providing for dedicated loud speaker systems an evacuation signal comprising a rising tone of three seconds duration starting at a frequency of 400 hertz and ending with a frequency of 1000 hertz, repeated twelve times.

F. Automatic notification to the Fire Department via a class 3 manual station located in the vicinity of the Principal Administrator's office.

III - EQUIPMENT REQUIREMENTS

A. The acceptable means to provide the previously defined characteristics and modifications may include digital electronic circuitry with logic in accordance with the reference standard and as approved and with information interchange in accordance with the reference as approved. Where digital electronic circuitry is used, reliability rates shall be equal to or greater than the equivalent reliability rates for the relay circuitry that may be designed for this purpose. The acceptable means shall be uniform for a given installation. Where digital electronic circuitry is chosen as the acceptable means for a given installation the entire circuitry for this installation shall be digital electronic without exception.

B. The digital electronic alphanumeric annunciation may take one of the following three forms:

1. A fixed lettered display with characters a minimum height of one quarter inch, resulting from the conversion of a manual or automatic device initiation to a unique point.

2. A dot matrix display of a duration at least equal to the duration of the systems interrupt mode and originating in the manner of the fixed lettered display. The matrix shall be a minimum of seven by five dots per character.

3. A cathode ray tube display of duration in the manner of the dot matrix display and origination in the manner of the fixed lettered display. The minimum character height shall be one quarter inch.

Reference Standard 17

In addition the following form shall be provided in conjunction with one of the foregoing:

A teletypewriter is to receive only mode with origination in the matter of the fixed lettered display.

C. Other digital electronic alphanumeric annunciation devices such as liquid crystals or light emitting diodes or the like may be installed for this purpose in lieu of one of the above three forms when approved for use and acceptable to the Fire Commissioner.

D. All system events shall be recorded in hard copy along with the date and time of each particular event. These events shall include the following:

1. The manual or automatic device initiation.
2. The elapsed time in seconds from the manual or automatic initiation to the cancellation or the by-pass as above defined.
3. The elapsed time in seconds from the manual or automatic initiation to the evacuation sounding as above defined.

**E. Where a loud speaker system is used for the evacuation sounding, its amplifiers shall be designed for one hundred and fifty (150%) percent of rated load with a minimum of two discrete amplifiers. The loud speaker system may be used for voice communication, provided the evacuation signal use has priority. Speakers used for fire alarm systems shall be rated for 400 degrees F. and approved by the Board of Standards and Appeals. These speakers and amplifier requirements apply to all systems installed under any and all provisions of this code.

****Local Law 16-1984**

F. All fire protective pre-signal systems shall be operated daily when the building is occupied and a log shall be kept of such operation, accessible to the Commissioner. The hard copy of system events may be considered the required log. All equipment must be approved by Board of Standards and Appeals and acceptable to the Commissioners of Buildings and Fire Department, prior to installation.

IV - DETAILED STANDARDS FOR THE INSTALLATION OF CLASS "G" FIRE SIGNAL SYSTEMS

A. SOURCES OF ELECTRICAL POWER

Two sources of electrical power shall be provided as follows:

- (1) The primary source shall be generated electric power not exceeding 277/480 volts, supplied by utility company power, or isolated plant.
- (2) The secondary source shall be an emergency power system (as per 27-396), emergency generator and/or battery power.

One source of power shall be connected to the system at all times. The primary and secondary power sources shall be so arranged and controlled by automatic transfer switches and/or circuitry that when the primary source of power fails, the secondary source will be connected automatically to the fire alarm signal system. Intermediary devices between the system supply and the source of power, other than fused disconnect switches,

transformers, fused cutouts and automatic transfer switches, are prohibited. Such disconnect switches, cutouts, transformers and automatic transfer switches shall supply only the fire alarm system and other systems covered by this reference standard. When the utility company requires the installation of metering current transformers, the system supply shall be connected on the load side of the current transformers. All installations shall comply with the applicable sections of the New York City Electrical Code. The primary source of power and the secondary source (if emergency power system or generator) shall each be provided with a means of disconnect from the fire alarm system. For buildings supplied at 120/208 volts, each disconnect shall consist of a fused cutout panel, utilizing cartridge fuses, with provision for interrupting the unfused neutral and all ungrounded conductors. The neutral shall be provided with a removable solid copper bar. The incoming service neutral shall be bonded to the metallic housing of the cutout panel on the line side of the removable bar. The fused cutout panel housing shall consist of a locked metallic cabinet with hinged door, painted fire department red, and permanently identified as to the system served. For buildings served at 265/460 volts, the primary and secondary service disconnects shall be fused disconnect switches (in lieu of fused cutout panels) in locked, red painted, permanently identified enclosures. The service voltage shall be transformed to 120/208 volts and a fused cutout panel provided within 5 feet of the transformer on the 120/208-volt side. The incoming supply connections shall comply with the NYC Electrical Code, and the fused cutout panel shall comply with the requirements specified herein before.

B. PRIMARY POWER SOURCE

(1) The primary service to the fire alarm system shall be so arranged that the building source of supply can be disconnected without de-energizing the fire alarm supply. To accomplish this, the primary fire alarm supply shall be connected ahead of all building over current protection and/or switching devices.

(2) Partial systems such as strobe light control panels, partial fire alarm, automatic smoke/heat detection, and sprinkler alarm subsystems and/or other associated systems may be connected to an emergency supply riser panel via a tapped connection, and an identified, locked fused cutout box located within 5 feet of the tap.

Where an emergency power system (E.P.S.) is provided in accordance with section 27-396.4, it shall be connected to the emergency supply riser. Where an E.P.S. is not available, the emergency supply riser shall be connected to a tap ahead of the service switch.

C. SECONDARY POWER SOURCE

The secondary service to the fire alarm system shall be provided as follows:

(1) If the building has a required emergency power system, the secondary source shall be the emergency

Reference Standard 17

power system, regardless of whether the primary source is utility company power or an isolated plant.

(2) If the building has an emergency generator supplying power to any of the loads listed in 27-396.4, the secondary source shall be the generator.

(3) For all other buildings, the secondary source shall be a battery supply provided in accordance with Reference Standard 17-5 for primary batteries. The battery shall be designed for 24-hour supervisory operation of the system, followed by

(a) 6 hour total system load for systems with voice communication capability (A 45 minute period of voice/alarm operation at maximum connected load shall be considered equivalent to 6 hours of total system operation), or

(b) 15 minutes of total system load for systems without voice capability.

(4) Partial systems and/or associated systems may derive their secondary supply from batteries whether or not the building is equipped with an emergency generator. Batteries shall be designed for 24-hour supervisory operation followed by 5 minutes of total system load.

All alterations to any existing approved fire alarm system involving or consisting of the replacement of the Fire Command Station, Fire Alarm Control Panel, Central Processing Unit, Floor Control Units, Remote Control Units, Data Gathering Panels, Terminal Transmission Board, and other similar or equivalent controls or control panels shall be required to comply with Section (C3) above. For systems in buildings which are in compliance with Sections (C)1 or (C2) above, compliance with Section (C3) is optional.

D. ASSOCIATED SYSTEMS

Associated systems listed below shall have their actuation added to the Fire Control Panel:

1. Smoke detection systems.
2. Sprinkler water flow alarms.
3. Thermostatic alarms.
4. Fan shut down for HVAC and automatic smoke exhausters.
5. Stage fire control and deluge systems.
6. Other approved systems.

NOTE: The associated systems listed above shall all be interconnected with the Class "G" fire signal systems and shall have their alarm and common trouble signals indicated at the main control board.

E. WIRING

(1) Power Conductors (Above 75 volts) shall be:

(a) Copper: THHN, THWN/THHN, TFFN, TFN, FEP, RHH, RHW-2, XHH, or XHHW; minimum 600 volts; 90 C; for installation in rigid metallic conduit (RMC), intermediate metallic conduit (IMC) or electric metallic tubing (EMT).

(b) Cable type MI, M.E.A. approved for 2-hour fire resistance rating.

(2) Low Voltage Conductors (75 volts and less) shall be:

(a) Copper; THHN, THWN/THHN, TFFN, TFN, FEP, RHH, RHW-2, XHH, XHHW, minimum 600 volts; 90 C; for installation in rigid metallic conduit (RMC), intermediate metallic conduit (IMC) or electric metallic tubing (EMT)

(b) Minimum wire size No.18 AWG.

(c) Multiconductor cables run in raceways, or exposed as described hereinafter, shall meet the following additional requirements:

- Type FPLP only; minimum insulation thickness 15 mils; minimum temperature 150 C; colored red.

- Red colored jacket overall; minimum thickness 25 mils.

- Cable printing as per UL1424; must bear additional description "ALSO CLASSIFIED NYC CERT. FIRE ALARM CABLE" legible without removing jacket.

(3) Installation of Conductors and Raceway shall be in accordance with the following:

(a) Power conductors shall not be installed in common raceways with low voltage conductors.

(b) Comply with applicable requirements of New York City Electrical Code, except where requirements are exceeded by this Reference Standard.

(c) Conductors other than M.I. cable shall be run in raceway, except as specifically described below.

(d) Multi-conductor cables may be installed without raceway protection where cable is protected by building construction. Where not protected by building construction, cables shall be located 8 feet or more above the finished floor and not subject to physical tampering or hazard. Locations within eight feet of the finished floor that are deemed as "protected by building construction" shall include raised floors, shafts, telephone and communication equipment rooms and closets, and rooms used exclusively for fire alarm system equipment. In any suppression and extinguishing system activated by automatic fire detection, including, but not limited to, pre-action sprinkler, deluge sprinkler, clean air agent, halon, range hood, CO₂ and dry chemical, multi-conductor cables shall be installed in RMC, IMC, or EMT.

(e) All wiring within mechanical and elevator equipment rooms shall be run in raceway.

(f) Raceways run within 8 feet of finished floor in garage areas, loading docks, mechanical rooms, and elsewhere where subject to mechanical damage, shall be rigid galvanized steel conduit only.

(g) Where wiring is required to be run in raceway, install conductors in rigid metallic conduit (RMC), intermediate metallic conduit (IMC) or electric metallic tubing (EMT), except that multi-conductor cables may also be run in surface metal raceway. Flexible metallic conduit, not exceeding 36" in length, shall be permitted for final connections to initiating and notification devices. Conductors for other electrical systems shall not be installed in raceways containing REFERENCE STANDARD 17 conductors.

Reference Standard 17

(h) Where allowed to be run without raceway protection, multi-conductor cables shall be installed as follows:

- Cables shall not depend on ceiling media, pipes, ducts, conduits, or equipment for support. Support independently from the building structure.
- Secure by cable ties, straps or similar fittings, so designed and installed as not to damage the cable. Secure in place at intervals not exceeding 5'-0" on centers and within 12" of every associated cabinet, box or fitting.

(i) Installation of raceways, boxes and cabinets shall comply with the following general requirements.

- Covers of boxes and cabinets shall be painted red and permanently identified as to their use.
- Penetrations of fire-rated walls, floors or ceilings shall be fire stopped.
- Within stairways, raceways within 8 feet of the floor shall not be installed so as to reduce or obstruct the stairway radius.
- Raceways or cables shall not penetrate top of any equipment box or cabinet.

(j) All conduits supplying 120-volt power to the fire command station and/or fire alarm control unit and/or to outlying control cabinets, shall contain a green insulated grounding conductor sized in accordance with the New York City Electrical Code (#10 AWG minimum). The grounding conductor shall be connected to the ground bus or other suitable grounding terminal in each box and cabinet in which it enters. At the fuse cutout panel supplying the fire alarm system, provide a grounding electrode conductor sized and installed in accordance with the New York City Electrical Code (#10 AWG minimum).

(k) For cabinets whose 120-volt supply is not derived from the main fire alarm system cutout panel, provide green insulated separate grounding electrode conductors, sized and installed as per New York City Electrical Code (#10 AWG minimum). In steel-framed buildings, a connection to local steel structure will be acceptable.

(l) Splices and terminations of wires and cables shall be as follows:

- Permitted only in boxes or cabinets specifically approved for the purpose.
- Utilize mechanical connections specifically approved by U.L. 486 A & C for the conductors, or if soldered, first joined so as to be mechanically and electrically secure prior to soldering and insulating. Temperature rating of completed splices shall equal or exceed the temperature rating of the highest rated conductor.

(m) Wiring for audible and visual alarm notification devices shall be arranged so that a loss of a portion of the wiring on a floor will not render more than 60% of the devices of each type inoperative, and the devices shall be so connected to the circuitry (i.e., by means of

alternate circuits) as to maintain at least partial audibility/visibility throughout the entire floor.

F. FIRE SIGNAL SENDING STATIONS, CLASS "G" NON-CODED MANUAL STATION AND THE FIRE SIGNAL CONTROL STATION

1. There shall be at least one (1) fire signal sending station in each story of a building located in each path of escape. Additional stations shall be installed so that no point on any floor shall be more than two hundred feet from the nearest station.

2. Doors of sending stations shall be painted Fire Department "red," and lettered: "Fire Emergency - Open Door to Operate", or words to that effect. The instructions for operating the station shall be prominently displayed on an instruction card or, the lever of the station.

3. All current carrying parts shall be insulated from parts carrying current of opposite polarity with approved insulating material.

4. All pull lever type stations shall be constructed with an outer door and means to protect the pull lever against accidental operations. The wording: "In Case of Fire, Open Door and Pull Down Lever", in raised letters or the equivalent instructions, shall appear on the door.

5. For systems using break-glass or break-rod type stations, at least one extra glass pane or glass rod for each station in the system shall be kept in the building. Break glass stations shall have the glass rod or pane mounted on the surface of the station covers or, mounted internally in such a manner that the glass must be broken to actuate the sending station. Suitable hammers on chains attached to the stations, or other approved means for breaking the glass, shall be provided. Stations accomplishing the "break glass" principle using other approved means shall not be required to provide hammers or spare glass.

6. Non-Coded Stations

a. Non-Coded closed circuit fire signal stations shall be operated by a break-glass or break-rod or pull lever device so arranged that the signal cannot be interfered with except by resetting or replacement of the glass or rod by an authorized person.

b. The construction and materials shall be equivalent to that of the standard approved type coded closed circuit station described in Reference Standard RS 17-3, except that the contacts shall be of sufficient capacity to safely carry the entire operating current of the signal circuit without excessive heating.

7. Stations Testing Devices. Provisions shall be made for a silent test of sending station mechanisms without operating the signalling devices. Such test device shall be designed to prevent any person, except those in authority, from operating the test device and to prevent the possibility of the box being left inoperative after the test.

8. Provisions shall be made to supply an audible as well as visual signal at the fire signal control station from the fire signal station.

Reference Standard 17

G. EVACUATION SOUNDING DEVICES

1. Approved single stroke gongs or dedicated loud speakers shall be provided as the sounding devices. Approved loud speakers shall have heat resistant driven elements and shall conform to Reference Standard RS-17-5. When recessed loud speakers are used, they shall conform to the performance requirements of Reference Standard RS-17-5. The loud speakers, when mounted on walls, shall be mounted upon interior walls in preference to building core walls.

2. Recessed loud speakers, if used, shall be located not more than ten feet from the entrance to each required exit to insure proper evacuation signal reproduction. This spacing is based upon normal eight feet to ten feet ceiling height. Surface mounted loud speakers shall be mounted within ten feet of each egress to insure proper evacuation signal reproduction. For unusual conditions and higher ceilings, the loud speakers shall not be mounted more than twenty feet above the floor.

3. For new fire protective signal systems only, in the entire building when at least twenty-five (25%) percent of the occupants have hearing impairments and in those areas where the ambient noise level exceeds ninety decibels (90 dBA) on the "A" scale, provided in all applicable areas at least one visual evacuation signal. This signal shall be a xenon lamp flasher having a minimum flash intensity of one million candlepower, dissipating for each lamp flash a minimum energy of fifteen joules, and shall be wall mounted at a minimum height of nine feet above the floor. The lamp flasher shall be totally enclosed so that all visible and ultraviolet radiations at or below its center line shall be blocked and so that all visible upward radiation, shall be transmitted. The visual evacuation signal shall flash once every three seconds, repeated twelve times.

4. The evacuation sounding devices may be utilized for other audible purposes, including building security, when means is provided to insure fire evacuation signal priority.

H. FIRE SIGNAL SYSTEM CONTROL STATION

1. Supervising Circuits

a. Class "G" fire protective signal systems shall be supervised, except for the alphanumeric annunciator.

b. The supervising circuit shall be provided with a trouble signal arranged to sound continuously in case of failure of the primary power source or other derangements. The trouble signal shall be so located that it will be within audible range of a responsible person in the building.

c. Trouble signals may be fitted with silencing switches only when the switch is connected in such a manner that the act of silencing the signal by the operation of the switch will automatically transfer the trouble signal to a red lamp on the fire signal control station. When the trouble has been repaired, the alarm signal shall sound until the silencing switch has been reset to operate under normal conditions.

d. The trouble signal shall give a distinctive tone.

2. Protection of Sending and Sounding Devices. In fire protective signal systems, the sending stations and sounding devices shall be enclosed in metal casings, made dust proof and damp proof when necessary, and shall be clearly marked with instructions for use.

3. Standards of Electrical Signal Apparatus. All electricity actuated apparatus used in fire protective signal systems shall be so designed and constructed that it will operate satisfactorily at an input voltage level of twenty (20%) percent below or ten (10%) percent above the normal rated voltage.

4. Insulation

a. Insulating materials used shall be varnished cambric, bakelite, mica or other equivalent insulating material.

b. The use of fiber or paper as an insulating material is prohibited.

c. The insulating materials used shall be capable of withstanding an insulation breakdown test of one thousand volts ac., plus twice the operating voltage applied for one minute.

5. Electromagnets

a. Electromagnetic windings shall be impregnated with an insulating and moisture repelling compound of the silicone or epoxy type.

b. Electromagnetic coils used on alternating current, when composed of enameled wire, shall have additional approved insulation on each wire. The coils may be of the form wound type.

c. A protective cover to prevent mechanical damage shall be provided over the entire coil.

d. Electromagnetic coils shall be fastened to prevent floating.

e. Electromagnetic cores shall be of the best grade of ferrous material so as to reduce to a minimum the possibility of failure due to residual magnetism.

f. Electromagnetic cores for use on alternating current shall be of laminated construction or other approved method to prevent heating and to promote efficiency.

g. Electromagnetic cores of relays shall be treated to prevent corrosion. Paint or varnish shall not be used for this purpose.

h. Nonmagnetic freeze pins shall be used to prevent two magnetic surfaces from making physical contact with each other.

6. Wiring

a. All connections shall be secure and properly protected and, where subject to motion, shall be of approved flexible wire. All wiring of the fire signal control station, the fire station circuits and the supervisory circuits, shall be approved.

b. Binding posts, when used, shall be of such design that the wire is held between two flat surfaces. Binding posts shall be mounted on an approved terminal block or insulating strip. The spaces between the binding posts shall be at least one half inch, unless they are separated by approved barriers.

Reference Standard 17

c. Digital electronic printed circuit cards, when used, shall be one sixteenth inch thick glass fiber epoxy resin. The cards shall have color coded ejectors used to group cards according to function so that they may be located quickly and shall have plated through holes as feed through on all logic cards. The connection fingers shall be gold, plated over nickel.

7. Overload Protective Devices. The digital electronic circuits shall provide protection of all equipment and circuits by opening up the circuit to the equipment or devices protected. The operation of this overload circuit shall cause the trouble signal to sound at the fire signal control station.

8. The control boards shall operate so that trouble in an individual zone may be shunted out without affecting the operation of the rest of the zones of the system.

9. Provision shall be made for sufficient wire gutter space around the panel. The gutter space shall be a minimum of two inches at the sides, the top and the bottom. The wire in the gutter space shall be properly laced in a neat and workmanlike manner on all control boards.

10. Conduit knockouts shall not be provided in the top of the control board cabinet, unless designed and approved for entry on top.

11. A wiring diagram of the fire protective signal system approved by the Fire Commissioner and the approved card of instruction properly marked, shall be provided and securely fastened within the control board cabinet and at the fire signal control station. When it becomes necessary to mount the diagram outside of the cabinet, the diagram shall be framed under glass or an equivalent material.

12. Control Boards

a. The control boards and amplifiers used for voice communication and alarm shall be located in a safe, moisture and dust free location secure from unauthorized tampering. Otherwise a ventilated cabinet provided with a lock and a key suitably identified, shall be provided.

b. The amplifiers for the Class "G" systems shall have the capacity to deliver sufficient power to operate all evacuation sounding devices and the voice communication systems, and have a fifty (50%) percent reserve power capacity. In addition, the amplifiers shall be wired in such a manner that the imminent failure or actual failure of amplifiers shall shut down the amplifiers and shall indicate a trouble condition. The removal of an amplifier shall be indicated by a trouble signal at the fire signal control station. The opening of the control cabinets shall be supervised by a tamper switch producing a manually resetting trouble alarm at the fire signal control station.

13. Fire Control Station. The Station shall consist of the following equipment:

a. Time delay means in accordance with Section II A. above. At the end of the time delay or, at the time of the by pass, the interior evacuation signal shall sound and all interconnected controls shall operate.

b. Alphanumeric annunciation in accordance with Section II B. above.

c. A key controlled signal cancellation in accordance with Section II C. above.

d. A by-pass means in accordance with Section II D. above.

e. A printer which records system events in accordance with the Equipment Requirements of this standard, located in the Building Engineer's office.

f. Five day week digital electronic clocks to revert the pre-signal operation to normal (zero time delay) operation after normal building hours, and permitting immediate evacuation sounding after signal initiation determined by matching two successive code rounds.

I. PAINTING OF EQUIPMENT

All enclosing cases for fire signal, sprinkler alarm detection and associated systems alarm apparatus shall be painted Fire Department "red", except where approval is given by the Commissioner to deviate from this requirement.

J. INFORMATION DISPLAY SYSTEMS

1. The indicating devices shall describe the purposes they serve. The printed designation on unit or building information display systems indicators shall be legible. All conditions indicated shall remain displayed in accordance with the Equipment Requirements of this standard.

2. A unit information display system shall be so designed that the operation of any station in the unit shall cause a visible and audible signal.

3. Trouble displays shall be so arranged that the indicating device will reset automatically when the cause of the trouble has been removed. The trouble information display system shall be so designed that it will indicate visible and audible trouble signals in the event of trouble occurring on any circuit monitored. The trouble information display system shall be actuated by the operation of supervisory devices.

4. There shall be a silencing means for trouble signals that shall not affect subsequent trouble signals.

5. The information display systems shall be so designed that vibration from without or that caused by a trouble signal within will not operate the indicating devices.

6. All remote information display systems shall be installed in a separate steel cabinet painted Fire Department "red" and provided with approved lock and key. The information display system cabinets shall be marked in white letters at least one inch high with the words: "Fire Signal Information Display System, Zone . . .", or "Fire Signal Trouble Information Display System", whichever the case may be.

7. The information display systems shall be wall mounted and shall have the legend "Fire" in red letters three inches high together with an audible signal, in

Reference Standard 17

addition to the alphanumeric annunciation, and a separate and distinctive trouble signal shall sound. The audible signal accompanying an alarm shall be silenced when the equipment is operated by the Chief Building Administrator or his delegated substitute.

8. The display shall provide a minimum of four simultaneous alarm indications with an overflow memory for additional alarms. Provisions shall be made to distinguish alarm conditions from non alarm conditions. The display shall be updated as new information becomes available. If the same condition exists for more than one point on a floor or, for more than one floor in a building, a separate output entry shall be displayed for each point on the floor or floors.

9. Display Format. Each output entry shall include self identifying memory codes for the type of signal, building or area designation, floor or stair number and point location, and time of day.

10. Maintainability.

a. Manual display of all points of annunciation for test purposes shall be provided.

b. The capability shall be provided for interrogation of any station or sensing element for test purposes, either at the remote device or by interrogation from the office control location. Intervals for testing shall be as approved by the Fire Commissioner.

c. The equipment design shall be modular so that all repairs may be performed at the building site by substitution of duplicate components by authorized repair personnel.

d. On each one of those parts that are of a modular nature shall be included as spares at the control station.

K. LICENSED CONTRACTORS

Only a person holding a license or a special license in accordance with the provisions of the New York City Electrical Code shall install or alter the electrical wiring or apparatus for fire protective signal systems in any building.

L. USED OR REBUILT APPARATUS

Used apparatus shall not be re-used for any interior fire signal system until this used apparatus has been reconditioned in the shop of an approved manufacturer of interior fire alarm apparatus. Approval shall be obtained from the Commissioner prior to installation. The use of reconditioned apparatus whose manufacturer has discontinued manufacturing equipment is prohibited.

****DOB 4-13-03; DOB 1-9-02**

**** REFERENCE STANDARD RS 17-3A STANDARDS FOR THE INSTALLATION OF CLASS E, CLASS C AND CLASS J FIRE ALARM SIGNAL SYSTEMS**

(Note: References herein to Class E Systems shall be deemed to also include references to Class C and Class J Systems.)

1. (A) SOURCES OF ELECTRICAL POWER

Two sources of electrical power shall be provided as follows:

(1) The primary source shall be generated electric power not exceeding 277/480 volts, supplied by utility company power, or isolated plant.

(2) The secondary source shall be an emergency power system (as per 27-396), emergency generator and/or battery power.

One source of power shall be connected to the system at all times. The primary and secondary power sources shall be so arranged and controlled by automatic transfer switches and/or circuitry that when the primary source of power fails, the secondary source will be connected automatically to the fire alarm signal system. Intermediary devices between the system supply and the source of power, other than fused disconnect switches, transformers, fused cutouts and automatic transfer switches, are prohibited. Such disconnect switches, cutouts, transformers and automatic transfer switches shall supply only the fire alarm system and other Systems covered by this reference standard. When the utility company requires the installation of metering current transformers, the system supply shall be connected on the load side of the current transformers. All installations shall comply with the applicable sections of the New York City Electrical Code. The primary source of power and the secondary source (if emergency power system or generator) shall each be provided with a means of disconnect from the fire alarm system. For buildings supplied at 120/208 volts, each disconnect shall consist of a fused cutout panel, utilizing cartridge fuses, with provision for interrupting the unfused neutral and all ungrounded conductors. The neutral shall be provided with a removable solid copper bar. The incoming service neutral shall be bonded to the metallic housing of the cutout panel on the line side of the removable bar. The fused cutout panel housing shall consist of a locked metallic cabinet with a hinged door, painted fire department red, and permanently identified as to the system served. For buildings served at 265/460 volts, the primary and secondary service disconnects shall be fused disconnect switches (in lieu of fused cutout panels) in locked, red painted, permanently identified enclosures. The service voltage shall be transformed to 120/208 volts and a fused cutout panel provided within 5 feet of the transformer on the 120/208 volt side. The incoming supply connections shall comply with the NYC Electrical Code, and the fused cutout panel shall comply with the requirements specified hereinbefore.

(B) PRIMARY POWER SOURCE

1. The primary service to the fire alarm system shall be so arranged that the building source of supply can be disconnected without de-energizing the fire alarm supply. To accomplish this, the primary fire alarm supply shall be connected ahead of all building over current protection and/or switching devices.

2. Partial systems such as strobe light control panels, fire alarm, automatic smoke/heat detection, and sprinkler

Reference Standard 17

alarm subsystems and/or other associated systems may be connected to an emergency supply riser panel via a tapped connection, and identified, locked fused cutout box located within 5 feet of the tap.

Where an emergency power system is provided in accordance with section 27-396.4, it shall be connected to the emergency supply riser. Where an E.P.S. is not available, the emergency supply riser shall be connected to a tap ahead of the service switch.

(C) SECONDARY POWER SOURCE

The secondary service to the fire alarm system shall be provided as follows:

1. If the building has a required emergency power system, the secondary source shall be the emergency power system, regardless of whether the primary source is utility company power or an isolated plant.
2. If the building has an emergency generator supplying power to any of the loads listed in 27-396.4, the secondary source shall be the generator.
3. For all other buildings, the secondary source shall be a battery supply provided in accordance with Reference Standard 17-5 for storage batteries. The battery shall be designed for 24-hour supervisory operation of the system, followed by:
 - a. 6 hour total system load for systems with voice communication capability (A 45 minute period of voice/alarm operation at maximum connected load shall be considered equivalent to 6 hours of total systems operation), or
 - b. 15 minutes of total system load for systems without voice capability.
4. Partial systems and/or associated systems may derive their secondary supply from batteries whether or not the building is equipped with an emergency generator. Batteries shall be designed for 24-hour supervisory operation followed by 5 minutes of total system load. All alterations to any existing approved fire alarm system involving or consisting of the replacement of the Fire Command Station, Fire Alarm Control Panel, Central Processing Unit, Floor Control Units, Remote Control Units, Data Gathering Panels, Terminal Transmission Board, and other similar or equivalent controls or control panels shall be required to comply with Section C3 above. For systems in buildings, which are in compliance with Sections (C)1 or(C)2 above, compliance with Section (C)3 is optional.

2. Associated Systems. –

Associated systems listed below shall have their actuation added to the Fire Command Station.

- (a) Smoke detection systems.
- (b) Sprinkler waterflow alarms.
- (c) Thermostatic alarms.
- (d) Locked door-fail safe release systems.
- (e) Elevator communication and interconnection.
- (f) Stair pressurization fan(s) and associated damper(s)

3. Wiring. -

- a. Power Conductors (Above 75 volts) shall be:
 - (1) Copper: THHN, THWN/THHN, TFFN, TFN, FEP, RHH, RHW-2, XHH, or XHHW; minimum 600 volts; 90 C; for installation in rigid metallic conduit (RMC), intermediate metallic conduit (IMC) or electric metallic tubing (EMT).
 - (2) Cable type MI, M.E.A. approved for fire alarm service.
- b. Low Voltage Conductors (75 volts and less)
 - (1) Copper; THHN, THWN/THHN, TFFN, TFN, FEP, RHH, RHW-2, XHH, XHHW, minimum 600 volts; 90 C; for installation in rigid metallic conduit (RMC), intermediate metallic conduit (IMC), electric metallic tubing (EMT)
 - (2) Minimum wire size No. 18 AWG.
 - (3) Multi-conductor cables run in raceways, or exposed as described hereinafter, shall meet the following additional requirements:
 - a. Type FPLP only; minimum insulation thickness 15 mils; minimum temperature 150C; colored red.
 - b. Red colored jacket overall; minimum thickness 25 mils.
 - c. Cable printing as per UL1424; must bear additional description "ALSO CLASSIFIED NYC CERT. FIRE ALARM CABLE," legible without removing jacket.
 - c. Installation of Conductors and Raceway shall be in accordance with the following:
 - (1) Power conductors shall not be installed in common raceways with low voltage conductors.
 - (2) Shall comply with applicable requirements of New York City Electrical Code, except where requirements are exceeded by this Reference Standard.
 - (3) Conductors other than M.I. cable shall be run in raceway, except as specifically described below.
 - (4) Multi-conductor cables may be installed without raceway protection where cable is protected by building construction. Where not protected by building construction, cables shall be located 8 feet or more above the finished floor and not subject to physical tampering or hazard. Locations within eight feet of the finished floor that are deemed as "protected by building construction" shall include raised floors, shafts, telephone and communication equipment rooms and closets, and rooms used exclusively for fire alarm system equipment. In any suppression and extinguishing__system activated by automatic fire detection, including, but not limited to, pre-action sprinkler, deluge sprinkler, clean air agent, halon, range hood, CO2 and dry chemical, multi-conductor cables shall be installed in RMC, IMC, or EMT.
 - (5) All wiring within mechanical and elevator equipment rooms shall be run in raceway.
 - (6) Where wiring is required to be run in raceway, install conductors in rigid metallic conduit (RMC), intermediate metallic conduit (IMC) or electric metallic tubing (EMT); except that multi-conductor cables may also be run in surface metal raceway. Flexible metallic conduit, not exceeding 36" in length, shall be permitted

Reference Standard 17

for final connections to initiating and notification devices. Conductors for other electrical systems shall not be installed in raceways containing REFERENCE STANDARD 17 conductors.

(7) Where allowed to be run without raceway protection, multi-conductor cables shall be installed as follows:

a. Cables shall not depend on ceiling media, pipes, ducts, conduits, or equipment for support. Support independently from the building structure.

b. Secure by cable ties, straps or similar fittings, so designed and installed as not to damage the cable. Secure in place at intervals not exceeding 5'0" on centers and within 12" of every associated cabinet, box or fitting.

(8) Raceways run within 8 feet of finished floor in garage areas, loading docks, mechanical rooms, and elsewhere where subject to mechanical damage, shall be rigid galvanized steel conduit only.

(9) Installation of raceways, boxes and cabinets shall comply with the following general requirements.

a. Covers of boxes and cabinets shall be painted red and permanently identified as to their use.

b. Penetrations of fire-rated walls, floors or ceilings shall be fire stopped.

c. Within stairways, raceways within 8 feet of the floor shall not be installed so as to reduce or obstruct the stairway radius.

d. Raceways or cables shall not penetrate top of any equipment box or cabinet.

(10) All conduits supplying 120-volt power to the fire command station and/or fire alarm control unit and/or to outlying control cabinets, shall contain a green insulated grounding conductor sized in accordance with the New York City Electrical Code (#10 AWG minimum). The grounding conductor shall be connected to the ground bus or other suitable grounding terminal in each box and cabinet in which it enters. At the fuse cutout panel supplying the fire alarm system, provide a grounding electrode conductor sized and installed in accordance with the New York City Electrical Code (#10 AWG minimum).

(11) For cabinets whose 120-volt supply is not derived from the main fire alarm system cutout panel, provide green insulated separate grounding electrode conductors, sized and installed as per New York City Electrical Code (#10 AWG minimum). In steel, framed buildings, a connection to local steel structure will be acceptable.

(12) Splices and terminations of wires and cables shall be as follows:

a. Permitted only in boxes or cabinets specifically approved for the purpose.

b. Utilize mechanical connections specifically approved by U.L. 486 A & C for the conductors, or if soldered, first joined so as to be mechanically and electrically secure prior to soldering and insulating. Temperature

rating of completed splices shall equal or exceed the temperature rating of the highest rated conductor.

(13) Wiring for audible and visual alarm notification devices shall be arranged so that a loss of a portion of the wiring on a floor will not render more than 60% of the devices of each type inoperative, and the devices shall be so connected to the circuitry (i.e., by means of alternate circuits) as to maintain at least partial audibility/visibility throughout the entire floor.

4. Fire Alarm Sending Stations, Class "E" - Non-Coded Manual Station, and Floor Warden Station. -

(a) There shall be at least one (1) fire alarm sending station in each story of a building located in each path of escape. Additional stations shall be installed so that no point on any floor shall be more than 200 feet from the nearest station.

(b) A floor warden station on each floor shall be located between required stairways, required vertical exits or other required exits. All types of systems shall include a telephone type handset at the floor warden station with integral signaling to the fire command station and may be a part of the speaker system. The handset shall be red and equipped with armor over the wiring between the hand set and its housing which may be installed flush, semi-flush or surface mounted. The housing shall be painted red and identify its function. Equipment shall be installed with a box recessed or surface mounted large enough to include the hand set and test facility, by means of a key, to test the floor automatic and manual alarm device wiring. A pilot light shall indicate the live condition of the floor warden station.

Doors of sending stations shall be painted red and lettered "FIRE EMERGENCY - OPEN DOOR TO OPERATE" or words to this effect. Instructions for operating the station shall be permanently affixed or be an integral part of the station. Instruction cards shall be provided at each station protected by glass or plastic. Designation number of station shall be prominently displayed on instruction card or on cover of station.

(c) All current-carrying parts shall be insulated from parts carrying current of opposite polarity with approved insulating material.

(d) All pull-lever type stations shall be constructed with a door or other approved means to protect the "pull lever" against accidental injury. The wording "IN CASE OF FIRE - OPEN DOOR AND PULL DOWN LEVER" in raised letters or equivalent instructions, shall appear on the door.

(e) For systems using break-glass or break-rod type stations, at least one extra glass rod or glass pane for each station in the system shall be kept in the building. Break glass stations shall have the glass rod or pane mounted on the surface of the station covers or mounted internally in such a manner that the glass must be broken to actuate the sending station. Suitable hammers

Reference Standard 17

on chains attached to the stations or other approved means of breaking the glass, shall be provided. Stations accomplishing the "break glass" principle using other approved means shall not be required to provide hammers or spare glasses.

(f) Non Coded Stations:

(1) Non-coded closed circuit fire alarm stations may be operated by a break-glass or break-rod or a pull lever device so arranged that the alarm cannot be interfered with except by resetting or replacement of the glass or rod by an authorized person.

(2) The construction and materials shall be equivalent to that of the standard approved type coded closed circuit station described in reference standard RS 17-3 except that the contacts shall be of sufficient capacity to safely carry the entire operating current of the alarm circuit without excessive heating.

(g) Station Testing Devices - Provisions shall be made for a silent test of sending station mechanisms without operating the signaling devices. Such test device shall be designed to prevent any person, except those in authority, from operating the same and to prevent the possibility of the box being left inoperative after the test.

(h) Provision shall be made to supply an audible and visual signal at the fire command station from the floor warden station.

(i) A designated station on each floor shall have the capability of operating the loud speakers for that floor.

5. Alarm Sounding Devices. -

(a) Approved speakers shall be provided as the sounding devices. The alarm sound shall be a generated gong, bell, horn, whistle or other acceptable signal. Chime sounds may be installed only with the approval of the commissioner. Approved speakers shall have heat resistant driven elements and shall conform to reference standard RS 17-5.

When recessed speakers are used they shall conform to the performance requirements of reference standard RS 17-5. Speakers when mounted on walls shall be mounted upon tenant walls in preference to building core walls.

(b) Recessed speakers if used shall be located not more than 10 feet from the entrance to each required exit to insure proper alarm signal reproduction. This spacing is based upon normal 8 feet - 10 feet ceiling height. Surface mounted type speakers shall be mounted within 10 feet of each egress to insure proper alarm signal reproduction. For unusual conditions and higher ceilings, speakers shall not be mounted more than 20 feet above floor.

(c) The alarm sounding devices may be utilized for other audio purposes including building security if means is provided to insure fire alarm priority.

6. Fire Alarm System Control Boards and Command Stations. -

(a) Supervising Circuit. -

(1) Class "E" fire alarm systems shall be supervised.

(2) The supervising circuit shall be provided with a trouble signal arranged to sound continuously in case of failure of the primary power source. The trouble signal shall be so located that it will be within audible range of a responsible person in the building.

(3) Trouble signals may be fitted with silencing switches only when the switch is connected in such a manner that the act of silencing the signal by the operation of the switch automatically transfers the trouble signal to a red lamp on the fire command station. When the trouble has been repaired, the alarm signal shall sound until the silencing switch has been reset to operate under normal conditions.

(4) The trouble signal shall give a distinctive signal.

(b) Protection of Sending and Sounding Devices. -In fire alarm signal systems, sending stations and sounding devices shall be enclosed in metal casings, made dust proof and damp proof when necessary, and clearly marked with instructions for use.

(c) Standards of Electric Alarm Apparatus. -All electrically actuated apparatus used in fire alarm systems shall be so designed and constructed that it will operate satisfactorily at an input voltage level 15 per cent below or 10 per cent above normal rated voltage.

(d) Insulation. -

(1) Insulating materials used shall be varnished cambric, bakelite, mica, or equivalent insulating material.

(2) The use of fiber or paper as an insulating material is prohibited.

(3) The insulating materials used shall be capable of withstanding an insulation breakdown test of 1,000 volts a.c. plus twice operating voltage applied for 1 minute.

(e) Electromagnets. -

(1) Electromagnet windings shall be impregnated with an insulating, moisture repelling compound of the silicone or epoxy type.

(2) Electromagnet coils used on alternating current, when composed of enameled wire shall have additional approved insulation on each wire. The coils may be of the form-wound type.

(3) A protective cover to prevent mechanical damage shall be provided over the entire coil.

(4) Electromagnetic coils shall be fastened to prevent floating.

(5) Electromagnet cores shall be of the best grade of ferrous material so as to reduce to a minimum the possibility of failure due to residual magnetism.

(6) Electromagnet cores for use on alternating current shall be of laminated construction or other approved method to prevent heating and promote efficiency.

Reference Standard 17

(7) Electromagnetic cores of relays shall be treated to prevent corrosion. Paint or varnish shall not be used for this purpose.

(8) Non-magnetic freeze pins shall be used to prevent two magnetic surfaces from making physical contact with each other.

(f) Relays. -

(1) The armatures of all relays shall depend on gravity or magnetic attraction for their operation and may be assisted by a spring.

(2) Adjustments shall be of such a character that they can be securely locked.

(g) Overload protective devices. -Electronic circuits shall provide protection of all equipment and circuits by opening up the circuit to the equipment or devices protected. The operation of this "overload circuit" shall cause the trouble signal to sound at the fire command station.

(h) Control boards shall operate so that troubles in individual zones may be shunted out without affecting the rest of the system.

(i) Provision shall be made for sufficient wire gutter space around the panel. Gutter space shall be a minimum of 2 inches at sides, top, and bottom. Wire in gutter space shall be properly laced in a neat and workmanlike manner on all control boards.

(j) Conduit knockouts shall not be provided in the top of the control board cabinet, unless designed and approved for entry on top.

(k) A wiring diagram of the alarm system approved by the commissioner and the approved card of instruction properly marked and securely fastened shall be provided within the control board cabinet and at the fire command station. When it becomes necessary to mount the diagram outside of the cabinet, the diagram shall be framed under glass or equivalent material.

(l) Control Boards. -

(1) Control boards and amplifiers used for voice communication and alarms shall be located in a safe, moisture and dust free location secure from unauthorized tampering. Otherwise a ventilated cabinet provided with a lock and key, suitably identified, shall be provided.

(2) Amplifiers for class E systems shall have the capacity to deliver sufficient power to operate all alarm sounding devices and voice communication system and have a 50 per cent reserve power capacity. In addition the amplifiers shall be wired in such a manner that the imminent failure or actual failure of amplifiers shall shut down the amplifier and indicate a trouble condition. Removal of an amplifier shall be indicated by a trouble signal at the fire command station. Opening of the control cabinets shall be supervised by a tamper switch producing a manually resettable trouble alarm at the fire command station.

(m) Fire Command Station . -The fire command station shall contain all the components described in the

building code and shall have the capability of overriding floor warden stations. The command station console shall be provided with a hinged cover which permits the flashing "FIRE" visible signal to be seen. The cover shall be provided with an approved lock and key. The fire command station shall be provided with an information display system so located as to provide minimum distortion due to an angular line-of-sight and ambient lighting conditions. This display shall have the capability to monitor the following systems in order of listed priority:

- (1) Manual Fire Alarm
- (2) Smoke Detection
- (3) Sprinkler Waterflow
- (4) Elevator Lobby Detector
- (5) Fire Signal Activation
- (6) Central Office Notification
- (7) Fan System on - Fan System off
- (8) Fail Safe Locked Door
- (9) Fire Systems Trouble
- (10) Fire Signal Trouble
- (11) Tamper Switch Alarm
- (12) Power Source
- (13) Test/Normal Mode
- (14) Other Information as Desired
- (15) Stair pressurization fan(s) and associated damper(s).

7. Painting of Equipment. -All enclosing cases for fire alarm sprinkler alarm, smoke detection, and associated systems alarm apparatus shall be painted fire department red, except where approval is given by the commissioner to deviate from this requirement. The lobby information display system may be painted or finished to suit the owner of the building.

8. Information Display Systems. -

*(a) Information display systems used in connection with Class E Fire Alarm Signal Systems shall be of an approved electrically supervised type. The indicating devices shall describe the purpose they serve. The printed designation on unit or building information display system indicators shall be legible. The mechanism shall be so arranged that once operated, the indicating device must be reset manually. All conditions indicated shall remain displayed until manually cleared at the Fire Command Station. Fire Command Stations shall provide alarm information in a direct manner; no references to numeric codes shall be permitted. Where a CRT display is provided, a specially marked control shall be provided that will enable the system operator to determine the alarm source and other related pertinent information.

**Local Law 16-1984*

(b) A unit information display system shall be so designed that the operation of any station in the unit causes a visible and audible signal.

(c) Trouble displays shall be so arranged that the indicating device will reset automatically when the

Reference Standard 17

cause of trouble has been removed. The trouble information display system shall be so designed that it will indicate visible and audible trouble signals in the event of trouble occurring on any circuit monitored. The trouble information display system shall be actuated by the operation of supervisory devices.

(d) A silencing switch shall be provided for trouble signals, but shall not affect subsequent trouble signals.

(e) Information display systems shall be so designed that vibration from without or that caused by a trouble signal within will not operate the indicating devices.

(f) All remote information display systems shall be installed in a separate steel cabinet painted red, provided with approval lock and key. Information display system cabinets shall be marked in white letters at least one inch high with the words "FIRE ALARM INFORMATION DISPLAY SYSTEM, ZONE ----- " or "FIRE ALARM TROUBLE INFORMATION DISPLAY SYSTEM", whichever the case may be.

(g) Information display systems located in the lobby of a building whether an integral part of the fire command station or wall mounted shall have the legend "FIRE" in red letters three inches high together with an audible signal in addition to the lamp, target drop, cathode ray tube, light emitting diode, nixie, etc. and a separate or distinctive trouble signal shall sound. The audible signal accompanying an alarm shall be automatically silenced when the fire command station is operated by the fire safety director or his delegated substitute. Remote information display systems shall operate in the same manner.

(h) The display shall provide a minimum of four simultaneous alarm indicators with an overflow indication for additional alarms. Provisions shall be made to distinguish alarm conditions from non-alarm conditions. The display shall be updated as new information becomes available. If the same condition exists for more than one point on a floor or for more than one floor in a building, such as a fire gong actuation or public address, a separate output entry shall be displayed for each point or floor.

(i) Display format. - Each output entry shall include self-identifying mnemonic codes for the type of signal, building or area designation, floor or stair number and point location, and time of day. Systems utilizing gravity drops or lamps as point identification, may provide a hard copy print out.

(j) Maintainability. -

(1) Manual display of all points of annunciation for test purposes shall be provided.

(2) Capability shall be provided for interrogating any station or sensing element for test purposes, either at the remote device or by interrogation from the fire command station. Intervals of testing shall be as approved.

(3) Equipment designed shall be modular so that all repairs may be performed on-site by substitution of duplicate components by authorized personnel.

(4) One each of these parts that are of a modular nature shall be included as spares at the fire command station.

9. Licensed Contractors. -Only a person holding a license or a special license in accordance with the provisions of the New York city electrical code, shall install, alter, or repair electrical wiring or apparatus for fire alarm systems in any building.

10. Used or Rebuilt Apparatus. -Used apparatus shall not be re-used for any interior fire alarm system until the same has been reconditioned in the shop of any approved manufacturer of interior fire alarm apparatus. Approval shall be obtained from the commissioner prior to installation. The use of reconditioned apparatus whose manufacturer has discontinued manufacturing equipment is prohibited.

11. Standpipe Fireline Telephone and Signal System. - Where the standpipe telephone and signal system is arranged to be used as a modified class E fire alarm signal system as provided in the building code, retractable telephone handsets shall be provided in pump rooms. The telephone in pump rooms shall be equipped with a loudspeaking receiver so that a voice can be distinctly heard at least 15 feet from the receiver.

12. Locked Door Fail Safe Systems. -

(a) Stairway reentry doors which are locked from the stairway side as permitted in section C26-604.4 of the administrative code shall be provided with an electrical fail safe strike release mechanism that will permit the door to be opened without a key when any automatic fire detecting device operates, elevator "Fireman Service" operates or power failure shall occur. In addition, provisions shall be made to permit these doors to be opened from the command station or mechanical control center. This system shall be manually reset.

(b) Wiring for these systems shall comply with rule 6(a), (b), (c) and (d) of this reference standard and be electrically supervised for open and shorted or grounded circuits.

(c) Transformers for release mechanisms shall be rated for the proper use load, identified and located in proximity of the power supply for other fire alarm systems.

(d) The release mechanisms shall be operated from a separate control relay having the capability of indicating trouble on a separate trouble signal and at the information display system on the command console and at the mechanical control center. The mechanism shall also indicate a "failed" and "open" status on the command console and at the mechanical control center.

*(e) Where a fail-safe reentry door has been converted to conform to the requirements of this code by means of an electric strike release, provision shall be made to

Reference Standard 17

insure that the door will remain "Latched" even if "Unlocked".

**Local Law 16-1984*

13. Radio System. -A radio or radio/wire system shall comply with the following requirements:

(a) The emergency notification portion of the system equipment shall be capable of the following:

(1) Have the capability of individual, group or entire building notification of an alarm tone and voice intelligibility.

(2) Receivers and wire extension speakers shall be permanently mounted to a wall or pillar.

(3) There shall be automatic switch over to emergency battery power supply.

(b) Two way communication shall be accomplished by fixed transmitters and receivers.

(c) Equipment shall be Federal Communications Commission (FCC) approved, FM type, solid state, above 150.8 MHz. Selective signaling shall be accomplished by a minimum of 2 tone code operation.

(d) The antenna shall be designed and installed for use at the fire command station transmitter and be capable of transmitting to all fixed stations.

(e) The fire command station unit shall have the capability of locking out all other remote control points.

14. Sprinkler Waterflow Alarms. -A sprinkler waterflow alarm may be arranged to be used as part of a modified class E fire alarm signal system provided: the alarm signal system shall be an approved electrically supervised closed circuit information display system capable of indicating the floor where the sprinkler was activated.

15. Elevator communication:

Elevator intercommunication shall be acceptable for communications with the Fire Command Station if there is a means of communication proximate to the Fire Command Station.

***DOB 4-13-03; Local Law 16-1987; Local Law 16-1984; Local Law-5-1973*

**** REFERENCE STANDARD RS 17-3B STANDARDS FOR THE INSTALLATION OF MODIFIED CLASS E, AND MODIFIED CLASS J FIRE ALARM SIGNAL SYSTEMS**

(Note: References herein shall be deemed to also include references to Modified Class J Systems.)

1. (A) SOURCES OF ELECTRICAL POWER

Two sources of electrical power shall be provided as follows:

(1) The primary source shall be generated electric power not exceeding 277/480 volts, supplied by utility company power, or isolated plant.

(2) The secondary source shall be an emergency power system (as per 27-396), emergency generator and/or battery power.

One source of power shall be connected to the system at all times. The primary and secondary power sources shall be so arranged and controlled by automatic transfer switches and/or circuitry that when the primary source of power fails, the secondary source will be connected automatically to the fire alarm signal system. Intermediary devices between the system supply and the source of power, other than fused disconnect switches, transformers, fused cutouts and automatic transfer switches, are prohibited. Such disconnect switches, cutouts, transformers and automatic transfer switches shall supply only the fire alarm system and other Systems covered by this reference standard. When the utility company requires the installation of metering current transformers, the system supply shall be connected on the load side of the current transformers. All installations shall comply with the applicable sections of the New York City Electrical Code.

The primary source of power and the secondary source (if emergency power system or generator) shall each be provided with a means of disconnect from the fire alarm system. For buildings supplied at 120/208 volts, each disconnect shall consist of a fused cutout panel, utilizing cartridge fuses, with provision for interrupting the unfused neutral and all ungrounded conductors. The neutral shall be provided with a removable solid copper bar. The incoming service neutral shall be bonded to the metallic housing of the cutout panel on the line side of the removable bar. The fused cutout panel housing shall consist of a locked metallic cabinet with a hinged door, painted fire department red, and permanently identified as to the system served. For buildings served at 265/460 volts, the primary and secondary service disconnects shall be fused disconnect switches (in lieu of fused cutout panels) in locked, red painted, permanently identified enclosures. The service voltage shall be transformed to 120/208 volts and a fused cutout panel provided within 5 feet of the transformer on the 120/208 volt side. The incoming supply connections shall comply with the NYC Electrical Code, and the fused cutout panel shall comply with the requirements specified hereinbefore.

(B) PRIMARY POWER SOURCE

1. The primary service to the fire alarm system shall be so arranged that the building source of supply can be disconnected without de-energizing the fire alarm supply. To accomplish this, the primary fire alarm supply shall be connected ahead of all building over current protection and/or switching devices.

2. Partial systems such as strobe light control panels, partial fire alarm, automatic smoke/heat detection, and sprinkler alarm subsystems and/or other associated systems may be connected to an emergency supply riser panel via a tapped connection, and identified, locked fused cutout box located within 5 feet of the tap.

Reference Standard 17

Where an emergency power system is provided in accordance with section 27-396.4, it shall be connected to the emergency supply riser. Where an E.P.S. is not available, the emergency supply riser shall be connected to a tap ahead of the service switch.

(C) SECONDARY POWER SOURCE

The secondary service to the fire alarm system shall be provided as follows:

1. If the building has a required emergency power system, the secondary source shall be the emergency power system, regardless of whether the primary source is utility company power or an isolated plant.

2. If the building has an emergency generator supplying power to any of the loads listed in 27-396.4, the secondary source shall be the generator.

3. For all other buildings, the secondary source shall be a battery supply provided in accordance with Reference Standard 17-5 for storage batteries. The battery shall be designed for 24-hour supervisory operation of the system, followed by:

a. 6 hour total system load for systems with voice communication capability (A 45 minute period of voice/alarm operation at maximum connected load shall be considered equivalent to 6 hours of total systems operation), or

b. 15 minutes of total system load for systems without voice capability.

4. Partial systems and/or associated systems may derive their secondary supply from batteries whether or not the building is equipped with an emergency generator. Batteries shall be designed for 24-hour supervisory operation followed by 5 minutes of total system load.

All alterations to any existing approved fire alarm system involving or consisting of the replacement of the Fire Command Station, Fire Alarm Control Panel, Central Processing Unit, Floor Control Units, Remote Control Units, Data Gathering Panels, Terminal Transmission Board, and other similar or equivalent controls or control panels shall be required to comply with Section C3 above. For systems in buildings, which are in compliance with Sections (C)1 or (C)2 above, compliance with Section (C)3 is optional.

2. Associated Systems. –

Associated systems listed below shall have their actuation added to the Fire Command Station.

- (a) Smoke detection systems
- (b) Sprinkler waterflow alarms
- (c) Thermostatic alarms
- (d) Locked door-fail safe release systems
- (e) Elevator communication and interconnection.

3. Wiring. –

a. Power Conductors (Above 75 volts) shall be:

(1) Copper: THHN, THWN/THHN, TFFN, TFN, FEP, RHH, RHW-2, XHH, or XHHW; minimum 600 volts;

90 C; for installation in rigid metallic conduit (RMC), intermediate metallic conduit (IMC) or electric metallic tubing (EMT).

(2) Cable type MI, M.E.A. approved for 2-hour fire resistance rating.

b. Low Voltage Conductors (75 volts and less)

(1) Copper; THHN, THWN/THHN, TFFN, TFN, FEP, RHH, RHW-2, XHH, XHHW, minimum 600 volts; 90 C; for installation in rigid metallic conduit (RMC), intermediate metallic conduit (IMC), electric metallic tubing (EMT), and

(2) Minimum wire size No. 18 AWG.

(3) Multi-conductor cables run in raceways, or exposed as described hereinafter, shall meet the following additional requirements:

a. Type FPLP only; minimum insulation thickness 15 mils; minimum temperature 150C; colored red.

b. Red colored jacket overall; minimum thickness 25 mils.

c. Cable printing as per UL1424; must bear additional description "ALSO CLASSIFIED NYC CERT. FIRE ALARM CABLE," legible without removing jacket.

c. Installation of Conductors and Raceway shall be in accordance with the following:

(1) Power conductors shall not be installed in common raceways with low voltage conductors.

(2) Shall comply with applicable requirements of New York City Electrical Code, except where requirements are exceeded by this Reference Standard.

(3) Conductors other than M.I. cable shall be run in raceway, except as specifically described below.

(4) Multi-conductor cables may be installed without raceway protection where cable is protected by building construction. Where not protected by building construction, cables shall be located 8 feet or more above the finished floor and not subject to physical tampering or hazard. Locations within eight feet of the finished floor that are deemed as "protected by building construction" shall include raised floors, shafts, telephone and communication equipment rooms and closets, and rooms used exclusively for fire alarm system equipment. In any suppression and extinguishing system activated by automatic fire detection, including, but not limited to, pre-action sprinkler, deluge sprinkler, clean air agent, halon, range hood, CO2 and dry chemical, multi-conductor cables shall be installed in RMC, IMC, or EMT.

(5) All wiring within mechanical and elevator equipment rooms shall be run in raceway.

(6) Raceways run within 8 feet of finished floor in garage areas, loading docks, mechanical rooms, and elsewhere where subject to mechanical damage, shall be rigid galvanized steel conduit only.

(7) Where wiring is required to be run in raceway, install conductors in rigid metallic conduit (RMC), intermediate metallic conduit (IMC) or electric metallic tubing (EMT); except that multi-conductor cables may also be run in surface metal raceway. Flexible metallic

Reference Standard 17

conduit, not exceeding 36" in length, shall be permitted for final connections to initiating and notification devices. Conductors for other electrical systems shall not be installed in raceways containing REFERENCE STANDARD 17 conductors.

(8) Where allowed to be run without raceway protection, multi-conductor cables shall be installed as follows:

a. Cables shall not depend on ceiling media, pipes, ducts, conduits, or equipment for support. Support independently from the building structure.

b. Secure by cable ties, straps or similar fittings, so designed and installed as not to damage the cable. Secure in place at intervals not exceeding 5'0" on centers and within 12" of every associated cabinet, box or fitting.

(9) Installation of raceways, boxes and cabinets shall comply with the following general requirements.

a. Covers of boxes and cabinets shall be painted red and permanently identified as to their use.

b. Penetrations of fire-rated walls, floors or ceilings shall be fire stopped.

c. Within stairways, raceways within 8 feet of the floor shall not be installed so as to reduce or obstruct the stairway radius.

d. Raceways or cables shall not penetrate top of any equipment box or cabinet.

(10) All conduits supplying 120-volt power to the fire command station and/or fire alarm control unit and/or to outlying control cabinets, shall contain a green insulated grounding conductor sized in accordance with the New York City Electrical Code (#10 AWG minimum). The grounding conductor shall be connected to the ground bus or other suitable grounding terminal in each box and cabinet in which it enters. At the fuse cutout panel supplying the fire alarm system, provide a grounding electrode conductor sized and installed in accordance with the New York City Electrical Code (#10 AWG minimum).

(11) For cabinets whose 120-volt supply is not derived from the main fire alarm system cutout panel, provide green insulated separate grounding electrode conductors, sized and installed as per New York City Electrical Code (#10 AWG minimum). In steel, framed buildings, a connection to local steel structure will be acceptable.

(12) Splices and terminations of wires and cables shall be as follows:

a. Permitted only in boxes or cabinets specifically approved for the purpose.

b. Utilize mechanical connections specifically approved by U.L. 486 A & C for the conductors, or if soldered, first joined so as to be mechanically and electrically secure prior to soldering and insulating. Temperature rating of completed splices shall equal or exceed the temperature rating of the highest rated conductor.

(13) Wiring for audible and visual alarm notification devices shall be arranged so that a loss of a portion of the wiring on a floor will not render more than 60% of

the devices of each type inoperative, and the devices shall be so connected to the circuitry (i.e., by means of alternate circuits) as to maintain at least partial audibility/visibility throughout the entire floor.

4. Fire Alarm Sending Stations, Modified Class "E" - Non-Coded Manual Station and Floor Warden Station. -

(a) There shall be at least one (1) fire alarm sending station in each story of a building located in each path of escape. Additional stations shall be installed so that no point on any floor shall be more than 200 feet from the nearest station.

(b) A floor warden station on each floor shall be located between required stairways, required vertical exits or other required exits. All types of systems shall include a telephone type handset at the floor warden station with integral signaling to the fire command station and may be a part of the speaker system. The hand set shall be red and equipped with armor over the wiring between the hand set and its housing which may be installed flush, semi-flush or surface mounted. The housing shall be painted red and identify its function. Equipment shall be installed within a box recessed or surface mounted, large enough to include the hand set and test facility, by means of a key, to test the floor automatic and manual alarm device wiring. A pilot light shall indicate the live condition of the floor warden station.

Doors of sending stations shall be painted red and lettered "FIRE EMERGENCY - OPEN DOOR TO OPERATE" or words to this effect. Instructions for operating the station shall be permanently affixed or be an integral part of the station. Instruction cards shall be provided at each station protected by glass or plastic. Designation number of station shall be prominently displayed on instruction card or on cover of station.

(c) All current-carrying parts shall be insulated from parts carrying current of opposite polarity with approved insulating material.

(d) All pull-lever type stations shall be constructed with a door or other approved means to protect the "pull lever" against accidental injury. The wording "IN CASE OF FIRE - OPEN DOOR AND PULL DOWN LEVER" in raised letters or equivalent instructions, shall appear on the door.

(e) For systems using break-glass or break-rod type stations, at least one extra glass rod or glass pane for each station the system shall be kept in the building. Break glass stations shall have the glass rod or pane mounted on the surface of the station covers or mounted internally in such manner that the glass must be broken to actuate the sending station. Suitable hammers on chains attached to the stations or other approved means of breaking the glass, shall be provided. Stations accomplishing the "break glass" principle using other approved means shall not be required to provide hammers or spare glasses.

(f) Non-coded stations. -

Reference Standard 17

(1) Non-coded closed circuit fire alarm stations may be operated by a break-glass or break-rod or a pull lever device so arranged that the alarm cannot be interfered with except by resetting or replacement of the glass or rod by an authorized person.

(2) The construction and materials shall be equivalent to that of the standard approved type coded closed circuit station described in reference standard RS 17-3 except that the contacts shall be of sufficient capacity to safely carry the entire operating current of the alarm circuit without excessive heating.

(g) Station testing devices. - Provisions shall be made for a silent test of sending station mechanisms without operating the signaling devices. Such test device shall be designed to prevent any person, except those in authority, from operating the same and to prevent the possibility of the box being left inoperative after the test.

(h) Provision shall be made to supply an audible and visual signal at the fire command station from the floor warden station.

5. Alarm Sounding Devices. -

(a) Approved speakers shall be provided as the sounding devices. The alarm sound shall be a generated gong, bell, horn, whistle or other acceptable signal. Chime sounds may be installed only with the approval of the commissioner. Approved speakers shall have heat resistant driven elements and shall conform to reference standard RS 17-5.

When recessed speakers are used they shall conform to the performance requirements of reference standard RS 17-5. Speakers when mounted on walls shall be mounted upon tenant walls in preference to building core walls.

(b) Recessed speakers if used shall be located not more than 10 feet from the entrance to each required exit to insure proper alarm signal reproduction. This spacing is based upon normal 8 feet-10 feet ceiling height. Surface mounted type speakers shall be mounted within 10 feet of each egress to insure proper alarm signal reproduction. For unusual conditions and higher ceilings, speakers shall not be mounted more than 20 feet above floor.

(c) The alarm sounding devices may be utilized for other audio purposes including building security if means is provided to insure fire alarm priority.

6. Fire Alarm System Control Boards and Command Stations. -

(a) Supervising circuit. -

(1) Modified class "E" fire alarm systems shall be supervised.

(2) The supervising circuit shall be provided with a trouble signal arranged to sound continuously in case of failure of the power source. The trouble signal shall be

so located that it will be within audible range of a responsible person in the building.

(3) Trouble signals may be fitted with silencing switches only when the switch is connected in such a manner that the act of silencing the signal by the operation of the switch automatically transfers the trouble signal to a red lamp on the fire command station. When the trouble has been repaired, the alarm signal shall sound until the silencing switch has been reset to operate under normal conditions.

(4) The trouble signal shall give a distinctive signal.

(b) Protection of sending and sounding devices. -In fire alarm signal systems, sending stations and sounding devices shall be enclosed in metal casings, made dust proof and damp proof when necessary, and clearly marked with instructions for use.

(c) Standards of electric alarm apparatus. -All electrically actuated apparatus used in fire alarm systems shall be so designed and constructed that it will operate satisfactorily at an input voltage level 15 per cent below or 10 per cent above normal rated voltage.

(d) Insulation. -

(1) Insulating materials used shall be varnish cambric, bakelite, mica, or equivalent insulating material.

(2) The use of fiber or paper as an insulating material is prohibited.

(3) The insulating materials used shall be capable of withstanding an insulation breakdown test of 1,000 volts a.c. plus twice operating voltage applied for 1 minute.

(e) Electromagnets. -

(1) Electromagnet windings shall be impregnated with an insulating, moisture repelling compound of the silicone or epoxy type.

(2) Electromagnet coils used on alternating current, when composed of enameled wire shall have additional approved insulation on each wire. The coils may be of the form-wound type.

(3) A protective cover to prevent mechanical damage shall be provided over the entire coil.

(4) Electromagnetic coils shall be fastened to prevent floating.

(5) Electromagnet cores shall be of the best grade of ferrous material so as to reduce to a minimum the possibility of failure due to residual magnetism.

(6) Electromagnet cores for use on alternating current shall be of laminated construction or other approved method to prevent heating and promote efficiency.

(7) Electromagnetic cores of relays shall be treated to prevent corrosion. Paint or varnish shall not be used for this purpose.

(8) Non-magnetic freeze pins shall be used to prevent two magnetic surfaces from making physical contact with each other.

(f) Relays. -

Reference Standard 17

(1) The armatures of all relays shall depend on gravity or magnetic attraction for their operation and may be assisted by a spring.

(2) Adjustments shall be of such a character that they can be securely locked.

(g) Overload protective devices. -Electronic circuits shall provide protection of all equipment and circuits by opening up the circuit to the equipment or devices protected. The operation of this "overload circuit" shall cause the trouble signal to sound at the fire command station.

(h) Control boards shall operate so that troubles in individual zones may be shunted out without affecting the rest of the system.

(i) Provision shall be made for sufficient wire gutter space around the panel. Gutter space shall be a minimum of 2 inches at sides, top, and bottom. Wire in gutter space shall be properly laced in a neat and workmanlike manner on all control boards.

(j) Conduit knockouts shall not be provided in the top of the control board cabinet unless designed and approved for entry on top.

(k) A wiring diagram of the alarm system approved by the commissioner and the approved card of instruction properly marked and securely fastened shall be provided within the control board cabinet and at the fire command station. When it becomes necessary to mount the diagram outside of the cabinet, the diagram shall be framed under glass or equivalent material.

(l) Control boards. -

(1) Control boards and amplifiers used for voice communication and alarms shall be located in a safe, moisture and dust free location secure from unauthorized tampering. Otherwise a ventilated cabinet provided with a lock and key, suitably identified, shall be provided.

(2) Amplifiers for modified class "E" systems shall have the capacity to deliver sufficient power to operate all alarm sounding devices and voice communication system and have a 50 per cent reserve power capacity. In addition the amplifiers shall be wired in such a manner that the imminent failure or actual failure of amplifiers shall shut down the amplifier and indicate a trouble condition. Removal of an amplifier shall be indicated by a trouble signal at the fire command station. Opening of the control cabinets shall be supervised by a tamper switch producing a manually resettable trouble alarm at the fire command station.

(m) Fire command station. -The fire command station shall contain all the components described in the building code and shall have the capability of overriding floor warden stations, The command station console shall be provided with a hinged cover which permits the flashing "FIRE" visible signal to be seen, The cover shall be provided with an approved lock and key. The fire command station shall be provided with an information display system so located as to provide minimum distortion due to an angular line-of-sight and ambient lighting

conditions. This display shall have the capability to monitor the following systems in order of listed priority:

- (1) Manual Fire Alarm
- (2) Smoke Detection
- (3) Sprinkler Waterflow
- (4) Elevator Lobby Detector
- (5) Fire Signal Activation
- (6) Central Office Notification
- (7) Fan System On - Fan System Off
- (8) Fail Safe Locked Door
- (9) Fire Systems Trouble
- (10) Fire Signal Trouble
- (11) Tamper Switch Alarm
- (12) Power Source
- (13) Test/Normal Mode
- (14) Other Information as Desired

7. Painting of Equipment. -All enclosing cases for fire alarm, sprinkler alarm, smoke detection, and associated systems alarm apparatus shall be painted fire department red, except where approval is given by the commissioner to deviate from this requirement, The lobby information display system may be painted or finished to suit the owner of the building.

8. Information Display Systems. -

(a) Information display systems used in connection with modified class E fire alarm signal systems shall be of an approved electrically supervised type. The indicating devices shall describe the purpose they serve. The printed designation on unit or building information display system indicators shall be legible. The mechanism shall be so arranged that once operated, the indicating device must be reset manually. All conditions indicated shall remain displayed until manually cleared at the fire command station.

(b) A unit information display system shall be so designed that the operation of any station in the unit causes a visible and audible signal.

(c) Trouble displays shall be so arranged that the indicating device will reset automatically when the cause of trouble has been removed. The trouble information display system shall be so designed that it will indicate visible and audible trouble signals in the event of trouble occurring on any circuit monitored. The trouble information display system shall be actuated by the operation of supervisory devices.

(d) A silencing switch shall be provided for trouble signals, but shall not affect subsequent trouble signals.

(e) Information display systems shall be so designed that vibration from without or that caused by a trouble signal within will not operate the indicating devices.

(f) All remote information display systems shall be installed in a separate steel cabinet painted red, provided with approved lock and key. Information display system cabinets shall be marked in white letters at least one inch high with the words: "FIRE ALARM

Reference Standard 17

INFORMATION DISPLAY SYSTEM, ZONE -----" or "FIRE ALARM TROUBLE INFORMATION DISPLAY SYSTEM", whichever the case may be.

(g) Information display systems located in the lobby of a building whether an integral part of the fire command station or wall mounted shall have the legend "FIRE" in red letters three inches high together with an audible signal in addition to the lamp, target drop, cathode ray tube, light emitting diode, nixie, etc. and a separate or distinctive trouble signal shall sound. The audible signal accompanying an alarm shall be automatically silenced when the fire command station is operated by the fire safety director or his delegated substitute. Remote information display systems shall operate in the same manner.

(h) The display shall provide a minimum of four simultaneous alarm indicators with an overflow indication for additional alarms. Provisions shall be made to distinguish alarm conditions from non-alarm conditions. The display shall be updated as new information becomes available. If the same condition exists for more than one point on a floor or for more than one floor in a building, such as a fire gong actuation or public address, a separate output entry shall be displayed for each point or floor.

(i) Display format. - Each output entry shall include self-identifying mnemonic codes for the type of signal, building or area designation, floor or stair number and point location, and time of day. Systems utilizing gravity drops or lamps as point identification, may provide a hard copy print out.

(j) Maintainability. -

(1) Manual display of all points of annunciation for test purposes shall be provided.

(2) Capability shall be provided for interrogating any station or sensing element for test purposes, either at the remote device or by interrogation from the fire command station. Intervals of testing shall be as approved.

(3) Equipment design shall be modular so that all repairs may be performed on-site by substitution of duplicate components by authorized personnel.

(4) One each of these parts that are of a modular nature shall be included as spares at the fire command station.

9. Licensed Contractors. -Only a person holding a license or a special license in accordance with the provisions of the New York city electrical code, shall install, alter, or repair electrical wiring or apparatus for fire alarm systems in any building.

10. Used or Rebuilt Apparatus. -Used apparatus shall not be re-used for any interior fire alarm system until the same has been reconditioned in the shop of any approved manufacturer of interior fire alarm apparatus. Approval shall be obtained from the commissioner prior to installation. The use of reconditioned apparatus

whose manufacturer has discontinued manufacturing equipment is prohibited.

11. Standpipe Fireline Telephone and Signal System. -

Where the standpipe telephone and signal system is arranged to be used as a modified class E fire alarm signal system as provided in the building code, retractable telephone handsets shall be provided in pump rooms. The telephone in pump rooms shall be equipped with a loudspeaking receiver so that a voice can be distinctly heard at least 15 feet from the receiver.

12. Locked Door Fail Safe Systems. -

(a) Stairway reentry doors which are locked from the stairway side as permitted in section 27-371 of the administrative code shall be provided with an electrical fail safe strike release mechanism that will permit the door to be opened without a key when any automatic fire detecting device operates, elevator "Fireman Service" operates or power failure shall occur. In addition, provisions shall be made to permit these doors to be opened from the command station or mechanical control center. This system shall be manually reset.

(b) Wiring for these systems shall be electrically supervised for open and shorted or grounded circuits.

(c) Transformers for release mechanisms shall be rated for the proper use load, identified and located in proximity of the power supply for other fire alarm systems.

(d) The release mechanisms shall be operated from a separate control relay having the capability of indicating trouble on a separate trouble signal and at the information display system on the command console and at the mechanical control center. The mechanism shall also indicate a "failed" and "open" status on the command console and at the mechanical control center.

13. Radio System. -A radio or radio/wire system shall comply with the following requirements:

(a) The emergency notification portion of the system equipment shall be capable of the following:

(1) Have the capability of individual, group or entire building notification of an alarm tone and voice intelligibility.

(2) Receivers and wire extension speakers shall be permanently mounted to a wall or pillar.

(3) There shall be automatic switch over to emergency battery power supply.

(b) Two-way communication shall be accomplished by fixed transmitters and receivers.

(c) Equipment shall be Federal Communications Commission (FCC) approved, FM type, solid state, above 150.8 MHz. Selective signaling shall be accomplished by a minimum of 2 tone code operation.

(d) The antenna shall be designed and installed for use at the fire command station transmitter and be capable of transmitting to all fixed stations.

Reference Standard 17

(e) The fire command station unit shall have the capability of locking out all other remote control points.

14. Sprinkler Waterflow Alarms. -A sprinkler waterflow alarm may be arranged to be used as part of a modified class E fire alarm signal system provided: the alarm signal system shall be an approved electrically supervised closed circuit information display system capable of indicating the floor where the sprinkler was activated.

15. Elevator communication:

Elevator intercommunication shall be acceptable for communications with the Fire Command Station if there is a means of communication proximate to the Fire Command Station.

**Local Law 16-1984*

***DOB 4-13-03; DOB 1-9-02; Local Law 16-1987; Local Law 5-1973; 49-74 BCR*

** REFERENCE STANDARD RS 17-3C STANDARDS FOR THE INSTALLATION OF VISUAL AND AUXILIARY ALARMS REQUIRED BY SECTION 27-292.15

1. Definitions.

(a) Visual Alarms (Strobe): Visual alerting device which when activated by either an integral or an external initiating device provides an alarm signal in the form of a flashing high intensity light source (usually xenon) with frequency approximately of one (1) Hz.

(1) System Type Strobe: A strobe connected by direct wiring to an overall fire alarm system and upon which it depends for its actuating signal.

(2) Extension Type Strobe: A strobe connected by direct wiring to a single station smoke detector and upon which it depends for its actuating signal.

(b) Auxiliary Alarms. -

(1) Portable System Type Strobe: Strobe equipped with cord and plug (power supply), and a receiver arranged to detect the presence of the alarm tone, emitted by the fire alarm system thereby causing it to operate (flash).

2. General Requirements. -

(a) An installation of a new fire alarm and signal system incorporating audible devices intended to evacuate building occupants shall require strobes to be installed as part of the system.

(b) Installation of strobes in existing buildings may either be installed as part of an interior fire alarm and signal system or be connected to an approved strobe control panel.

3. Power Supply. -

(a) Except as noted in (b) below, strobes that are subject to the requirements of section two above, shall derive power from the interior fire alarm and signal system.

(b) When not powered by the interior fire alarm and signal system, independent strobe control panels shall supply power to strobes. Such control panels shall derive their power from a normal or emergency 120 volt source supplying the floor, via a separately installed locked fire alarm cutout connected to electrical supply in accordance with the requirements of the Electrical Code.

4. Strobe Control Panel. -

(a) A strobe control panel shall be approved by the Bureau of Electrical Control or approved by the Board of Standards and Appeals.

(b) The panel shall cause fire alarm signal received from interior fire alarm system to activate strobes.

(c) The panel shall have a battery and charger capable of providing at least fifteen (15) minutes of full system alarm operation following twenty four (24) hours of supervisory operation.

(d) Strobes may be reset from the fire command station by an identified reset device. When strobes cannot be turned off from the fire command station, a timer to shut off the strobes and reset the panel five (5) minutes after they are activated shall be provided in the panel.

(e) The panel shall incorporate electrical supervision of

(1) Alarm circuitry for strobes,

(2) Initiating circuitry from the building fire alarm system.

(3) The 120 VAC power source, and battery.

(f) The panel shall have a trouble contact for reporting to the interior fire alarm and signal system and shall have remote trouble bell.

(g) The panel shall be capable of disconnecting any flashing or in-motion lighting that may make strobes ineffective.

(5) Wiring. -The flashing strobes powered either through an interior fire alarm and signal system or independently through a control panel shall operate in conjunction with the audible signals and shall:

(a) Meet the requirements of Reference Standard RS 17-3A when required in a Class E, Class C and Class J fire alarm signal and signal system.

(b) Meet the requirements of Reference Standard RS 17-3B when required in a Modified Class E and Modified Class J fire alarm and signal system and

(c) Meet the requirements of Reference Standard RS 17-3 when required in any other fire alarm and signal system.

6. Portable System Type Strobe. -

(a) The strobe shall have a battery and charger capable of providing at least five (5) minutes of strobe operation following twenty-four (24) hours or supervisory operations.

(b) The strobe shall have a visual trouble indication when power is lost.

7. Location of Strobes. -

Reference Standard 17

(a) When strobes are installed on walls, they shall be a minimum of 80 inches above the floor or a maximum of 6 inches below the ceiling.

(b) When strobes are installed in ceilings, there shall be no other devices (such as exit lights) or building appurtenances (such as beams or smoke curtains) within 5 feet of the strobe.

****DOB 4-13-03; 886-89 BCR**

**** REFERENCE STANDARD RS 17-3D**

Repealed

****Local Law 16-1987**

† REFERENCE STANDARD RS 17-4

ANSI/NFPA No. 214-1988-Standard on Water Cooling Towers.

†310-90 BCR; 633-83 BCR

**** REFERENCE STANDARD RS 17-5**

ANSI/NFPA No. 72-1993 - National Fire Alarm Code. The provisions of NFPA 72-1993 with the exception of Chapter 2 shall apply subject to the following modifications. The section and paragraph numbers are from that standard.
Note: Chapter 2 of NFPA 72-1993 entitled "Household Fire Warning Equipment" shall not be part of this reference standard.

The requirement of NICET Certification as outlined under Section 7-1.2.3 shall be applicable beginning on January 14, 2006.

CHAPTER 1 - FUNDAMENTALS OF FIRE ALARM SYSTEMS

Add the definition of Evacuation Zone between Evacuation Signal and Exit Plan in Section 1-4.

Evacuation Zone. – An evacuation zone is an area of a floor, an entire floor, several floors or the entire building that is always intended to be evacuated simultaneously.

Amend the following definitions:

Section 1-5.2.3 – Delete exceptions No. 1 and No. 2.

Section 1-5.2.6 – Delete sub-paragraph (c).

Section 1-5.2.8.4 B Delete

Section 1-5.2.9.2(c) B Delete

Section 1-5.2.10 - Delete in its entirety.

Section 1-5.2.11 - Delete in its entirety.

Section 1-5.4.1 - Delete

Section 1-5.4.2.1 is modified as follows:

Section 1-5.4.2.1 Coded Alarm Signal - A coded alarm signal shall consist of not less than [three] four complete rounds of the number transmitted, and each round shall consist of not less than three impulses.

Section 1-5.4.3 - Delete in its entirety.

Section 1-5.4.7 - Delete the exception.

Section 1-5.4.8 Delete and substitute the following:

Section 1-5.4.8 Alarm Signal (*Silence*). – A means of silencing the alarm notification appliances shall be located within a locked F.A. Control Cabinet. Such a means shall be permitted only if a visible zone alarm indication or equivalent has been provided, as specified in 1-5.7, and subsequent alarms on other initiating

device circuits will cause the notification appliances to reactivate. A means that is left in the "off" position when there is no alarm shall operate an audible visible trouble signal until the means is restored to normal.

Section 1-5.4.10 - Delete

Section 1-5.5.4 - Delete

Section 1-5.6 - Delete

Section 1-5.7.1.1 - Delete the first paragraph up to . . . "in a fire situation."

Section 1-5.8.1 - Delete "within 200 seconds" from the end of the paragraph. Also delete "Exception #10."

Section 1-5.8.4 - Delete "exception #3."

Section 1-5.8.5.1 - Delete the exception of Subsection (b).

Section 1-5.8.6.1 - Delete exceptions #3 and #4.

Section 1-5.8.6.2 - Delete

Section 1-5.8.6.3 - Delete

Section 1-7 - Delete in its entirety.

CHAPTER 3 - PROTECTED PREMISES FIRE ALARM SYSTEMS

Section 3-2.1 - Delete

Section 3-3 - Delete subdivisions (h), (i) & (k)

Section 3-4.2 - Delete exceptions #3 and #5

Section 3-5.2 - Delete

Section 3-5.3 - Delete

Section 3-7.2(a) - Delete the effective date of the requirements.

Section 3-8.1.2 - Amended to read as follows:

Section 3-8.1.2 – For fire alarm systems employing automatic fire detectors or waterflow detection devices, at least one fire alarm box shall be provided to initiate [a] the same fire alarm signal as required by automatic fire detectors or waterflow detection devices. This fire alarm box shall be located where required by the authority having jurisdiction.

Section 3-8.3 - Delete

Section 3-8.6.2 shall be modified to read as follows:

Section 3-8.6.2 – A dry-pipe or preaction sprinkler system that is supplied with water by a connection beyond (downstream from) the alarm initiating device of a wet-pipe system shall be equipped with a separate waterflow alarm initiating pressure switch or other approved means to initiate a waterflow alarm.

Section 3-8.9.1 – Modify to read as follows: The operation of an automatic fire suppression system installed within the protected premises shall be indicated as an alarm on the protected premises fire alarm system.

Section 3-8.10.1 - Delete last paragraph starting from "all phases . . ."

Section 3-8.10.2 - Delete

Section 3-8.14 - Delete in its entirety.

Section 3-8.15.4 - Modify second sentence to read as follows: The operation of the elevators shall be in accordance with [ANSI/ASME A17.1, *Safety Code for Elevators and Escalators*, Rules 211.3 through 211.8] RS 18-1. Delete the third sentence.

Section 3-8.15.4 (a) - Delete

Section 3-8.15.4 (b) - Delete

Reference Standard 17

Section 3-8.16 - Delete.

Section 3-9.2.3 Modify to read as follows: When permitted by the authority having jurisdiction. Transfer of data over listed communication ports shall be an acceptable means of interfacing between the fire alarm control unit and fire safety function control devices.

Section 3-9.3.3 B Delete and substitute the following: Section 3-9.3.3 – Connections between fire alarm systems and the HVAC system for the purpose of monitoring and control shall be arranged such that primary control (the control that all other controls are secondary or subservient to) capability rests with the fire alarm control unit(s) under all circumstances, and in addition, shall operate and be monitored in accordance with Reference Standards RS 13-1, RS 17 and the authority having jurisdiction.

Add Section 3-9.3.4 as follows:

Section 3-9.3.4 – Those HVAC fans or fan systems which have been automatically shut-down by virtue of the activation of any fire alarm control unit or device shall be arranged and equipped not to automatically restart when the fire alarm control unit or device is reset. At least two manual means of restarting the fans or fan systems shall be required, such as manually resetting the fire alarm control unit or device and the manually resetting the fan or fan system controls.

Add Section 3-9.3.5 as follows:

Section 3-9.3.5 – Fans or fan systems that were automatically shut down by the fire alarm control unit or device in Class ‘E’, ‘J’ and ‘C’ systems shall be manually enabled to start by a means of overriding the fan shutdown through use of a city-wide standard key switch (#2642) located at the Fire Command Station. The actual start of the fan(s) shall be accomplished manually through HVAC controls at the Fire Command Station, or at the Mechanical Control Center or locally at the fan room(s).

Add Section 3-9.3.6 as follows:

Section 3-9.3.6 – Smoke exhaust control means shall be enabled through the use of a city-wide standard key (#2462) located at the Fire Command Station or fire alarm control unit, or when neither is provided, in the entrance lobby of the building.

Section 3-10.4 - Delete

Section 3-11 - Delete in its entirety.

Section 3-12.3 - Delete in its entirety.

Section 3-12.4.1 - Delete the exception.

Section 3-12.4.2 - Delete

Section 3-12.4.3.1 - Delete

Section 3-12.4.3.2 - Delete

Section 3-12.4.4 - Delete

Section 3-12.4.5.1 - Delete the third sentence starting from "The fire command station shall be permitted . . ."

Section 3-12.4.6.2 B Delete

Section 3-12.4.6.3 - Delete

Section 3-12.5.1-Delete

Section 3-12.6.6 B Delete

Section 3-12.6.7 - Delete

CHAPTER 4

Deleted in its entirety (this chapter is for fire alarm central offices, which falls under the Fire Department's jurisdiction).

CHAPTER 5 - INITIATING DEVICES

Section 5-1.3.4 - Delete "*appropriate NFPA standard or*" from the first sentence.

Section 5-1.3.5 - Delete

Section 5-2.2 - Delete "*either by the appropriate NFPA standard or*" from the sentence.

Section 5-3.2- Delete "*either by the appropriate NFPA standard or*" from the sentence.

Section 5-3.5.9 - Add, "*Where required by the authority having jurisdiction*" at the beginning of the paragraph.

Section 5-3.6.2 - Add, "*Where required by the authority having jurisdiction*" at the beginning of the paragraph.

Section 5-5.2 - Delete "*either by the appropriate NFPA standard or*" from the paragraph.

Section 5-6.1 - Delete "*either by the appropriate NFPA standard or*" from the second sentence.

Section 5-8.1 - Substitute the words "*approvals/acceptances*" for "*listings*".

Add Section 5-8.2 to read as follows:

Section 5-8.2 – Appropriate means may involve:

(a) Foam Systems: Flow of Water

(b) Pump Activation

(c) Differential Pressure Detector

(d) Halon: Pressure Detector

(e) Carbon Dioxide: Pressure Detector

In any case, an alarm that activates the extinguishing system may be initiated from the detection system.

Section 5-9.1.1 - Change the second sentence to read as follows: "*The operable part of each manual fire alarm box shall be 4 feet above finished floor level.*"

Section 5-9.1.2 - Delete

Section 5-9.1.3 - Change the number of repetitions produced from three to four.

Sections 5-9.2 to 5-9.2.11 - Delete

Sections 5-9.2.12 to 5-9.2.12.6 - Delete

Sections 5-9.2.13 to 5-9.2.14.2 - Delete

Section 5-10.5 – Delete and substitute the following:

Section 5-10.5 – Room Temperature Supervisory Signal-Initiating. B When temperature supervisory devices are provided to indicate a low temperature condition, they shall indicate the decrease in room temperature to 40° F (4.4° C) and its restoration to above 40° F (4.4° C).

Section 5-11.4.2 - Delete "*NFPA 90A, Standard for the installation of Air Conditioning and Ventilating Systems*" and substitute with "*Reference Standard RS 13-1.*"

Section 5-11.5.2.1 - Delete "*other NFPA standards*" and substitute with "*Reference Standard RS 13-1.*"

Figure 5-11.7.4.1.1.(D) to read "*One detector mounted on the higher side*"

Reference Standard 17

CHAPTER 6 - NOTIFICATION APPLIANCES FOR FIRE ALARM SYSTEMS

Section 6-3.7 – Amend to read as follows:

Section 6-3.7 – Location of Audible Signal Appliances. Where ceiling heights permit, wall mounted appliances shall have their [tops] centerline at heights above the finished floors of [not less than 90 in. (2.30m)] 8 ft. (2.45m) and [below the finished ceilings of not less than 6 in. (0.15 m)] where ceiling heights prevent installation at this height installation shall be not greater than 6 in. (0.15m) below. This shall not preclude ceiling-mounted or recessed appliances.

Exception: Combination audible/visible appliances [installed in sleeping areas shall comply with 6-4.4.3].

Section 6-4.2 - Delete

Section 6-4.4 is modified to read as follows:

Section 6-4.4 Appliance Location. – Wall-mounted appliances shall have their bottoms at heights above the finished floor of no less than 80 in. (2-m) nor less than 6 in. (13.5 cm) below the ceiling, whichever is lower. [and no greater than 96 in. (2.4 m).] Ceiling-mounted appliances [shall] may be installed [per Table 6-4.4.1(b)].

Exception: Appliances installed in sleeping areas shall comply with 6-4.4.3.

Figure 6-4.4.1 - Delete

Section 6-4.4.1.1 is modified to read as follows:

Section 6-4.4.1.1 – Spacing shall be in accordance with [Figure 6-4.4.1 and] Table[s] 6-4.4.1(a) [and (b)]. A maximum separation between appliances shall not exceed 100-ft. (30 m). Visible notification appliances shall be installed in accordance with Table 6-4.4.1 (a), using one of the following:

(a) A single visible notification appliance, or

(b) Two visible notification appliances located on opposite walls, or

(c) In rooms 80 ft. by 80 ft. or greater, where there are more than two appliances in

any field of view, they shall be spaced a minimum of 55 ft. from each other, or

(d) More than two visible notification appliances that flash in synchronization.

Section 6-4.4.2.1 is modified to read as follows:

Table 6-4.4.2 applies to corridors not exceeding 20 ft. (6.1 m) wide. For corridors greater than 20 ft. (6.1 m) wide, refer to [Figure 6-4.4.1 and] Table[s] 6-4.4.1(a) [and (b)]. In a corridor application, visible appliances shall be UL 1971 rated not less than 15 cd, and shall have an on-axis intensity of not less than 75 cd.

Table 6-4.4.1 (a) is modified as follows:

Table 6-4.4.1(a) Room Spacing Allocation for Wall-Mounted Visible Appliances Minimum Required Light Output, Candela (cd) (Effective Intensity) (see note below)

| Maximum Room Size | One Light Per Room(cd) | Two Lights per Room (Located on Opposite Walls) (cd) | Four Lights per Room - One Light per Wall (cd) |
|-------------------|------------------------|--|--|
| 20' x 20' | 15 | N/A | N/A |
| 30' x 30' | 30 | 15 | N/A |
| 40' x 40' | 60 | 30 | [15] N/A |
| 45' x 45' | 75 | 60 | N/A |
| 50' x 50' | 95 | 60 | [30] N/A |
| 55' x 55' | 110 | 75 | N/A |
| 60' x 60' | 135 | 95 | [30] N/A |
| 70' x 70' | 185 | 110 | [60] N/A |
| 80' x 80' | 240 | 140 | 60 |
| 90' x 90' | 305 | 180 | 95 |
| 100' x 100' | 325 | 240 | 95 |
| 110' x 110' | 455 | 240 | 135 |
| 120' x 120' | 540 | 305 | 160 |
| 130' x 130' | 635 | 375 | 185 |

NOTE: *Candela (cd) ratings, as indicated, are based on UL 1971 listings. On-axis ratings shall in no case be less than 75 cd.*

Table 6.4.4.1(b) - Delete

Section 6-6 - Delete

Section 6-6.1 - Delete

Section 6-6.2 - Delete

Section 6-8 - Delete in its entirety.

Section 6-9 - Delete in its entirety.

CHAPTER 7

Section 7-1.1.1 is modified to read as follows:

Section 7-1.1.1 – Inspection, testing and maintenance programs shall satisfy the requirements of [this code] the Fire Commissioner, the New York City Building Code and the equipment manufacturer's instructions.

Reference Standard 17

Section 7-1.2 - Delete the second sentence starting from "Delegation."

Section 7-1.2.1 - Delete

Section 7-1.2.2 - Delete and enact three new sections as follows:

Section 7-1.2.2 – Personnel shall be qualified and experienced in the inspection and testing of fire alarm systems and shall meet the following requirements:

(a) Certified by the Buildings and/or Fire Commissioners, or

(b) Trained and qualified personnel of a NYC licensed electrical contracting firm, or

(c) Personnel with National Institute for Certification in Engineering Technologies (NICET) Certification of Level II in fire alarm technology, or

(d) Trained and qualified personnel of firm listed by a national testing laboratory for servicing of fire alarm systems.

Section 7-1.2.3 – Personnel shall be qualified and experienced in the maintenance of fire alarm systems and shall meet the following requirements:

(a) Factory trained and certified, or

(b) Trained and qualified personnel of NYC licensed electrical contracting firm, or

(c) Trained and qualified personnel of firm listed by a national testing laboratory for servicing of fire alarm systems.

(d) Service personnel employed pursuant to (a), (b), and (c) above shall either have a valid NICET Certification of Level II in fire alarm technology or work under the direct supervision of a person having such certification.

Exception: The following are exempt from the above requirements:

(1) Person(s) exclusively performing smoke detector cleaning, having a Certificate of Fitness from the Fire Department and working under the supervision of, or employed by a person(s) having NICET Level II certification.

(2) Person(s) exclusively performing maintenance of fire alarm systems installed and approved prior to 1987, and working under the supervision of, or employed by a person(s) having NICET Level II certification.

(e) If during the course of maintenance either:

(1) total system replacement, or

(2) wiring repair, or

(3) replacement of wiring is (are) indicated, such repair(s) or replacement(s) shall be performed by a person holding a license or a special license in accordance with the provisions of the NYC Electrical Code.

Section 7-1.4 is modified to read as follows:

Section 7-1.4 – Prior to system maintenance or testing, [the system certificate and the] all information regarding the system and Y to the service personnel.

Section 7-1.5.1 - Delete and substitute the following:

Section 7-1.5.1 – The special hazard system and main building system shall be tested concurrently.

Section 7-1.6 B Amend the last sentence to read as follows:

In addition, except for Class "E", "J" and "C" systems, 10 percent of initiating devices that are not directly affected by the change, up to a maximum of 50 devices, shall also be tested and proper system operation verified.

Section 7-2.1 B Delete

Section 7-2.2 – Delete and substitute the following:

Section 7-2.2 – Testing, which involves the disconnection of circuits of 50 volts or more with the exception of audio circuits up to 75 volts, shall be performed in accordance with the New York City Electrical Code by licensed electrical contracting firms meeting the requirements of Sections 7-1.2.3 and 7-1.2.3.1.

Sections 7-3.1 to 7.3.1.2 - Delete

Section 7-3.2 shall be deleted and substitute the following:

Section 7-3.2 Testing – Testing shall be performed in accordance with the requirements of the Fire Prevention Code.

Sections 7-3.2.1 to 7-3.4 - Delete

Section 7-4.1 shall be deleted and substitute the following:

Section 7-4.1 – Fire alarm system equipment shall be periodically maintained in accordance with manufacturers' instructions and the Fire Prevention Code.

Sections 7-4.2 to 7-4.4 - Delete

Sections 7-4.4.1 to 7-4.4.3.2 - Delete

Section 7-5.1 - Delete

Sections 7-5.3 to 7-5.4 - Delete

CHAPTER 8 - REFERENCED PUBLICATIONS

Delete in its entirety.

APPENDIX A - EXPLANATORY MATERIAL

This appendix is not part of Reference Standard RS 17-5, but is included for information purposes only with the exception of the following:

Section A-6-4.4.1 - Delete in its entirety and substitute the following:

Section A-6-4.4.1 – A design which delivers 0.0375 lumens per sq. ft. effective intensity to all occupied spaces where visible notification is required, is considered to meet minimum light intensity requirements of this section. The field of view is based on the focusing capability of the human eye, specified as 120 degrees in the IES Handbook. The apex of this angle is the viewer's eye. In order to ensure compliance with the requirements of Section 6-4.4.1, it has been accepted that this angle be increased to approximately 135 degrees.

Figure A-6-4.4.1 (a) - Delete

Figure A-6-4.4.1 (b) - Delete

Figure A-6-4.4.1 (c) - Delete

Figure A-6-4.4.1 (d) - Delete

Figure A-6-4.4.2 - Delete

APPENDIX B - ENGINEERING GUIDE FOR AUTOMATIC FIRE DETECTOR SPACING

This appendix is not part of Reference Standard RS 17-5, but is included for information purposes only.

**** DOB 1-9-02; 310-90 BCR**

*** REFERENCE STANDARD 17-5A**

Repealed

***310-90 BCR; 1014-80 BCR**

Reference Standard 17

*REFERENCE STANDARD RS 17-5B

Repealed

*310-90 BCR; 1014-80 BCR

†REFERENCE STANDARD RS 17-5C

Repealed

†310-90-BCR; 633-83 BCR

*REFERENCE STANDARD RS 17-5D

Repealed

*310-90 BCR; 1014-80 BCR

*REFERENCE STANDARD RS 17-5E

ANSI/NFiPA No. 72E-1990-Standard for Automatic Fire Detectors.

*310-90 BCR; 1014-80 BCR

*REFERENCE STANDARD RS 17-6

ANSI B16.4-1985-Cast-Iron Threaded Fittings, Class 125 and 250.

*310-90 BCR; 1014-80 BCR

**REFERENCE STANDARD RS 17-6A

Valves and Related Products for Fire Protection Service.

UL193-1988-Alarm Valves for Fire-Protection Service (Revision 9/88).

UL260-1988-Dry Pipe and Deluge Valves for Fire-Protection Service.

UL262-1988-Gate Valves for Fire-Protection Service.

UL312-1988-Gate Valves for Fire-Protection Service (Revision 10/89).

***UL668-1988-Hose Valves for Fire-Protection Service.

UL753-1989-Alarm Accessories for Automatic Water Supply Control Valves For Fire-Protection Service (Revision 8/89).

UL789-1987-Indicator Posts for Fire-Protection Service (Revision 3/89).

UL1091-1986-Butterfly Valves for Fire-Protection Service.

UL1468-1985-Direct-Acting Pressure-Reducing and Pressure-Control Valves for Fire-Protection Service.

UL 1486-1979-Quick Opening Devices for Dry Pipe Valves for Fire-Protection Service (Revision 7/85).

UL1726-1985-Automatic Drain Valves for Standpipe Systems (Revision 9/88).

UL1739-1988-Pilot-Operated Pressure Control Valves for Fire-Protection Service.

**310-90 BCR

***As enacted but "UL668-1989" probably intended.

**REFERENCE STANDARD RS 17-7

ANSI/AWWA C110-1987-Ductile-Iron and Grey-Iron Fittings, 3-Inch through 48-Inch for Water and Other Liquids.

**310-90 BCR; 1014-80 BCR

†REFERENCE STANDARD RS 17-8

ANSI/††ASTM C111-1985-Rubber-Gasket Joints for Ductile-Iron and Grey-Iron Pressure Pipe and Fittings.

†310-90 BCR; 633-83 BCR

†† As enacted but "AWWA" probably intended.

†REFERENCE STANDARD RS 17-9

ANSI/ASTM A234-1988b-Specification for Pipe Fittings for Wrought Carbon Steel and Alloy Steel for Moderate and Elevated Temperatures.

†310-90 BCR; 633-83 BCR

†REFERENCE STANDARD RS 17-10

ANSI/NFiPA No. 22-1987-Standard for Water Tanks for Private Fire Protection.

†310-90 BCR; 633-83 BCR

†REFERENCE STANDARD RS 17-11

UL No. 217-1985-Single and Multiple Station Smoke Detectors including Revision of February †††19, 1989.

†310-90 BCR; 633-83 BCR

†††As enacted but "27," probably intended.

***REFERENCE STANDARD RS 17-12

ANSI/NFiPA No. 74-1989-Standard for the Installation, Maintenance and Use of Household Fire Warning Equipment, as Modified. The following Sections of this standard are modified to read as follows:

1-1 Scope. Covers the requirements for the proper selection, installation, operation and maintenance of fire warning equipment for use within dwelling units or rooming units.

1.2.6 The installation of wiring and equipment shall be in accordance with the New York City Electrical Code.

2-1.1.1 Smoke detectors shall be installed outside of each separate sleeping area in the immediate vicinity of the bedrooms in dwelling units, in Occupancy Groups J-2 and J-3, and in Basements and Basement Recreation Rooms in Occupancy Group J-3.

Smoke detectors shall be installed within the sleeping area of hotel or motel units, rooming units or studio dwelling units in Occupancy Group J-1.

4-5.5 Each smoke detector shall have an integral test means to permit the occupant to check that it is operational. A continuous power display indicator light is recommended.

4-2.1.4 A smoke detector installed to protect a sleeping area in accordance with 2-1.1.1, shall be located outside the bedroom but in the immediate vicinity of the sleeping area, except as set forth for rooming units.

5-2.1.6 Smoke detectors shall be located on or near the ceiling, and within fifteen feet of all rooms used for sleeping purposes in J-2 or J-3 occupancies. In all dwelling units, with multiple levels, when any level has only one means of egress, the dwelling unit shall be provided with smoke detectors on all levels.

5-2.1.6.1 If ceiling mounted, the closest edge of the detector shall be a minimum of four inches from any wall.

5-2.1.6.2 If wall mounted, the closest edge of the detector shall be a minimum of four inches and a maximum of twelve inches from the ceiling.

***310-90 BCR; 798-81 BCR

Reference Standard 17

†† Reference Standard 17-13

UL No. 2034, Standard for Single and Multiple Station Carbon Monoxide Detectors, October 29, 1996, with revisions through June 28, 2002.

††*DOB 10-26-04*

†† Reference Standard 17-14

NFPA No. 720, Recommended Practice for the Installation of Household Carbon Monoxide (CO) Warning Equipment, 2003 Edition, as modified. The following sections of this standard are modified to read as follows (deleted text is in brackets; new text is italicized):

Title on page 720-4: “NFPA 720 Recommended Practice for the Installation of [Household] Carbon Monoxide (CO) Warning Equipment, 2003 Edition”

1.1.2 This document is limited to carbon monoxide warning equipment for use in *J-1, J-2, J-3, G and H-2 occupancies* [family living units] that contain fuel-burning *equipment*, appliances or fireplaces or have attached garages.

1.1.3 This document contains recommendations for the selection, installation, operation, and maintenance of equipment that detects concentrations of carbon monoxide that could pose a risk to the health of most occupants [in family living units].

2.3.1 UL Publication. Underwriters Laboratories, Inc., 333 Pfingsten Road, Northbrook, IL 60062. UL 2034. Standard for Single and Multiple Station Carbon Monoxide Detectors, October 29, 1996, *as revised through June 28, 2002*.

3.2.2* Authority Having Jurisdiction (AHJ). *The New York City Department of Buildings, New York City Fire Department, New York City Department of Housing Preservation and Development, and New York City Department of Health and Mental Hygiene*. [The organization, office, or individual responsible for approving equipment, materials, an installation, or a procedure.]

3.3.3 *Dwelling* [Family Living] Unit. *One or more rooms in a building occupied in whole or in part as the temporary or permanent home or residence of one or more families, where such room or rooms are arranged, designed, used or intended for use by one or more families, including such units in occupancy groups J-1 (hotels, motels, lodging houses, rooming houses, etc.), J-2 (apartment houses, apartment hotels, school dormitory buildings, etc.), and J-3 (one- and two-family dwellings, rectories, convents, group homes, etc.)*. [One or more rooms in a single family detached dwelling, single family attached dwelling, multifamily dwelling, or mobile home for the use of one or more persons as a housekeeping unit with space for eating, living, and sleeping and permanent provisions for cooking and sanitation.]

3.3.9 Separate Sleeping Area. The area of a *dwelling* [family living unit] where the bedrooms or sleeping rooms are located.

3.3.10.1 Alarm Signal. A signal indicating a concentration of carbon monoxide that could pose a risk to the life safety of the occupants [in the family dwelling unit] and requiring immediate attention.

4.2 Supplemental Functions. Supplemental functions, including the transmission of an alarm beyond the *premises* [household] should be permitted and should not interfere with the performance recommendations of this document.

4.3 Total System. Where the AHJ requires both the alarm and transmission beyond the *premises* [household] and the total system to comply with the applicable sections of [NFPA 72, National Fire Alarm Code] *RS 17-3, 17-3A, or 17-3B*, the recommendation of Section 5.1 and 5.4.2 of this document *shall* [should] be followed. Title of Chapter 5: Chapter 5 [Household] Carbon Monoxide Warning Equipment

5.1 *Required* [Recommended] Protection.

5.1.1.1 A carbon monoxide detecting alarm or detector *shall* [should] be centrally located *as provided for in § 5.1.2 and 1 R.C.N.Y. § 28-02* [outside of each sleeping area in the immediate vicinity of the bedrooms].

5.1.1.3 Each alarm or detector *shall* [should] be located on the wall, ceiling, or other location as specified in the installation instructions accompanying the unit. *To help prevent false alarms, such alarm or detector should be located away from sources of humidity such as bathrooms and should be located away from a range or other fossil fuel burning equipment. To prevent damage by occupants, such alarm or detector should be located out of reach of children and pets.*

5.1.2 Alarm notification appliances. Each alarm or detector *shall* [should] cause the operation of an alarm notification appliance that *shall* [should] be clearly audible in all bedrooms over background noise with all intervening doors closed, *in accordance with Annex A, § A.5.1.1.1*.

5.2.1.1 All power supplies *shall* [should] have sufficient capacity to operate the signal(s) for at least 12 continuous hours.

5.2.1.2 For electrically powered household carbon monoxide warning equipment, the primary (main) power source *shall* [should] be ac, unless otherwise permitted by the following:

(1) Detectors and alarms are permitted to be powered by a monitored dc circuit of a control unit when power for the control unit meets the recommendations of section 5.2 and the circuit remains operable upon the loss of primary (main) ac power.

(2) A detector and a wireless transmitter that serves only that detector are permitted to be powered from a monitored batter (main) source where part of a listed, monitored, low-power radio (wireless) system.

[(3) In existing construction, a monitored battery primary (main) power source, as described in 5.2.3, is permitted.]

5.2.2.1 An ac primary (main) power source *shall* [should] be a commercial light and power supply or other dependable source *and shall be provided with a secondary (standby) power supply complying with § 5.2.4*.

5.2.2.2 A visible “power on” indicator *shall* [should] be provided.

Reference Standard 17

5.2.2.3 Primary (main) ac power *shall* [should] be supplied from either a dedicated branch circuit or the unswitched portion of a branch circuit also used for power and lighting.

5.2.2.4 All electrical systems *shall comply with the New York City Electrical Code* [designed to be installed by other than a qualified electrician should be powered from a source not in excess of 30 volts that meets the requirements for Class 2 circuits as defined in Article 725 of NFPA 70, National Electrical Code®].

5.2.2.7 The recommendation of 5.2.2.6 does not apply *in J-1, J-2, and J-3 occupancies* where a ground fault circuit interrupter serves all electrical circuits within the household.

5.2.2.9 [Where a secondary (standby) battery is provided, the] *The* primary (main) power supply should be of sufficient capacity to operate the system under all conditions of loading with *the* [any] secondary (standby) battery disconnected or fully discharged.

5.2.3 Primary Power Supply – Monitored Battery. [Household] [c]Carbon monoxide warning equipment *may* [should] be [permitted to be] powered by a battery *only where permitted by 1 R.C.N.Y. 28-02 and*,] provided that the battery is monitored to ensure that the following conditions are met:

- (1) All power recommendations are met for at least one year of battery life, including monthly testing.
- (2) A distinctive audible trouble signal sounds before the battery is incapable of operating the device(s) (from causes such as aging or terminal corrosion) for alarm purposes.
- (3) Automatic transfer is proved from alarm to a trouble condition for a unit employing a lock-in alarm feature.
- (4) The unit is capable of producing an alarm signal for at least 12 hours at the battery voltage at which a trouble signal is normally obtained, followed by not less than 7 days of trouble signal operation.
- (5) After the initial 4 minutes of alarm, the 5-second “off” time of the alarm signal should be permitted to be changed to 60 seconds \pm 10 percent.

5.2.4.1 When provided, a secondary (standby) power supply *shall* [should] have sufficient capacity to power the unit for 8 hours, followed by not less than 12 hours of alarm, followed by not less than 7 consecutive days of trouble signals.

5.2.4.2 After the initial 4 minutes of alarm, the 5-second “off” time of the alarm signal *shall* [should] be permitted to be changed to 60 seconds \pm 10 percent.

5.2.4.3 Removal or disconnection of a battery used as a secondary (standby) power source *shall* [should] cause [an] audible [or] *and* visible trouble signals.

The word *should* which indicates recommendation shall be replaced with the word *shall* which indicates mandated compliance in the following sections:

5.2.4.6

5.3.1.3

5.3.2.1 through 5.3.2.4

5.3.3.1

5.3.4.1 and 5.3.4.2

5.3.5.1 through 5.3.5.3

5.3.6.1 through 5.3.6.4

5.3.6.5 Each electrical carbon monoxide system *shall* [should] have an integral test means to allow the *occupants* [householder] to test the system operation.

The word *should* which indicates recommendation shall be replaced with the word *shall* which indicates mandated compliance in the following sections:

5.3.7.1 and 5.3.7.2

5.3.8.1 Where carbon monoxide alarms or detectors are interconnected to fire alarm or combination control units, connections *shall* [should] be via *alarm* [supervisory] circuits only, *and all alarms and/or detectors and control units shall be certified as compatible by the manufacturer(s) and shall be approved by the Materials Equipment Acceptance Division of the Department of Buildings.*

The word *should* which indicates recommendation shall be replaced with the word *shall* which indicates mandated compliance in the following sections:

5.3.8.2 and 5.3.8.3

5.3.9.1 Supervising station systems requiring transmission of signals to continually staffed locations providing supervising station services (for example, central station service, proprietary stations, or remote stations) *shall* [should] also comply with the applicable requirements of [Chapter 8 of NFPA 72®, National Fire Alarm Code.®] *3 R.C.N.Y 17-01, Rules of the Fire Department of New York.*

5.3.9.2 Where carbon monoxide alarms, detectors, multipurpose detectors, or combination or multiple station alarms or systems are connected to supervising station fire alarm systems, receipt of alarm signals *shall* [should] be distinctively indicated as “*alarm* [supervisory] signal carbon monoxide” or other non-fire alarm signal designation acceptable to the AHJ.

5.3.9.3 Signals received by the supervising station *shall* [should] be processed by the supervising station personnel in accordance with the *rules of the Fire Department of New York.* [following recommendations:

(1) They should retransmit the supervisory signal to public fire service communications center.

(2) They should notify the subscriber by the quickest available method.

(3) When the signal results from a pre-arranged test, action recommended by 5.3.9.3 (1) and (2) is not necessary.]

5.3.10.1 Carbon monoxide warning systems utilizing low-power wireless transmission of signals within the protected [household should] *premises shall* comply with the *applicable* requirements of [NFPA 72®, National Fire Alarm Code®] *RS 17-3, 17-3A, or 17-3B, and must be approved by the Material Equipment Acceptance Division (MEA).*

The word *should* which indicates recommendation shall be replaced with the word *shall* which indicates mandated compliance in the following sections:

5.4.1.1 through 5.4.1.6

5.6.1 through 5.6.3

††DOB 10-26-04



**REFERENCE STANDARD RS-18
ELEVATORS AND CONVEYORS**

***LIST OF REFERENCED NATIONAL STANDARDS**

| | | |
|-------------------|--|------|
| ANSI/ASME A17.1 | Safety Code for Elevators and Escalators and Supplements A17.1a-1997 as Modified..... | 1996 |
| ANSI A117.1 | American National Standard for Buildings and Facilities Providing Accessibility and Usability for Physically Handicapped People as Modified..... | 1986 |
| ANSI B153.1 | Safety Requirements for the Construction, Care and Use of Automobile Lifts..... | 1981 |
| | FS00-L-360D Motor Vehicle Lifts..... | 1987 |
| ANSI/ASME MH14.1 | Loading Dock Levelers and Dockboards..... | 1987 |
| ANSI/ASME B20.1 | Safety Standards for Conveyors and Related Equipment..... | 1987 |
| ANSI A10.4 | Safety Requirements for Personal Hoists..... | 1981 |
| ANSI/ASME A90.1 | Safety Standard for Belt Manlifts..... | 1985 |
| ANSI B77.1 | Safety Requirements for Aerial Passenger Tramways and Supplements B77.1a-86 and B77.1b-88..... | 1982 |
| ANSI/ASTM F698 | Standard Specification for Physical Information to be Provided for Amusement Rides and Devices as modified..... | 1988 |
| ** ASNT/SNT-TC-1A | American Society for Nondestructive Testing Certification/ Qualification Recommended Practice in NDT..... | 1992 |
| ** ASTM 3.03 | Standards for Non-destructive Testing | 1995 |
| ** ASTM F770 | Practice for Operation Procedures for Amusement Rides and Devices..... | 1988 |
| ** ASTM F846 | Guide for Testing Performance of Amusement Rides and Devices | 1992 |
| ** ASTM F853 | Practice for Maintenance Procedures for Amusement and Devices..... | 1991 |

*DOB 1-16-03; 5-22-95; 11-91 BCR; 678-85 BCR; 98-83 BCR

**DOB 3-8-96

† REFERENCE STANDARD RS 18-1

ANSI/ASME A17.1-1996 Safety Code for Elevators and Escalators and Supplement A17.1a-1997 as Modified.

Wherever in such Code reference is made to the National Electrical Code ANSI/NFPA NO. 70, substitute New York City Electrical code, Rules and Regulations of the Bureau of Electrical Control of the Department of Buildings and its Advisory Board

Wherever in such Code reference is made to the local Building Code, or model building code, substitute New York City Building Code.

Wherever in such Code reference is made to ASME A17.3, Safety Code for Existing Elevators and Escalators, substitute Article 2 of Subchapter 18 of such chapter.

Modifications.- The provisions of ANSI/ASME A17.1-1996 and Supplement A17.1a-1997 shall be subject to the following modifications. The section numbers are from that standard.

§1. Add or amend the following definitions to

Introduction-Section 3 - Definitions:

(i) Amend the definition designated level to read as follows:
Designated level.-The [main] street floor or other level that best serves the needs of emergency personnel for fire fighting or rescue purposes (applicable to Rule 211.3).

(ii) Add the definition elevator classification between elevator and freight elevator to read as follows:

Elevator Classification.- Elevator is classified as freight or passenger.

(iii) Add the definition elevator, service car between elevator, rooftop and elevator, shipboard to read as follows:

Elevator, Service Car.- A passenger or freight elevator located in an Interim Multiple Dwelling registered with the Loft Board, in accordance with Article 7-C of the Multiple Dwelling Law.

(iv) Add the definition hospital emergency service between hoistway gate and hydraulic elevator to read as follows:

Hospital Emergency Service.- A special operating control function that may be provided for elevators in a building classified in occupancy group H-2 (Hospital) or other applicable medical facility used to transport patient in a life or death situation.

(v) Amend subdivisions a and b of the definition “installation placed out of service” to read as follows:

Installation placed out of service.- An installation whose power feed lines have been disconnected from the mainline disconnect switch and;

(a) an electric elevator, dumbwaiter, sidewalk elevator or material lift whose suspension ropes have been removed, whose car and counterweight rest at the bottom of the hoistway, and whose hoistway doors have been permanently barricaded or sealed in the closed position on the hoistway side;

(b) a hydraulic elevator, dumbwaiter, sidewalk elevator or material lift whose car rests at the bottom of the hoistway; whose pressure piping has been disassembled and a section removed from the premises; whose hoistway doors have been permanently barricaded or sealed in the closed position on the hoistway side; suspension ropes removed and

Reference Standard 18

counterweights, if provided, landed at the bottom of the hoistway (c) an escalator or moving walk whose entrances have been permanently barricaded.

(vi) Add the definition patient elevator between passenger elevator and penetrate a floor to read as follows:

Patient Elevator.- An elevator located in a building classified in occupancy group H-2 (hospital) reserved for the “sole” use of vertical transportation of non-ambulatory patients who are incapable of self-preservation because of age, physical or mental disability. Hospital staff or other passengers transporting patient are permitted to ride with the patient. Such elevators must be operated by a designated attendant and shall meet the requirements of rules 211.4 and 211.5(c) of this reference standard.

(vii) Add the definition platform guard (toe guard or apron) between pit elevator and plunger (ram) to read as follows:

Platform Guard (Toe Guard or Apron).- A section of sheet metal the full width of the door opening, securely attached to the car sill and extending downward, protecting the landing zone.

(viii) Delete the definition of private residence and substitute the following:

Private Residence.- A building in occupancy group J-3 except group home as defined in Section 27-266 of article eleven of subchapter three of this chapter.

(ix) Add the definition sky lobby between skirt, escalator and slack-rope switch to read as follows:

Sky Lobby.- The lowest landing of an elevator or a group of elevators located above the street level.

(x) Add the definition smoke hole between slope, moving walk and solid state device to read as follows:

Smoke Hole.- An opening for an elevator hoistway venting in the elevator machine room floor at the top of the elevator hoistway(s).

(xi) Add the definition zero clearance vestibule after yield strength to read as follows:

Zero Clearance Vestibule.- A space on the elevator lobby between the exterior of hoistway door and the security door attached to the elevator hoistway.

§2 Delete and replace subdivision d of rule 100.1 to read as follows:

100.1d Multiple Hoistways.

(1) Not more than three (3) elevators shall be located in buildings with a single hoistway.

(2) Not more than four (4) elevators shall be located in a single hoistway in buildings with more than one (1) hoistway.

(3) Low rise, mid rise and high rise elevators shall be located in separate hoistways.

§3 Amend sub division d of rule 100.3 to read as follows:

100.3d Construction of Floors.- Floors [may] shall be either of concrete, or [may be] of metal construction [with or] without perforations. [Metal floors shall conform to the following:

(1) If of bar-type grating, the openings between bars shall reject a ball $\frac{3}{4}$ in. (19mm) in diameter.

(2) If of perforated sheet metal or of fabricated openwork construction, the openings shall reject a ball 1 in. (25mm) in diameter.]

§4. Delete and replace rule 100.4 to read as follows:

Rule 100.4 Control of Smoke and Hot Gases.

Hoistways of elevators shall be provided with means to prevent the accumulation of smoke and hot gases in case of fire by any one of the following:

100.4a Vents in the hoistway enclosures.

(1) Location of Vents:

(a) In the side of the hoistway enclosure below the elevator machine room floor or in the roof of the hoistway, and shall be open either directly to the outer air or through non-combustible ducts to the outer air.

(b) In the wall or roof of an overhead elevator machine room through the smoke hole in the top of the elevator hoistway and shall be vented to the outer air through non-combustible ducts.

(2) Area of Vents.- The area of vents in hoistway or elevator machine room and area of smoke hole shall be not less than three and one-half (3½) percent of the area of the hoistway nor less than three (3) square feet for each elevator car, whichever is greater, with the following vent types:

(a) Open Vents.- of the total required vent area, not less than one-third ($\frac{1}{3}$) shall be permanently open or with openable hinged damper. Smoke hole shall be permanently open.

(b) Closed Vents.- The two-third ($\frac{2}{3}$) closed portion of the required vent area either in the hoistway enclosure or in the elevator machine room may consist of windows or skylights glazed with plain glass not more than one-eighth ($\frac{1}{8}$) inch thick. A closed damper that will open upon the activation of a smoke detector placed at the top of the hoistway shall be considered closed vents.

100.4b Mechanical ventilation of the hoistway enclosure.- In all elevator and dumbwaiter hoistways where the venting of elevator and dumbwaiter hoistway is by mechanical means, there shall be provided a system of a mechanical ventilation of sufficient capacity to exhaust at least twelve (12) air changes per hour of the volume of such hoistways through a roof or an approved location on an exterior wall other than the lot line wall, and shall be subject to the following:

(1) The smoke detector shall be placed at the top of these hoistways to activate mechanical ventilation system.

(2) A mechanical ventilation system serving these hoistways shall not pass through the overnight sleeping areas of hotel, apartment house, hospital, or similar building.

(3) A manual control to shut down the mechanical ventilation system shall be provided in or near the elevator control panel at the designated level.

100.4c Air pressurization of hoistway enclosure.- where air pressurization of the hoistway is utilized as a means of smoke and hot gas control, the air shall not be introduced into the hoistway in such a manner as to cause erratic operation by impingement on landing or car door equipment, traveling cables, selector tapes, governor

Reference Standard 18

ropes, compensating ropes, and other components sensitive to excess movement or deflection.

100.4d The Commissioner may accept alternate means to prevent the accumulation of smoke and hot gases in the hoistways of elevators in case of fire.

§5. Amend first paragraph of rule 100.5 to read as follows:

Rule 100.5 Windows and Skylights.

Windows in the walls and skylights at the top of hoistway enclosures are prohibited.

§6 Add subparagraph e to paragraph 1 of subdivision d of rule 101.3 to read as follows:

e. Machine room doors shall be labeled “ELEVATOR MACHINE ROOM” with letters not less than two (2) inches (51 mm) high.

§7 Amend subdivision a of rule 101.5 to read as follows:

101.5a control switch shall be located on the lock-jamb side of the access door.

§8. Amend subdivision c of rule 101.5 to read as follows:

101.5c Receptacle.- A duplex receptacle rated at not less than 15A, 120V with ground fault interrupt shall be provided in each machine room and machinery space.

§9. Amend the second paragraph of rule 102.1 to read as follows:

Rule 102.1 Installation of Electrical Equipment and Wiring In Hoistways and Machine Rooms.

Only such electrical wiring, raceways, and cables used directly in connection with the elevator, including wiring for signs, for communication with the car, for lighting, heating, air conditioning, and ventilating the car, for fire detecting systems, for pit sump pumps, and for heating and lighting the hoistway and/or the machine room and electrical wiring permitted by article one of subchapter eighteen of chapter 1 of title 27 of the administrative code, may be installed inside the hoistway and/or the machine room.

§10. Amend rule 103.1 to read as follows:

Rule 103.1 Location of Counterweights.

Counterweights shall be located in the hoistway of the elevator that they serve [or in a remote hoistway, subject to the limitations and requirements of Rule 103.3].

§11. Amend the title of rule 103.3 to read as follows:

Rule 103.3 Existing Remote Counterweight Hoistways.

§12. Add new paragraph 5 to subdivision b of rule 106.1 to read as follows:

(5) Walk-in pits with floors located at the same elevation as the adjacent floor, access landing will not require separate drainage or sump pumps.

§13. Amend paragraph 1 of subdivision d of rule 106.1 to read as follows:

(1) Access shall be by means of the lowest hoistway door or by means of a separate access door located at the level of pit floor.

§14. Add new subparagraphs d and e to paragraph 4 of such subdivision of such rule to read as follows:

(d) If at any point of travel including the car under full compressed buffer, any equipment attached to the car extends within the hoistway space in the pit, the pit door shall be equipped with door electric contact which shall cause the electric power to be removed from the elevator

driving-machine motor and brake.

(e) If the door electric contact is installed a sign “WARNING- Opening of the Pit Door will Stop Elevator” is attached on the outside of the door.

§15. Amend paragraph 4 of subdivision e of rule 106.1 to read as follows:

(4) A GFI duplex receptacle rated at not less than 15A, 120V shall be provided.

§16. Amend the first paragraph of rule 110.1 to read as follows:

Rule 110.1 Entrances and Emergency Doors Required

All elevator hoistway-landing openings shall be provided with entrances that shall guard the full height and width of the openings. Entrances for passenger elevators shall not be less than 6 ft 8 in. (2032mm) in height and [32 in. (813 mm)] 36 in. (914 mm) in width.

§17. Delete subdivision a of rule 110.1 and replace it with the following:

(a) The clear door opening shall be at least thirty-six (36) inches (914 mm) wide and six (6) feet six (6) inches (1981 mm) high. For floor plan of elevator cars, see subsection 4.10.9 of Section 216.

§18 Delete subparagraph c of paragraph 1 of subdivision a, and paragraph 3 of subdivision b of rule 110.2.

§19. Amend rule 110.6 to read as follows:

Rule 110.6 Opening of Hoistway Doors From Hoistway Side

Passenger elevator hoistway doors shall be so arranged that they may be opened by hand from within the elevator car only when the car is within the unlocking zone {see Rule 111.[12] § (c)}, except at an entrance locked out of service.

Means shall not be provided for locking out of service the doors by padlocks or any other physical locking devices at the following landings:

(a) top terminal landing;

(b) bottom terminal landing;

(c) for elevators equipped with Phase I firefighters' service, the designated and [alternate] sky lobby landings shall not be locked out of service when Phase I is effective;

(d) for elevators equipped with Phase II firefighters' service, no landing shall be locked out of service when Phase II is effective;

(e) consecutive vacant floors;

(f) main lobby street floor.

Locking devices electrically inter-connected into the firemen's service key are permitted.

Automatic fire doors, the functioning of which is dependent on the action of heat, shall not lock any elevator hoistway door so that it cannot be opened manually from inside the hoistway, nor shall such doors lock any exit leading from any elevator hoistway door to the outside of the building.

Handles or other means provided for operation of manually operated doors shall be so located that it is not necessary to reach the back of any panel, jamb, or sash to operate them.

§20. Add new subdivisions a, b and c to such rule to read as follows:

Reference Standard 18

110.6a Elevator Landings Provided with Zero Clearance Vestibule.- Elevator landings provided with zero clearance vestibule (not to exceed six(6) inches from the elevator hoistway door) are permissible only when locking devices accessible from the car are installed exclusively on the door that separates the zero clearance vestibule from the occupied floor space.

110.6b Elevator Landing on Floors Other than Designated Level Provided with a Vestibule.- Locking devices at the vestibule will be permitted under any one of the following:

(1) A red telephone is installed in the vestibule near the elevator doors in the elevator lobby to communicate with the main lobby fire command station or building manager's office or to central service station when the building is not attended. A sign shall be posted near the telephone. The sign shall read **"In Case of Fire or Other Emergency, Use This Phone to Contact Lobby or Building Manager or Central Service Station"**.

(2) The locking devices on the vestibule door leading to an exit are released upon the activation of any detection or signaling devices or power failure and are approved as fail-safe meeting the requirements of RS17-3A and RS17-3B of such appendix.

(3) At least one exit stair is located within the vestibule.

110.6c Elevator Door Locking on Consecutive Vacant Floors If elevator doors on consecutive vacant floors are to be locked, the locking devices shall be exclusively on vestibule doors meeting the requirements of Rule 110.6a.

§21. Amend paragraphs 1 and 2 of subdivision a of rule 110.7 to read as follows:

(1) The area of any single vision panel shall not be less than [24 in² (0.016 m²)] twelve (12) in² (0.008 m²), and the total area of one or more panels in any hoistway door shall be not more than [80 in² (0.051 m²)] forty (40) in² (0.026 m²).

(2) Each clear panel opening shall reject a ball [6 in (152mm)] four (4) inches (102 mm) in diameter.

§22. Delete subparagraph b of paragraph 4 of such subdivision of such rule.

§23 Add word tools at the end of subparagraph b of paragraph 8 of, and new paragraph 9 to such subdivision of such rule to read as follows:

(9) Vision panels shall be protected in accordance with the provisions of Rule 204.2e(6).

§24. Delete subdivision f of rule 110.11 and re-adopt to read as follows:

(1) Bottom Guides.- Bottom guides shall conform to the following:

(a) The bottom of each panel shall be guided by two or more members.

(b) Guide members shall be securely fastened.

(c) The guide members and any reinforcements or guards shall engage the corresponding member by no less than one forth (¼) inch (6.3mm).

§25. Delete paragraph 6 of subdivision c and subdivision e of rule 110.13.

§26 Add paragraph 6 to subdivision a of rule 110.15 to

read as follows

(6) BS&A or MEA label shall be provided for the entire entrance assembly where required by this rule.

§27 Amend title of section 111 to read as follows:

SECTION 111 HOISTWAY-DOOR LOCKING DEVICES AND ELECTRIC CONTACTS, [AND] HOISTWAY ACCESS SWITCHES AND ELEVATOR PARKING DEVICES

§28. Amend the first sentence of subdivision d of rule 111.2 to read as follows: new and replacement Interlocks shall conform to the following:

111.2 d General Design Requirements.- Both new and replacement Interlocks shall conform to the following requirements:

§29 Delete subparagraphs d and e of paragraph 4 of and add new paragraph 8 to such subdivision of such rule to read as follows:

(8) Interlocks shall be MEA accepted or BS&A approved.

§30 Delete rule 111.3 in its entirety.

§31. Amend paragraph 2 of subdivision c of rule 111.4 to read as follows:

The certifying agency's name, [or] date of approval and identifying number or symbol;

§32. Add rule 111.8 to read as follows:

Rule 111.8 Elevator Parking Device

111.8a Where Required and Location

(1) An elevator parking device shall be provided at one landing if:

(a) the doors are not automatically unlocked when the car is within the unlocking zone; or

(b) the doors are not operable from the landing by a door-open button or floor button.

(2) Parking devices may be provided at other landings.

(3) This device shall be located at a height not greater than 6ft. 11 in.(2108 mm) above floor

111.8b General Design Requirements.- Parking devices shall conform to the following requirements:

(1) They shall be mechanically or electrically operated.

(2) They shall be designed and installed so that friction or sticking or breaking of any spring used in the device will not permit opening or unlocking a door when the car is outside the landing zone of that floor.

(3) Springs, where used, shall be of the restrained compression type which will prevent separation of the parts in case the spring breaks.

§33. Add rule 111.9 to read as follows:

Rule 111.9 Access to Hoistway for Inspection, Maintenance or Repairs

Access means conforming to the requirements of either Rule 111.6a or 111.7a shall be provided at one upper landing to permit access to top of car, and at the lowest landing if this landing is the normal point of access to the pit.

§34. Add rule 111.10 to read as follows:

Rule 111.10 Devices for Making Inoperative Hoistway-

Reference Standard 18

Door Interlocks or Car-Door or Gate Contacts

Devices other than those specified in Rule 111.7 and Rule 210.1e shall not be installed to render inoperative hoistway-door interlocks or car-door or gate electric contacts (also see Rule 1203.4). Both new and existing elevators shall comply with the provisions of this rule.

§35. Add rule 112.7 to read as follows:

Rule 112.7 Power Operated Horizontal Opening Gates

Horizontal power operated gates shall not be permitted on automatic passenger elevators except in private residence elevators.

§36. Add new paragraphs 1 and 2 to subdivision f of rule 201.4 to read as follows:

(1) A fixed inclined ladder shall be provided where the top of the buffer cylinder is over five (5) feet in height above the pit floor.

(2) A fixed vertical or inclined ladder fitted with an inspection and maintenance platform with guard rails as necessary shall be provided where the top of the car buffer cylinder is over seven (7) feet from the pit floor.

§37. Add the new sentence to the first paragraph of rule 202.4 to read as follows:

Rule 202.4 Compensating Chain or Rope Fastenings

In suspending chains from the frames, provision shall be made for overtravel by looping the chains on "S" hooks fastened to the frames. Compensating chains or ropes shall be fastened to the counterweight frame directly or to a bracket fastened to the frame and shall not be fastened to the tie rods.

§38. Add rule 202.5 to read as follows:

Rule 202.5 Counterweight Material

Counterweight material shall be only steel, iron or lead having a minimum melting temperature of 620 degrees F.

§39. Add new paragraph to subdivision f of rule 204.1 to read as follows:

A guardrail shall be provided where the space between the car enclosure and the nearest wall surface exceeds eight (8) inches. This rail shall be level with the top of the crosshead in the area of the enclosure roof where the top emergency exits are located. In no case shall the guardrail be less than twenty four (24) inches above the car top.

§40. Amend paragraph 1 and subparagraph d of such paragraph and add new subparagraphs e, f and g to such paragraph of subdivision i of such rule to read as follows:

(1) Apparatus or equipment not used in conjunction with the function or use of the elevator shall not be installed inside of any elevator car and permanently installed freight handling equipment in residential passenger elevators shall be prohibited except as follows:

(d) picture frames, graphic display boards, plaques, and other similar visual displays including one (1) advertising sign in commercial buildings limited to three and one half (3½) square feet in area shall be mounted to withstand the required elevator tests without damage. All edges shall be beveled or rounded. The material shall conform to the requirements of Rule 204.1b and 204.2a. When attached to the car wall less than 7 ft above the floor, projections from the car wall, excluding support rails, shall not be greater

than 1½ in (38 mm).

(e) small directories and signs relating to building operation including "No Smoking" signs are permitted.

(f) mirrors in cars in multiple dwellings shall be located to permit a view of the inside by persons entering the car as per Section 27-987(e) of article one of subchapter eighteen of such chapter.

(g) an inspection certificate issued by the commissioner shall be posted as per Section 27-1004 of article four of such subchapter of this chapter.

§41 Add the following new paragraph to subparagraph f of paragraph 2 of subdivision j of such rule to read as follows:

Automatic operation elevators with side emergency exit located in multiple dwelling shall be provided with a tumbler type lock of at least 5-pin type in addition to the lock specified in this rule.

§42. Amend subdivision a of rule 204.2 to read as follows:

204.2a Material for Car Enclosures, Enclosure Linings, and Floor Coverings.- All materials exposed to the car interior and the hoistway shall be metal, laminated glass {Rule 204.1h(3)(a)}, or shall conform to the following.

(1) Materials in their end use configuration, other than those covered by Rules 204.2a(2), and (3), and (4), shall conform to the following requirements, based on the tests conducted in accordance with the requirements of ASTM E 84, UL 723, or NFPA 255:

(a) flame spread [index] rating of 0 to [75] 50;

(b) smoke development of 0 to [450.] 100;

(c) toxicity shall meet the requirements of Section 27-348(e) of the Building Code.

(2) [Napped, tufted, woven, looped, and similar materials in their end use configuration on car enclosure walls shall conform to the requirements of Section 1104. The enclosure walls to which this material is attached shall conform to the requirements of Rule 204.2a(1).] Materials for insulating, sound deadening or decorative purposes may be used for lining enclosures if firmly bonded flat to the enclosure without intervening air spaces. Such materials shall not be padded or tufted, shall be Class A interior finish pursuant to Section 27-348(b) of the Building Code and shall have a smoke development rating of 0 to 25 pursuant to Section 27-348(d) of the Building Code.

(3) Padded protective linings, for temporary use in passenger cars during the handling of freight, shall be of materials conforming to [either] Rule 204.2a(1) [or (2)]. The protective lining shall clear the floor by not less than 4 in. (102 mm).

(4) Floor covering, underlayment, and its adhesive shall [have a critical radiant flux of not less than 0.45 W/cm² as measured by ASTM E 648.] meet the requirements of section 27-351(d) of the Building Code.

(5) Handrails, operating devices, ventilating devices, signal fixtures, audio and visual communication devices, and their housings are not required to conform to the requirements of Rule 204.2a(1) through (4).

§43. Amend paragraph 1 and add new paragraph 6 to subdivision e of rule 204.2 to read as follows:

Reference Standard 18

(1) be of a total area of not more than [144 in² (0.093 m²),] 72 in² (0.047 m²), and contain no single glass panel having a width exceeding [6 in. (152 mm)] 4 in. (101 mm);

(6) be protected by protective grills made of number 16 gage stainless or galvanized steel in accordance with the following specifications:

(a) Grills shall be sized to fit within or over the vision panel frame and completely cover the vision panel opening in both the elevator car doors and hoistway doors.

(b) Grills and vision panel frames shall be secured by means of non-reversible screws or other tamper proof fasteners.

(c) Grills shall contain openings that shall not be larger than ¾ inch by ¾ inch or ¾ inch in diameter. Such openings shall be spaced at one (1) inch center to center.

(d) All cut edges shall be deburred.

(e) The provisions of subparagraph (6) shall apply to both new and existing passenger cars. Requirements for such grills may be waived if certification is submitted that said elevator is operated manually or twenty-four (24) hour doorman service is provided. A security guard shall not be considered doorman service.

(f) For the purposes of this subparagraph, a vandal resistant one-quarter (¼) inch polycarbonate sheet, such as Lexan, in two (2) layers, one (1) on each side of the required wire glass, may be used in lieu of the metal protective.

§44. Amend paragraph 2 of subdivision h of rule 204.4 to read as follows:

(2) Gates shall be constructed of wood only for private residence elevators [or] and of metal, and shall be of a design which shall reject a ball 2 in. (51 mm) in diameter.

§45 Amend paragraphs 1,2 and 3 of subdivision m of such rule to read as follows:

(1) for horizontally sliding doors or gates, when the clear open space between the leading edge of the door or gate and the nearest of the jamb does not exceed [2 in. (51 mm)] 1 in. (25 mm)[, except as specified in Rule 204.4m(4)];

(2) for vertically sliding counterweighted doors or gates, when the clear open space between the leading edge of the door or gate and the car platform sill does not exceed [2 in. (51 mm)] 1 in. (25 mm);

(3) for horizontally sliding center-opening doors, or vertically sliding biparting counterbalanced doors, or when the door panels are within [2 in. (51 mm)] 1 in. (25 mm) of contact with each other[, except as specified in Rule 204.4m(4)].

§46. Delete paragraph 4 of such subdivision of such rule.

§47. Amend the title of subdivision c of rule 204.5 to read as follows:

204.5c Vertically Sliding Doors [or Gates].

§48. Amend paragraph 4 of such subdivision of such rule to read as follows:

(4) Each elevator shall be provided with [an] a guarded electric light and convenience outlet fixture on the car top and under each elevator car platform for inspection and

maintenance purposes.

§49. Amend the opening paragraph of rule 205.14 to read as follows

A metal plate shall be securely attached to each safety device so as to be readily visible, and shall be marked in a legible and permanent manner with letters and figures not less than ¼ in. (6.3 mm) in height indicating the following:

§50 Amend rule 208.10 to read as follows:

Rule 208.10 Numbering of Driving Machines

A New York City designated elevator device number is assigned by the Elevator Division of the New York City Department of Buildings to each driving machine in every machine room. Such numbers shall be engraved into the metal tag in block type with a minimum of ¼ in. height and securely attached in a permanent manner to the driving machine, controller, MG set or drive unit and the disconnecting means. In addition, [W] when the machinery of more than one elevator is in a machine room, each driving machine shall be assigned a different number which shall be painted on or securely attached to the driving machine. (See also Rule 211.9.)

§51. Amend rule 208.11 to read as follows:

Rule 208.11 Means for Inspection of Gears

Each gear case of geared machines shall have access to permit inspection of the contact surfaces of the gears. [Such access need not provide a direct view of all gears, but shall be located and sized adequately to allow access by fiber optic or similar visual inspection instrumentation.]

§52 Add paragraph 3 to subdivision b of rule 209.3 to read as follows:

(3) Final limit switches and bracket shall be permanently secured.

§53 Amend first paragraph of subdivision e of rule 210.2 and add new paragraph 5 to such subdivision of such rule to read as follows:

(e) Emergency Stop Switch.- [An emergency stop switch is prohibited in the car on passenger elevators.] On all [freight] elevators, an emergency stop switch shall be provided in the car, and located in or adjacent to each car operating panel. When opened, this switch shall cause the electric power to be removed from the elevator driving machine motor and brake.

(5) cause the alarm bells to sound as required by Rule 211.1 when activated in elevators that are operated at any time without a designated in-car operator.

§54 Amend subdivision b of rule 210.4 to read as follows:

(b) Electrical equipment shall [be certified to] meet the requirements of CSA B44.1/ASME A17.5.

§55. Add new subdivision d to rule 210.8 to read as follows:

(d) the power supply line disconnect switch of direct current elevators having rheostat control is opened.

§56. Delete rule 210.14.

§57 Delete rule 210.15.

§58. Add the following sentence to the end of first

Reference Standard 18

paragraph of subdivision b of rule 211.1.

In the event that this service is disconnected, the emergency service shall notify the Commissioner promptly of the date of such discontinuance. In institutional buildings, the required telephone shall provide communication with building personnel.
§59. Delete subdivision c of such rule.

§60. Amend subdivision a of rule 211.3 to read as follows:

211.3a Phase I Emergency Recall Operation.- A [three] two-position key-operated switch shall be provided [only] at the designated level and at the sky lobby level when provided for each single elevator or for each group of elevators. The [three] two-position switch shall be marked ["BYPASS," "OFF," and "ON"] "NORMAL," and "FIREMAN SERVICE" [(in that order) with the "OFF" position at the center position]. The [three] two-position switch shall be located in the lobby [within sight of the elevator or all elevators in that group] call button fixture or in a separate fixture which shall be located within four (4) feet from the lobby call button fixture and not exceeding six (6) feet above the floor level and shall not be located behind a locked door or cover. The commissioner with concurrence of the fire commissioner may allow [A] an additional two-position ["OFF" and "ON" in that order] "NORMAL" and "FIREMAN SERVICE" key-operated switch [shall be permitted at a central control station for fire department operations] at another location. [The switches shall be rotated clockwise to go from the "OFF" to "ON" position.] All keys shall be removable [only in the "OFF" and "ON"] from any position[s].

No device, other than Phase I switch(es) [or the fire alarm initiating device at the elevator floors] , the smoke detectors in the elevator lobbies, machine room, or hoistway (Rule 211.3b1), or the waterflow alarm (Rule 211.b2), shall initiate Phase I operation [(see ANSI/NFPA 72, definition for initiating device)].

Normal elevator service shall be provided and the operation from the smoke detectors required by Rule 211.3b(1) or the waterflow alarm Rule 211.3b(2) shall be functional when Phase I switches are in the ["OFF"] "NORMAL" position [, except as specified in Rule 211.3a(10)].

[When the designated level three-position switch is in the "BYPASS" position, normal elevator service shall be restored regardless of the status of the smoke detectors required by Rule 211.3b.]

When [three-position switch or two-position] a switch [, when provided,] is in the ["ON"] "FIREMAN SERVICE" position:

(1) All cars controlled by this switch that are on automatic service shall return nonstop to the designated or sky lobby level and power-operated doors shall open and remain open. On cars with two entrances, if both entrances can be opened at the designated or sky lobby level, the doors serving the lobby where the [three] two-position Phase I switch is located shall open and remain open.

(2) A car traveling away from the designated or sky lobby level shall reverse at or before the next available landing without opening its doors.

(3) A car stopped at a landing shall have the in-car

emergency stop switch [or in-car stop switch] rendered inoperative as soon as the car moves away from the landing. A moving car shall have the in-car emergency stop switch [or in-car stop switch] rendered inoperative without delay. Once the in-car emergency stop switch [or in-car stop switch] has been rendered inoperative, it shall remain inoperative while the car is on Phase I operation. All other stop switches required by Rule 210.2 shall remain operative.

(4) A car standing at a landing other than the designated or sky lobby level, with the doors open and the in-car emergency stop switch [or in-car stop switch] in the run position, shall conform to the following:

(a) Elevators having automatic power-operated horizontally sliding doors shall close the doors without delay and proceed to the designated or sky lobby level.

(b) Elevators having automatic power-operated vertically sliding doors provided with automatic or momentary pressure closing operation per Rule 112.3d shall have the closing sequence initiated without delay in accordance with Rules 112.3d(1), (2), (3), and (5), and the car shall proceed to the designated or sky lobby level.

(c) Elevators having power-operated doors provided with continuous pressure closing operation per Rule 112.3b or elevators having manual doors, shall be provided with a visual and audible signal system to alert an operator to close the doors and shall, when the doors are closed, conform to the requirements of Rule 211.3a. Sequence operation, if provided, shall remain effective.

(5) Door reopening devices, for power-operated doors, which are sensitive to smoke or flame shall be rendered inoperative without delay. Door reopening devices not sensitive to smoke or flame (e. g., mechanically actuated devices) are permitted to remain operative. Door closing for power-operated doors shall conform to the requirements of Rule 112.5.

(6) All car and corridor call buttons shall be rendered inoperative. All call registered lights and directional lanterns shall be extinguished and remain inoperative. Car position indicators, where provided, shall remain in service. Hall position indicators, where provided, shall be extinguished and remain inoperative except at the designated or sky lobby level and the central control station, where they shall remain in service for fire department operations.

[(7) Where provided on installations with vertical slide doors, corridor door open and corridor door close buttons shall remain operative.]

[(8)](7) All cars shall be provided with an illuminated visual and audible signal system which shall be activated to alert the passengers that the car is returning nonstop to the designated or sky lobby level. [The visual graphic shall be shown in Fig. 211.3a.] The signals shall remain activated until the car has returned to the designated or sky lobby level.

[(9)](8) A car stopped at a landing shall have the in-car door open button rendered inoperative as soon as the car moves away from the landing. A moving car shall have the

Reference Standard 18

in-car door open button rendered inoperative without delay. Once the in-car door open button has been rendered inoperative, it shall remain inoperative until the car has returned to the designated or sky lobby level.

[10] If an additional two-position Phase I switch is provided, it shall not affect Phase I operation if the designated-level smoke detector [Rule 211.3b(2)] has been activated

(11) The "BYPASS" position on the three-position Phase I switch shall not restore the elevator to normal service if the two-position Phase I switch is in the "ON" position.]

§61 Delete subdivision b of rule 211.3 and re-adopt it to read as follows:

211.3b Phase I Fire Alarm Activation

(1) Smoke Detectors.- Except as set forth in subparagraph k of this paragraph, smoke detectors installed in accordance with subparagraphs a,b,c or d shall initiate Phase I emergency recall operation.

(a) In buildings where fire command station is not required or provided, a single smoke detector shall be installed in the ceiling of each elevator landing over the call button on each floor.

(b) In buildings where fire command station is required or provided, either of the following shall apply:

(1) An analog addressable smoke detector employing alarm verification shall be installed in the ceiling of each elevator landing over the call button on each floor or

(2) Two (2) smoke detectors for cross-zoning shall be installed in the ceiling of each elevator landing on each floor and spaced as follows:

(i) in elevator landing containing one (1) or two (2) elevators, the distance between smoke detectors shall be the width of the hoistway(s) but not greater than ten (10) feet.

(ii) in elevator landing containing three (3) or more elevators, the distance between smoke detectors shall be the distance between the centerlines of the end elevators but not greater than twenty (20) feet.

(c)(1) In associated elevator machine rooms of the buildings of subparagraph a above, a smoke detector shall be installed.

(2) In associated elevator machine rooms of the buildings of paragraph b above, either of the following shall be installed:

(i) An analog addressable smoke detector employing alarm verification or

(ii) At least two (2) smoke detectors for cross zoning, spaced twenty (20) feet apart but not closure to the hoistway enclosure walls ¼ distance of the width of the machine room.

(d) A smoke detector shall be installed at top of the hoistway(s) of the buildings classified in occupancy group J-2. Smoke detectors may be installed in any other hoistway and shall be installed in hoistways, which are sprinklered (see Rule 102.2).

(e) Smoke detectors are not required in elevator landings at unenclosed landing which are open to the outside air.

(f)(1) In the buildings of subparagraph a above, where a single smoke detector is installed in the elevator landing, the activation of a smoke detector in any elevator landing, other than the sky lobby shall cause all automatic elevators

servicing floor on which the sensing device is activated to return nonstop to the designated or sky lobby level, except as modified by the commissioner.

(2) In the buildings of subparagraph b above, where either an analog addressable smoke detector or two (2) smoke detectors for cross-zoning are installed, the activation of either an analog addressable smoke detector or any one of two smoke detectors for cross-zoning in any elevator lobby shall only annunciate at the fire command station with floor identification. After verification of an alarm condition either from the analog addressable smoke detector or from the first detector of cross-zoning detectors, the completion of delayed time period of an analog addressable smoke detector or the activation of both smoke detectors for cross-zoning in any elevator lobby other than the sky lobby shall cause all automatic elevators servicing floor on which the sensing device is activated to return nonstop to the designated or sky lobby level, except as modified by the commissioner.

(3) In associated machine rooms of item 1 of subparagraph c above, the activation of smoke detector in the elevator machine room shall cause all automatic elevators having any equipment located in that machine room, and any associated elevators of a group automatic operation to return nonstop to the designated or sky lobby level, except as modified by the commissioner.

(4) In associated machine rooms of item 2 of such subparagraph above, where either an analog addressable smoke detector or two (2) smoke detectors for cross-zoning are installed, the activation of either an analog addressable smoke detector or any one of two smoke detectors for cross-zoning in any elevator machine room shall only annunciate at the fire command station with floor identification. After verification of an alarm condition either from the analog addressable smoke detector or from the first detector of cross-zoning detectors, the completion of delayed time period of an analog addressable smoke detector or the activation of both smoke detectors for cross-zoning in any elevator machine room shall cause all automatic elevators having any equipment located in that machine room, and any associated elevators of a group automatic operation to return nonstop to the designated or sky lobby level, except as modified by the commissioner.

(5) The activation of a smoke detector in any elevator hoistway shall cause, in addition to the activation of mechanical ventilation if provided (see Rule 100.4) all automatic elevators having any equipment located in the hoistway and any associated elevators of a group automatic operation, to return nonstop to the designated or sky lobby level.

The operation of this subparagraph shall conform to the requirements of Rule 211.3a.

(g) When the lowest landing of elevators is above the designated level, such as the sky lobby level, the activation of smoke detectors {Rule 211.3b(1)} in the sky lobby level or the activation of the waterflow alarm {Rule 211.3b(2)} on the sky lobby floor shall cause such elevators to return nonstop to a floor two (2) stories above the sky lobby level

Reference Standard 18

or in the absence of a stop at that floor, to the nearest landing above the sky lobby level.

(h) Elevators shall only react to the first smoke detector zone that is activated for that group.

(i) Smoke detectors and/or smoke detector systems shall not be self-resetting.

(j) Activation of smoke detectors to initiate elevator recall shall override any automatic programming for car stops but shall not affect the other elevator safety circuits.

(k) The following buildings shall be exempt from the requirements of this rule:

(1) Buildings classified in occupancy group J-2, except they shall comply with the requirements of Rule 211.3b(1)d.

(2) Buildings classified in occupancy group J-3.

(3) Existing buildings less than 75' in height classified in occupancy group G which have at least one (1) elevator available at all times for immediate use by the fire department and which are in compliance with the fire department's regulations governing "life safety requirements for schools with students having physical disabilities".

(4) Existing office buildings, one hundred feet or more in height and existing high buildings as defined by Section 27-232 of the Building Code equipped throughout with an automatic sprinkler system including a waterflow alarm.

(2) Sprinkler Waterflow Alarm.- A building equipped throughout with an automatic sprinkler system, a waterflow alarm when activated shall initiate Phase I (Rule 211.3a) emergency recall operation.

§62 Amend subdivision c of rule 211.3 to read as follows:

211.3c Phase II Emergency In-Car Operation.- A three-position (["OFF"] "NORMAL", "HOLD", and ["ON"] "FIREMAN SERVICE" in that order) key-operated switch shall be provided in an operating panel in each car. The switch shall be rotated clockwise to go from the ["OFF"] "NORMAL" to "HOLD" to ["ON"] "FIREMAN SERVICE" position. It shall become effective only when the designated or sky lobby level Phase I switch (Rule 211.3a) is in the ["ON"] "FIREMAN SERVICE" position or a smoke detector (Rule 211.3b(1)) or waterflow alarm (Rule 211.3b(2)) has been activated, and the car has returned to the designated or [alternate] sky lobby level by Phase I operation.

The key shall be removable in [each] "NORMAL" or "HOLD" position. The ["OFF,"] "NORMAL," "HOLD," and ["ON"] "FIREMAN SERVICE" positions shall not change the operation until the car is at a landing with the doors in the normal open position.

(1) When the Phase II switch is in the ["ON"] "FIREMAN SERVICE" position, the elevator shall be on Phase II operation, [for use by trained emergency service personnel only,] and the elevator shall operate as follows:

(a) The elevator shall be operable only by a designated person in the car.

(b) All corridor call buttons and directional lanterns shall remain inoperative. Car position indicators, where provided, shall remain in service. Hall position indicators, where provided, shall remain inoperative except at the designated level, sky lobby level and the central control station, where

they shall remain in service for fire department operations.

(c) The opening of power-operated doors shall be controlled only by a continuous pressure door open button. If the button is released prior to the door reaching the normal open position, the doors shall automatically re-close. Rules 112.4(a), 112.3c, and 112.3d do not apply. On cars with two entrances, if both entrances can be opened at the same landing, separate door-open buttons shall be provided for each entrance.

(d) Open power-operated doors shall be closed only by [continuous] momentary pressure on the door close button. [If the button is released prior to the doors reaching the fully closed position, horizontally sliding doors shall automatically reopen and vertically sliding doors shall automatically stop or stop and reopen.] On cars with two entrances, if both entrances can be opened at the same landing, a separate door-close button shall be provided for each entrance.

(e) Opening and closing of power operated car doors or gates which are opposite manual swing or manual slide hoistway doors shall conform to the requirements of Rules 211.3c(1)(c) and (d). Door opening and closing buttons shall be provided in the car operating panel.

(f) [All door] Door reopening devices [shall be] rendered inoperative, per Rule 211.3a(5) shall remain inoperative. Full speed closing is permitted. Corridor door opening and closing buttons, if provided, shall be rendered inoperative.

(g) Every car shall be provided with a button marked "CALL CANCEL" located in the same car operating panel as the Phase II switch, which shall be effective during Phase II operation. When activated, all registered calls shall be canceled and a traveling car shall stop at or before the next available landing.

(h) Floor selection buttons shall be provided in the car to permit travel to all landings served by the car and they shall be operative at all times. Means [to] which prevent the operation of the floor selection buttons or door operating buttons shall be rendered inoperative.

(i) A traveling car shall stop at the next available landing for which a car call was registered. When a car stops at a landing, all registered car calls shall be cancelled.

(j) The emergency stop switch shall remain operative.

(2) When the Phase II switch is in the "HOLD" position, the elevator shall be on Phase II operation. The car shall remain at the landing with its doors open. The door close buttons shall be inoperative.

(3) When the Phase II switch is in the ["OFF"] "NORMAL" position, the elevator is not at the designated or sky lobby level and Phase I is in effect, the elevator shall operate as follows .

(a) Automatic power-operated horizontally-sliding doors shall close automatically and the car shall revert to Phase I operation (Rule 211.3a) upon completion of door closing. All door reopening devices shall remain inoperative. Door open buttons shall remain operative. Full speed closing is permitted. If the Phase II switch is turned to the ["ON"] "FIREMAN SERVICE" or "HOLD" position prior to the

Reference Standard 18

completion of door closing, the doors shall reopen.

(b) Elevators having power operated vertically sliding doors shall have corridor door open and close buttons rendered operative. All door reopening devices shall remain inoperative. Door closing shall be in accordance with the requirements of Rule 211.3c(1)(d). Full speed closing is permitted. If the Phase II switch is turned to the ["ON"] "FIREMAN SERVICE" or "HOLD" position prior to the completion of door closing, the doors shall reopen. The car shall revert to Phase I operation (Rule 211.3a) upon completion of door closing.

(c) Elevators having manual doors shall revert to Phase I operation (Rule 211.3a) upon completion of door closing.

(4) When the Phase II switch is in the ["OFF"] "NORMAL" position and the car is not at the designated or sky lobby level, and Phase I is not in effect, the car shall remain at the landing with the doors open and door-close buttons inoperative[.] and shall remain in Phase II.

(5) Elevators shall only be removed from Phase II operation when :

(a) The Phase II switch is in the ["OFF"] "NORMAL" position and the car is at the designated or sky lobby level with the doors in the normal open position; or

(b) The Phase II switch is in the ["OFF"] "NORMAL" position when Phase I is in effect {Rule 211.3c(3)}.

(6)(a) For all elevators, applications filed after March 12, 1991 (the effective date of adoption of Cal #11-91-BCR), which propose the installation, alteration or change of controller, elevator machinery and any other work, excluding minor alteration and ordinary repairs as defined in Sections 27-124 and 27-125 of article five of subchapter one of this chapter, and applications filed for new elevator, the cost of which exceeds \$10,000 per car over a twelve (12) month period or applications filed for compliance with the requirements of Section 27-996.2 of subchapter eighteen of this chapter shall comply with the requirements of this subdivision.

(b) Applications filed between November 17, 1989 and March 12, 1991 for existing elevators which propose the work described in (6)(a) above, shall comply with the requirements of this subdivision.

(c) In elevators subject to the requirements of (6)(a) and (b) above, a "HOLD" position by means of either a three-position switch or a two-position switch in addition to an existing two position ("NORMAL" and "FIREMAN SERVICE") switch and designate the "HOLD" position by engraving or permanently affixing a label to the operating panel of the elevator car.

(d) Applications filed for the installation or modification of Phase II Emergency In-Car Operations/Fireman's Service in existing elevators for which a permit was issued prior to November 17, 1989 and the work completed by November 16, 1991 need not provide for the retrofitting of a "HOLD" position on the Emergency In-Car Operating switch, however, the permittee can elect to provide a "HOLD" position.

§63. Amend subdivision d of such rule to read as follows:

211.3d Interruption of Power.- Upon the resumption of

power (normal, emergency, [or] standby or actuation of in-car emergency stop switch), the car [may] shall move in the down direction to [reestablish absolute car position] designated or sky lobby level. Restoration of electrical power following a power interruption shall not cause any elevator to be removed from Phase I or Phase II operation.

§64. Add two new subdivisions f and g to such rule to read as follows:

211.3f Emergency Power Selection Switch.- When emergency power is furnished (Rule 211.2) a manual elevator emergency power selection switch shall be provided at the main floor and other levels, approved by the Commissioner to override any automatic sequence operation. If the manual elevator emergency standby power selection switch is of the key-operated type, the switch keys shall conform to the requirements of Rule 211.8.

211.3g Identification of Switches and Buttons

(1) All keyed switch positions and buttons required by this subdivision shall be identified with the appropriate designation in red lettering.

(2) All cover plates for such switches and buttons shall bear the lettering "**FOR FIRE DEPARTMENT USE ONLY.**"

§65. Amend subdivision a of rule 211.4 to read as follows:

211.4a Phase I Emergency Recall Operation.- A [three] two- position key-operated switch shall be provided only at the designated or the sky lobby level for each single elevator or for each group of elevators. The [three] two-position switch shall be marked ["BYPASS," "OFF," AND "ON"] "NORMAL" and "FIREMAN SERVICE" (in that order). The Commissioner with the concurrence of the Fire Commissioner may allow [A] an additional two-position key-operated switch marked ["OFF" and "ON"] "NORMAL" and "FIREMAN SERVICE" (in that order) [may be provided] at [any] other location, however, it shall not affect Phase I operation if the designated-level or sky lobby-level smoke detector or waterflow alarm (Rule 211.4b) has been activated. The switch(es) shall be rotated clockwise to go from the ["OFF"] "NORMAL" to ["ON"] "FIREMAN SERVICE" position.] All keys shall be removable [only in the "OFF" and "ON"] from any position[s].

No device, other than Phase I switch(es), [or] the smoke detectors in the elevator lobbies, machine room, or hoistway (Rule 211.3b1), or waterflow alarm in lieu of smoke detectors in the elevator lobbies (Rule 211.3b2) shall initiate Phase I operation.

When all switches are in the ["OFF"] "NORMAL" position, normal elevator service shall be retained and operation from the smoke detectors or waterflow alarm required by Rule 211.4b shall be functional.

[When the designated-level three-position switch is in the "BYPASS" position, normal elevator service shall be restored independent of the smoke detectors required by Rule 211.4b.]

When a Phase I switch is in the ["ON"] "FIREMAN SERVICE" position, a visual and audible signal shall be

Reference Standard 18

provided to alert the attendant to return nonstop to the designated or [alternate] sky lobby level. The visual signal shall read "FIRE RECALL – RETURN TO {insert level to which the car should be returned (the designated or [alternate] sky lobby level)}. The [signal system] The smoke detectors or waterflow alarm shall be activated when Phase I is in effect.

[If an additional two-position Phase I switch is provided it shall not affect the visual signal if the designated-level smoke detector {Rule 211.3b(2)} has been activated.

The "BYPASS" position on the three-position Phase I switch shall not restore the elevator to normal service if the two-position Phase I switch is in the "ON" position.]

§66. Delete subdivision b of this rule and re-adopt it to read as follows:

211.4b Phase I Smoke Detectors or Waterflow Alarm Devices Activation.- Smoke detectors shall be installed in accordance with the requirements of Rules 211.3b(1)(a),(b),(c), and (d).

Phase I operation, conforming to Rule 211.4a shall be initiated when either any smoke detector, in accordance with the requirements of Rule 211.3b(1)(f) or waterflow alarm, in accordance with the requirements of Rule 211.3b(2) is activated.

(1) When the lowest landing of elevators is above the designated level such as the sky lobby level, the activation of smoke detectors or waterflow alarm in sky lobby or sky lobby floor shall cause such elevators to return nonstop to a floor two (2) stories above the sky lobby level or in the absence of a stop at that floor, to the nearest landing above the sky lobby level.

(2) Elevators shall only react to the first smoke detector zone that is activated for that group.

(3) Smoke detectors and/or smoke detector system shall not be self-resetting.

(4) Activation of smoke detectors to initiate elevator recall shall override any automatic programming for car stops but shall not affect the other elevator safety circuits.

(5) The buildings described in Rule 211.3b(1)(k) and meeting its requirements and buildings equipped throughout with an automatic sprinkler system are exempt from the requirements of this rule.

§67. Amend subdivision b of rule 211.5 to read as follows:

b) When operated by a designated attendant in the car (except hospital emergency service):

(1) elevators parked at a floor shall conform to the requirements of Rule 211.3a[(8)](7). At the completion of a time delay of not less than 15 seconds or more than 60 seconds, elevators shall conform to the requirements of Rule 211.3.

(2) a moving car shall conform the requirements of Rule 211.3.

§68 Delete subdivision c and re-adopt it to read as follows:

(c)(1) Hospital Emergency Service Recall Operation. A two-position key-operated corridor call (Hospital Emergency Service) switch is provided at one or more landings to activate the special control function by authorized or designated personnel. The two-position switch shall be

marked "NORMAL" and "HOSPITAL EMERGENCY SERVICE". Keys shall be removal only in the "NORMAL" position.

(a) When a switch is in the "HOSPITAL EMERGENCY SERVICE" position:

(1) All patient elevator cars equipped with the special control function, override normal automatic operating modes for immediate recall of the patient elevator(s) to the landing at which the call is registered.

(2) On patient elevator cars with two entrances, if both entrances can be opened at the designated level, The doors serving the corridor where the two-position Hospital Emergency Service switch is located shall open and remain open.

(3) A patient elevator car traveling away from the designated level shall reverse at or before the next available landing without opening its doors.

(4) A patient elevator car stopped at a landing other than the designated level, with the doors open and in-car emergency stop switch in the run position, shall close the doors without delay and proceed to the designated level.

(5) A visual and audible signal is activated within the patient elevator car to alert the passengers and/or attendant operator that the "Hospital Emergency Service" function has been activated.

(4) Upon arrival at the registered call landing, power operated doors open automatically and remain in the open position for a predetermined adjustable time period to allow the authorized personnel sufficient time to activate the "In-Car" special operation function.

(6) If the Phase I (Rule 211.3a) recall mode is initiated while the elevator is under "Hospital Emergency Service" recall mode and :In-Car" hospital emergency service is not activated, the elevator shall revert to Phase I Rule 211.3a) operation.

(7) Hospital emergency service corridor recall shall not override fire emergency Phase I (Rule 211.3a) or Phase II (Rule 211.3c) operation in effect.

(c)(2) Hospital Emergency Service In-Car Operation.

A two-position "NORMAL" and " HOSPITAL EMERGENCY SERVICE" key-operated switch is provided in an operating panel inside the patient elevator(s) to activate the "Hospital Emergency Service, a special independent operating mode. The switch shall be rotated clockwise to go from the "NORMAL" to "HOSPITAL EMERGENCY SERVICE" position. It shall become effective only when the designated level corridor call "Hospital Emergency Service" switch is in the "HOSPITAL EMERGENCY SERVICE" position and car has returned to the designated level by "Hospital Emergency Service" recall operation.

(a) When the "In-Car" switch is in the "HOSPITAL EMERGENCY SERVICE" position, the patient elevator shall be on Hospital emergency Service operation, and the patient elevator shall operate as follows:

(1) The patient elevator shall be operable only by a designated person in the car.

Reference Standard 18

(2) Activation of the “In-Car” operating mode removes the patient elevator from normal automatic and/or attendant service.

(3) After the activation of “In-Car” operation mode, the patient elevator(s) shall not be recalled under Phase I (Rule 211.3a) operation.

(4) Doors remain open until the authorized person registers the car call and initiate the door closing function.

(5) The patient elevator shall travel directly to the selected landing overriding normal corridor call demand or Phase I (Rule 211.3a) recall and automatically opens the doors upon the arrival at the selected landing, except when the smoke detector(s) are activated on the selected landing or the waterflow alarm is activated on that floor before the patient elevator has reached the selected landing, the patient elevator shall stop at a floor two stories below the selected landing or in the absence of a stop at that floor, at the nearest landing below the selected landing.

(6) The patient elevator has reached the selected floor and the smoke detector(s) are activated on that landing or the waterflow alarm is activated on that floor before the doors are open, the patient elevator without opening the doors shall travel to a floor two stories below the selected landing or in the absence of a stop at that floor, to the nearest landing below the selected landing.

(7) Doors shall remain open with the audible and visual signal functioning until the “in-Car” switch is turned to the “NORMAL” position or for a predetermined adjustable time period to allow the removal of patient from the car and the patient elevator is placed into automatic, attendant or Phase I (Rule 211.3a) if in effect, operating mode.

(8) Upon transfer from “HOSPITAL EMERGENCY SERVICE” back to normal operation during a fire emergency and Phase I (Rule 211.3a) is in effect, the patient elevator shall be automatically recalled to the designated level.

(c)(3) Hospital Emergency Service Switches Color. Color of the Hospital Emergency Service switches located in corridor at the designated level and inside the patient elevator(s) operating panel shall be “BLUE”.

§69 Delete rule 211.7.

§70. Amend rule 211.8 to read as follows:

The switches required by Rule 211.2 through 211.5 for all elevators in a building shall be operable only by [the same] a city-wide standard key and shall also made operable by the Fire Department standard key. [This key shall not be part of a building master key system. There shall be a key for the designated level switch and for each elevator in the group.] The citywide standard key shall be designed in accordance with the requirements of the Fire Department and shall be obtained only through Fire Department authorization. [These] Citywide standard keys shall be kept on the premises by a person responsible for the maintenance and operation of the elevators in a location readily accessible to authorized [personnel] persons in an emergency, but not where they are available to the public.

[NOTE (Rule 211.8): Local authorities may specify a uniform keyed lock box to contain the necessary keys.]

§71. Delete paragraph 3 of subdivision e of rule 212.9 and

re-adopt it to read as follows:

(3) Suppliers of wedge sockets shall submit certification with an MEA Number after successfully passing the tests described in Rule 212.9e(1) and(2) at an MEA certified testing laboratory to secure MEA acceptance. Sockets shall be tagged with visible permanent manufacturer’s identification with an MEA Number.

§72. Amend rule 213.1 to read as follows:

Rule 213.1 Qualification of Welders

Where required by another Rule of the [this] Code welding of parts, except for tack welds later incorporated into finished welds, shall be done by welders qualified in accordance with the requirements of [Section 5 of ANSI/AWS D1.1.

At the option of the manufacturer or contractor, the welders may be qualified by one of the following:

(a) the manufacturer or contractor;

(b) a professional consulting engineer;

(c) a recognized testing laboratory.] The City of New York. When the manufacturer is located in the City of New York its welders shall be licensed in accordance with the provisions of the Administrative Code. When the manufacturer is not located in the City of New York its welders shall either be licensed in accordance with the provisions of the Administrative Code, or in the alternative, pursuant to paragraphs (f) and (o) of Section 25-01 of Title 2 of the Rules of the City of New York, shall possess documentary evidence from a testing laboratory acceptable to the Commissioner attesting that the applicant has passed the qualification test prescribed by the City of New York.

§73. Adopt section 4.10 Elevators of ANSI A117.1-1986 as modified as a new section 216.

SECTION 216

Passenger Elevators Designed to

Accommodate Persons Having Disabilities

Section 4.10 Elevators

4.10 General

(i) Amend the last sentence of subsection 4.10.1 to read as follows:

Freight elevators shall not be considered as meeting the requirements of this section unless the only elevators provided are used as combination passenger and freight elevators meeting the requirements of rule 207.4 of ANSI A17.1-1996.

4.10.2 Automatic Operations

4.10.3 Hall Call Buttons

4.10.4 Hall Lanterns

4.10.5 Raised Characters on Hoistway Entrances

4.10.6 Door Protective and Reopening Device

4.10.7 Door and Signal Timing for Hall Calls

4.10.8 Door Delay for Car Calls

4.10.9 Floor Plan of Elevator Cars

(ii) Amend subsection 4.10.9 of this section to read as follows:

4.10.9 Floor Plan of Elevator Cars.- The floor area of elevator cars shall provide space for wheelchair users to enter the car, maneuver within reach of controls, and exit from the car. Acceptable door opening and inside dimensions

Reference Standard 18

shall be as shown in Figure 22 with the following exception for the existing installation. The clearance between the car platform sill and the edge of any hoistway landing shall be no greater than [1¼ inch (32 mm)] 1½ inch (38 mm).

Exception:

1. The replacement of an existing elevator car whose clear depth is 48 inches or more and width is 48 inches or more but less than 54 inches and are limited by the existing car platform or hoistway shaft. The door opening shall be 32 inches.

2. The replacement of an existing car need not comply with the requirements of door opening, if the clear depth and width are less than 48 inches and is limited by the existing car platform or hoistway shaft.

3. If the new car door opening is larger than the hoistway door opening, the travel of car shall be limited to the opening of the hoistway door.

4.1010 Floor Surfaces

4.10.11 Illumination levels

4.10.12 Car Controls

4.10.13 Car position Indicators

4.10.14 Emergency Communication.

§74 Amend rule 300.2 to read as follows:

Rule 300.2 Machine Rooms and Machinery Spaces

Machine rooms and machinery spaces shall conform to the requirements of Rule 101.1 through 101.5 and Rule 101.7 and shall be vented to the outside air naturally or mechanically.

§75 Add the following sentence to the end of subdivision g of rule 300.8 to read as follows:

Space above the escape hatch defined by the guard railing shall be designated as the refuge space.

§76 Amend the first paragraph of rule 301.8 to read as follows:

Rule 301.8 Car Safeties

Car safeties shall be provided for roped-hydraulic elevators and [shall be permitted to be provided for] direct-acting hydraulic elevators.[when provided ,c] Car safeties shall conform to the requirements of Section 205 and to the following:

§77. Delete rule 303.7.

§78. Amend paragraph 2 of subdivision a of rule 306.3 to read as follows:

(2) It shall maintain the car within [25mm (1 in.)] 13 mm (1/2 in.) of the landing irrespective of the position of the hoistway door. See subsection 4.10.2 of Section 216.

§79. Amend subdivision b of rule 306.6 to read as follows:

(b) Electrical equipment shall [be certified to] meet the requirements of CSA B44.1/ASME A17.5.

§80. Amend subdivision b of rule 508.4 to read as follows:

(b) Electrical equipment shall [be certified to] meet the requirements of CSA B44.1/ASME A17.5.

§81. Delete PART VI in its entirety.

§82. Amend paragraph 2 of subdivision e of rule 702.4 to read as follows:

(2) Electrical equipment shall[be certified to] meet the requirements of CSA B44.1/ASME A17.5.

§83. Delete section 800 and re-adopt it to read as follows:

SECTION 800

PROTECTION OF FLOOR OPENING

Rule 800.1 Protection required

Floor openings for escalators shall be protected against the passage of flame, heat and/or smoke or gases in the event of fire.

Rule 800.2 Escalators Accredited as a Required Means of Egress

Escalators accredited as a required means of egress shall meet the requirements of Section 27-378 of article five of subchapter six of this chapter.

Rule 800.3 Escalators not Accredited as a Required Means Of Egress

Escalators not accredited as a means of egress shall have the floor openings protected by any one of the following:

800.3(a) Full enclosures- as specified in Rule 800.2 of this section.

800.3(b) Automatic rolling shutters-

Unenclosed escalators, which are not protected as specified in subdivision a of this rule shall be equipped with a power-operated automatic rolling shutter at every floor pierced thereby, constructed of noncombustible materials with a fire resistance rating of not less than one and one-half (1½) hours.

Construction.- The shutter shall close immediately upon the activation of the fire detection system in the building and shall completely close the well opening. The shutter shall operate at a speed of not more than 30 feet per minute (0.15 m/s) and shall be equipped with a sensitive leading edge to arrest its progress when in contact with any obstacle, and to continue its progress on release therefrom. There shall be a manual means of operating and testing the operation of the shutter. The shutters shall be operated by building personnel at least once a week to assure that they remain in proper operating condition.

800.3(c) Sprinkler protection-

In buildings completely protected by an automatic sprinkler system complying with the construction requirements of subchapter seventeen of this chapter, escalator openings shall be protected by a draft curtain and by a deluge sprinkler system designed to form a vertical water curtain.

Draft curtain.- A draft curtain shall be installed in each story of the floor opening. The draft curtain shall enclose the perimeter of the opening and shall extend from the ceiling downward at least twenty-four (24) inches on all sides. The lower edge of the draft curtain shall be not less than twelve (12) inches below the bottom of the sprinkler heads. Sprinkler heads of the deluge sprinkler system shall be within two (2) feet of the draft curtain.

§83A. Amend rule 802.3c to read as follows:

802.3e Clearance Between Balustrades and Steps.-

The clearance on either side of the steps between the steps and the adjacent skirt guard shall be not more than three-sixteenths (3/16) inch, and the sum of the clearances on both sides shall be not more than one-quarter (1/4) inch.

§83B. Delete the EXCEPTION to Rule 802.3c.

§84. Delete rule 805.2 and re-adopt it to read as follows:

Reference Standard 18

Rule 805.2 Starting Devices

In every new and existing escalator, starting devices shall be provided with the combination of a starting switch and a starting button. The escalator shall be started only after the activation of both the switch and the button.

(a) Starting Switch.- Starting switch shall be of continuous pressure spring return type and shall be operated by a cylinder type lock having five-pin, five-disc or five-tumbler combination. Starting switch shall be of three-position type and shall be clearly marked as follows:

NORMAL.- A central position for the key entry and spring return position.

START-UP.- A right side position for starting the escalator in the upward direction.

START-DOWN.- A left side position for starting the escalator in the downward direction.

(b) Starting Button.- Starting button shall be of the constant pressure type and located within six (6) inches from the starting switch. It shall be clearly marked “Starting Button”.

(c) Cover Plate.- The starting devices shall be protected by a locked, transparent cover plate that can be opened by the starting key and clearly marked “For Start Only.”

(d) Location of starting devices.- Starting devices shall be located at top and bottom of the escalator on the right side-facing newel.

NOTE: The starting key shall be kept on the premises at all times and may only be accessible to persons authorized to start escalators. It shall also be made available to the Commissioner or his representative.

§85. Amend paragraph 1 of subdivision a of rule 805.3 to read as follows:

(1) Location.- A red stop button shall be visibly located at the top and bottom landings on the right side facing the escalator. Remote stop buttons are prohibited except that any escalator connected to an automatic fire alarm system shall gradually stop not exceeding the speed of 3 ft per sec² (0.91 m/s²) upon the activation of such system.

§86. Amend subdivision f of such rule to read as follows:

805.3f Skirt Obstruction Device.- Means shall be provided to cause the electric power to be removed from the escalator driving machine motor and brake, if an object becomes caught between the step and the skirt as the step approaches the upper [or] combplate, intermediate device or lower combplate. On units having a run of twenty (20) feet or more intermediate devices shall be provided on both sides of the escalator with devices located at interval of ten (10) feet or less. The activation intermediate devices shall stop the escalator at a rate not greater than 3 feet per second square in the direction of travel. The upper and lower combplate devices shall be located so that the escalator will stop before that object reaches the combplate. The activation of any skirt device shall stop the escalator with any load up to full brake rated load with escalator running {Rules 802.9c(1)(b) and 802.9c(2)(b)}.

§87. Amend the first paragraph of subdivision n of such rule to read as follows:

805.3n Combplate Impact Devices.

Two independent devices, one at the side of the combplate and the other at the center of the front edge of the combplate shall be provided. Devices [which] will cause the opening of the power circuit to the escalator driving machine motor and brake if either:

§88. Add new subdivision q to such rule to read as follows:

805.3q Comb-Step Stop Device.- On every new and existing escalator a comb-step stop device shall be provided at the upper and the lower comb-steps. Any obstruction exerting a pressure of 45 lbs for steps not exceeding thirty two (32) inches in width and 60 lbs for steps over thirty two (32) inches in width between the step tread and comb-step shall activate the comb-step stop device to cause the electric power to be removed from the escalator driving machine motor and brake.

§89 Amend the first paragraph of subdivision k of rule 905.3 to read as follows:

905.3k Comb-Pallet Impact Devices. Two independent devices, one at the side of the comb-pallet and the other at the center of the front edge of the comb-pallet shall be provided. Devices [which] will cause the opening of the power circuit to the moving walk driving machine motor and brake if either:

§90. Add new subdivision l to rule 905.3 to read as follows:

905.3l Comb-Pallet Stop Device.-In every new and existing moving walkway, a comb-pallet stop device shall be provided at the entrance to and exit from a moving treadway. Any obstruction exerting a pressure of 45 lbs for treadway not exceeding thirty two (32) inches in width and 60 lbs for treadway over thirty two (32) inches in width between the moving treadway and comb-pallet shall activate the comb-pallet stop device which will cause the opening of the power circuit to the moving walk driving-machine motor and brake.

§91 Delete rule 1000.1 and re-adopt it to read as follows:

Rule 1000.1 Persons Authorized to Make Inspections and Tests

The inspector shall meet the qualification requirements of the Department of Buildings of the City of New York.

§92. Delete rule 1000.3 and re-adopt it to read as follows:

Rule 1000.3 Installation Placed Out of Service

Where for any reason an installation is placed out of service permanently or temporary (see Section 3 definition) so that it cannot be operated for a definite period, it shall comply with the following requirements:

1000.3a Elevators Are Not in Use.- If these elevators are available for service, all required tests shall be regularly performed. These elevators are similar to those in service except that their power feed lines have been disconnected by opening the main line switch. A periodic inspection shall be made and a fee charged. An elevator inspector shall note such requirements when found on a regular inspection.

1000.3b Elevators Placed Out of Active service (Dismantled).- These elevators shall meet the requirements of Section 3 definition for installation placed out of service. In addition, a Building Notice application shall be filed and

Reference Standard 18

the last inspection fee charged. Thereafter, one (1) additional inspection per year shall be made to verify that the status is unchanged and fees shall be paid for such inspection. Before the installation is put back in service, a Building Notice application is filed. For access, it shall comply with the requirements of Rule 1000.3c(1)(b)(4).

1000.3c Elevators Are Removed and Permanently Discontinued

(1) When a single elevator with one elevator shaftway is removed and permanently discontinued, a Building Notice application shall be filed, fees charged for last inspection and shall meet the following requirements for such discontinuance for sealing of elevator hoistway shaft:

(a) If it is proposed to extend the floor at every story of the building, the new construction shall be the same or of similar construction as the existing adjacent floor and of equivalent or better fire resistive rating. Also the elevator car and guide rails, the counterweight and guide rails, all wire cables and other equipments in the hoistway shaft shall be completely removed.

(b) If the hoistway shaft is to remain open-

(1) in addition to the requirements of subparagraph a above except floor construction, all door and window assemblies opening onto masonry shaftway and masonry enclosed associated machine rooms, except as noted in item 4 of this subparagraph below shall be completely removed and the open space so created shall be filled with the same material of equal thickness, or similar material and of equivalent or better fire restive rating as the adjacent masonry.

(2) all door and window assemblies opening onto hoistway shaft originally enclosed with an open wire screen and subsequently enclosed with other than masonry units (i.e. metal lath and plaster or transite boards), except as noted in item 3 of this subparagraph below, shall remain. However, the door and window assemblies shall be fastened in a closed position and shall be adequately welded shut. The assembly shall, in addition, be enclosed in material of equal thickness, or of similar material and of equivalent or better fire resistive rating as the adjacent enclosure.

(3) the sidewalk elevator door at the street level shall be fastened in a closed position and shall be adequately welded shut. The underside of such door, shall be properly reinforced and supported by steel beams and columns so as to support the same loading as the sidewalk.

(4) Fireman access to the bottom of the hoistway (elevator pit) shall be provided through the door assembly of the pit door and shall meet the following requirements:

(i) if the machine room is located at or near the level of the bottom of the shaftway and is so located that access to the bottom of the shaftway is readily available through the machine room, the door to the machine room shall be kept closed with a substantial dead bolt locking device openable only with an elevator key.

(ii) if the machine room is located other than at or near the level of the bottom of the shaftway or the bottom of the shaftway is not readily accessible through the machine room, the lowermost door opening onto the shaftway shall be kept closed with a substantial dead bolt locking device

openable only with an elevator key. A conspicuous sign of one (1) inch block letters with contrasting background permanently affixed to the door and shall read "HOISTWAY".

(iii) the key to the locking device required in subitems (i) and (ii) above shall be kept by the building superintendent and is readily available to the Commissioner or his representative and the fireman.

(c) The ventilation opening (smoke hole) in the flooring provided at the top of the hoistway immediately below the sheaves or at the level of the top of the machine room floor beams and the ventilation opening at the exterior portion of the machine room shall be maintained.

(d) All electric service to the elevator hoistway and machine room shall be disconnected outside the confines of the elevator hoistway and machine room.

(2) When a single elevator in multi-elevator shaftway is removed and permanently discontinued, a Building Notice application shall be filed, fees shall be charged for the last inspection and shall meet the following requirements for such discontinuance sealing of elevator hoistway shaft.

(a) If it is proposed to extend the floor at every story of the building it shall meet the requirements of subparagraph (a) of paragraph (1) of this subdivision, and the shaft enclosure is rearranged so that the remaining operating elevators are properly enclosed to maintain the integrity of the shaftway.

(b) If the hoistway shaft is to remain open-

(1) in addition to the requirements of subparagraph (a) of paragraph (1) of this subdivision except for floor construction, all door assemblies serving the discontinued elevator, opening onto masonry shaftway shall be completely removed and the open space so created shall be filled with the same material of equal thickness, or of similar material and of equivalent or better fire resistive rating as the adjacent masonry.

(2) all door assemblies serving the discontinued elevator, opening onto hoistway shaft originally enclosed with an open wire screen and subsequently enclosed with other than masonry units (i.e. metal lath and plaster or transite boards), shall remain. However, the door assemblies shall be fastened in a closed position and shall be adequately welded shut. The assembly shall, in addition, be enclosed in material of equivalent or better fire resistive rating as the adjacent enclosure.

§93 Adopt new rule 1000.4 to read as follows:

Rule 1000.4 Escalator Installation Placed Out of Service

1000.4a Escalators Are Not in Use. If these escalators are available for service, all required tests shall be regularly performed. These escalators are similar to those in service except that their power feed lines have been disconnected from the mainline disconnect switch and their entrances have been barricaded. A periodic inspection shall be made and fee charged. An elevator inspector shall note such requirements when found on a regular inspection.

1000.4b Escalators are Discontinued or Placed Out of Active Service.

In addition to the requirements of Rule 1000.4a, a Building Notice application shall be filed and the last inspection fee

Reference Standard 18

charged. Thereafter, one (1) additional inspection per year shall be made to verify that the status is unchanged and fees shall be paid for such inspection. Before the installation is put back in service, it shall be subject to all of the required routine and periodic inspections and tests.

1000.4c Escalators are Removed and Permanently Discontinued. A Building Notice application shall be filed and fees charged for the last inspection. The escalator steps, newels, rails, all wire cables and other equipments of escalator and machinery shall be completely removed.

An opening created by the removal of the escalator, it shall be filled with new construction of the same or of similar construction as the existing adjacent floor and of equivalent or better fire restive rating.

§94 Adopt new rule 1000.5 to read as follows:

Rule 1000.5 Moving Walk Installation Placed Out of Service

1000.5a Moving Walks are Not in Use. If these moving walks are available for service, all required tests shall be regularly performed. These moving walks are similar to those in service except that their power feed lines have been disconnected from the mainline disconnect switch and their entrances have been barricaded. A periodic inspection shall be made and fees charged. An elevator inspector shall note such requirements on a regular inspection.

1000.5b Moving Walks are Discontinued or Placed Out of Active Service. These moving walks shall meet the requirements of Rule 1000.5a except for periodic inspection. In addition, a Building Notice application shall be filed and the last inspection fee charged. There after, one (1) additional inspection per year shall be made to verify that the status is unchanged and fees shall be paid for such inspection. Before the installation is placed back in service, it shall be subject to all of the required routine and periodic inspections and tests.

1000.5c Moving Walks are Removed and Permanently Discontinued. A Building Notice application shall be filed and fees charged for the last inspection. The moving walk treadways, newels, rails, all wire cables and other equipments of moving walk and machinery shall be completely removed. An opening created by the removal of the moving walk shall be covered by new construction of the same or of similar construction as the existing adjacent floor and of equivalent or better fire resisting rating.

§95 Amend rule 1001.1 to read as follows:

Rule 1001.1 Inspection and Test Periods

The routine inspection and tests of passenger and freight electric elevators shall be made at intervals [not longer than 6 months] of five (5) times every two years, or as otherwise provided by the commissioner per Section 27-998(a) of article three of subchapter eighteen of such chapter. All references to Items are to Items in A17.2, Inspections' Manual for Electric Elevators.

NOTE {Rule 1001.1}: See Rule 1010.2 for private residence elevators.

§96 Amend rule 1002.1 to read as follows:

Rule 1002.1 Inspection and Test Periods In addition to the routine inspection and tests (Rules 1001.1 and 1001.2), the inspection and tests specified in Rule 1002.2 shall be

performed at intervals not longer than [1] 2 years, and the inspections and tests specified in Rule 1002.3 shall be made at interval not longer than 5 years.

NOTE {Rule 1002.1}: See Rule 1010.2 for private residence elevators.

§97 Amend title of rule 1002.2 and add new paragraph to such rule to read as follows:

Rule 1002.2 [1] 2 Year Inspection and Test Requirements Exception to 2 year inspection and test requirements of this rule shall be as specified in the following subdivisions.

§98 Amend subdivision a of such rule to read as follows:

1002.2a Oil Buffers. Car and counterweight buffers shall be tested at an interval of not longer than one (1) year as per Section 27-998(a) (2) of the Building Code to determine conformance with the applicable plunger return requirements (Rule 201.4e: Item 5.3.2).

§99 Amend paragraph 1 of subdivision b of such rule to read as follows:

(1) Inspection. All working parts of car and counterweight safeties shall be inspected at an interval of not longer than 1 year as per Section 27-998(a)(1) of the Building Code to determine that they conform to the applicable requirements and Section 1202 (Rules 205.10 and 205.11; Division 112).

§100 Amend subdivision c of such rule to read as follows:

1002.2c Governors. Governors shall be tested at an interval of not longer than one (1) year as per Section 27-998(a)(2) and shall be inspected and operated manually to determine that all parts, including those which impart the governor pull through tension to the governor rope, operate freely. Item 2.28.2(a). In addition to two (2) year inspection, the tag shall be inspected at an interval of not longer than one (1) year.

§101 Add new subdivision o to rule 1003.3 to read as follows:

(o) When controller is changed and mode of operation remains the same, the following tests shall be required:

(1) Full load operational test

(2) 125% test and pull switch at lowest landing after stop for five (5) minutes.

Definition of full load operational test:

(1) Top to bottom at contract speed.

(2) Contract load, stop level ($\pm 1/2$ "') at every stop up and down.

§102 Add new subdivision L to rule 1003.2 to read as follows:

1003.2L Brake. A test of the brake shall be made with 125% of load. When the car returns to the lowest landing, pull the main line switch while the car is being stopped to ensure the brake has set and holds the load.

§103 Amend rule 1004.1 to read as follows:

Rule 1004.1 Inspection and Test Periods

The routine inspection and tests of passenger and freight hydraulic elevators shall be made at intervals [not longer than 6 months] of five (5) times every two (2) years or as otherwise provided by the commissioner per Section 27-998(a) of article three of subchapter eighteen of such chapter. All references to Items are to Items in A17.2.2,

Reference Standard 18

Inspectors' Manual for Hydraulic Elevators.

NOTE: {Rule 1004.1}: See Rule 1010.2 for private residence elevators.

§104 Amend rule 1005.1 to read as follows:

Rule 1005.1 Inspection and Test Periods

In addition to the routine inspections and tests (Rules 1004.1 and 1004.2), the inspections and tests specified in Rule 1005.2 shall be performed at intervals not longer than [1] 2 years, the inspections and tests specified in Rule 1005.3 shall be made at intervals not longer than 3 years, and the inspections and tests specified in Rule 1005.4 shall be made at intervals not longer than 5 years.

NOTE: See Rule 1010.2 for private residence elevators.

§105 Amend the title of rule 1005.2 to read as follows:

Rule 1005.2 [1] 2-Year Inspection and Test Requirements

§106 Add new subdivision d to rule 1005.4 to read as follows:

(d) Full load test will not be required. Pressure test shall be performed in accordance with Item 2.14.2 of ASME A17.2b-1996.

§107 Amend rule 1007.1 to read as follows:

Rule 1007.1 Inspections and Test Periods

Routine inspections and tests of escalators and moving walks shall be made at intervals not longer than 6 months for moving walks and at intervals of five times every two (2) years per Section 27-998(b) of article three of subchapter eighteen of such chapter. All references to Items are to Items in A17.2.3 Inspectors' Manual for Escalators and Moving Walks.

§108 Amend rule 1008.1 to read as follows:

Rule 1008.1 Inspection and Test Periods

In addition to the routine inspection and test (Rules 1007.1 and 1007.2), the inspection and tests specified in Rule 1008.2 shall be performed at intervals not longer than [1] 2 years.

§109 Amend the title of rule 1008.2 to read as follows:

Rule 1008.2 [1] 2-Year Inspection and Test

§110 Add new subdivisions, r, s and t to such rule to read as follows:

1008.2r Combplate Stop Switch.

1008.2s Test Report Form. All testing requirements for escalators required by this rule shall be reported on Form ELV3-Rev-1998 (2 year test for escalators) of the Department of Buildings.

1008.2t Test Tag. 2-year test tag for escalators and moving walks shall be affixed in the vicinity of the lower starting device for escalators and of the starting device and the entrance of the moving walks.

§111 Amend the first paragraph of rule 1010.2 to read as follows:

Rule 1010.2 Private Residence Elevators and Lifts

Private residence elevators and lifts [should be subject to the applicable routine and periodic inspections and tests, and] shall be subject to acceptance inspections and tests specified in Sections [1000 through 1006] 1003 and 1006. [Routine inspection should be performed at intervals not longer than 1 year.]

§112 Amend first paragraph of rule 1010.4 to read as follows:

Rule 1010.4 Dumbwaiters

Dumbwaiters shall be subject to the applicable [routine, periodic and] acceptance inspections and tests specified in Sections [1000 through 1006] 1003 and 1006. [Routine inspections shall be performed at intervals not longer than 1 year.]

§113 Add second paragraph to rule 1102.1 to read as follows:

The lap edges of passenger (A17.1 horizontal slide type) elevator door, including the lap edges of multi-section doors, shall not move from the wall or adjacent panel sufficiently to develop a separation of more than two (2) inches during the fire portion of the test and not more than two and seven-eighth (2 7/8) inches during or immediately following the hose stream test.

§114 Delete section 1104.

§115 Amend subdivision f of rule 1200.4 to read as follows:

1200.4f Labeled and Listed Devices. When a component in a labeled and listed device, including but not limited to interlocks (Rule 111.2), fire doors (Rule 110.15) [, and electrical equipment {Rules 210.4(b), 306.6.6(b),etc.}] is replaced, the replacement component shall be subject to the requirement of [B44.1/A17.5 and /or] the engineering type test in Part XI. When a component in a labeled and listed device of electrical equipment {Rules 210.4(b), 306.6(b), 508.4(b), 702.4(e)(2), etc.} is replaced, the replacement component shall be subject to the requirements of B44.1/ASME A17.5 and/or the engineering type test in Part XI.

§116 Delete subdivision b of rule 1200.5.

§117 Amend subdivision a of rule 1201.11 to read as follows:

1201.11a Interlocks. Where the alteration consists of the installation of hoistway door interlocks, the installation shall conform to the requirements of Rules 111.1, [111.3, 111.5, 111.6, 111.7, 111.9, 111.10, 111.11, 111.12] 111.2, 111.5, 111.6, 111.7, 111.10, and 208.8.

§118 Amend subdivision b of such rule 1 to read as follows:

1201.11b Mechanical Locks and Electric Contacts. Where the alteration consist of the installation of hoistway door combination mechanical locks and electric contacts, the installation shall conform to the requirements of Rules 111.1, [111.4, 111.5, 111.6, 111.7, 111.9, 111.10, 111.11, 111.12] 111.2, 111.3, 111.4, 111.5, 111.6, 111.7, 111.10, 111.12, and 208.8.

§119 Amend subdivision c of such rule to read as follows:

1201.11c Parking Devices. Where the alteration consists of the installation of elevator parking devices, the installation shall conform to the requirements of Rules [111.8, 111.9, 111.10, 111.11, 111.12] 111.5, 111.6, 111.7, 111.8, 111.10, and 208.8.

§120 Amend subdivision d of such rule to read as follows:

1201.11d Access Switches and Unlocking Devices. Where the alteration consists of the installation of hoistway access switches or hoistway door unlocking devices, the installation shall conform to the requirements of Rules [111.9, 111.10,111.11, 111.12] 111.5, 111.6, 111.7,

Reference Standard 18

111.10, and 208.8.

§121 Add new rule 1201.13 to read as follows:

Rule 1201.13 Elevator Alteration in Commercial Buildings Being Converted to Residential Occupancy

All new and existing passenger or freight elevators, located in commercial buildings being converted into an interim multiple dwellings registered with the Loft Board in accordance with Article 7-c of the Multiple Dwelling Law are designated as service elevators and shall comply with Section 211 and Local Law 5 of 1073, Local Law 16 of 1984 and Local Law 17 of 1995 and all applicable revisions. The following items shall comply with this Rule:

(1) Freight Elevators. Existing freight elevators may be used to carry passengers when they have been altered to conform to this Rule.

(2) Machine Rooms. Existing machine rooms or machinery spaces including all access assemblies shall have a minimum fire resistance rating of 1-hour and shall be vented in conformance with the requirements of Rule 100.4.

(3) Location of Equipment and Electrical Wiring. Equipment in machine rooms shall be in conformance with the requirements of Rule 101.2.

(4) Structural Supports. At the machine room level and one story below the machine room, all new beams and columns supports shall be of structural steel. Structural supports of existing wood shall be subject to controlled inspection and shall be properly fire protected. These requirements shall also apply to elevator machine supports located in basements. Supports shall comply with the requirements of Rule 105.1.

(5) Pits. A pit shall conform to the requirements of Rule 106.1.

(6) Hoistway Doors. Hoistway doors, conforming to the requirements of Rule 110.1 shall be self-closing, either vertical or horizontal sliding or swing-type with at least 1-hour fire resistance rating.

(7) Locations of Car Door. The maximum distance between the hoistway face of the car door and hoistway face of the hoistway door shall not exceed 5½ inches and shall conform to the requirements of Rule 204.4e(2).

(8) Vision panels. Vision panels and protective grills on manually operated door shall conform to the requirements of Rules 204.2e and 204.5e. Grills shall be provided on all existing vision panels.

(9) Interlocks and Electrical Contacts. Hoistway doors shall be provided with accepted interlocks and electrical contacts conforming to the requirements of Rule 111.1.

(10) Elevator Parking Devices. When required by Rule 111.8a elevator parking devices shall be provided conforming to the requirements of Rule 111.8b.

(11) Guide Rails. Elevator car and counterweight guide rails conforming to the requirements of Rule 200.1 shall be provided.

(12) Buffers. Buffers conforming to the requirements of Rule 201.1 shall be provided.

(13) Car Enclosures. Materials of elevator car enclosures shall conform to the requirements of Rule 204.2a. Wood

platforms shall conform to the requirements of Rule 203.6d.

(14) Top Emergency Exit. Elevators shall be equipped with a car enclosure, which shall have a top emergency exit conforming to the requirements of Rule 204.1e.

(15) Car Safeties and Governor. Cars shall be provided with a car safety conforming to the requirements of Rule 205.1. Governor rope shall be either of iron or steel and shall meet the requirements of Section 206.

(16) Rated Load. The rated load in pounds for a service car shall be calculated based on inside net platform area conforming to the requirements of the passenger elevator, Rule 207.1.

(17) Terminal Stopping Devices. Terminal stopping devices conforming to the requirements of Section 209 shall be provided.

(18) Operating Devices. Operating devices conforming to the requirements of Rule 210.1 shall be provided.

(19) Ropes. Elevator cars shall be suspended by iron or steel wire ropes conforming to the requirements of Rule 212.1.

§122 Amend paragraph 2 of subdivision b of rule 1202.5 to read as follows:

(2) Where an alteration is made to a side emergency exit, or where a new one is installed, it shall conform to the requirements of Rule 2041j. Side emergency exit may be eliminated but corresponding elevator side emergency exit must also be eliminated.

§123 Amend paragraphs 2, 3, and 4 of subdivision c of such rules to read as follows:

(2) Where an existing enclosure other than specified in Rule 1202.5(c)(1) is retained and new material is installed, the new material and adhesive shall conform to the following requirements, based on the tests conducted in accordance with the requirement of ASTM E 84, UL 723 or NFPA 255:

(a) Flame spread rating of 0 to 25

(b) Smoke development of 0 to [450] 100.

(c) Toxicity shall meet the requirements of Section 27-348(e) of the Building Code.

If the material or combination of materials installed exceeds ¼ in. (6.4 mm) in thickness, the car enclosure shall conform to the requirements of Rule 204.2a(1).

(3) [Napped, tufted, woven, looped, and similar materials shall conform to the requirements of Rules 204.2a(1) and (2) or Rule 1202.5(c)(2) and Sections 1104 and 1106. Adhesive shall conform to the requirements of Rule 1202.5(c)(2).] Materials for insulating, sound deadening or decorative purposes may be used for lining enclosures if firmly bonded flat to the enclosure without intervening air spaces. Such materials shall not be padded or tufted, shall be Class A interior finish pursuant to Section 27-348(b) of the Building Code and shall have a smoke development rating of 0 to 25 pursuant to Section 27-348(d) of the Building Code.

(4) Floor covering, underlayment, and its adhesive shall [have a critical radiant flux of not less than 0.45 W/cm² as measured by ASTM E 648] conform to the requirements of Rule 204.2(a)(4).

Reference Standard 18

§124 Amend subdivision b of rule 1202.10 to read as follows:
1202.10[b]c Increase in Rated Speed

§125 Add new subdivision b to such rule to read as follows:

1202. 10b Decrease in Travel. Where an alteration involves a decrease in travel which eliminates top terminal floor landing, it shall, in addition to requirements of Rule 1202.10a meet the requirements of any one of the following:

(1)(a) If the wall is erected in front of elevator entrance openings, the unused shaftway doors shall be sealed with through-bolts. Electromechanical safety interlocks wired into safety circuit of each elevator shall remain.

(b) New slow-down, normal and final limits for the new top terminal floor landing shall be installed.

(c) Access provisions for the original top floor landing from the car operating panels shall be removed.

(d) The original final limits shall remain operable at the top of the hoistway for safety.

(e) Access to the original top terminal landing shall be provided for maintenance and servicing of hung secondary equipment and inspection of wire rope cables per ASME A17.2 Standards.

(f) Elevator car enclosures shall be equipped with side and top emergency exits.

(2)(a) If the wall is erected in front of elevator entrance openings, a suitable access shall be provided for emergency situations.

(b) Inspection control shall allow qualified personnel to bypass the new limits on speed for maintenance and inspection.

(c) The new top terminal final limit switch shall be design for manual resetting.

(d) The system shall be capable of a double electrical protection with the same run-by (36" for oil hydraulic buffers) clearance to stop mechanically using the counterweight buffer when an over-speed malfunction occurs.

(e) The original top terminal landing shall be available for maintenance and inspection.

(f) The safety interlock must be used for the corridor entrance doors in circuit with an access key provision.

§126 Amend paragraph 1 of subdivision d of rule 1202.12 to read as follows:

(1) When a controller is installed in place of an existing controller, without any change in the type of operation or control, the new controller shall conform to the requirement of Rules 210.4 and 210.9. The installation shall also conform to the requirements of Rules 210.6, 210.7, 210.8, 211.3 through [211.8]211.9, and Section 209.

§127 Amend the last paragraph of rule 1202.13 to read as follows:

Where an alteration is made to firefighters' service operation, the installation shall conform to the requirements of Rules 211.3 through [211.8]211.9.

§128 Add new subdivision e to rule 1202 .14 to read as follows:

1202.14e Wedge Clamp Shackles. Where an alteration is made to provide wedge clamp shackles, the installation shall be filed by the Professional Engineer or the Registered Architect and shall conform to the requirements of Rule

212.9e. In addition, the installation for retrofits, cable repair replacements, etc., shall provide installation of apparatus on both sides of cable ends (car and counterweight) and submit the design of cable hitch plates, clearances between shackles, staggering of shackles for entrance, use of tensioning, isolation bushing and other hardware used in conjunction with the adjustment.

§129 Amend paragraph 3 of subdivision h of rule 1203.8 to read as follows:

Where an alteration is made to firefighters' service operation, the installation shall conform to the requirements of Rules 211.3 through [211.8]211.9.

§130 Amend and re-designate paragraph 3 as 5 and add new paragraphs 3 and 4 to subdivision a of rule 1206.3 to read as follows:

(3) for counterweight cables of drum machines re-shackling at the counterweight ends, 4 years.

(4) In addition to foregoing requirements, rope fastenings shall be renewed when an inspection reveals any evidence of failure at the shackle regardless of the period of time since last re-shackling.

[3)] (5) Where auxiliary rope-fastening devices conforming to the requirements of Rule 212.10 or where car hoist ropes with an additional MEA accepted type emergency clamping devices are installed, refastening at the period specified is not required provided that, where such devices are installed, all hoisting ropes shall be refastened on the failure or indication of failure of any rope fastening.

§131 Amend first paragraph of sub division c of such rule to read as follows:

1206.3c Tags. A metal tag (see Appendix K) shall be securely attached to one of the wire rope fastenings after each resocketing or changing to other types of fastenings, and shall bear the following information:

§132 Amend paragraph 6 of subdivision b of rule 1206.5 to read as follows:

(6) Flexible hose and fitting assemblies shall be replaced by the manufacturers' date indicated on the existing equipment but not less than six (6) years. Hose assemblies that do not indicate a replacement date shall be replaced. Replacement shall conform to requirements of Rule 303.3c (1)(e).

§133 Amend the first paragraph of rule 1207.1 to read as follows:

Rule 1207.1 General Requirements

Any alteration to an escalator shall comply with the requirements of Rules 805.1, 805.2, 805.3a, 805.3e, 805.3f, 805.3n, 805.3q, 805.7, 1200.1, and 1200.2

§134 Amend rule 1207.8 to read as follows:

Rule 1207.8 Combplates

Any alteration of the combplates shall require conformance with the requirements of Rules 805.3n and 805.3q.

§135 Amend the first sentence of the first paragraph of rule 1208.1 to read as follows:

Any alteration to a moving walk shall comply with requirements of Rules 905.2, 905.3a, 905.3e, 905.3f, 905.3k, 905.3l, 905.6, 906.2, 1200.1, and 1200.2.

Reference Standard 18

§136 Amend subdivision a of rule 2000.7 to read as follows:

2000.7a Limitation of Load, Speed, and Travel. The rated load shall be not less than 450 lb (204 kg) or more than 750 lb (340 kg). The lift shall be capable of sustaining and lowering a load as specified in Rule 207.1. The rated speed shall not exceed 30 ft/min (0.15m/s). The travel shall not exceed [12ft (3658mm) nor] 25ft (7621mm) and shall not penetrate [a] more than one floor. Platforms with an area greater than 15 ft² (1.39 m²) shall have a rated load of not less than 750 lb (340 kg).

§137 Amend subdivision a of rule 2100.7 to read as follows:

2100.7a Limitation of Load, Speed, and Travel. The rated load shall be not less than 450 lb (204 kg) or more than [700] 750 lb (340 kg). Platforms with an area greater than 15 ft² (1.39 m²) shall have a rated load of not less than [700] 750 lb (340 kg). The lift shall be capable of sustaining and lowering a load as specified in Rule 207.1. The rated speed shall not exceed 30 ft/min (0.15 m/s). The travel shall not exceed [10 ft (3048 mm) nor] 25 ft (7621 mm) and shall not penetrate [a] more than one floor.

§138 Amend the first paragraph of Rule 2500.13 to read as follows:

When provided, power operation, power opening, and power closing of hoistway doors and car doors [and gates] shall conform to the requirements of Section 112, except as modified by this Rule.

§139 Amend subdivision a of such rule to read as follows: (a) Rule 112.1(b). Vertically sliding doors are not permitted. Power operated swing hoistway doors shall not be permitted with power operated horizontal operated car doors.

§140 Amend paragraph 2 of subdivision a of rule 2501.8 to read as follows:

(2) The inside net platform area shall not exceed 18 ft² (1.67 m²) but not less than 4'X4' with a minimum 32 inches clear door opening. The C/O/P shall be on the strike wall.

§141 Delete Appendix G of ANSI/ASME A17.1-1996 in its entirety.

§142 Delete Appendix H of such standard and re-adopt it to read as follows:

APPENDIX H

SIGNS AT ELEVATOR LANDINGS

Signs at elevator landings shall comply with the requirements of Section 27-391 of article nine of subchapter six of chapter 1 of title 27 of the administrative code.

§143 Add new appendix k to such standard.

APPENDIX K0

TAGS

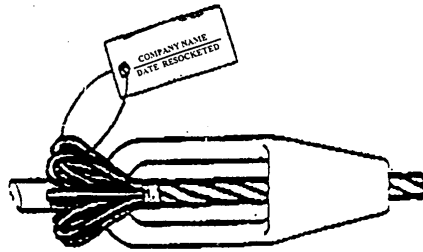

NOT APPROVED

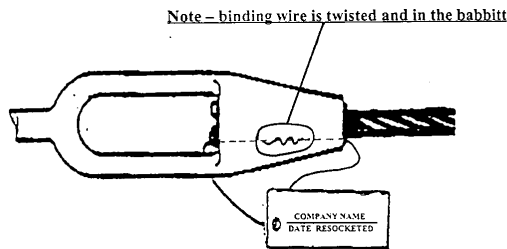

APPROVED METHOD

† DOB 1-16-03; 11-91 BCR

***REFERENCE STANDARD RS 18-3**

ANSI B153.1-1981 Safety Requirements for the Construction, Care and Use of Automobile Lifts.

FS 00-L-360D-1987 Motor Vehicle Lifts.

*DOB 1-16-03; 11-91 BCR; 678-85 BCR; 385-82 BCR

*****REFERENCE STANDARD RS 18-4**

ANSI/ASME MH 14.1-1987 Loading Dock Levelers and Dockboards.

Modifications.-The provisions of ANSI/ASME MH 14.1-1987 shall be subject to the following modifications: The Section numbers are from that standard:

2.1.8 Lighting.-The entire operating area shall be illuminated to provide a distributed intensity of at least five (5) foot candles over the area of operating floor and platforms.

***11-91 BCR; 1156-80 BCR

****REFERENCE STANDARD RS 18-5**

ANSI/ASME B20.1- 1987 Safety Standards for Conveyors and Related Equipment.

Modifications.- The provisions of ANSI/ASME B20.1-1987 shall be subject to the following modifications. The Section numbers are from that standard:

6.21 Vertical Reciprocating Conveyers

6.21.2 Guarding

(e) Controls shall be installed or located so they cannot be actuated by a person on the carrier. Controls shall be of constant pressure type.

(f) Non-operating sides of the conveyer to be guarded to a minimum height of 7 ft. If guarding is fence or expanded metal the mesh must be capable of rejecting a 2" diameter ball. The guarding is required at both levels where the unit penetrates a non-fire rated floor.

6.21.3 Shaft enclosure

Where a vertical conveyer (material lift) penetrates a fire-rated floor a two (2) hour rated enclosure with one and a half (1½) hour rated self-closing fire doors shall be required.

6.21.4 Gates

(a) All lower and intermediate level manual loading and unloading points shall have gates with a minimum of six (6) ft in height. Each gate is equipped with a lock and electric contact to prevent the gates from being opened until the conveyer is at that level.

(b) Upper level gates must be with a minimum of six (6) ft in height and shall be equipped with a lock and electric contact.

6.21.5 Platform Side guards

Platform side guards and gate with electric contact shall be provided with a minimum of six (6) ft in height.

6.21.6 Limitation of Load

The capacity shall be not less than 50 lbs. per sq. ft with a maximum capacity of 2500 lbs.

6.21.7 Speed

The rated speed shall not exceed 25 ft/min (0.15 m/s).

6.21.8 Travel

The maximum travel shall not exceed 25 ft.

6.21.9 Floor Penetration

Not more than one floor penetration shall be permitted.

SECTION 7 OPENING PROTECTION

[7.01] 7.1 Passage through openings

[7.01.1] 7.1.1 Whenever a conveyer or other material-handling device is designed to pass through floors, ceilings, partitions or walls, the plans and specifications shall give the necessary details of the opening protection with respect to location, structural strength, and fire resistance in accordance with the requirements of the Building Code.

Section 5. This revision shall take effect immediately.

[] Matter shown in brackets to be deleted.

___ Matter shown underlined to be added.

{ } Matter shown in brackets replaces brackets

[] of ANSI/ASME A17.1-1996 and ANSI/ASME 17.1A-1997, so that it is not understood as deletion.

Designations used in this revision is as follows:

| | |
|------------------------------|--------------|
| Example is taken from PART X | |
| PART | X |
| SECTION | SECTION 1000 |
| RULE | RULE 1000.3 |
| SUBDIVISION | 1000.3(b) |
| PARAGRAPH | 1000.3(b)(1) |

Reference Standard 18

| | |
|--------------|-----------------------|
| SUBPARAGRAPH | 1000.3(b)(1)(b) |
| ITEM | 1000.3(b)(1)(b)(1) |
| SUBITEM | 1000.3(b)(1)(b)(1)(i) |

Wherever "of such rule," "of such subdivision," etc., is used in any §#, they refer to "rule," "subdivision," etc. of the preceding §#.

** *DOB 1-16-03;11-91 BCR; 1156-80 BCR*

REFERENCE STANDARD RS 18-6 CONSOLE OR STAGE LIFTS

1. Platform or Car Construction.-

(a) Suspension or supporting frames of all console or stage lifts shall be constructed of structural steel, wrought iron shapes, or of any noncombustible material whose strength shall satisfy the loads and stresses requirements of the building code.

(b) The minimum factor of safety of all materials used in car platforms and slings shall conform to the requirements of reference standard RS 18-1.

2. Cables.-Hoisting cables shall have a safety factor conforming to the requirements of reference standard RS 18-1.

3 Hoisting.-Platforms may be operated by cables, plunger, or screw type equipment, and shall maintain a minimum factor of safety of all materials used in operating the platform conforming to the requirements of reference standard RS 18-1.

4. Control.-

(a) Up and down control shall be provided near the lift in a location where it can be easily operated and where the operator will have an unobstructed view of the lift.

(b) An emergency stop switch shall be provided within easy reach of the operator, and when operated, it shall cut off power from the hoisting equipment.

5. Entrance.-When the entrance to such console or stage lift is at one or more points below the stage level, such entrance or entrances shall be provided with a gate or door with mechanical lock and electric contact, or the platform shall be provided with an apron made of sheet steel or plywood covered with 26 gage sheet steel, at the entrance side or sides extending from the platform to below the lowest landing with the platform at its maximum raised position. If the platform rises above the stage level, all unguarded sides shall be provided with aprons extending from the platform to below the stage level.

*REFERENCE STANDARD RS 18-7

ANSI A 10.-41981-Safety requirements for Personnel Hoists. Modifications.-The provisions of ANSI A 10.4-1981 shall be subject to the following modifications:

Add the following sub-section to 25.10.2:

25.10.2.1 Thereafter the rack and pinion type personnel hoist shall be reinspected every ninety (90) days. The inspection

shall include a full load test of the safety device.

Add the following sections to govern the installation, jumping and dismantling of rack and pinion type personnel hoists to Rule 26, Inspections and Tests of Personnel Hoists:

26.1.1.1 Installations of rack and pinion type personnel hoists shall be approved by the Elevator Division. Both a construction application and an elevator application shall be filed by a licensed professional engineer or registered architect. The drawings shall be sealed.

26.1.1.2 The Elevator Division shall be notified at least three (3) days before the inspection date prior to each "cathead" raise, when the travel of the hoist is increased. This inspection shall include the examination of the normal, terminal and final limit stopping devices. All parts of the equipment shall be inspected; and tested to determine that they are in safe operating condition where found necessary by the Elevator Division. A full load test may not be required at this time by the Elevator Division. If an Elevator Division Inspector cannot be present at the time the required tests are made, the qualified private elevator inspectional agency conducting the tests shall:

(1) Submit a statement upon a department form to the Elevator Division certifying the tests which have been conducted and the results thereof within 24 hours of such tests.

(2) Attach a tag showing the date of the tests and the name of the person and/or agency conducting it.

26.1.3.1 Acceptance inspections of new installations shall be made prior to use by the contractor. The Elevator Division shall be notified at least three (3) days before the required acceptance inspection and test. A full rated load test shall be made. All shaftway protection doors, ramps, guards and required safety devices shall be installed and in place. The contractor may apply upon successful completion of the inspection and test for a ninety (90) day temporary elevator certificate (B Form 256).

26.2.1.1.1 All rack and pinion type safeties shall be stamped with their expiration date by the manufacturer and shall be replaced when such date is expired which shall not exceed a period of three (3) years.

26.7 Materials Handling Plan. A materials handling plan shall be provided if a potentially hazardous condition exists because of simultaneous operation of the rack and pinion personnel hoist and either a crane and/or derrick.

26.7.1 The materials handling plan shall be acceptable to Site Safety Coordinator and approved by the Department.

26.7.2 The hoist contractor and the safety coordinator shall be jointly responsible for the enforcement of the provisions of the materials handling plan.

26.8 Dismantling and Removal. The Elevator Division shall be notified on department forms when a rack and pinion type hoist is dismantled and removed.

26.8.1 The notification shall include the elevator application number, the street address locations listed on the construction application, the block and lots and the date of removal.

Reference Standard 18

26.9 Field Inspection. A department field inspection will be scheduled by the Elevator Division upon receipt of proper notification to ascertain the actual job-site conditions and to sign-off the forms documenting the same.

Add the following to Rule 30:

Electrical work shall conform to the New York City Electrical Code.

Welding shall conform to the applicable portions of the Administrative (Building) Code.

**678-85BCR*

REFERENCE STANDARD RS 18-8 POWER OPERATED SCAFFOLDS

1. Construction Requirements for the Scaffold.-

(a) The scaffold shall be constructed of steel conforming to reference standard RS 18-1, rules 203.6(a), (b), (c), and 203.7, or of equivalent metals.

(b) A railing with an intermediate horizontal rail, shall be provided on all four sides of a scaffold. The railing shall be at least 36 in. high on the building side and at least 42 in. high on the other three sides. Design of the guard rail at or near both ends of the scaffold shall include provisions for mounting roller guides.

(c) The spaces between the top guard rails and the scaffold toe board on the outside railing and the end railings shall be filled with metallic mesh, expanded metal, or similar material that shall reject a ball 1 in. in diameter and that shall be capable of withstanding a horizontal force of 75 lbs. at any point with a maximum deflection of 1 in. The railing on the building side shall have mesh below the intermediate rail only.

(d) A solid metal toe board, at least 4 in. high, shall be provided at the floor on all four sides. The bottom of the toe board shall be flush with floor. The toe board shall be capable of withstanding a horizontal force of 75 lbs. at any point with a maximum deflection of 1 in.

(e) A hinged access gate shall be provided in the scaffold railing on the building side. The gate shall be of construction similar to the railing, and the open spaces in the gate shall be filled with material as prescribed in (c) above. With the gate open, the clear width of access shall be at least 18 in.

(f) The gate shall be provided with an interlock that will prevent power operation of the scaffold when the gate is in the open position.

(g) The scaffold dimension parallel with building shall be designated the "length," and shall be measured between the inside surface of the end railings. The dimension perpendicular to the building wall shall be designated the "width," and shall be measured between the inside railing surfaces on the long sides of scaffold. The width of a scaffold shall be at least 28 in. When the building side of the scaffold is of irregular shape, following the contour of a building wall, scaffold "width" shall be measured at the tightest point of the irregularity.

(h) The rated load of a scaffold shall be 50 plf. The maximum number of occupants permitted simultaneously on a scaffold shall be equal to the inside clear length divided

by 5.

(i) The maximum permissible vertical scaffold speed shall be 50 fpm.

(j) The scaffold floor shall have an anti-slip surface with air passage interstices, which must reject a 1/2 in. diameter ball, and shall be designed for a uniform live load of 75 psf. The floor and its supports and bracings shall be able to withstand a concentrated load of 300 lbs. on any random 4 sq. in. of floor area with a maximum deflection of 1/1666 of the span.

(k) A manufacturer's rating plate shall be mounted conspicuously near the access gate on the scaffold. The plate shall be made of non-corrosive material with letters at least 1/4 in. high etched, stamped, or cast on the surface. It shall state the rated load, the maximum number of occupants, and the manufacturer's name and model number.

2. Construction and Design Requirements for Roof Carriage.-

(a) A movable roof carriage and track system shall be provided to move the scaffold in a horizontal direction. The maximum permissible horizontal speed of the roof carriage shall be 50 fpm.

(b) The roof carriage shall be constructed of steel conforming to reference standard RS 18-1, rules 203.6(a), (b), and (c), and 207.7, or of equivalent metals, welded, riveted, or bolted together. The roof carriage construction shall be capable of supporting the scaffold and its rated load plus impact loads imposed by motor stall torque and wind forces with a safety factor conforming to reference standard RS 18-1, rules 203.10 and 203.11.

(c) The design of the roof carriage, track, and track support system shall include means to accurately stop and position the roof carriage at predetermined locations that correspond to the locations of the vertical guides on the building wall.

(d) When the roof track system is not a continuous loop and terminal track ends exist, mechanical end barricades shall be provided together with terminal limit switches.

(e) In the design of roof components of buildings where suspended scaffolds and movable roof carriages are to be used, all forces transmitted to the building structure by such equipment shall be added to normal design loads.

3. Stability of Roof Carriage.-The roof carriage and its support system shall be designed and constructed for structural adequacy and required stability to resist overturning moments occurring with a scaffold carrying its full rated load.

(a) Windforce: 30 psf.

(b) All imposing forces that are caused by moving loads shall be doubled for impact.

(c) If the roof carriage is of open structure type, the effect of windforce or interior components shall be considered as the sum of all framing components areas plus mounted equipment areas projected on a plane perpendicular to the wind direction. No component shall be considered as shielding another component along the wind direction if the separating distance is more than 4 times the smallest

Reference Standard 18

dimension of the windward component.

4. Access for Inspection and Maintenance.-Safe and convenient means of access between roof and roof carriage and between roof carriage and scaffold shall be provided, conforming where applicable to reference standard RS 18-1, rule 101.3.

(a) On installations where movable roof carriages are used, the means of access shall be a permanent part of the carriage design and shall be constructed so as to permit stepping on or off the carriage to or from the roof at any carriage position.

(b) Means of access between a movable roof carriage and its scaffold shall be possible only with the scaffold raised to its top position. Electrical interlocks in the carriage drive motor circuit, and actuated by the scaffold, shall prevent carriage movements until scaffold is in access position.

5. Vertical Guiding of Power Operated Scaffolds.-

(a) Power operated scaffolds shall be guided up and down the face (facade) of a building or structure.

(b) The guiding means shall consist of roller guide shoes engaging vertical guide rails securely attached to the structural members.

(c) Each vertical guide shall be engaged by an upper and a lower roller guide shoe securely attached to the scaffold and its suspension frame. Roller guide shoes shall be spaced at least 48 in. apart vertically. Where the platform is suspended at two points at each end, the vertical guides may be engaged by one guide shoe only.

(d) The two ends of the scaffold shall be supported and hoisted or lowered simultaneously, and means shall be provided to maintain the scaffold approximately at level position at all times to prevent the roller guide shoes from binding on the vertical guides. Out-of-level slope shall not exceed 1/4 in. in 12 in.

(e) Materials for vertical guides, suspension frame, and fastenings shall conform to applicable portions of reference standard RS 18-1, section 200.

6. Construction and Design Requirements for Hoist Machines.-

(a) A hoist machine, whether mounted on the scaffold or the roof carriage, shall be designed and constructed to maintain its component parts in correct alignment to effectively transmit the imposed drum load into the supporting structure.

(b) Wire ropes shall lead from the drums through suitable fairleads to suspension points when the hoist machine is mounted on the scaffold. Wire ropes shall lead from the drums over suitable deflecting sheaves mounted on outriggers from the roof carriage when the hoist machine is located in the roof car.

(c) Chains, clutches, or friction gearing belts shall not be used to connect the drive motor to the winding drum. It shall be necessary to power drive the drive machine to either raise or lower the scaffold.

(d) Drive motors shall meet the requirements of the electrical

code of the city of New York and shall:

(1) Lift the scaffold with 125 percent of the rated load at the rated speed with maximum temperature rise of 50 degrees C. per hr.

(2) Provide dynamic braking.

(3) Be of weatherproof construction with the motor shaft connected to the input shaft of the speed reducer through a coupling capable of transmitting the motor stall torque.

(e) Guards.-All moving, power transmitting, and interacting components of the drive machines shall be effectively guarded to conform to applicable portions of the requirements of rule 19 of the industrial code of the state of New York.

(f) Brakes.-Each hoist machine shall be provided with at least two friction brakes applied by a spring or springs and released electrically.

(1) Each brake shall be able to stop and hold the dead weight of the scaffold and 125 percent of the rated load.

(2) The drum brake shall be adjusted to apply not later than 2 seconds after the drive motor brake at every stopping operation.

(3) At least one brake shall be located at, and applied directly to, the winding drum or an equal strength extension of it. This brake shall have the additional function of reacting to a 40 percent over-speed actuated by an inertia device or a speed governor, either of which must be reset manually.

(4) The second brake shall be located at, and applied on either side of the motor.

(5) All parts of the brakes shall be readily accessible for inspection and cleaning.

(g) Gearing.-Hoist machines shall be provided with speed reducers between the drive motor and the rope drum. Such speed reducers shall be of the meshing gear type, worm and worm gear type, spur gears type, bevel gears type, or a combination of these types. The speed reducer shall be fully enclosed, adequately lubricated, and sealed to prevent leakage.

(1) Such speed reducers shall conform to the requirements of the American Gear Manufacturers Association as listed in Reference Standard RS 18-1, Part XVI.

(2) Material used for gears and shafts in speed reducers shall conform to reference standard RS 18-1, Section 208.

**1156-80 BCR*

(3) The gearbox shall be provided with oil level indicators and removable cover plates or plugs to permit visual inspection of the full width of the faces of the gear teeth.

(4) A data plate of a material resistant to weather and other corrosive agents shall be mounted on the gearbox, and shall bear the following information etched or stamped in 1/8 in. high letters:

Mechanical horsepower.....

Input speed.....R.P.M.

Output speed.....R.P.M.

Service factor.....

Type of lubricant.....

Quantity of lubricant.....Gallons

(h) Drums.-Drums for winding up suspension ropes shall have grooves or contact surfaces capable of withstanding the imposed rope pressure without deformation.

Reference Standard 18

(1) The pitch diameter of the drum shall be at least 40 times the diameter of the rope wound on it.

(2) When grooved drums are used and single or multiple layers of rope are wound on the drum, the groove spacing or distance from centerline-to-centerline of adjacent grooves shall be at least 1/16 in. plus the rope diameter.

(3) When a drum without grooves is used and single or multiple rope laying is employed, a level winding device shall be provided to maintain the rope in close wound, parallel lays.

7. Suspension Means and Their Attachment.-Scaffolds shall be suspended by steel wire ropes, with at least one rope supporting the scaffold at, or near, each end. When winding drums are located at the top of travel, the suspension rope fastenings shall be attached to the scaffold; when winding drums are located on the scaffold, the suspension rope fastenings shall be attached to supports at the top of travel; and when a hoist machine with a continuously rotating traction sheave is used at each end of the scaffold, the single suspension rope shall have at least 4 turns on the sheave for minimum lifting effect, and the rope length shall be equal to the total scaffold travel plus 8 ft. For each suspension rope, an adjacent safety suspension rope shall be provided. The safety suspension rope shall normally run free through a clamping device, that is part of the machine, and the clamping device shall be arranged to automatically grasp and hold the safety rope upon failure of the hoist rope.

(a) Only steel wire ropes with fiber cores, having the commercial classification "elevator wire rope" and of minimum grade "improved plow steel" shall be used for the suspension of scaffolds.

(b) Rope data tag information shall conform to the requirement of reference standard RS 18-1, rule 212.2b.

(c) The number of suspension ropes used, the diameter of the ropes, and the factor of safety shall conform to requirements of reference standard RS 18-1, rule 212.3.

(d) The minimum rope diameter shall be 5/16 in.

(e) Securing of wire rope to winding drums shall conform to requirements of reference standard RS 18-1, rule 212.6.

(f) At least 3 turns of rope shall remain on the winding drum when the scaffold is at the bottom of travel.

(g) Suspension wire ropes shall not be lengthened or repaired by splicing.

(h) Suspension wire rope fastenings at free ends shall conform to the requirements of reference standard RS 18-1, rules 212.9(a), (b), (c), (d), (e), and (f).

(i) Suspension ropes shall be provided with a rust-resistive coating.

(j) Reverse bends in the roping arrangement should be avoided. More than two reverse bends in each rope shall be prohibited.

(k) Means shall be provided to stabilize the suspension ropes to prevent sway and abrasion and, in all cases, such means shall be provided for every 300 ft. of scaffold travel.

8. Operating Devices and Control Equipment.-

(a) All electrical operating devices shall be of the constant

pressure or dead man type with weather proof enclosure. To prevent unauthorized use, the constant pressure device shall be key operated or protected by a padlock cover.

(b) All electrical equipment and wiring shall conform to the requirements of the electrical code of the city of New York.

(c) The normal operating devices for the vertical movement of the scaffold shall be located on the scaffold and shall be operable only when all electrical protective devices and interlocks on the scaffold are in position for normal service.

(d) The operating device of a power operated roof carriage for horizontal traversing shall be located on the roof carriage. This operating device shall be connected so that it will not be operable until the scaffold is raised to its uppermost position of travel and is disengaged from the building face or guiding rails on the building face and all protective devices and interlocks, on both the roof carriage or scaffold mounted hoist machine, are in position for traversing.

9. Traveling Cable.-

(a) Conductors for control, power, communication, signal, and ground may be run in a single traveling cable, provided that the cable conforms to the requirements of rule B30-166.0(i) of the electrical code of the city of New York.

(b) Traveling cables exceeding 100 ft. in length shall comply with rule B30-69.0 of the electrical code of the city of New York.

(c) The traveling cable shall be provided with a tensioning device to prevent uncontrolled cable sway, to protect the cable against abrasion, and to automatically prevent overtensioning of the cable. The tensioning device and cable drum shall be mounted in a weatherproof housing.

10. Electrical Protective Devices and Interlocks.-

(a) An overtensioning or tightrope device shall be connected into the drive motor circuit in a manner that will cause it to react to an overload and disconnect electric power to prevent upward pull on ropes if the scaffold becomes wedged in its tracks or is otherwise impeded while being raised.

(b) A slack rope device shall be provided that will react to a slackening of rope tension and disconnect electric power from drive motor to prevent the drum from overhauling the suspension rope if scaffold's downward motion is interrupted.

(c) Limit switches shall be provided at the top and bottom terminals of scaffold travel and shall be connected into the control circuits of the drive motors and actuated by cams at both ends of the scaffold and the roof carriage. Cam engagement of a limit switch at any travel terminal shall remove electric power from the motor circuit, and shall apply the brake to stop the scaffold or roof carriage.

(d) Hoist machine winding drums shall be provided with stop motion limit switches of the traveling nut type or equivalent. Such stop motion limit switches shall be connected to the drum shaft and set to open the operating circuit of the motors simultaneously with the cam operated

Reference Standard 18

final terminal travel limit switches.

(e) All electrical mounting boxes, conduits, piping, and junction boxes, and the controller frame, hoist machinery frame, roof carriage track system, and scaffold shall have a ground connection through a ground wire in the scaffold traveling cable and by a third rail contact or cable with a tensioning device for the roof carriage.

11. Power Supply System.-Electrical equipment and wiring for the power supply system shall conform to the applicable requirements of the electrical code of the city of New York.

12. Emergency Communication with Men on Scaffold.-Communication equipment shall be provided for each power operated scaffold to facilitate rescue operations in an emergency and shall consist of either:

(a) A telephone instrument mounted on the scaffold and connected through wires in the traveling cable to a manned instrument in the building and, in addition, a battery or hand operated air horn or other signalling device not requiring electricity to operate.

(b) A two-way radio telephone system with the receiving instrument in the building constantly manned during the operation of the scaffold and in addition, a battery or hand operated air born or other signalling device not requiring electricity to operate.

13. Special Maintenance.-

(a) Suspension ropes shall be examined, lubricated, and shackled or reshackled to conform to ANSI A17.2-1979

(b) Control mechanisms, switch panels, relay panels, and similar electrical operating equipment shall be examined and maintained to conform to ANSI A17.2-1979

(c) A continuous record of modifications and changes of equipment shall be kept on the premises for inspection and review by the commissioner.

(d) A complete and continuous record of operations shall be maintained, in which shall be recorded, regular maintenance procedures, and malfunctions, repairs, and emergencies.

**1156-80 BCR*

****REFERENCE STANDARD RS 18-9**

ANSI/ASME A90.1 1985-Safety Standards for Belt Manlifts.

***Local Law 65-1969; 11-91BCR; 1156-80BCR*

*****REFERENCE STANDARD RS 18-10 AMUSEMENT DEVICES**

*** TABLE OF CONTENTS**

Section Subject

PART I GENERAL PROVISIONS

- 1.0 Purpose, Intent and General Requirements
- 2.0 Scope and Application
- 3.0 Definitions
- 4.0 Compliance

- 5.0 Periodic Inspection and Test Intervals
- 5.1 Inspection and Test Requirements
- *5.2 Operation, Maintenance, Inspection and Test Records

PART II DESIGN AND CONSTRUCTION

- 6.0 Design
- *6.1 Amusement Device Entry and Discharge
- 6.2 Means of Access and Egress
- 6.3 Emergency Brakes and Anti-Roll Back Devices
- 6.4 Signal System
- 6.5 Protection Against Moving Parts
- 6.6 Speed Limiting Devices
- 6.7 Passenger-carrying Devices
- 6.8 Passenger Tramways
- 6.9 Electrical Equipment
- 6.10 Air Compressors and Equipment
- 6.11 Fire Prevention
- 6.12 Load Tests
- 6.13 Identification and rating Plates
- *6.14 Assembly and Disassembly
- *6.15 Lighting

PART III OPERATION

- 7.0 Notice
- 7.1 Daily Inspection and Test
- *7.2 Location of Controls
- *7.3 Control of Operation
- *7.4 Overload and Overspeed
- *7.5 Wind and Storm Hazards
- *7.6 Imminent Danger
- *7.7 Cleanliness
- *7.8 Passenger Conduct
- *7.9 Warning Signs

PART IV BUILDINGS AND STRUCTURES THAT ARE A FUNCTIONAL PART OF AN AMUSEMENT DEVICE

- 8.0 Scope
- 8.1 Construction
- 8.2 Occupant Safety

PART V ENCLOSED BUILDINGS AND STRUCTURES WHICH IN THEIR ENTIRETY CONSTITUTE THE AMUSEMENT DEVICE

- 9.0 Scope
- 9.1 Construction
- 9.2 Occupant Safety

PART VI PHYSICAL INFORMATION TO BE PROVIDED FOR AMUSEMENT DEVICES

- 10.0 Scope
- 10.1 Significance and Use
- 10.2 Information Requirement**

Reference Standard 18

TEXT

PART I GENERAL PROVISIONS

*1.0 PURPOSE, INTENT AND GENERAL REQUIREMENTS.

The purpose of this Reference Standard is to supplement the provisions of Subchapter 18 of Chapter 1, Title 27 of the Administrative Code of the City of New York "(Code)," entitled Elevators and Conveyors pertaining to the inspectional and test requirements for amusement devices and to establish the minimum safety requirements for, and control of the design, construction, installation, alteration, maintenance and operation.

***2.0 SCOPE AND APPLICATION.** These Reference Standards shall be applicable to all amusement devices operated within the City of New York whether located on a permanent, temporary, or mobile foundation. See Section 643 of the New York City Charter.

2.1 This Standard shall not apply to:

2.1.1 Any single passenger manually, mechanically or electrically operated, coin-operated device which is customarily placed, singly or in groups, in a public location and which does not normally require the supervision or services of an operator; and

2.1.2 Locomotives weighing more than seven tons, operating on track the length of which is 0 mile or greater, the gage of which is three feet or greater, and the weight is at 60 pounds per yard; and

2.1.3 Mobile type devices, self-contained and mounted on a motor vehicle or trailer not requiring further assembly or support, shall not be subject to this standard.

***3.0 DEFINITIONS.** These definitions are in addition to those set forth in the Code §27-232.

***3.1 ACCIDENT.** See Code §27-1006. An injury to any person requiring the services of a physician or damage to property or to apparatus exceeding \$100.

***3.2 AMUSEMENT DEVICE.** A mechanically operated device or structure, open to the public, used to convey persons in any direction as a form of amusement. For the purpose of these reference standards, the word mechanically shall read mechanically and/or electrically operated.

3.3 AMUSEMENT DEVICE FOR CHILDREN. An amusement device designed for children twelve years of age and under.

3.4 CHILD. A person 12 years of age and under.

3.5 CONTAINING DEVICE. A strap, belt, bar, gate or other safety device designed to prevent accidental or inadvertent dislodgement of a passenger from a device but which does not actually provide physical support.

3.6 DEVICE OPERATOR. Any person or persons actually engaged in or directly controlling the operations of an amusement device.

3.7 GUARDIAN. A person 16 years of age and over.

3.8 GUARDIAN RESTRICTION. A condition placed on an amusement device where a passenger must be accompanied on the device by a guardian.

3.9 HEIGHT RESTRICTION. A statute requirement for passengers to be permitted on a specific amusement device which is contained on the list of height restrictions maintained by the Commissioner in accordance with subsection 4.6 of this Standard.

3.10 NATIONALLY RECOGNIZED TESTING AGENCY. A laboratory, such as the Underwriters Laboratories, Inc., or the Factory Mutual Engineering Corporation or any similar testing organization acceptable to the Commissioner.

***3.11 NON-DESTRUCTIVE TESTING.** A general term used to identify inspection methods that permit evaluation of welds, structural members and joints without destroying their usefulness.

***3.12 OPERATOR.** A competent individual designated by the owner, who shall be at least 18 years old, free from serious physical or mental defects, selected with consideration of his abilities to perform his duties on an amusement device, in a careful and competent manner, who has met the requirements for a Certificate of Competency set forth under Policy and Procedure Notice #3 of 1993 in accordance with Code §27-1005.

***3.13 OWNER.** A person having legal title to the premises; a mortgagee or vendee in possession; a trustee in bankruptcy; a receiver or any other person having legal ownership or control of premises. For the purpose of these reference standards, the word premises shall read premises and/or amusement device.

***3.13.1 OWNER.** Also the person who manages the operations of the amusement device.

***3.14 PASSENGER TRAMWAY.** A device used to transport passengers in cars on tracks or suspended in the air, by use of steel cables, chains or belts or by ropes, and usually supported by trestles or towers with one or more spans.

***3.15 PERMANENT.** Lasting for a period of time exceeding two (2) weeks.

***3.16 PORTABLE.** Devices which by mounting on a motor vehicle or trailer are made mobile and which require additional assembly or support for operation. Their usage may be permanent or temporary.

***3.17 RESTRAINING DEVICE.** A safety belt, harness, chair, bar or other device which affords actual physical support, retention or restraint to the passenger of an amusement device.

***3.18 SHALL.** A mandatory requirement.

***3.19 STRUCTURE.** An assembly of materials forming a construction for occupancy or use, including among others: buildings, stadia, tents, reviewing stands, platforms, stagings, observation towers, radio towers, tanks, trestles, open sheds, coal pockets, shelters, fences and display signs.

***3.20 TEMPORARY.** Lasting for a period of time not to exceed two (2) weeks.

***4.0 COMPLIANCE.** Every owner, device operator and the public using an amusement device shall comply with or effect compliance with all provisions of applicable sections of the New York City Administrative Code and these reference standards.

Reference Standard 18

*4.1 An amusement device which is not in compliance with these reference standards shall not be used or occupied, except as provided in 4.2.

*4.2 Where only individual units or a device, such as cars, seats or other carriers are defective and not in compliance with these reference standards, such units shall be taken out of service and clearly marked with a sign reading Out of Service provided however, such defects do not jeopardize the safety of the entire device.

4.3 The owner of an amusement device shall not permit a person who in the judgement of the operator of the ride appears to be under the influence of alcohol or narcotics to enter any amusement device.

4.4 The Commissioner shall classify all amusement devices either an "Amusement Device" or as an "Amusement Device for Children."

4.5 The Commissioner shall reserve the right to establish the height restriction, guardian restriction, and classification of any device.

4.6 The Commissioner in accordance with subsection 4.5 of this section shall maintain a list of approved heights for children 12 years of age and under for specific amusement devices other than those designed for them.

4.7 The owner of an amusement device shall not permit a passenger under the approved height on such list; or

4.7.1 The passenger being a child not meeting the approved height restriction, is accompanied, elbow to elbow or front to back on the ride by a guardian.

*5.0 PERIODIC INSPECTION AND TEST INTERVALS. Every new and existing amusement device shall be inspected and tested in accordance with the provision of Code §27-998.

5.0.1 An amusement device may be used and operated for a period not to exceed six (6) months from the date of the last satisfactory periodic inspection and test, unless otherwise noted. The Commissioner may extend the periodic inspection and test for an additional two (2) months for amusement devices located in premises which are seasonably operated.

5.0.1.1 An amusement device which has been assembled and disassembled shall be inspected and tested as required by the Department after reassembly prior to its use and operation, regardless of the date of the previous inspection and tests. However, for portable devices, a prior load test inspection certificate from a cognizant state or city agency coupled with an affidavit that the test set-up is representative of the permitted operating conditions at the site based on said test may be accepted. The affidavit shall also state that all of the work necessary to retain it in the same structural situation has been performed.

5.0.1.2 An amusement device which has been altered, based upon an approved application and permit issued by the department, shall be inspected and tested.

5.0.1.3 An amusement device which has been relocated shall be inspected and tested after each relocation, as required by the department, prior to its use and operation, regardless of the date of the previous inspection and tests. However, for portable devices, a prior load test inspection certificate from a cognizant state or city agency coupled with an affidavit that

the test set-up is representative of the permitted operating conditions at the site based on said test, may be accepted. The affidavit shall also state that all of the work necessary to retain it in the same structural situation has been performed.

5.0.1.4 An amusement device shall be inspected and tested, regardless of the date of the previous inspection and tests, when there are reasonable grounds to believe that such tests are necessary to assure safety and the commissioner or his representative orders such tests to be made.

*5.0.1.5 All permanent amusement devices requiring a load test and which operate seasonally for less than nine months shall require two field inspections by authorized representatives of the Department. The first inspection shall take place prior to the opening day of the amusement device and the second inspection shall take place no sooner than 90 days nor later than 120 days from the first inspection.

5.0.2 Notification of the proposed date of the regular periodic inspection and test shall be made to the department at least one week prior to the scheduled date by the owner of the amusement device or by the person or firm conducting the inspection and test.

*5.0.3 Refer to Code §26-213c for required fees for inspection and tests, and for permits to use and operate amusement devices.

*5.1 INSPECTION AND TEST REQUIREMENTS. Every new and altered, rebuilt or modified amusement device shall be subjected to inspection and test requirements in accordance with the provisions of Code §27-999(c) and these reference standards.

5.1.1 Such inspections and tests shall be conducted by the person or firm installing, assembling, altering or relocating the amusement device and shall be witnessed by an authorized representative of the commissioner.

5.1.2 The results of the inspection and test for each amusement device shall be filed together with the required fee with the department by the person or firm conducting the inspection and tests. All such reports shall contain the following:

*5.1.2.1 The name, address and signature of the person conducting the inspection and test. All applications, plans, reports which are required to be submitted by a licensed Professional Engineer ("PE") or Registered Architect ("RA") shall be signed and sealed.

5.1.2.2 Trade or descriptive name of the amusement device and model number, if any, together with any identifying numbers.

5.1.2.3 The name and address of the manufacturer.

5.1.2.4 The date of the inspection and tests.

5.1.2.5 The maximum safe number of passengers and the maximum safe speed.

5.1.2.6 The results of the inspection and tests and a statement whether the results indicate confirmation as to the adequacy of the amusement device.

5.1.2.7 The results of the air compressor tank test and a statement whether the results indicate compliance.

* 5.1.2.8 There shall be kept with all permanent amusement

Reference Standard 18

devices requiring a load test, a maintenance or operational manual containing the recommended foundations. If the manual does not contain the required foundations, then a plan and design of the footings prepared by a PE or RA licensed in the State of New York shall be prepared and retained with the device. Said plan shall indicate the size and pressure under the footings and allowable soil bearing capacity. In the case of existing permanent amusement devices with a device number issued by the Department of Buildings, compliance with this requirement will be delayed until March 1, 1997, provided an affidavit is submitted by the owner of the amusement device to the Department prior to June 30, 1996 indicating the name of the PE or RA retained to prepare the plans.

* 5.1.2.9 For the installation of temporary amusement devices requiring a load test, the owner of the amusement device shall submit the proposed foundations as recommended in the maintenance or operational manual of the amusement device to the Department of Consumer Affairs together with any amusement device license application. If the manual does not contain the proposed footings for varying underlying conditions, a plan and design of the footings shall be submitted to the Department of Consumer Affairs prepared by a PE or RA licensed in the State of New York. The plan shall indicate the size and pressure under the footings and allowable soil bearing capacities and a copy shall be kept with the amusement device. A valid New York State "Permit to Operate an Amusement Device" may be submitted in lieu of the above.

*5.1.2.10 The name and signature of the authorized representative of the commissioner who has witnessed the inspection and tests.

*5.2.1 OPERATION, MAINTENANCE, INSPECTION AND TEST RECORDS Effective March 15 1997, the owner shall retain on-site for the preceding one year, current operation maintenance inspection and test records for each amusement device which is available to and acceptable to the Commissioner. Such records shall be kept up to-date at all times.

*5.2.1.1 All operations, maintenance, inspection and tests shall be performed in accordance with the manufacturer's manuals. Where such manuals are not available a PE or RA licensed in any jurisdiction acceptable to the Commissioner shall determine the necessary operation, maintenance, inspections and tests. Such manuals shall be prepared in accordance with ASTM F770-88, F846-92 AND F853-91. In the case of existing permanent amusement devices with a device number issued by the Department of Buildings, compliance with this requirement will be delayed until March 1, 1997 provided an affidavit is submitted by the owner of the amusement device to the Department prior to June 30, 1996 indicating the name of the PE or RA retained to prepare the manuals.

*5.2.1.2 For temporary amusement devices the owner shall submit to the Department of Consumer Affairs, together with the amusement device license application, an affidavit in a form acceptable to the Commissioner that all necessary operation, maintenance, inspection and tests required by the

manufacturer or the PE or RA pursuant to Section 5.2.1.1 have been performed for three (3) months prior to its present location. The affidavit shall contain the locations and dates of operation, maintenance, inspection and tests for the required 3 month period.

5.2.2 These records shall contain the following information:

* 5.2.2.1 Date and nature of all inspections whether by the Department or the owner.

5.2.2.2 Any violation and type of action taken to rectify the violation.

*5.3 NONDESTRUCTIVE TESTING FOR PERMANENT DEVICES REQUIRING A LOAD TEST.

* 5.3.1 All permanent amusement devices requiring load tests shall be inspected annually prior to the start of the season by nondestructive methods by a laboratory under the supervision of a PE or RA licensed in the State of New York or by authorized representatives of the manufacturer. The tests shall be performed in accordance with ASTM 3.03 (1995) Standards for Nondestructive Testing.

* 5.3.1.1 All personnel performing nondestructive tests shall be qualified by experience, education and examination in accordance with ASNT December 1992. SNT-TC-1A for Level II.

* 5.3.1.2 Prior to performing any tests the entire amusement device and supporting structure shall be visually inspected. The inspection of the amusement device shall be in the disassembled configuration where possible, in order to be able to inspect critical areas which cannot be seen or reached in the assembled configuration.

* 5.3.1.3 The parts of the amusement device and supporting structure subject to nondestructive testing shall be as recommended by the manufacturer. Where the manufacturer's recommendations are not available a PE or RA shall determine the parts of the amusement device and supporting structure which shall be tested in accordance with ASTM F846-92 and shall select the appropriate test method.

* 5.3.1.4 The laboratory or authorized representative of the manufacturer shall submit a test report to the Department of Consumer Affairs together with any amusement device license application and shall identify the ride tested, the Department of Consumer Affairs license number and the location of the tested areas. If the manufacturer or the PE or RA does not recommend any nondestructive testing then an affidavit reflecting such recommendation shall be submitted by the owner with evidence acceptable to the Commissioner of Buildings.

* 5.3.1.5 A weld that fails inspection shall be reported to the Department and shall be repaired by a licensed New York City welder. Where the welding work is not performed in the City of New York, welds shall be made by AWS qualified welders. A part such as a pin, axle or tension strap that fails inspection shall be removed and a new or repaired part shall be used as a replacement. The location of failed joints and parts shall be noted on the report to the Department. No amusement device shall be placed into operation until necessary repairs are made and the repaired parts retested.

Reference Standard 18

*5.4 NONDESTRUCTIVE TESTING FOR TEMPORARY DEVICES REQUIRING A LOAD TEST.

*5.4.1 The requirements set forth in Section 5.3 shall be applicable to temporary amusement devices

except that all temporary amusement devices requiring load tests shall have had a nondestructive test within one year prior to use of the amusement device in New York City. For temporary rides a valid New York State "Permit to Operate an Amusement Device" may be submitted in lieu of the affidavit referenced in Section 5.2.1.2 as evidence of compliance with nondestructive testing.

*5.4.1.1 In addition, the requirements set forth in Section 5.3 may be met by a licensed PE or RA of any jurisdiction acceptable to the Commissioner.

*5.5 The Commissioner may waive the requirements of Section 5.3 for a period not to extend beyond December 31, 1996 for existing permanent amusement devices with a device number issued by the Department of Buildings and the manufacturer's manuals are not available.

PART II DESIGN AND CONSTRUCTION

6.0 DESIGN.

6.0.1 All structures used in connection with amusement shall be so designated and constructed as to carry safely all loads to which such structures may normally be subjected.

*6.0.2 All amusement devices shall be designed, constructed and installed so as to withstand any normal stresses to which they may be subjected.

*6.0.3 Before being used by the public, amusement devices shall be so placed or secured with blocking, cribbing, outriggers, guys or other means as to be stable under all operating conditions.

*6.0.4 All amusement devices, such as, but not limited to, passenger tramways, where restoration of electrical power could create a hazard, shall be provided with a main disconnect switch capable of being locked only in the Off position.

*6.0.5 The path of travel of an amusement device shall have a clearance adequate to insure that a passenger on the device cannot be injured by contacting any structural member or other fixed object when the passenger is in the riding position.

*6.0.6 For any new amusement devices manufactured after January 1, 1997, or whenever any additions or alterations are made to any amusement device after January 1, 1997 which changes the structure, mechanism or capacity of any amusement device which requires a load test, a PE or RA shall submit signed and sealed plans of the amusement device to the Department and shall contain design data, safety factors, materials utilized, stress analysis and other pertinent data. The Department's review and acceptance of said plans shall be conveyed by the owner to the Department of Consumer Affairs. The owner shall indicate on its application for an amusement device license whether the device was manufactured or altered after January 1, 1997.

*6.0.6.1 Such stress analysis shall include the affect of

forces generated by acceleration, deceleration, centrifugal action or kinetic or other forces which are constant, reversible or eccentric. Materials and other data pertinent to the design, structure, factors of safety or performance characteristics shall be in accordance with accepted engineering practices, standards and specifications acceptable to the Department, and written in English.

*6.0.6.2 Such plans, dimensioned to scale, shall identify parts and components of amusement devices including, but not limited to the following:

- *6.0.6.2.1 Bars
- *6.0.6.2.2 Cables
- *6.0.6.2.3 Chains
- *6.0.6.2.4 Ropes
- *6.0.6.2.5 Rods
- *6.0.6.2.6 Pipes
- *6.0.6.2.7 Girders
- *6.0.6.2.8 Braces
- *6.0.6.2.9 Fittings
- *6.0.6.2.10 Fasteners
- *6.0.6.2.11 Trusses
- *6.0.6.2.12 Pressure vessels
- *6.0.6.2.13 Pressure piping
- *6.0.6.2.14 Gears
- *6.0.6.2.15 Clutches
- *6.0.6.2.16 Speed reducers
- *6.0.6.2.17 Welds
- *6.0.6.2.18 Bearings
- *6.0.6.2.19 Couplings
- *6.0.6.2.20 Shaftings
- *6.0.6.2.21 Carriers, such as tubs, cars, chairs, gondolas, or seating and carrying apparatus of any description
- *6.0.6.2.22 Axles
- *6.0.6.2.23 Hangers
- *6.0.6.2.24 Pivots
- *6.0.6.2.25 Safety bars, belts, harnesses, chains, gates or other restraining, containing, or retaining devices

*6.1 MUSEMENT DEVICE ENTRY AND DISCHARGE. Safe and adequate means of entry and discharge from each device shall be provided. This safe and adequate means of entry and discharge shall not be construed to means of exits, means of access, means of egress.

6.2 MEANS OF ACCESS AND EGRESS.

*6.2.1 Safe and adequate means of access and egress from amusement devices shall be provided.

*6.2.2 At least two means of egress remote from each other shall be provided from each floor, tier, room or balcony in structures which house amusement devices.

6.2.3 Access to the means of egress shall be marked by readily visible signs in all cases where it is not immediately visible to the passengers.

6.2.4 No means of egress shall be less than 22 inches in width.

6.2.5 The width of a stairway shall be taken as the length of the treads between stringers. The width of a doorway shall be taken as the width of the door.

6.2.6 The maximum travel distance from the most remote

Reference Standard 18

point in any room or enclosed space to an open safe outside space shall be not greater than that listed below:

6.2.6.1 100 feet in unsprinklered construction,

6.2.6.2 150 feet in sprinklered construction, and

6.2.6.3 25 feet in dead ends.

6.2.7 Means of access and egress shall have protection from adjacent hazards and protection from falling by use of rails, enclosures, barriers or similar means.

6.2.8 Means of access and egress shall be free from debris, obstructions, projections and slipping, tripping and other hazards.

6.2.9 The head clearance in passageways shall not be less than 7 feet.

*6.2.10 Means of access or egress shall have either stairways or ramps and connecting landings or platforms where the public enter or leave an amusement device, that is above or below grade with proper handrails and guards.

6.2.11 Stairways, passageways, ramps, landings or platforms shall be not less than 22 inches in width for single lane passage or 44 inches for double lane passage. Landings or platforms shall not be less than 3 feet long measured in the direction of travel.

*6.2.12 Stair treads shall be at least nine inches deep exclusive of nosing and the height of rise shall not exceed eight inches. Between any two connecting levels the treads shall be of uniform depth and the risers shall be of uniform height. The slope of ramps shall not exceed that required in Code §27-377.

6.2.13 Substantial handrails shall be provided on both sides of all stairways of four or more risers connecting adjoining levels whose difference in elevation is 80 inches or more.

6.2.14 Substantial handrails shall be provided on both sides of landings, platforms or ramps 30 inches or more above grade.

6.2.15 Handrails shall be at least 30 inches above the ramp surface or nose of steps and 42 inches above the landings.

6.2.16 The distance between handrails shall not be less than 18 inches for single lane passage and 36 inches for double lane passage.

6.2.17 Two intermediate rails spaced equally apart or equivalent construction to prevent a passenger from falling through the handrails shall be provided with handrails.

6.2.18 Stairways and ramps requiring handrails in accordance with 6.2.13 or 6.2.14 which are more than 8 feet wide shall be provided with railings dividing the widths into not more than 8 feet and not less than the widths of 6.2.11.

6.2.19 Stairways, landings and ramps shall be designed, constructed and maintained so as to sustain safely a live load of at least 100 pounds per square foot.

*6.2.20 Surfaces in 6.2.19 shall be of non-slip type.

6.2.21 ILLUMINATION. Access to and exits from amusement devices, erected permanently or temporarily, shall be provided with illumination by natural or artificial means of not less than five (5) foot candles measured at grade level.

6.3 EMERGENCY BRAKES AND ANTI-ROLL BACK DEVICES.

*6.3.1 If cars or other components of an amusement device may collide upon failure of normal controls, emergency

brakes sufficient to prevent such collisions shall be provided.

*6.3.2 On devices which make use of inclined tracks, automatic anti-roll back devices shall be installed to prevent backward movement of the passenger-carrying units in case of failure of the propelling mechanism when such backward movement could result in injury to a member of the public.

6.4 SIGNAL SYSTEM.

*6.4.1 Signal systems for the starting and stopping of amusement device shall be provided where the operator of the device does not have a clear view of the point at which passengers are loaded or unloaded.

6.4.2 Any code of signals adopted for the operation of any amusement device shall be printed and kept posted at both the operators and signalman stations. All persons who may use these signals shall be carefully instructed in their use.

6.4.3 Signals for movement or operation of an amusement device shall not be given until all passengers and other persons who may be endangered are in a position of safety.

*6.5 PROTECTION AGAINST MOVING PARTS.

*6.5.1 An amusement device shall not be used or operated while any person is so located as to be endangered by it. Areas in which persons may be so endangered shall be fenced, barricaded or otherwise guarded against public intrusion.

6.5.2 Machinery used in or with an amusement device shall be enclosed, barricaded or otherwise effectively guarded against contact. Guards removed for maintenance purposes shall be replaced before normal operation is resumed. Maintenance shall not be conducted while in public use.

*6.6 SPEED LIMITING DEVICES. An amusement device capable of exceeding its maximum safe operating speed shall be provided with a maximum speed-limiting device which may be either electrical or mechanical.

6.7 PASSENGER-CARRYING DEVICES.

6.7.1 The interior and exterior parts of all passenger-carrying amusement devices with which a passenger may come in contact shall be smooth and rounded, free from sharp, rough or splintered edges and corners, with no protruding studs, bolts, screws or other projections which might cause injury.

*6.7.2 Interior parts upon which a passenger may be forcibly thrown by the action of the device shall be adequately padded.

6.7.3 Amusement devices equipped with a safety bar, cage or other mechanically operated restraining device shall be equipped with a retiring cam or other device so designed that the safety bar, cage or other mechanically operated device cannot be released except at the point of loading or unloading; or alternately that the release device is on the exterior of the conveyance, cab or vehicle and is normally actuated by the amusement device operator.

6.7.4 Amusement devices which are self-powered and which are operated by a passenger shall have the driving mechanism so guarded and the guards so secured in place as to prevent passengers from gaining access to the mechanism.

*6.7.5 Belts, bars, footrests and other equipment as may

Reference Standard 18

be necessary for safe entrance and exit and for support while the device is in operation shall be provided and maintained in a safe condition. Such equipment and the fastenings shall be of sufficient strength to retain the passengers.

6.7.6 Passenger restraining or containing devices shall be provided and used on any amusement device where centrifugal and other forces or mechanical malfunction could unseat or dislodge a passenger.

*6.7.7 Passenger restraining or containing devices used on tubs, cars, chairs, seats, gondolas and other carriers on an amusement device, where the forces generated by the action of the device require retention, restraint or actual physical support of the passenger shall be designed, constructed, installed, and maintained to support the passenger safely. The fastenings shall be a type which cannot be inadvertently released by the passenger or by an accidental means. Icebox fastenings on a scrambler will not meet this requirement.

6.7.8 Anchorages for the required restraining devices shall have strength at least equal to the strength of the restraining device.

6.8 PASSENGER TRAMWAYS.

6.8.1 The standards prescribed by safety requirements for Aerial Passenger Tramways ANSI B77.1-1982 and supplements B77.1a-86 and B77.1b-88 are adopted as safety standards and shall apply according to the provisions thereof.

6.8.2 Each operator engaged in passenger tramway operations shall protect the public by complying with the standards prescribed in 6.8.1.

6.8.3 Only technical standards relating to public safety are adopted by any incorporation by reference as prescribed in 6.8.1. Other standards relating to administration and reporting procedures are not adopted.

6.8.4 Where any conflict occurs between the standards prescribed in 6.8.1 and these rules, these rules shall prevail.

6.9 ELECTRICAL EQUIPMENT.

6.9.1 All electrical wiring and equipment used for amusement devices or for lighting shall be installed, operated and maintained in accordance with the New York City Electrical Code.

6.9.2 All electrical transformer substations shall be properly enclosed and proper warning signs shall be posted.

6.9.3 Electrical wiring and equipment located outdoors shall be of such quality and so constructed or protected that exposure to weather will not interfere with its normal operation.

6.9.4 Elevated power lines crossing access or other roads within the grounds of a carnival or amusement park shall be so suspended as to provide a vertical clearance of at least 14 feet from the road surface or 3 feet above any vehicle used within the grounds of a carnival or amusement park. A horizontal clearance of at least three feet shall be provided on each side of the normal passage space of vehicles.

6.9.5 All lamps for general illumination shall be protected from accidental contact or breakage. Protection shall be provided by elevation of at least 7

feet from normal working surface or by a suitable fixture or lampholder with a guard.

6.9.6 Each electrically powered amusement device shall be effectively grounded. The grounding shall be made effective as to all non-current carrying metal parts which may become energized and which are exposed to contact by any person.

6.9.7 PROTECTION OF EMPLOYEES. No employees shall be suffered or permitted to work in such proximity to any part of an electric power circuit that he may contact the same in the course of his work unless he is protected against shock by de-energizing the circuit, grounding it, or guarding it by effective insulation. If the protection is supplied by de-energizing the circuit, the switch controlling the circuit shall be locked out to prevent inadvertent closing.

6.10 AIR COMPRESSORS AND EQUIPMENT. Air compressors, air compressor tanks and equipment used in connection therein shall be designed, constructed, equipped and maintained to insure safe operation at all times. They shall be inspected and tested every six months by a qualified person. Air compressor tanks shall be tested to demonstrate that they will sustain a hydrostatic pressure for a period of at least one (1) hour. Such test shall be conducted at the same time as the required periodic inspection and test. A record of each inspection shall be kept and made available to the Commissioner. Air compressor tanks and other air receivers used in connection with air compressors shall have the maximum allowable working pressure conspicuously marked thereon. Refer to Rule 6.11.

6.11 FIRE PREVENTION. The New York City Fire Prevention Code shall be applicable to this section.

6.11.1 Fabrics constituting part of an amusement device shall be flame resistant to meet the following field test: The application of a flame from a three-quarter inch paraffin candle for a period of one minute which does not cause the fabric to flash, nor support combustion, nor continue to flame for more than two seconds or glow for more than thirty seconds after removal of the test flame.

6.11.2 Approved fire extinguishers shall be provided where necessary to secure reasonable and adequate protection from fire hazards.

6.11.3 Flammable waste such as oily rags and other flammable materials shall be placed in covered metal containers which shall be kept in easily accessible locations. Such containers shall not be kept at or near exit.

6.11.4 Gasoline and other flammable liquids and flammable gases when stored shall be kept in reasonably cool and ventilated places. Such liquids shall be in approved containers. Smoking and the carrying of lighted cigars, cigarettes or pipes is prohibited in any area where such liquids or gases are stored or are transferred from one container to another.

Reference Standard 18

6.12 LOAD TESTS.

6.12.1 No passenger-carrying amusement device of the following types shall be used or put into normal operation until it has withstood an annual load test without failure in any material respect:

6.12.1.1 Devices having suspended passenger seats or spaces;

6.12.1.2 Devices normally operated at speeds or with movements creating severe gravity, inertial or centrifugal forces;

6.12.1.3 Devices so elevated that structural failure is likely to cause passengers to be injured by falling;

6.12.1.4 Devices as to which the commissioner has ordered such a test upon finding it necessary to assure safety.

*6.12.2 Each passenger seat or space shall be weighted with at least 150 pounds dead weight, except that in a device intended only for small children, each seat or space shall be weighted with at least 75 pounds. While so loaded the device shall be operated at maximum normal speed as to test the full operation of all control devices, anti-rollback devices, speed limiting devices, brakes and other equipment provided for safety. The device shall withstand the test without failure in any material respect. The soil and the foundation shall not show signs of inadequacy.

6.12.3 Unless a load test is made in the presence of the Commissioner, the owner of the device shall cause to be filed with the Commissioner a statement by either (1) the manufacturer of the device, or (2) an insurance carrier lawfully doing business in this State and carrying public liability insurance on the device, or (3) a qualified Licensed PE or RA showing whether the device withstood the test without failure in any material respect and setting forth such other relevant information as the Commissioner may require. Until such a statement is so filed it shall be presumed that the device has not withstood the test as required.

6.12.4 A load test complying with 6.12.3 when performed in another jurisdiction shall be deemed acceptable, provided:

6.12.4.1 The statement required by 6.12.3 is substantially equivalent and the information therein is verified by a Licensed PE or RA.

6.12.4.2 The jurisdiction enforces rules substantially equivalent to this Section, and

6.12.4.3 A copy of the statement is furnished to the Commissioner.

6.12.5 If the device fails to withstand a load test it shall be deemed unsafe and shall not be used until and unless it has withstood a subsequent load test without failure in any material respect. If the device has withstood a load test without failure in any material respect, it shall be required to be so tested again before going into normal operation only if rebuilt or modified or if there are reasonable grounds to believe that a further test is necessary before the next required load test to assure safety and the Commissioner orders such test to be made.

6.13 IDENTIFICATION AND RATING PLATES.

*6.13.1 Every amusement device shall be identified by the name and address of the manufacturer, a trade or descriptive name and the physical information prescribed in Section 6.13 and in Part VI.

*6.13.2 A metal plate shall be affixed to the amusement device readily visible and legible at all times and shall contain the following information:

*6.13.2.1 Owner's name and address

*6.13.2.2 Department of Consumer Affairs license number

*6.13.2.3 Name of device

*6.13.2.4 Capacity of device

*6.13.2.5 Speed of device

*6.13.3 Information other than as required in Section 6.13.2 may be kept in an office on the same premises.

*6.13.4 If an amusement device or its supporting structure is altered or its name changed, or its capacity increased, or its speed increased, or its ownership changed, the metal plate shall be removed and a new metal plate with the correct information shall be affixed to the device.

*6.14 ASSEMBLY AND DISASSEMBLY.

*6.14.1 The assembly and disassembly of an amusement device shall be done by or under the immediate supervision of a person experienced and instrumental in the proper performance of such work in respect to the device or structure.

* 6.14.2 Assembly work shall be performed in a proper and workmanlike manner. Parts shall be properly aligned and shall not be bent, distorted, cut or otherwise injured to force a fit. Parts requiring lubrication shall be lubricated in course of assembly and as required during operation. Fastening and locking devices, such as bolts, cap screws, cotter pins and lock washers, shall be installed where required for safe operation. Nuts shall be drawn tight, cotter pins shall be spread and lock nuts firmly set. "R" pins shall only be used in locations recommended by the manufacturer or licensed PE or RA.

* 6.14.3 Parts which are excessively worn or which have been materially damaged shall not be used. Close visual inspection of parts shall be made during assembly to discover such wear or damage and immediate inspection of fastening devices shall be made after assembly to assure that they have been properly installed.

* 6.14.4 Persons engaged in the assembly or disassembly of amusement devices shall be provided with and shall use tools of proper size and design to enable the work to be done in a proper manner. Broken, damaged and unsuitable tools shall not be used.

* 6.14.5 Assembly and disassembly of amusement devices shall be done under light conditions sufficient to permit the work to be properly performed and inspected.

* 6.14.6 A sufficient number of persons to do the work properly shall be engaged for the assembly or disassembly of amusement devices. Persons not so engaged shall be prevented from entering the area in which the work may create a hazard.

Reference Standard 18

*6.14.7 The owner of an amusement device shall comply with the manufacturers construction manual for the assembly and disassembly of the device. The manufacturers construction manual shall be kept with the amusement device and shall be available for use by an authorized representative of the Department.

*6.15 LIGHTING.

*6.15 Amusement devices access thereto and means of egress therefrom shall, while in operation or occupied, be provided with illumination by natural or artificial means sufficient to guard against injuries to the public.

PART III OPERATION

7.0 NOTICE.

7.0.1 No amusement device shall be used at any time or location unless prior notice of intent to use the same has been given to the Commissioner.

*7.0.2 Notice of planned schedules shall (1) be in writing, (2) identify the device, (3) state the intended dates and locations of use, and (4) be given to the Department's Elevator Division and Bureau of Electrical Control at least five days before the first intended date of use.

7.1 DAILY INSPECTION AND TEST.

*7.1.1 In addition to the requirement set forth in Sections 5.0, 5.1 and 5.2 an amusement device shall be inspected and tested on each day before it is intended to be used. The inspection and test shall be made by a qualified person experienced and instructed in the proper assembly and operation of the device and shall be performed before the device is put into normal operation.

7.1.2 The inspection and test shall include the operation of control devices, speed-limiting devices, brakes and other equipment provided for safety.

*7.1.3 In addition to the requirements of 5.2.1. a record of each inspection and test shall be made at once, upon completion of the test, and shall be kept with the amusement device and available to the Commissioner or authorized representative for at least one year.

*7.2 LOCATION OF CONTROLS. Controls for the starting and stopping of amusement devices shall be so located that the operator of the device has a clear view of the point at which passengers are loaded and unloaded.

*7.3 CONTROL OF OPERATION. Amusement devices shall be operated only by designated competent operators who have secured a Certificate of Competence from the Commissioner in accordance with the provisions of Code §27-1005.

*7.3.1 The device operator shall operate no more than one device at any given time.

*7.3.2 The device operator shall have knowledge of the use and function of all normal and emergency operating controls and the proper use of the device.

*7.3.3 The device operator shall be in the immediate vicinity of the operating controls during operation and no other person shall be suffered or permitted to handle such controls during normal operations. This provision shall not apply to amusement devices designed to be operated or

controlled safely by a passenger.

*7.3.4 The device operator shall not operate any device when under the influence of alcohol or drugs.

*7.3.5 The device operator shall operate the device in accordance with the manufacturers operating manual. The manufacturers operating manual shall be kept with the amusement device or in an office on the same premises and shall be available for use by an authorized representative of the Department.

*7.3.6 The device operator shall lock-out the electrical disconnect switch when restoration of electrical power to amusement device could create a hazard to persons during the performance of maintenance, repair, inspection or an emergency evacuation of passengers, and insure that it retains lock-out until such time that restoration of power will not create hazard.

*7.4 OVERLOAD AND OVERSPEED.

*7.4.1 An amusement device shall not be overcrowded, or loaded in excess of its safe carrying capacity.

*7.4.2 An amusement device shall not be operated at an unsafe speed or at a speed beyond that recommended by the manufacturer.

*7.5 WIND AND STORM HAZARD. An amusement device which is exposed to wind or storm shall not be operated under dangerous conditions except to release or discharge occupants.

*7.6 UNSAFE. If the Commissioner finds that an amusement device presents an imminent danger, he may attach to said device an UNSAFE notice, warning all persons against the use of the device. Such notice shall not be removed until the device is made safe, and then only by a representative of the Commissioner. The device shall not be used during the time that the notice is attached.

*7.7 CLEANLINESS.

*7.7.1 A suitable number of metal containers shall be provided in and around amusement devices. Excessive accumulations of trash or refuse shall be promptly removed.

*7.7.2 All parts of amusement devices and temporary structures used by passengers or customers shall be maintained in a clean condition.

*7.8 PASSENGER CONDUCT.

*7.8.1 The owner shall have the right to refuse any member of the public admission to a device if his bearing or conduct will endanger himself or other members of the public.

*7.8.2 The owner shall have the right to refuse admittance to any device if the intended passengers health or physical condition makes it unsafe for him to use the device.

*7.8.3 The owner shall refuse a passenger seeking admission to an amusement device if the passenger cannot meet a guardian or height restriction if the device is subject to such a restriction. Legible signs to this effect shall be posted in full view of the public seeking admission to the amusement device. Refer to the requirements of the Department of Consumer Affairs.

*7.9 WARNING SIGNS.

*7.9.1 Where an amusement device exposes a passenger

Reference Standard 18

to high speed, substantial centrifugal force or a high degree of excitement, the owner shall post a conspicuous warning sign at the entrance to the device advising the public of the risk to passengers.

* 7.9.2 The sign required by 7.9.1 shall be at least 2 feet by 2 feet in sharply contrasting colors.

* 7.9.3 The sign required by 7.9.1 shall read as follows or express an equivalent warning.

The following people should not ride this amusement device:

1. Those under the influence of alcohol.
2. Those under influence of narcotics.
3. Those with heart conditions.
4. Pregnant women.
5. Handicapped people.
6. Those subject to motion sickness.
7. Those with back ailments.

* 7.9.4 The following additional signs may be required to be posted:

* 7.9.4.1 Passengers shall remain seated until device comes to complete halt!

* 7.9.4.2 No Standing!

* 7.9.4.3 No Smoking!

* 7.9.4.4 No Food or Drink!

PART IV. BUILDING AND STRUCTURES THAT ARE A FUNCTIONAL PART OF AN AMUSEMENT DEVICE.

8.0 SCOPE. This part shall apply to the construction of buildings and structures that are a functional part of an amusement device. To be a functional part of an amusement device, the building or structure shall be a contributing factor to the amusement, pleasure, thrill or excitement of the device.

8.1 CONSTRUCTION. Building Code Occupancy group classification, assembly, designation F-2, shall apply to buildings and structures constructed according to this part.

8.2 OCCUPANCY SAFETY. The following shall be provided in buildings and structures that are a functional part of an amusement device.

8.2.1 Posted signs indicating the number of persons who may safely occupy the space.

8.2.2 Illuminated exit signs in compliance with Article 6 of Subchapter 6 of the Code.

8.2.3 Not less than two fire extinguishers of a 10 pound ABC multi-purpose type approved by Underwriters Laboratory, Inc.

PART V. ENCLOSED BUILDINGS AND STRUCTURES WHICH IN THEIR ENTIRETY CONSTITUTE THE AMUSEMENT DEVICE.

9.0 SCOPE. This part shall apply to the construction of enclosed buildings and structures which in their entirety constitute the amusement device. It functions by

pedestrians passage (by persons and/or children) through the enclosed building or structure which activates devices which contribute to their pleasure, thrill or excitement.

9.1 CONSTRUCTION. Building Code occupancy group classification, assembly, designation F-3, shall apply to buildings and structures constructed according to this part. Fun houses and haunted houses are representative occupancies.

9.2. OCCUPANCY SAFETY. The following shall be provided in buildings and structures occupied in accordance with this part:

*9.2.1 A posted sign at a prominent entrance location of 4 inch high letters stating:

OCCUPANCY BY MORE THAN 75 PERSONS IS UNLAWFUL.

9.2.2 A posted sign at a prominent entrance location stating:

NO SMOKING OR OPEN FLAME.

*9.2.3 Illuminated exit signs in compliance with Article 6 of Subchapter 6 of the Code.

*9.2.4 Automatic Fire Detectors in compliance with reference standards RS 17-3 and RS 17-5E. Closed circuit supervised detectors shall be installed in accordance with the above referenced standards.

9.2.4.1 Closed circuit supervised means all detector loops are complete. Should a break occur in the loop wiring, a trouble signal will sound at the control panel.

*9.2.5 Emergency lighting in compliance with Code §27-542; and activated at the same time as the automatic fire detection system.

9.2.6 Not less than two fire extinguishers of a 10 pound ABC multi-purpose type approved by Underwriters Laboratory, Inc.

PART VI. PHYSICAL INFORMATION TO BE PROVIDED FOR AMUSEMENT DEVICES.

10.0 SCOPE.

*10.0.1 ANSI/ASTM F698-1988. Standard Specification for Physical Information to be provided for Amusement Devices, as modified.

*10.0.2 The specification in section 10.1 covers the minimum requirements for information regarding amusement devices that shall be provided to the end user by the manufacturer or seller of amusement devices.

***10.1 SIGNIFICANCE AND USE.**

*10.1.1 The purpose of this specification is to provide the minimum information necessary for the proper identification, placement, erection and operation of each amusement device.

***10.2 INFORMATION REQUIREMENTS.**

*10.2.1 The information in sections 3.2 to 3.16 shall be either included or indicated as not applicable for all amusement devices by the manufacturer or seller at the time of sale of such amusement device.

***10.2.2 DEVICE SERIAL NUMBER.**

A manufacturers issued unique identifying number or code affixed to the device in a permanent fashion.

Reference Standard 18

*10.2.3 DEVICE MODEL NUMBER. A manufacturer's unique identifying number or code assigned to each manufactured type of device having the same structural design or components.

*10.2.4 DATE OF MANUFACTURE. The date (month and year) determined by the manufacturer that the given device met his required construction specifications.

*10.2.5 TRAILERING INFORMATION. Each trailer necessary for the transport of a portable amusement device shall be provided with the following information: height, width, length and weight.

10.2.6 STATIC INFORMATION. The following information shall be provided for the amusement device when it is in a non-operational state with no passengers: height, width, diameter and weight.

10.2.7 DEVICE SPEED.

*10.2.7.1 Maximum revolutions per minute, or

*10.2.7.2. Maximum feet per second or miles per hour.

*10.2.8 DIRECTION OF TRAVEL. When the proper direction of travel is essential to the design operation of the device, the manufacturer shall designate the direction of travel, including reference point for this designation.

*10.2.9 POWER REQUIREMENTS.

*10.2.9.1 ELECTRICAL. Total electrical power required to operate the device designated in watts, volts and amperes, including minimum and maximum voltage limits.

*10.2.9.2 MECHANICAL. Minimum horsepower necessary to operate the device properly.

*10.2.10 LOAD DISTRIBUTION PER FOOTING.

*10.2.10.1 Maximum static loading of each footing of an amusement device, and

*10.2.10.2 Maximum dynamic loading of each footing of an amusement device.

*10.2.11 PASSENGER CAPACITY.

*10.2.11.1 Maximum total passenger weight, and

*10.2.11.2 Maximum number of passengers.

*10.2.12 RIDE DURATION. The actual time the ride is in operation or a passenger is exposed to the elements of the device functions, including passenger restrictions to maximum exposure time shall be included.

*10.2.13 RECOMMENDED BALANCE OF PASSENGER LOADING OR UNLOADING.

When passenger distribution is essential to the proper operation of the device, the appropriate loading and unloading procedure, with respect to weight distribution shall be provided.

*10.2.14 RECOMMENDED PASSENGER RESTRICTIONS.

Where applicable, any recommended passenger limitations such as, but not limited to, height, weight, age, passenger placement, or any other appropriate restrictions.

*10.2.15 ENVIRONMENTAL RESTRICTIONS.

Recommendations for operational restrictions relating to environmental conditions such as, but not limited to, wind, rain, salt corrosion, and extreme heat or cold.

*** 11-91 BCR; 934-84 BCR

*DOB 3-8-96



REFERENCE STANDARD RS-19
SAFETY OF PUBLIC AND PROPERTY DURING CONSTRUCTION OPERATIONS

* **LIST OF REFERENCED NATIONAL STANDARDS**

| | | |
|----------------|--|------|
| ANSI A10.3 | Power Actuated Fastening Systems- Safety Requirements, as Modified..... | 1985 |
| ANSI A10.11 | American national standard for personnel and debris nets used during construction, repair and demolition operations, as modified. | 1989 |
| **ANSI B30.5 | Mobile and Locomotive Cranes - Chapter 5-1 except Section 5-1.9.9 | 2000 |
| **ANSI B30.5 | Mobile and Locomotive Cranes - Chapter 5-1 except Section 5-1.9.9 | 1994 |
| **ANSI B30.5 | Mobile and Locomotive Cranes - Chapter 5-1 except Section 5-1.9.9 | 1989 |
| **ANSI B30.5 | Mobile and Locomotive Cranes - Chapter 5-1 except Section 5-1.9.9 | 1982 |
| **ANSI B30.5 | Mobile and Locomotive Cranes - Chapter 5-1 except Section 5-1.9.9 | 2004 |
| **ANSI B30.5 | Mobile and Locomotive Cranes | 1968 |
| **CEN EN 13000 | Cranes –Mobile Cranes, except Section 4.2.6 | 2004 |

*Local Law 61-1987; 111-90 BCR; 234-90 BCR; 1155-80 BCR

**DOB 10/1/06

** **REFERENCE STANDARD RS 19-1**

ANSI A10.3 1985-Power-Actuated Fastening Systems-Safety Requirements, as Modified.

Modifications.-The provisions of ANSI A10.3-1985 shall be subject to the following modifications. The section numbers are from that standard.

Amend section 4.2.2.1 to read as follows:

4.2.2.1 Medium-velocity tools, indirect-acting (piston) type, as defined in section 3, shall (meet the requirements of 4.1) not be accepted.

Delete sections 4.2.2.2, 4.2.2.3 and 4.2.2.4.

Amend section 4.2.3.1 to read as follows:

†4.3.2.1. High velocity tools, direct-acting or indirect-acting type, as defined in section 3, shall (meet the requirements of 4.1) not be accepted.

Delete sections 4.2.3.2, 4.2.3.3 and 4.2.3.4.

‡As enacted, but "4.2.3.1" probably intended

Add the following new section:

5.6 Selection of load.-No employer shall knowingly furnish to an employee for use in a tool any cartridge or load not suitable for safe use in that tool, whether by reason of excessive power, improper design or poor material. The operator shall use due care to select the proper cartridges or power loads, or other means of controlling the force of the explosion so that it develops no more than the necessary pressure to bring about the desired penetration. In doing so, the operator shall be guided by the manufacturer's specifications.

5.6.1 Proper Load.-When doubt exists (as to proper load), the operator shall make a trial shot to test the surface and the strength of the material to be penetrated. The trial shot shall be made with the lowest power level and then increasing strength until a proper fastening is made. During this test, the operator and all bystanders shall adhere to all safety rules including, but not limited to wearing goggles and hard hats required for the job.

Add the following sentence before the first sentence in section 7.10:

7.10 The operator shall always verify the thickness and type of material into which the stud, pin or fastener is to be driven.

Add the following sections:

9.4 Storage of power loads shall be in accordance with the requirements of Fire Prevention Directive 2-62 R, dated February 21, 1979, Division of Fire Prevention, entitled "Regulations Governing the Use and Storage of Ammunition for the Construction and Alteration of Buildings."

10.3.1 The authorized instructors' card shall list the specific model(s) of powder actuated tool(s) for which training may be given.

10.6 All authorized instructors shall hold a Certificate of Fitness issued by the Fire Department.

11.4.1 The qualified operator's card shall list the specific model(s) of powder actuated tool(s) which may be used.

11.6 All qualified operators shall hold a Certificate of Fitness issued by the Fire Department.

12. Materials and Equipment Acceptance Division.

12.1. Powder-actuated tools using ammunition (power loads) accepted by the Materials and Equipment Acceptance Division and shall be accompanied by such a label.

12.2 Labeling.-The MEA acceptance label may be attached to the tool box or to the operator's manual in lieu of attaching it to the tool but, in any event must be kept available for inspection.

13. Fire Department Requirements.

13.1 The requirements of Fire Department, Division of Fire Prevention, Directive 2-62 R, dated February 21, 1979, entitled "Amended Regulations Governing the Use and Storage of Ammunition for the Construction and Alterations of Buildings" shall be complied with.

13.1.1. The following is extracted from such regulations:

a. Powder actuated tools utilizing ammunition (power loads) shall be used only by a person holding a

Reference Standard 19

Certificate of Fitness issued by the Fire Department upon a submission of evidence that person has satisfactorily completed a training program in the safe use of such equipment, acceptable to the Fire Department.

b. No powder actuated tool utilizing ammunition (power loads) shall be used unless the Certificate of Fitness holder establishes a safe zone behind the work area by the use of a one-quarter inch steel back-up plate and/or maintenance of an area clear of all people.

**111-90 BCR

***RS 19-2 POWER OPERATED CRANES AND DERRICKS

1.0 Scope.-This standard applies to the construction, installation, inspection, maintenance and use of power operated cranes and derricks used for hoisting and/or rigging purposes; or used for the construction, alteration, demolition, excavation and maintenance purposes, including highways or sewers; or used for the installation of piles; or used for the hoisting or lowering of any article on the outside of any building or structure.

1.1 Exemptions.-Exempt from the requirements of this reference standard are the following:

1.1.1 Cranes or derricks used in industrial or commercial plants or yards and floating cranes, floating derricks and cranes and derricks used on floating equipment. Also augers, churn-drills and other drilling equipment. Operators of such equipment shall be exempt from any licensing requirements.

1.1.2 Operators of cranes described in section C26-1909.4(a)(3) and (4) of the administrative code shall be exempt from any licensing requirements where the cranes are used in connection with the installation or maintenance of street lighting or public utility overhead power distribution systems.

1.1.3 Derricks having a maximum rated capacity not exceeding one ton.

2.0 Definitions.-

2.1 ACCESSORY.-A secondary part of assembly of parts which contributes to the overall function and usefulness of a machine.

2.2 APPOINTED.-Assigned specific responsibilities by the employer or by the employers representative.

2.3 ANGLE INDICATOR (boom).-An accessory which measures the angle of the boom to the horizontal.

2.4 AUXILIARY HOIST.-(See Whipline).

2.5 AXIS OF ROTATION.-The vertical axis around which the crane superstructure rotates.

2.6 AXLE.-The shaft or spindle with which or about which a wheel rotates. On truck and wheel mounted cranes it refers to an automotive type of axle assembly including housing, gearing, differential, bearings and mounting appurtenances.

2.7 AXLE (bogie).-Two or more automotive type axles mounted in tandem in a frame so as to divide the load

between the axles and permit vertical oscillation of the wheels.

2.8 BASE (mounting).The base or carrier on which the rotating superstructure is mounted such as a truck, crawler or platform.

2.9 BOOM. A timber or metal section or strut. The heel (lower end) is affixed to a base, carriage or support, and the upper end supports a cable and sheaves where the load is lifted by means of wire rope and hook.

2.10 BOOM ANGLE. The angle between the longitudinal centerline of the boom and the horizontal. The boom longitudinal centerline is a straight line between the boom foot pin (heel pin) centerline, and boom point sheave pin centerline.

2.11 BOOM HARNESS. The block and sheave arrangement on the boom point to which the topping lift cable is reeved for lowering and raising the boom.

2.12 BOOM HOIST.-A hoist drum and rope reeving system used to raise and lower the boom.

2.13 BOOM POINT.-The outward end of the top section of the boom.

2.14 BOOM STOP.-A device used to limit the angle of the boom at the highest position.

2.15 BRAKE.-A device used for retarding or stopping motion by friction or power means.

2.16 CAB.-A housing which covers the rotating superstructure machinery and/or operators station.

2.16.1 CABLEWAY.-A power operated system for moving loads in a generally horizontal direction in which the loads are conveyed on an overhead cable, track or carriage.

2.16.2 CLIMBER CRANE.-A crane erected upon and supported by a building or other structure which may be raised or lowered to different floors or levels of the building or structure.

2.17 CLUTCH.-A friction, electromagnetic, hydraulic, pneumatic or positive mechanical device for engagement of power.

2.18 COUNTERWEIGHT.-Weight used to supplement the weight of the machine in providing stability for lifting working loads.

2.19 CRANE.-A power operated machine for lifting or lowering a load and moving it horizontally which utilizes wire rope and in which the hoisting mechanism is an integral part of the machine.

2.20 CRAWLER CRANE.-A crane consisting of a rotating superstructure with power plant, operating machinery and boom, mounted on a base, equipped with crawler treads for travel.

2.21 DERRICK.-An apparatus consisting of a mast or equivalent members held at the top by guys or braces, with or without a boom, for use with a hoisting mechanism and operating rope, for lifting or lowering a load and moving it horizontally.

2.21.1 A-FRAME DERRICK.-A derrick in which the boom is hinged from a cross member between the

Reference Standard 19

bottom ends of two upright members spread apart at the lower ends and joined at the top; the boom point secured to this junction of the side members, and the side members are braced or guyed from the junction point.

2.21.2 BASKET DERRICK.-A derrick without a boom, similar to a gin pole with its base supported by ropes attached to corner posts or other parts of the structure. The base is at a lower elevation than its supports. The location of the base of a basket derrick can be changed by varying the length of the rope supports. The top of the pole is secured with multiple reeved guys to position the top of the pole to the desired location by varying the length of the upper guy lines. The load is raised and lowered by ropes through a sheave or block secured to the top of the pole.

2.21.3 BREAST DERRICK.-A derrick without a boom. The mast consists of two side members spread farther apart at the base than at the top and tied together at top and bottom by rigid members. The mast is prevented from tipping forward by guys connected to its top. The load is raised and lowered by ropes through a sheave or block secured to the top crosspiece.

2.21.4 CHICAGO BOOM DERRICK.-A boom which is attached to a structure, an outside upright member of the structure serving as the mast, and the boom being stepped in a fixed socket clamped to the upright. The derrick is complete with load, boom and boom point swing line falls.

2.21.5 GIN POLE 2 DERRICK.-A derrick without a boom. Its guys are so arranged from its top to permit leaning the mast in any direction. The load is raised and lowered by ropes reeved through sheaves or blocks at the top of the mast.

2.21.6 GUY DERRICK.-A fixed derrick consisting of a mast capable of being rotated, supported in a vertical position by guys, and a boom whose bottom end is hinged or pivoted to move in a vertical plane with a reeved rope between the head of the mast and the boom point for raising and lowering the boom, and a reeved rope from the boom point for raising and lowering the load.

2.21.7 SHEARLEG DERRICK.-A derrick without a boom. The mast, wide at the bottom and narrow at the top, is hinged at the bottom and has its top secured by a multiple reeved guy to permit handling loads at various radii by means of load tackle suspended from the mast top.

2.21.8 STIFFLEG DERRICK.-A derrick similar to a guy derrick except that the mast is supported or held in place by two or more stiff members, called stifflegs, which are capable of resisting either tensile or compressive forces. Sills are generally provided to connect the lower ends of the stifflegs to the foot of the mast.

2.22 DRUM.-The cylindrical members around which ropes are wound for raising and lowering the load or boom.

2.23 DYNAMIC (loading).-Loads introduced into the machine or its components by forces in motion.

2.23.1 ENGINEER.-The word engineer as used in these regulations shall mean a licensed professional engineer except that the certifications for matters relating to crane design may be made by an engineer licensed by any state or foreign jurisdiction or upon proof, to the satisfaction of the commissioner, of his professional competence.

2.23.2 FOLDING BOOM.-A boom constructed of hinged sections which is articulated in a folding manner and may be folded for storage or transit.

2.24 GANTRY (A-Frame).-A structural frame, extending above the superstructure of a mobile crane, to which the boom supports ropes are reeved.

2.25 GUDGEON PIN.-A pin connecting the mast cap to the mast, allowing rotation of the mast.

2.26 GUY.-A rope used to steady or secure the mast or other members in the desired position.

2.26.1. HOISTING MACHINE.-A power operated machine used for lifting or lowering a load, utilizing a drum and wire rope, excluding elevators. This shall include but not be limited to a crane, derrick, and cableway.

2.26.2 HYDRAULIC BOOM.-A boom which is operated by means of a hydraulic system.

2.27 JIB.-An extension attached to the boom point to provide added boom length for lifting specified loads. This jib may be in line with the boom or offset to various angles.

2.27.1 LAY.-That distance measured along a cable in which one strand makes a complete revolution around the cable axis.

2.28 LOAD (working).-The external load, in pounds, applied to the crane or derrick, including the weight of auxiliary load attaching equipment such as load blocks, shackles, and slings.

2.29 LOAD BLOCK (upper).-The assembly of hook or shackle, swivel, sheaves, pins, and frame suspended from the boom point.

2.30 LOAD BLOCK (lower).-The assembly of hook or shackle, swivel, sheaves, pins and frame suspended by the hoisting ropes.

2.31 LOAD HOIST.-A hoist drum and rope reeving system used for hoisting and lowering loads.

****2.31.1 LOAD INDICATOR.**- A device that measures the weight of the load.

2.32 LOAD RATINGS.-Maximum loads that may be lifted by a crane or derrick at various angles and positions as approved by the department.

2.33 MAST.-The upright member of a derrick.

2.33.1 MOBILE CRANE.-A crawler crane; a truck crane; or a wheel mounted crane.

2.34 OUTRIGGERS.-Extendable or fixed metal arms, attached to the mounting base, which rests on supports at the outer ends.

Reference Standard 19

****2.34.1 QUALIFIED PERSON.** - A person who by possession of a recognized degree, certificate or professional standing or who by knowledge, training and experience has successfully demonstrated his/her ability to solve or resolve problems related to the subject matter, the work, or the project.

****2.34.2 RATED CAPACITY INDICATOR.** - A device that automatically monitors radius, load weight, and load rating and warns the crane operator of an overload condition.

****2.34.3 RATED CAPACITY (LOAD) LIMITER.** - A device that automatically monitors radius, load weight, and load rating and prevents movements of the crane which would result in an overload condition.

2.35 REEVING.-A rope system in which the rope travels around drums and sheaves.

2.36 ROPE.-Refers to wire rope unless otherwise specified.

2.37 SIDE LOADING.-A load applied at an angle to the vertical plane of the boom.

2.38 SILL.-A member connecting the foot block and stiffleg or a member connecting the lower ends of a double member mast.

2.39 STANDING (GUY) ROPE.-A supporting rope which maintains a constant distance between the points of attachment to the two components connected by the rope.

2.40 STRUCTURAL COMPETENCE.-The ability of the machine and its component to withstand the stresses imposed by applied loads.

2.41 SUPERSTRUCTURE. The rotating upper frame structure of the machine and the operating machinery mounted thereon.

2.42 SWING. Rotation of the superstructure for movement of loads in a horizontal direction about the axis of rotation.

2.43 SWING MECHANISM. The machinery involved in providing rotation of the superstructure.

2.44 TACKLE. An assembly of ropes and sheaves arranged for hoisting and pulling.

2.44.1 TELESCOPIC BOOM. A boom constructed of sections of diminishing cross sections in which the sections fit within each other. The boom may be extended in a manner similar to a telescope.

2.44.2 TOWER CRANE.-A crane in which a boom, swinging jib or other structural member is mounted upon a vertical mast or tower.

2.45 TRANSIT.-The moving or transporting of a crane from one job site to another.

2.46 TRAVEL.-The function of the machine moving from one location to another, on a job site.

2.47 TRAVEL MECHANISM.-The machinery involved in providing travel power.

2.48 TRUCK CRANE.-A crane consisting of a rotating superstructure with power plant, operating machinery and boom, mounted on an automotive truck equipped

with a power plant for travel.

2.48.1 TRUCK MOUNTED TOWER CRANE.-A tower crane which is mounted on a truck or similar carrier for travel or transit.

****2.48.2 TWO-BLOCKING.** - A condition in which the lower load block or hook assembly comes into contact with the upper load block or boom point sheave assembly.

2.49 WHEEL BASE.-Distance between centers of front and rear axles. For a multiple axle assembly the axle center wheel base measurement is taken as the midpoint of the assembly.

2.50 WHEEL MOUNTED CRANE (wagon crane).-A crane consisting of a rotating superstructure with power plant, operating machinery and boom, mounted on a base or platform equipped with axles and rubber tired wheels for travel. The base is usually propelled by the engine in the superstructure, but it may be equipped with a separate engine controlled from the superstructure. Its function is to hoist and swing loads at various radii.

2.51 WHIPLINE (auxiliary hoist).-A separate hoist rope system of lighter load capacity and higher speed than provided by the main hoist.

2.52 WINCH HEAD.-A power driven spool for handling of loads by means of friction between fiber or wire rope and spool.

****3.0 Filing Applications for Approval and Operation of Cranes and Derricks. -**

****3.1 Certificate of approval.** -The application for a certificate of approval required by Subchapter 19, Article 10 of the New York City Building Code shall be filed by an engineer and shall include the following information:

1. Affidavit of compliance from the manufacturer as detailed in section 3.2 below,
2. Operator's manual showing all configurations for which the engineer is seeking approval, general equipment specifications and manufacturer's recommended maintenance procedures,
3. An advertising brochure or drawing showing the general configuration and specifications for which the engineer is seeking approval,
4. Load rating chart with chart number and page numbers for identification,
5. Certification from the engineer that he/she has reviewed the manufacturer's design calculations and testing or has prepared sufficient calculations, as prescribed in section 3.2 below and found that the design of the derrick or crane conforms to the New York City Building Code, and
6. Any supporting data, drawings, or calculations upon request.

Reference Standard 19

Exception: Third party certification: In lieu of the engineer's certification of the design calculations, the engineer may submit a third-party certification by a competent individual or organization, other than the manufacturer, acceptable to the commissioner stating that the tests specified in section 4.2 below were monitored and certified.

****3.2 Affidavit of compliance.** - The affidavit of compliance from the manufacturer shall include the following:

1. List of all components; maximum boom length, maximum jib(s) length, maximum length of all other attachments,
2. List of all counterweight combinations,
3. List of standards used in the design of the boom and/or mast,
4. List of standards used in the design of the jib and/or extensions,
5. List of standards used in the design of the boom support system,
6. List of standards used in the design of the counterweight support system and attachments,
7. List of standards used in the design of the rope,
8. List of standards used in design of overturning stability,
9. List of standards used in the prototype testing, and
10. List of material(s) and material specifications used in the components listed in Numbered Items 3-7 above.

Exception to required items: Numbered items 2, 6, 8, and 9 above are not required for derricks.

****4.0 Design, construction, and testing of mobile cranes.** -

****4.1 Design and construction of mobile cranes.**-

****4.1.1 Design and construction of mobile cranes manufactured and submitted prior to October 1, 2006.** Mobile cranes, and their components, manufactured and submitted prior to October 1, 2006 shall, in their entirety, be designed and constructed in accordance with ANSI B30.5 – 1968.

****4.1.2 Design and construction of mobile cranes manufactured and submitted on or after October 1, 2006.** Mobile cranes, and their components, manufactured and submitted on or after October 1, 2006, shall, in their entirety, be designed and constructed in accordance with one of the following standards:

1. ANSI B30.5 – 2004 Chapter 5-1 except Section 5-1.9.9
2. CEN EN 13000 (2004) except Section 4.2.6

****4.1.3 Design and construction of mobile cranes manufactured prior to October 1, 2006 but**

submitted after October 1, 2006. Mobile cranes, and their components, submitted on or after October 1, 2006, but manufactured before October 1, 2006, shall, in their entirety, be designed and constructed in accordance with one of the following standards:

1. ANSI B30.5 – 2004 Chapter 5-1 except Section 5-1.9.9
2. ANSI B30.5 – 2000 Chapter 5-1 except Section 5-1.9.9
3. ANSI B30.5 – 1994 Chapter 5-1 except Section 5-1.9.9
4. ANSI B30.5 – 1989 Chapter 5-1 except Section 5-1.9.9
5. ANSI B30.5 – 1982 Chapter 5-1 except Section 5-1.9.9
6. CEN EN 13000 (2004) except Section 4.2.6
7. Such other standard as the Commissioner deems appropriate.

****4.2 Prototype testing of mobile cranes.** -

****4.2.1 Prototype testing of mobile cranes submitted prior to October 1, 2006.** A prototype of each mobile crane, and their components, submitted before October 1, 2006 shall be tested for strength and stability in accordance with ANSI B30.5-1968. Lattice boom cranes shall also be tested in accordance with SAE J987 and all mobile cranes with lattice or hydraulic booms shall also be tested in accordance with SAE J765.

****4.2.2 Prototype testing of mobile cranes submitted on or after October 1, 2006.** A prototype of each mobile crane, and their components, submitted on or after October 1, 2006 shall meet the prototype testing requirements in Test Option A or Test Option B as outlined below:

1. Test Option A:

- (a) The following applies to equipment with cantilevered booms (such as hydraulic boom cranes): All tests listed in SAE J1063 - 1993, Table 1, shall be performed to load all critical structural elements to their respective limits. All the strength margins listed in SAE J1063 - 1993, Table 2 shall be met.
- (b) The following applies to equipment with pendant supported lattice booms: All the tests listed in SAE J987 - 2003, Table 1, shall be performed to load all critical structural elements to their respective limits. All the strength margins listed in SAE J987 – 2003, Table 2 shall be met.
- (c) Load rating charts shall be established by tests performed in accordance with

Reference Standard 19

SAE J765-1990, Crane Load Stability Test.

2. Test Option B:
 - (a) The following applies to equipment with cantilevered booms (such as hydraulic boom cranes): The analysis methodology, such as computer modeling, must demonstrate that all load cases listed in SAE J1063 - 1993 meet the strength margins listed in SAE J1063-1993 Table 2.
 - (b) The following applies to equipment with pendant supported lattice booms: The analysis methodology, such as computer modeling, must demonstrate that all load cases listed in SAE J987 - 2003 meet the strength margins listed in SAE J987- 2003 Table 2.
 - (c) The analysis methodology, such as computer modeling, must demonstrate that the load chart ratings meet the requirements of SAE J765 - 1990.
 - (d) Analysis verification. The physical testing requirements under SAE J1063 - 1993 and SAE J987 - 2003 must be met unless the reliability of the analysis methodology, such as computer modeling, has been demonstrated by a documented history of verification through strain gauge measuring or strain gauge measuring in combination with other physical testing. The physical testing requirements of SAE J765 - 1990 must be met unless the reliability of the analysis methodology, such as computer modeling, has been demonstrated by physical testing.

***Section 5, 6 and 7 are deleted in their entirety*

8.0 Certificate of On-Site Inspection.-

8.1 Use of cranes and derricks at job sites. -

8.1.1 In order to operate a crane or derrick at a job site, a certificate of on-site inspection is required as stipulated in C26-1909.4(d). The owner of the premises, building or structure, or his designated representative, shall file an application in quadruplicate at the department office in the borough where the premises is located. Such application shall be accompanied by plans showing proposed locations of the crane or derrick, pertinent features of the site such as assumed soil bearing values, ground elevations and slopes, vaults or other subsurface structures, supporting platforms or structures, and the swing of the crane or derrick. Also, a document shall be submitted, signed by a licensed engineer or registered

architect which shall include the following information where the crane or derrick is to be supported by soil:

- (a) That he has inspected the soil at the proposed location or locations of the crane or derrick;
- (b) His estimate of the soil bearing value;
- (c) That he has explored the existence of any sheeting or retaining walls supporting soil adjoining any excavation which may be affected and certifies as to its adequacy;
- (d) If the crane or derrick is to be on the street, that he has explored the existence of vaults or other subsurface structures which could impair the bearing value of the street or sidewalk;
- (e) That the load imposed upon the soil by the crane or derrick including supporting platform, does not exceed such bearing value under any condition of loading.

8.1.2 Where a crane not exceeding 160 feet in height, including jibs and any other extensions to the boom is to be used for a period not exceeding 24 hours, or a crane not exceeding 50 feet in height, including jibs and any other extensions to the boom with a maximum rated capacity of 20 tons, is to be positioned on the roadway or sidewalk, a certificate of on-site inspection shall be required. However, the requirements relating to plans and a document of a licensed professional engineer or registered architect enumerated in 8.1.1 of this reference standard shall not apply nor shall the three regular working day provisions of section C26-1909.4(d) be applicable under the following conditions:

(1) That a prototype approval has been obtained showing the means required to distribute the weight of the crane and the maximum working loads.

(2) A statement from the owner of the structure, building or premises or his authorized agent that he visited the site and that there are no excavations or retaining walls and that no vaults or subsurface construction exists at the site.

8.1.3 A certificate of on-site inspection shall not be required under the following conditions:

* 8.1.3.1 For a crane not exceeding 160 feet in height including jibs and any other extensions to the boom, which is to be used for a period not exceeding 48 hours and operating entirely within the property lines and in such locations which are at least a boom length, including jibs and any extensions thereof, distant from all lot lines.

**Local Law 50-1973*

8.1.3.2 For service cranes and clamshells operated entirely within the property lines and within such locations which do not involve the moving of any loads over the roadway or sidewalk. This exemption shall apply only to cranes with a boom length, including jibs and any extension thereof, not exceeding 110 feet.

* 8.1.3.3 For the use of cranes as provided for in 8.1.3.1 and 8.1.3.2, notice of the operation of the crane at the job site shall be given to the division of cranes and derricks, department of buildings, by telephone and confirmed in writing. It shall be the responsibility of an

Reference Standard 19

appointed person to provide firm and uniform footing and, when necessary, provide substantial timbers, cribbing or other structural members sufficient to distribute the load so as not to exceed the safe bearing capacity of the underlying material.

**Local Law 50-1973*

8.2 Cranes or Derricks Supported by a Building or Structure.-

8.2.1 Where the crane or derrick is supported by a building or a structure, the statement by the licensed engineer or registered architect referred to in 8.1.1 shall include the means of supporting and bracing the equipment. The swing of the crane or derrick shall be shown on the plans to insure clearance during operation. Computations shall be submitted with the application showing all reactions imposed on the structure by the crane or derrick, including those due to impact and wind. Such computations shall verify that the stability of the building or structure will not be impaired when the crane or derrick is in operation and that no structural members will be overstressed due to forces induced by the crane or derrick.

8.2.2 Concrete Structures.-If the structure is a concrete structure, test reports of the compression strength of the concrete shall be submitted to insure that the concrete supports of the crane or derrick have developed sufficient strength to support the crane or derrick before it is installed.

The means for establishing concrete strength before imposing crane or derrick loads upon the structure shall be indicated on the application.

8.2.3 All anchorages for cranes and derricks shall be approved by an appointed person.

8.3 Use of Pile Drivers and Clamshells.-

8.3.1 A certificate of on-site inspection shall not be required for pile drivers or clamshells operating entirely within the lot lines under the following conditions:

8.3.1.1 Where pile driving equipment is designed or supported on a platform so that the soil bearing pressure does not exceed 500 pounds per square foot, a certificate of on-site inspection shall not be required.

8.3.1.2 Where clamshells are operating on construction sites and are at least the depth of excavation height from the edge of the excavation and where the soil bearing pressure does not exceed 500 lbs. per square foot, a certificate of on-site inspection shall not be required.

8.3.1.3 Where the pressure on the soil is in excess of 500 pounds per square foot but does not exceed 2,500* pounds per square foot, a pile driver or clamshell may be operated without a certificate of on-site inspection under the following conditions:

(1) That borings have been filed with the department in the construction application under which the work is being performed, and

(2) An amendment is filed to such application by an engineer or architect certifying that on the basis of the

borings, the soil is adequate to support the load to be imposed thereon by the subject equipment.

8.4 The Requirements of 8.1.1, 8.2 and Sections C26-1909.4(d) Shall also Apply to Cableways.-

† 8.5 Notwithstanding the provisions of 8.0 through 8.4 where a crane is operated on the sidewalk or roadway, a permit from the department of highways shall be obtained and the pressure on such surface shall not exceed 3500 pounds per square foot. The pressure shall be distributed on the roadway by means of timber platforms extending not less than twelve (12) inches beyond the base of the outriggers on all sides and sufficiently thick to uniformly distribute the pressure as required above of all the loads including the weight of the crane. The timber mats shall have a minimum thickness of two (2) inches. All cranes equipped with steel tracks shall be supported by timber platforms not less than six inches thick and covering the entire base of the crane.

† Local Law 73-1969; 479 -77 BCR

9.0 Unsafe Hoisting Machines.-

9.1 When it is found that equipment is dangerous or unsafe a notice or order to stop work may be issued by the commissioner, or his authorized representative. Such notice or order may be given to the owner or lessee of the equipment involved, or to the agent of any of them, or to the person or persons executing the work or operating the equipment in writing. If the operation of the hoisting machine is not discontinued, the inspector shall report same to his superior and an engineer shall be sent to reinspect. Upon confirmation of the unsafe condition by the engineer, the hoisting machine shall be red tagged. All persons shall be prohibited from using the said equipment until the danger is removed or the unsafe condition is rectified. An unsafe notice shall not be removed from the equipment, except by an authorized inspector or representative of the department of buildings.

10.0 Annual Renewal of Certificate of Operation.-

Application for renewal of a certificate of operation, as stipulated in C26-1909.4 (c), shall be accompanied by inspection and maintenance records in accordance with 15.1 and 18.1. Upon approval of the application, a new certificate of operation shall be issued after a satisfactory inspection by a department inspector.

***Section 11 and 12 are deleted in their entirety*

13.0 Load Ratings Where Structural Competence Governs Lifting Performance.-

****13.1** Load ratings for climber, tower cranes and derricks are governed by structural competence. Therefore, the limitation on crane loading must be such that no structural member is overstressed, and load rating charts shall be subject to this limitation.

Reference Standard 19

13.2 Load Rating Chart.-

****Section 13.2.1 and 13.2.2 are deleted in their entirety**

****Section 13.2.3 is renumbered as follows**

****13.2.1** Tower and climber cranes.- A substantial, durable and clearly legible rating chart shall be provided with each tower and climber crane and securely affixed in the cab. The chart shall include load ratings approved by the department for specific lengths of components, counterweights, swing, and radii.

****Section 14 is deleted in its entirety**

15.0 Inspection Required by Owner for Cranes and Derricks.-

15.1 Certification and inspections required.-The owner of a crane or derrick when applying for a certificate of approval in accordance with 3.0 shall certify that all applicable regulations regarding inspection and maintenance will be complied with. All inspections required by the owner shall be performed only by appointed personnel. The inspections shall be performed to provide information requested in a department supplied chart and all deficiencies shall be corrected. No record of information not required by such chart shall be required to be maintained in writing.

15.2 Inspection classification.-Inspection procedure for cranes and derricks in regular service is divided into two general classifications based upon the intervals at which inspection should be performed. The intervals in turn are dependent upon the nature of the critical components of the crane or derrick and the degrees of their exposure to wear, deterioration or malfunction. The two general classifications are herein designated as "frequent" and "periodic" with respective intervals between inspections as defined below:

15.2.1 Frequent inspection.-Daily to monthly intervals.

15.2.2 Periodic inspection.-1 to 12 month intervals or as specifically recommended by the manufacturer.

***15.3 Frequent inspection.**-Items such as the following shall be inspected for defects at intervals as defined in 15.2.1 or as specifically indicated, including observation during operation for any defects which might appear between regular inspections. Any defects revealed by inspection shall be corrected. Where such defects constitute a safety hazard, the crane or derrick shall not be operated until such defects are corrected.

***Local Law 50-1973**

15.3.1 All control mechanisms for maladjustment interfering with proper operation.-Daily.

15.3.2 All control mechanisms for excessive wear of components and contamination by lubricants or other foreign matter.

15.3.3 All safety devices for malfunction.

15.3.4 Deterioration or leakage in air or hydraulic systems.-Daily

***15.3.5** Crane or derrick hooks with deformations or cracks.-Refer to 17.3.3(c).

***Local Law 50-1973**

15.3.6 Rope reeving for non-compliance with crane or derrick manufacturer's recommendations.

15.3.7 Electrical apparatus for malfunctioning, signs of excessive deterioration, dirt, moisture accumulation, weatherproofing and grounding.

15.3.8 Tension in derrick guys.-Daily.

15.3.9 Plumb of derrick mast.

15.3.10 Hoist brakes, clutches and operating levers.-Check daily for proper functioning before beginning operations.

***15.4 Periodic inspections of cranes and derricks.**-Complete inspections of the crane or derrick shall be performed at intervals as generally defined in 15.2.2, depending upon its activity, severity of service, and environment, or as required by 15.5.1 or 15.5.2. These inspections shall include the requirements of 15.0, and in addition, items specifically indicated below. Any defects revealed by inspection shall be corrected. Where such defects constitute a safety hazard the crane or derrick shall not be operated until such defects are corrected.

***Local Law 50-1973**

15.4.1 Deformed, cracked or corroded members in the crane or derrick structure and boom.

15.4.2 Loose bolts or rivets.

15.4.3 Cracked or worn sheaves and drums.

15.4.4 Worn, cracked or distorted parts such as pins, bearings, shafts, gears, rollers and locking devices.

15.4.5 Excessive wear on brake and clutch system parts, linings, pawls and ratchets.

15.4.6 Load, boom angle and other indicators over their full range, for any significant inaccuracies.

15.4.7 Gasoline, diesel, electric or other power plants for improper performance or non-compliance with safety requirements.

15.4.8 Excessive wear of chain drive sprockets and excessive chain stretch.

15.4.9 Crane or derrick hooks.-Magnetic particle or other suitable crack detecting inspection should be performed at least once each year by an inspection agency retained by the owner and approved by the department. Certified inspection reports are to be made available to the department upon request.

15.4.10 Travel steering, braking and locking devices, for malfunction.

15.4.11 Excessively worn or damaged tires.

15.4.12 Derrick gudgeon pin for cracks, wear and distortion each time the derrick is to be erected.

15.4.13 Foundation or supports shall be inspected for continued ability to sustain the imposed loads.

15.5 Cranes or derricks not in regular use.-

****15.5.1** A crane or derrick which has been idle for the period of one month or more, but less than six months, shall be given an inspection by the owner conforming with requirements of 15.3 and 18.1.1 before an application for a certificate of on-site inspection in

Reference Standard 19

accordance with 27-1057(d) is submitted to the department.

****15.5.2** A crane which has been idle for the period of over six months, shall be given a complete inspection by the owner conforming with requirements of 15.3, 15.4 and 18.1.2 before an application for a certificate of on-site inspection in accordance with 27-1057(d) is submitted to the department.

16.0 Testing Required for Cranes and Derricks, Manufactured After April 1, 1970, by Manufacturer or Owner.-

16.1 Operational test.-

16.1.1 In addition to prototype tests and quality control measures, each new production crane and derrick shall be tested by the manufacturer to the extent necessary to insure compliance with the operational requirements of this section, including functions such as the following:

- (a) Load hoisting and lowering mechanisms.
- (b) Boom hoisting and lowering mechanisms.
- (c) Swinging mechanism.
- (d) Traveling mechanism.
- (e) Safety devices.

16.1.2 Where the complete production crane or derrick is not supplied by one manufacturer such tests shall be conducted at final assembly.

6.1.3 Operational test and production test results certified by the manufacturer or a licensed professional engineer shall be made available to the department with each application for a certificate of approval for a crane or derrick, in accordance with 3.0.

16.1.4 For all cranes and derricks, where electrically powered, the trip setting of hoist limit switches shall be determined by tests with an empty hook traveling in increasing speeds to the maximum speed. The activating mechanism of the limit switch shall be located so that it will trip the switch under all conditions in sufficient time to prevent contact of the hook or load block with any part of the derrick or crane.

17.0 Maintenance of Cranes and Derricks.-

17.1 Preventive maintenance.-

17.1.1 A preventive maintenance program based on the crane or derrick manufacturer's recommendations shall be established. Dated and detailed records shall be readily available to the department.

17.1.2 It is recommended that replacement parts be obtained from the original equipment manufacturer.

17.2 Maintenance procedure.-

17.2.1 Before adjustments and repairs are started on a crane or derrick, the following precautions shall be taken as applicable:

- (a) Crane or derrick placed or arranged where it will cause the least interference with other equipment or operations in the area.
- (b) All controls at the "off" positions.

(c) Starting means rendered inoperative.

(d) Warning or "out of order" signs placed on the crane or derrick and hoist.

(e) Power plant stopped or disconnected at take-off.

(f) Boom lowered to the ground if possible or otherwise secured against dropping.

(g) Lower load block lowered to the ground or otherwise secured against dropping.

17.2.2 After adjustment and repairs have been made, the crane or derrick shall not be operated until all guards have been reinstalled, safety devices reactivated and maintenance equipment removed.

17.3 Adjustments and Repairs.-

*17.3.1 Any unsafe conditions disclosed by the inspection requirements of 15.0 shall be corrected before operation of the crane or derrick is resumed. Adjustments and repairs shall be done only by competent personnel.

**Local Law 50-1973*

17.3.2 Adjustments shall be maintained to assure correct functioning of components. The following are examples:

- (a) All functional operating mechanisms.
- (b) Safety devices.
- (c) Control systems.
- (d) Power plants.
- (e) Tie downs or anchorages.
- (f) Signal system.
- (g) Guys.

††17.33 Repairs or replacements shall be provided promptly as needed for safe operation. The following are examples:

†† *As enacted but "17.3.3" probably intended*

(a) All critical parts of functional operating mechanisms which are cracked, broken, corroded, bent or excessively worn.

(b) All critical parts of the crane or derrick structure which are cracked, bent, broken or excessively corroded.

* (c) Crane or derrick hooks showing defects described in 15.3.5 shall be discarded. Repairs by welding or reshaping are not acceptable unless written approval of the department is obtained.

**Local Law 50-1973*

(d) Pitted or burned electrical contacts should be corrected only by replacement and in sets. Controller parts should be lubricated as recommended by the manufacturer.

17.3.4 All replacement parts or repairs shall have at least the original safety factor and be in accordance with the specifications of the manufacturer. Approval of the department shall be required for the replacement or repair of main structural members as enumerated in 1 and 2 of 3.1.1 for which no fee will be required.

17.4 Lubrication of Cranes and Derricks.-

17.4.1 All moving parts of the crane or derrick and hoist for which lubrication is specified, including rope and chain, shall be regularly lubricated. Lubricating systems

Reference Standard 19

shall be checked for proper delivery of lubricant. Particular care should be taken to follow manufacturer's recommendations as to point and frequency of lubrication, maintenance of lubricant levels and types of lubricants to be used. Lubrication shall be performed under the supervision of the crane operator, oiler or maintenance engineer.

*17.4.2 Machinery shall be stationary while lubricants are being applied and protection provided as called for in 17.2.1(b) through 17.2.1(e) inclusive, unless such machinery is equipped for automatic lubrication.

**Local Law 50 -1973*

18.0 Rope Inspection, Replacement and Maintenance by Owner for Cranes and Derricks.-

****18.1 Rope Inspection. -**

****18.1.1 Frequent Inspection. -**

****18.1.1.1** All ropes in continuous service shall be visually inspected once every working day. A visual inspection shall consist of observation of all rope that can reasonably be expected to be in use during the day's operation. This visual inspection shall be directed towards discovering gross damage that may be an immediate hazard, including the following:

- (a) Distortion of the rope such as kinking, crushing, unstranding, birdcaging, main strand displacement, or core protrusion. Loss of rope diameter in a short rope length or unevenness of outer strands should provide evidence that the rope or ropes must be replaced.
- (b) General corrosion
- (c) Broken or cut strands
- (d) Number, distribution and type of visible broken wires (See Section 18.2.2 for further guidance)
- (e) Core failure in rotation-resistant ropes. When such damage is discovered, the rope shall be either removed from service or given an inspection as detailed in Section 18.1.2

****18.1.1.2** Care shall be taken when inspecting sections of rapid deterioration such as flange points, crossover points, and repetitive pickup points.

****18.1.1.3** Care shall be taken when inspecting the following types of rope:

- (a) Rotation-resistant rope.
- (b) Boom hoist rope.

****18.1.2 Periodic Inspection. -**

****18.1.2.1** There shall be periodic inspections performed at least annually. The inspection frequency shall be determined by a qualified person and shall be based on such factors as expected rope life as determined by experience on the particular installation or similar installations, severity of the environment, percentage of capacity lifts, frequency rates of operation, and exposure to shock loads. Inspections need not be at equal calendar intervals and should be more frequent as the rope approaches the end of its useful life.

****18.1.2.2** In the event a periodic inspection is not feasible within a 12-month period due to existing set-up and configuration of the equipment or due to site conditions, such periodic inspection shall be performed as soon as it becomes feasible but no longer than an additional 6 months for running ropes and, for standing ropes, at the time of disassembly. Written notification and approval of the commissioner must be obtained prior to extending the use of the rope beyond the 12-month inspection period.

****18.1.2.3** Periodic inspections shall be performed by a qualified person. This inspection shall cover the entire length of rope. Only the surface wires of the rope shall be inspected. Any deterioration resulting in an appreciable loss of original strength shall be noted and determination made as to whether further use of the rope would constitute a hazard. The periodic inspection shall include examination of the following:

- (a) points listed in Section 18.1.1.1
- (b) reduction of rope diameter below nominal diameter due to loss of core support, internal or external corrosion, or wear of outside wires.
- (c) severely corroded or broken wires at end connections
- (d) severely corroded, cracked bent, worn or improperly applied end connections

****18.1.2.4** Care shall be taken when inspecting sections of rapid deterioration, such as the following:

- (a) sections in contact with saddles, equalizer sheaves, or other sheaves where rope travel is limited
- (b) sections of the rope at or near terminal ends where corroded or broken wires may protrude.

****18.1.2.5** All rope that has been idle for a period of six months or more shall be given a periodic inspection before it is placed into service.

****18.2 Rope Replacement. -**

****18.2.1** When a rope reaches any one of the specified removal criteria, it may be allowed to operate to the end of the work shift, based on the judgement of a qualified person. The rope shall be replaced after that work shift, at the end of the day, or at the latest time prior to the equipment being used by the next work shift.

****18.2.2** Removal criteria for rope replacement shall meet manufacturer's specification or as follows:

- (a) Broken Wires
 - (1) in running ropes, six randomly distributed broken wires in one lay or three broken wires in one strand in one lay.

Reference Standard 19

- (2) In rotation-resistant ropes, two randomly distributed broken wires in six diameters or four randomly distributed broken wires in 30 rope diameters.
- (3) One outer wire broken at the point of contact with the core rope that has worked its way out of the rope structure and protrudes or loops out from the rope structure. Additional inspection of this section is required.
- (4) Kinking, crushing, birdcaging, or any other damage resulting in distortion of the rope structure.
- (5) Evidence of heat damage from any cause
- (6) Reductions from nominal diameter of more than the following:
 - (a) 1/64 in. for diameters up to and including 5/16 in.
 - (b) 1/32 in. for diameters up to and including 1/2 in.
 - (c) 3/64 in. for diameters up to and including 3/4 in.
 - (d) 1/16 in. for diameters up to and including 1 1/8 in.
 - (e) 3/32 in. for diameters up to and including 1 1/2 in.
- (7) In standing ropes, more than two broken wires in one lay in sections beyond end connections or more than one broken wire at an end connection.

****18.2.3** Replacement rope shall have strength rating at least as great as the original rope furnished or recommended by the crane manufacturer. Any deviation from the original size, grade, or construction shall be specified by the rope manufacturer, the crane manufacturer, or a qualified person.

****18.2.4** Discarded rope shall not be used for slings.

18.3 Rope Maintenance.-

18.3.1 Rope shall be stored to prevent damage or deterioration.

18.3.2 Unreeling or uncoiling of rope shall be done as recommended by the rope manufacturer and with extreme care to avoid kinking or inducing a twist.

18.3.3 Before cutting a rope, seizings shall be placed on each side of the place where the rope is to be cut to prevent unlaying of the strands. On preformed rope, one seizing on each side of the cut is required. On non-

preformed ropes of 7/8 inch diameter or smaller, two seizings on each side of the cut are required, and for non-preformed rope of one inch diameter or larger, three seizings on each side of the cut are required.

18.3.4 During installation care shall be observed to avoid dragging of the rope in dirt or around objects which will scrape, nick, crush, or induce sharp bends in it.

18.3.5 Rope should be maintained in a well lubricated condition. It is important that lubricant applied as part of a maintenance program shall be compatible with the original lubricant and to this end the rope manufacturer should be consulted. Those sections of rope which are located over sheaves or otherwise hidden during inspection and maintenance procedures require special attention when lubricating rope. The object of rope lubrication is to reduce internal friction and to prevent corrosion. Periodic field lubrication is particularly important for non-rotating rope.

****19.0 Safety Devices Required.** - All cranes and derricks shall be equipped with safety devices as provided herein, except equipment used exclusively for pile driving, clamshell and dragline used for excavation. The commissioner shall approve these safety devices.

****19.1 Indicators or Limiters.** - All mobile cranes with a maximum rated capacity of 3 tons or more shall be equipped with a load indicator, rated capacity indicator, or a rated capacity (load) limiter.

****19.1.1** Cranes with a total boom length including jibs and any other extensions not exceeding 150 feet shall be exempt.

****19.1.2** Cranes manufactured before December 30, 1993 shall be exempt. The margin of stability for determination of load ratings of these cranes shall be established at 75 percent of the load, which will produce a condition of tipping or balance with the boom in the least stable direction relative to the mounting where overturning stability governs the lifting performance.

****19.1.3** Cranes shall have a radius or boom angle indicator provided in conjunction with a load indicator.

****19.2 Anti-Two Blocking Features.** - All mobile cranes with a maximum rated capacity exceeding one ton manufactured after February 28, 1992, shall be equipped with anti-two-blocking features as follows:

- (a) Telescopic Boom Cranes shall have an anti-two-block device for all points of two-blocking that automatically prevents damage from contact between the load block, overhaul ball, or similar component, and the boom and/or jib tip.

Reference Standard 19

- (b) Lattice Boom Cranes shall have an anti-two-block device for all points of two-blocking that either automatically prevents damage from contact between the load block, overhaul ball, or similar component, and the boom and/or jib tip or warns the operator in time for the operator to prevent two-blocking.

****19.3 Additional Safety Devices Required.** - All mobile cranes with a maximum rated capacity exceeding one ton shall be equipped with the following additional safety devices:

- (a) A deadman control on the control levers in the cab or crane operator's station, where the crane is electrically powered.
- (b) An effective audible warning and operating signal on the outside of the cab.
- (c) Boom stops and boom hoist safety shutoffs. However, boom stops shall not be required for telescoping booms.
- (d) An indicator for leveling the crane.
- (e) Hoist drum rotation indicator if the drum is not visible from the operator's station.

****19.4 Malfunctioning Safety Devices.** - The load indicator, rated capacity indicator, rated capacity (load) limiter, hoist drum rotation indicator, and the anti-two blocking devices shall also be known as operational aids, which provide information to facilitate the operation of a crane or that take control of particular functions without action of the operator when a limiting condition is sensed. When any of these operational aids are inoperative or malfunctioning, the following alternative measures shall be implemented to allow continued use of the crane:

- (a) Load indicator, Rated capacity indicator or Rated Capacity (Load) Limiter: The weight of the load shall be determined from a reliable source (such as the manufacturer's equipment specification), by a reliable calculation method (such as calculating a steel beam from measured dimensions and a known per foot weight) or by other equally reliable means before the load is hoisted. To ensure that the weight of the load does not exceed the crane ratings at the maximum radius at which the load is to be handled, the radius shall be determined through the use of a boom angle indicator, radius indicator or by measurement.
- (b) Hoist drum rotation indicator: Mirrors and/or remote video cameras and displays shall be provided so that the operator can see the drum.

- (c) Anti-two-block device: The cable shall be clearly marked (so that it can easily be seen by the operator) at a point that will give the operator sufficient time to stop the hoist to prevent two-blocking or an additional signal person shall be utilized to monitor the position of the load block or overhaul ball.

Recalibration or repair of the safety device shall be accomplished as soon as is reasonably possible, as determined by a qualified person.

****19.5 Tower Cranes and Climber Cranes.** - All tower cranes and climber cranes excluding truck-mounted tower cranes shall have the following:

- (a) Warning light activated at 100% allowable overturning moment,
- (b) Acoustic signal sounding at 105% allowable overturning moment,
- (c) Automatic stop if 110% allowable overturning moment is reached,
- (d) Automatic stop if load exceeds maximum rated load in high gear,
- (e) Automatic stop if load exceeds maximum rated load in intermediate gear,
- (f) Automatic stop if load exceeds maximum rated load in low gear,
- (g) Predeceleration before top position of the hook,
- (h) Limit switch for top position of the hook,
- (i) Predeceleration before low position of the hook,
- (j) Limit switch for the trolley traveling out,
- (k) Limit switch for the trolley traveling in,
- (l) Acceleration limit on the hoisting movement,
- (m) Acceleration limit on the swing movement,
- (n) Acceleration limit on the trolley movement, and
- (o) Deadman control on both control levers in box.

****19.6 Derricks.**-Safety devices for derricks shall be approved by the commissioner and shall be installed within six months after said devices are accepted. However, where electrically powered, a deadman control on control levers shall be installed prior to applying for a certificate pursuant to section 27-1057 of the Administrative Code.

***Section 20 is deleted in its entirety*

21.0 Characteristics and Special Requirements for Derricks.-

21.1 Load ratings.-

* 21.1.1 Rated load marking.-

**Local Law 50-1973*

- (a) For derricks, a substantial, durable and clearly legible load rating chart shall be provided for each

Reference Standard 19

particular installation. The rating chart shall be securely affixed where it is visible to personnel responsible for the operation of, the equipment. The chart shall include but not be limited to the following data:

1-manufacturer's load ratings as approved by the department at corresponding ranges of boom angle or operating radii.

2-specific lengths of components on which the load ratings are based.

3-required parts for hoist reeving.

4-size and construction of all ropes shall be shown either on the rating chart or in the operating manual.

(b) For all other derricks, the manufacturer shall provide sufficient information from which capacity charts can be prepared and approved by the department for the particular installation. The capacity charts shall be located either at the derrick or the job site office.

21.2 Construction.-

21.2.1 General.-Derricks shall be constructed to adequately meet all stresses imposed on all members and components.

21.2.2 Guy derricks.-

(a) The minimum number of guys is six. Preferably, the guys should be equally spaced around the mast.

(b) The manufacturer shall furnish complete information recommending:

1-the number of guys.

2-the spacing around the mast;

3-the maximum vertical slope and initial tension or sag of all guys;

4-the size and construction of rope to be used in each.

(c) The mast base shall permit free rotation of the mast with allowance for slight tilting of the mast caused by guy slack.

(d) The mast cap shall:

1-permit free rotation of the mast;

2-adequately withstand tilting and cramping action imposed by the guy loads;

3-be secured to the mast to prevent disengagement during erection;

4-be provided with means for attachment of guy ropes.

21.2.3 Stiff leg derrick. -

(a) The mast shall be supported in the vertical position by two stiff legs one end of each being connected to the top of the mast and the other end securely anchored. The stiff legs shall be capable of withstanding the loads imposed by the boom at any point within its range of swing.

(b) The mast base shall:

1 - permit free rotation of mast;

2 - permit slight inclination of the mast without binding;

3 - provide means to prevent the mast from lifting out of its socket when the mast is in tension.

(c) The stiff leg connecting member at the top of the

mast shall:

1 - permit free rotation of the mast;

2 - adequately withstand the loads imposed by the action of the stiff legs;

3 - be so secured as to oppose lift off forces at all times.

21.3 Ropes and reeving accessories.-

21.3.1 Guy ropes.-

(a) Guy ropes shall be of suitable size, grade and construction to withstand the maximum load imposed.

(b) The nominal breaking strength of each rope shall be no less than three times the load applied to the rope.

(c) Tie downs or kicker devices which may be easily loosened shall have locknuts or other suitable provision to prevent loosening.

21.3.2 Boom hoist ropes.-

(a) Boom hoist ropes shall be of suitable size, grade and construction to withstand the maximum load imposed.

(b) The live rope reeving system in a boom suspension shall withstand the maximum load imposed and be of sufficient length to permit lowering the boom point to horizontal position with at least three full wraps of rope remaining on the hoist drum.

(c) The nominal breaking strength of the most heavily loaded rope in a system shall be no less than three and a half times the loads applied to that rope.

21.3.3 Main hoist ropes.-

(a) Main hoist ropes shall be of a suitable size and construction to withstand the maximum load imposed.

(b) Ropes in the main hoisting system shall be of sufficient length for the entire range of movement specified for the application with at least three full wraps of rope on the hoist drum at all times.

(c) The nominal breaking strength of the most heavily loaded rope in a system shall be no less than three and a half times the load applied to that rope.

21.3.4 Reeving accessories.-

(a) Socketing shall be done in the manner specified by the manufacturer of the assembly.

(b) Rope end shall be anchored securely to the drum.

(c) Eyes shall be made in an approved manner and rope thimbles should be used in the eye.

(d) U-bolt clips shall have the U-bolt on the dead or short end, and the saddle on the live or long end of the rope. Spacing and number of all types of clips shall be in accordance with the clip manufacturer's recommendation and submitted to the department. Clips shall be drop-forged steel in all sizes manufactured commercially. When a newly installed rope has been in operation for an hour, all nuts on the clip bolts shall be retightened, and they should be checked for tightness at frequent intervals thereafter.

(e) Swaged, compressed, or wedge-socket fittings shall be applied as recommended by the rope, derrick, or fitting manufacturer.

(f) Where a half wedge socket is used it shall be of a

Reference Standard 19

positive locking type.

(g) If a load is supported by more than one rope, the tension in the parts shall be equalized.

21.3.5 Sheaves.-

(a) Sheave grooves shall be smooth and free from surface defects which could cause rope damage. The cross sectional radius at the bottom of the groove should be such as to form a close fitting saddle for the size rope used and the sides of the groove should be tapered outwardly to facilitate entrance of the rope into the groove. Flange corners should be rounded and the rims should run true about the axis of rotation.

(b) Sheaves carrying ropes which can be momentarily unloaded shall be provided with close fitting guards or other suitable devices to guide the rope back into the groove when the load is applied again.

(c) The sheaves in the lower load block shall be equipped with close-fitting guards that will prevent ropes from becoming fouled when the block is lying on the ground with ropes loose.

(d) Means should be provided, if necessary, to prevent chafing of the ropes.

(e) All running sheaves shall be equipped with means for lubrication. Permanently lubricated, sealed and/or shielded bearings shall be acceptable.

(f) Boom and hoisting sheaves shall have pitch diameters not less than eighteen times the nominal diameter of the rope used.

(g) Boom point sheaves should be provided with suitable guides to limit the offlead angle of the rope when entering the grooves from either side.

21.4 Anchoring and guying.-

21.4.1 Guy derricks.-

(a) The mast base shall be securely anchored. Maximum horizontal and downward vertical thrusts encountered when handling rated loads with the particular guy slope and spacing stipulated for the application are among the design factors for which provision must be made.

(b) The guys shall be secured to the ground or other firm anchorage. Maximum horizontal and vertical pulls encountered while handling rated loads with the particular guy slope and spacing stipulated for the application are among the factors for which provision must be made.

21.4.2 Stiff leg derricks.-

(a) The mast base shall be securely anchored. Maximum horizontal and upward and downward vertical thrusts encountered while handling rated loads stipulated for the application with the particular stiff-leg spacing and slope are among the factors for which provision must be made.

(b) The stiff legs shall be securely anchored. Maximum horizontal and vertical upward and downward thrusts encountered while handling rated loads with the particular stiff-leg arrangement stipulated for the application are among the factors for which provision must be made.

21.5 Hoist.-

21.5.1 The hoist shall be suitable for the derrick work intended and shall be securely anchored to prevent displacement from the imposed loads.

*21.6 Cranes manufactured prior to April 1, 1970 shall be modified to conform to the provisions of 20.1.1(d) and (f), 20.1.2(h) and (i), 20.2.3, 20.3.1(b) and (c), 20.3.2(a)(2), 20.4.5, 20.5.1(b) and derricks manufactured prior to April 1, 1970 shall be modified to conform to the provisions of 21.3.5(f), unless it can be shown to the satisfaction of the commissioner that the crane can not feasibly or economically be altered to comply.

**Local Law 50-1973*

22.0 Operation Cranes and Derricks. -

22.1 Operators.-

22.1.1 Cranes and derricks shall be operated only by the following persons:

(a) Persons licensed as operators by the department of buildings in accordance with section B26-5.0.

(b) Learners in the presence of and under the direct supervision of a licensed operator.

22.1.2 No person other than those listed under paragraph 22.1.1 above and persons such as oilers and supervisors, whose duties require them to do so, shall enter the cab of a crane and then only in the performance of his duties and with knowledge and consent of the operator.

22.2 Operating practices.-

22.2.1 The operator shall not engage in any practice which will divert his attention while actually engaged in operating the crane or derrick hoist.

22.2.2 The operator shall respond to signals only from the appointed signal men.

22.2.3 The operator shall be responsible for the operation of the crane or derrick hoist.

* 22.2.4 For mobile cranes, the warning signal shall be sounded each time before on-site traveling and intermittently during such travel, particularly when approaching workmen.

** Local Law 50-1973*

22.2.5 Before leaving his crane or derrick unattended, the operator shall:

(a) Land any attached load, bucket, lifting magnet, or other device.

(b) Disengage clutches.

(c) Set travel, swing, boom brakes and other locking devices.

(d) Put controls in the "off" position.

(e) Stop the engine.

(f) Secure mobile cranes against accidental travel.

(g) Lock and secure the equipment against unauthorized operation.

22.2.6 On leaving a mobile crane overnight, ground chocks shall be set and crane booms shall be lowered to ground level or otherwise fastened securely against displacement by wind loads or other external forces.

22.2.7 If there is a warning sign on the switch or engine starting controls, the operator shall not close the switch or start engine until the warning sign has been removed

Reference Standard 19

by the person placing it there.

22.2.8 Before closing the switch, or starting the engine, the operator shall see to it that all controls are in the "off" position and all personnel are in the clear.

22.2.9 If power fails during operation, the operator shall:

- (a) Set all brakes and locking devices.
- (b) Move all clutch or other power controls to the "off" position.
- (c) Communicate with the appointed individual in charge of operations.
- (d) If practical, the suspended load should be landed under brake control.

22.2.10 The operator shall familiarize himself with the equipment and its proper care. If adjustments or repairs are necessary, or any defects are known he shall report the same promptly to his employer or other person responsible for the equipment and shall also notify the next operator of the defects upon changing shifts.

22.2.11 All controls shall be tested by the operator at the start of a new shift. If any controls do not operate properly, they shall be adjusted or repaired before operations are begun.

22.2.12 Booms of mobile cranes which are being assembled or disassembled on the ground with or without support of the boom harness (equalizing sheaves, bridle and boom pendants) should be securely supported by proper blocking to prevent dropping of the boom sections.

23.0 Handling the Load.-No crane or derrick shall be loaded beyond the rated load.

23.1 Size of load.- On all operations involving cranes or derricks which are not equipped with those safety devices which make use of load measuring systems, there shall be a competent appointed individual assigned on a full-time basis to be responsible for determining the magnitude of loads to be lifted or lowered. The operator shall not make a lift unless he has first determined the weight of the load or is informed of such weight by the appointed person responsible for the operation.

23.2 Attaching the load.-

23.2.1 The hoist rope shall not be wrapped around the load.

23.2.2 The load shall be attached to the hook by means of slings or other approved devices.

23.3 Moving the load.-

23.3.1 The appointed individual directing the lift shall see that:

- (a) In the case of a mobile crane, the crane is level and where necessary, chocked properly.
- (b) The load is well secured and properly balanced in the sling or lifting device before it is lifted more than a few inches.

23.3.2 Before starting to hoist, he shall take care that:

- (a) Hoist ropes are not kinked.
- (b) Multiple part lines are not twisted around each other.
- (c) The hook is brought over the load in such a manner as to prevent swinging.
- (d) If there is a slack rope condition, the rope is properly seated on the drum and in the sheaves.

23.3.3 During hoisting, care should be taken that:

(a) There is no sudden acceleration or deceleration of the moving load.

(b) The load does not contact any obstructions.

23.3.4 Side loading of booms shall be limited to freely suspended loads. Cranes shall not be used for dragging loads sideways. Derricks shall not be used for side loading.

****23.3.5** The operator shall not lift, lower, swing or travel while any person is on the load or hook unless notification is filed with the Department pursuant to Section 23.6 of this title. The operator shall not carry loads over people or over any occupied building unless the top two floors are vacated or overhead protection with a design live load of 300 psf is provided.

23.3.6 On truck cranes, loads shall be lifted over the front area only as recommended by the manufacturer and submitted to the department of buildings.

23.3.7 The operator shall test the brakes each time a load approaching the rated load is handled by raising it a few inches and applying the brakes.

23.3.8 For mobile cranes, outriggers shall be used when the load to be handled at that particular radius exceeds the rated load without outriggers as given by the manufacturer for that crane and approved by the department of buildings.

23.3.9 Neither the load nor the boom shall be lowered below the point where less than three full wraps of rope remain on their respective drums.

23.3.10 When two or more cranes are used to lift one load, one appointed person shall be responsible for the operation. He shall analyze the operation and instruct all personnel involved in the proper positioning, rigging of the load, and the movements to be made.

23.3.11 In transit, the following additional precautions for mobile cranes shall be exercised:

(a) The boom shall be carried in line with the direction of motion.

(b) The superstructure shall be secured against rotation. When negotiating turns or when the boom is supported on a dolly, the superstructure may be rotated by a licensed crane operator only.

(c) The empty hook shall be lashed or otherwise restrained so that it cannot swing freely.

23.3.12 Before traveling a crane with a load, proposed travel should be shown on a plan of operation and approved by the department. Such data shall be filed with an application for on-site inspection.

23.3.13 A crane shall not be traveled with the boom so high that it may bounce back over the cab.

23.3.14 When rotating the crane or derrick, sudden stops shall not be made. Rotational speed shall be such that the load does not swing out beyond the radii at which it can be controlled. A tag or restraint line shall be used when rotation of the load is hazardous.

23.3.15 When a crane is to be operated at a fixed radius, the boom hoist pawl or other positive locking device

Reference Standard 19

shall be engaged.

23.3.16 Use of winch heads:

- (a) Ropes shall not be handled on a winch head without knowledge of the operator.
- (b) While a winch is being used, the operator shall be within convenient reach of the power unit control lever.

23.4 Holding the load.-

23.4.1 The operator shall not leave his position at the controls while the load is suspended.

23.4.2 People shall not be permitted to stand or pass under a load.

23.4.3 If the load must remain suspended for any considerable length of time, the operator shall hold the drum from rotating in the lowering direction by activating the positive controllable means at the operator's station.

23.4.4 In all cases, when booms are raised or lowered from the horizontal, load blocks including hooks and weight balls shall be left on the ground or deposited to the ground before raising or lowering booms.

23.5 Securing derrick booms.-

23.5.1 Dogs, pawls, or other positive braking mechanism on the hoist shall be engaged. When not in use, the derrick boom shall:

- (a) Be laid down;
- (b) Be secured to a stationary member, as nearly under the head as possible, by attachment of a sling to the load block; or
- (c) Hoisted to a vertical position and secured to the mast.

****23.6 Hoisting Personnel.** - Written notification shall be submitted to the commissioner at least three (3) business days prior to the date the hoisting equipment may be used to move personnel. In addition to the requirements of this section, the applicant shall also comply with all applicable OSHA requirements.

****23.6.1** The applicant shall be an engineer or a licensed master rigger. However, where the boom length, including jibs and any other extensions, is greater than 250 ft, the applicant shall be an engineer.

****23.6.2** The notification shall include the following:

- (a) A description of work,
- (b) The start date and duration of the work,
- (c) Manufacturer's information on the personnel platform used to perform the work,
- (d) The number of people who will be on the platform,
- (e) The actual pick load and the maximum radius of the pick,
- (f) The allowable pick load for maximum radius from load chart approved by the commissioner,
- (g) Description of how the person/people on the platform and the hoisting machine operator will communicate,

- (h) Designation of Site Safety coordinator,
- (i) Equipment user's company name, and address, and
- (j) The name and title of principal from the equipment user company.

****23.6.2.1** Where the applicant is an engineer, the request shall also include a copy of the Certificate of On-Site Inspection.

****23.6.2.2** Where the applicant is a master rigger, the request shall also include:

- (a) The make, model number and Certificate of Operation of the Hoisting Machine
- (b) A sketch or description of the foundation for the hoisting machine

****23.6.3** Exception: If the boom length, including jibs and any other extensions, is less than 100 ft. and the lift is supervised by a master rigger, written notification is not required.

24.0 Signals.-

24.1 A signalman shall be provided when the point of operation is not in full and direct view of the operator unless an approved mechanical signaling or control device is provided for safe direction of the operator.

24.2 Only persons who are dependable and fully qualified by experience with the operation shall be used as signalmen.

24.3 A signalman or other appropriate controls shall be provided when operations or equipment on or adjacent to a highway create a traffic hazard.

24.4 Signalmen shall wear high visibility gloves.

24.5 A uniform hand signal system shall be used on all operations of a similar nature. The system in use by the U.S. Corps of Engineers †† (EM 385-11) may be used as the model.

†† *As enacted but (EM 385-1-1) probably intended.*

24.6 Manual hand signals may be used when the distance between the operator and the signalman is not more than 60 feet, but manual hand signals shall not be used when atmospheric conditions prevent clear visibility to the operator.

24.7 Mechanical signal systems shall be protected against unauthorized use, breakage, weather or obstruction which will interfere with safe operation. In the event of any malfunction, all motion shall be stopped immediately.

25.0 Miscellaneous.-

25.1 Ballast or counterweight. - Cranes shall not be operated without the full amount of any ballast or counterweight in place as specified by the maker, and approved by the department.

25.2 Wind speed limitations. - No crane or derrick operator shall start an operation when the wind speed exceeds 30 m.p.h., or when the wind is predicted to reach 30 m.p.h. before the operation can be completed. The U.S. weather bureau data from the nearest reporting

Reference Standard 19

station may be used for the determination of wind speed.

25.3 Operating near electric power lines. -

25.3.1 No crane or derrick shall be operated in such a location that any part of the machine or of its load shall at any time come within 15 feet of an energized power line.

25.3.2 Before the commencement of operations near electrical lines, the appointed person responsible for the operation shall notify the owners of the lines or their authorized representatives providing them with all pertinent information and requesting their cooperation.

25.3.3 Any overhead wire shall be considered to be an energized line unless and until the person owning such line or the electrical utility authorities certify that it is not an energized line.

25.4 Electrical equipment.-

25.4.1 General.-

(a) Wiring and equipment shall comply with the electrical code of the City of New York.

(b) The voltage used on control circuits shall not exceed 750 volts.

25.4.2 Equipment.-

(a) Electric equipment shall be so located or enclosed that live parts will not be exposed to accidental contact.

(b) All motor, controller and switch frames shall be grounded.

(c) Electric equipment shall be thoroughly protected from dirt, grease and oil, and where exposed to the weather, shall be thoroughly protected therefrom.

(d) Guards for live parts shall be substantial and so located that they cannot be deformed so as to make contact with the live parts.

(e) Name plates shall not be removed.

25.4.3 Controllers.-

(a) Each cage operated crane and derrick shall be provided with a device which will disconnect all motors from the line on failure of power and will not permit any motor to be restarted until the controller handle is brought to the "off" position, or a reset switch or button is operated.

(b) Lever operated controllers shall be provided with a notch or latch which in the "off" position prevents the handle from being inadvertently moved to the "on" position.

(c) The controller operating handle shall be located within convenient reach of the operator.

(d) As far as practicable, the movement of each controller handle shall be in the same general directions as the resultant movements of the load.

(e) For floor operated cranes and derricks, the controller or controllers, if rope operated, shall automatically return to the "off" position when released by the operator.

25.4.4 Grounding.-Each crane, which may be operated in the vicinity of a live power line, shall be effectively grounded as hereinafter provided. The crane shall be provided with a permanent clamp or other means for convenient and effective attachment of a grounding conductor. The cable connecting the clamp to the ground

shall be equivalent to a No. 2 AWG or larger single conductor, superflexible, rope stranded copper, composed of not less than 1,600 individual wires, with 600 volt covering for mechanical protection and with terminal parts that insure a good connection with hand type screw clamps. An effective ground shall be one having a resistance of 25 ohms or less, which shall be measured, or a connection to a continuous underground metallic water piping system.

25.5 Demolition.-

25.5.1 Crane or derrick operation when used for mechanical demolition shall comply with section C26-1905.4(d) of the building code and, in addition, a crane or derrick operating with a demolition ball shall meet the following requirements:

(a) The weight of the demolition ball shall not exceed fifty percent of the rated capacity of the boom length at its maximum radius.

(b) The swing of the boom shall not exceed thirty degrees from the centerline, front to back of the crane mounting.

(c) The load line and attachment of the demolition ball to the load line shall be checked at least twice daily.

(d) Truck cranes without outriggers extended shall not be used to swing a demolition ball.

26.0 Storage.-

26.1 Necessary clothing and personal belongings shall be stored in or about the crane or derrick in such a manner as to not interfere with access or operation.

26.2 Tools, oil cans, waste, extra fuses, and other necessary articles shall be stored in a tool box and shall not be permitted to lie loose in or about the cab or cage.

27.0 Refueling.-

27.1 Refueling shall comply with section C26-1909.1(c).

27.2 Machines shall not be refueled with the engine running.

28.0 Fire Extinguishers.-

28.1 A carbon dioxide, dry chemical or equivalent fire extinguisher shall be kept in the cab or in the vicinity of the crane or derrick.

28.2 Operating and maintenance personnel shall be familiar with the use and care of the fire extinguishers provided.

29.0 Filing for Prototype Equipment.-Where the equipment is a duplicate of equipment previously filed with design information and approved by the department, the previous approval shall be accepted for the design. Evidence shall be submitted that the welding and other manufacturing processes affecting the structural integrity of the crane were performed in accordance with applicable specifications and that required controls were maintained and tests performed.

30.0 Waiver of Modification of Rules and Regulations.-

Reference Standard 19

The commissioner may, at his discretion, modify or waive any of the foregoing requirements where practical difficulties in complying with particular sections exist and the public safety is not endangered thereby.

****DOB 10/1/06**

*****Local Law 73-1969**

***** RS 19-3 CABLEWAYS**

1.0 Scope.-This standard applies to the use of cableways for the construction, alteration and repair of buildings.

2.0 Definition.-

2.1 A power operated system for moving loads in a generally horizontal direction in which the loads are conveyed on an overhead cable, track or carriage.

3.0 An on-site inspection shall be required for cableways used for the erection, alteration and repair of buildings. The provisions of article 9.0 of RS 19-2 shall apply and for this purpose the word, "cableway" shall be substituted for "crane" or "derrick" where those words appear in article 9.0.

*****Local Law 73-1969**

*** REFERENCE STANDARD RS 19-4 SAFETY NETS**

ANSI A10.11-1989-American national standard for personnel and debris nets used during construction, repair and demolition operations, as modified.

Modifications-The provisions of ANSI A10.11-1989 shall be subject to the following modifications:

(1) Section 3.1 of such national standard shall be deemed to read as follows:

3.1 Safety nets shall be provided in accordance with sections 27-1021 and 27-1022 of the administrative code.

(2) Such national standard shall be deemed to include two new sections 10.8 and 10.9 to read as follows:

10.8 On each elevation of a building, the open sided permanent floor edges shall be guarded by a vertical net lining or its equivalent up to a height of not less than sixty inches.

10.9 When nets are installed vertically, they shall be supported so as to be capable of withstanding a lateral force of two hundred pounds.

***Local Law 61-1987; 234-90 BCR**

Rules and Regulations

APPENDIX A

SELECTED RULES OF THE DEPARTMENT OF BUILDINGS TITLE 1 OF THE RULES OF THE CITY OF NEW YORK

Cite as:

For chapters: Title No. RCNY Chapter No.—*example:* 1 RCNY Chapter 4

For sections: Title No. RCNY §No.—*example:* 1 RCNY §4-02

Chapter

Section Rules

Ch. 1 Material and Equipment Application Procedures

§1-01 Material and Equipment Application Procedures

Ch. 2 Boiler Inspections

§2-01 Low Pressure Boiler Inspections by Qualified Boiler Inspectors and Welding Repairs by Certified Welders

§2-02 Reduction of Penalties for Late Filing of Annual Low Pressure Boiler Inspection Reports

Ch. 3 Vacant and Unguarded Buildings

§3-01 Sealing and Protection of Vacant and Unguarded Buildings

§3-02 Obtaining Access to Keys of Sealed Premises

§3-03 Hearings to Determine Whether Sealing Orders Were Properly Issued

§3-04 Obtaining Access to Keys of Premises Sealed Pursuant to §26-127.2 of the Administrative Code

Ch. 4 Certificates of Occupancy, Live Loads and Occupancy Loads

§4-01 Posting Requirements

Ch. 5 Concrete

§5-01 Conveyance by Pumping Methods

§5-02 Licensing of Concrete Testing Laboratories

§5-03 Approval of Prequalified Concrete Mixes

§5-04 Approval of Concrete Production Facilities

Ch. 6 Cranes

§6-01 Erection and Dismantling of Climber/Tower Cranes

Ch. 7 Installation and Maintenance of Vent Damper Devices in Existing Boilers and Furnaces

§7-01 Retrofitting of Vent Damper Devices [REPEALED]

Ch. 8 Demolition

§8-01 Commencement of Demolition

Ch. 9 Rigging Operations

§9-01 Supervisory Responsibilities of a Licensed Master or Special Rigger

§9-02 Supervisory Responsibilities of a Licensed Master or Special Sign Hanger

§9-03 Minimum Requirements for Individuals Working on Suspension Scaffolds Exhibits

§9-04 Revocation, Suspension or Refusal to Renew License of Special or Master Rigger or Special or Master Sign Hanger

Ch. 10 Drums for Derrick Load and Boom Hoists

§10-01 Requirements

Ch. 11 Elevators, Escalators, Personnel Hoists and Moving Walks

§11-01 Rules for the Certification and Qualification of Private Elevator Inspection Agencies and for the Performance of Inspections and Filing of Inspection Reports for Elevators and Escalators by such Agencies

§11-02 Elevator and Escalator Violations Constituting a Condition Dangerous to Human Life and Safety

§11-03 Cease Use Orders for Elevators, Personnel Hoists, Escalators and Moving Walks

§11-04 Separability

§11-05 Certification of Completion of Work after Issuance of Temporary Use Permit for an, Escalator and Other Device, Except Amusement Devices, Listed in §§27-185(b) or 27-982 of the Administrative Code

Rules and Regulations

§11-06 Elevators, Escalators or Other Devices, Except Amusement Devices, Listed in §27-185(b) or §27-982 of the Administrative Code, Renewal of Temporary Use Permits and Fees

Ch.12 Emergency Power Systems

§12-01 Emergency Power System Requirements

Ch. 13 Adjudications

Subchapter A [REPEALED]

Subchapter B

Rules Governing Adjudication Procedures

§13-11 Purpose

§13-12 Definitions

§13-13 Pre-Hearing Procedure

§13-14 Commencement of Disciplinary Proceedings

§13-15 Disclosure

§13-16 Adjournments

§13-17 Subpoenas

§13-18 Conduct of Hearings

§13-19 Board Initiated Investigatory Hearings

§13-20 Evidentiary Standard of Proof

§13-21 Decisions, Determinations and Orders

Ch. 14 Fees [REPEALED]

Ch. 15 Fire Protection

§15-01 Communication and Alarm Systems (“Mini-Class ‘E’ Systems”) for Certain Buildings under 100 Feet in Height

§15-02 Interior Fire Alarm and Signal System for Place of Assembly Used as a Cabaret and for Stages, Dressing Rooms and Property Rooms

§15-03 Extension of Time to Complete Installations for Buildings in Occupancy Group E Over 100 Feet in Height **[REPEALED]**

§15-04 Exemption of Certain Existing J-1 Residential Hotels from Certain Fire Safety Special Filing Requirements

§15-05 Filing and Approval of a Fire Safety Plan for Buildings Containing Transient Occupants Such as Hotels and Motels

§15-06 Design of Composite Construction with Metal Decks or Lightweight Concrete

§15-07 Fire-Retarding of Entrance Halls, Stair Halls and Public Halls in Old Law Tenements and Converted Dwellings

§15-08 Fire-Retarding of Cellar Ceilings in Old Law Tenements and Converted Dwellings

§15-09 Fire-Retarding of Cooking Spaces in all Multiple Dwellings

§15-10 Fire-Escapes, Fire Stairs and Fire Towers

Ch. 16 Inspection of Existing Structures During Construction Operations

§16-01 Controlled Inspection of the Stability and Integrity of Existing Structures During Construction Operations

Ch. 17 Testing Laboratories and Testing Services

§17-01 Acceptance of Testing Laboratories and Testing Services

Ch. 18 Resistance to Progressive Collapse Under Extreme Local Loads

§18-01 Considerations and Evaluation

Ch. 19 Master Plumbers and Licensed Fire Suppression Piping Contractors

§19-01 Examination, License and Conduct of the Business of Master Plumbers and Master Fire Suppression Piping Contractors

§19-02 Continuing Education Requirements for Master Plumbers and Licensed Master Fire Suppression Piping Contractors

§19-03 Exemptions from Inspection and Testing Requirements.

§19-04 Master Plumber and Master Fire Suppression Piping Contractor License Board – Qualification Recommendations

Ch. 20 Piping Systems

§20-01 Witnessing Tests of Gas Piping Systems

§20-02 High Pressure Steam Piping Systems

§20-03 Waiver of Examination and Grandfathering for Master Fire Suppression Piping Contractors **[REPEALED]**

§20-03 Standards for Non-Mercury Gauges

Ch. 21 Plans

§21-01 Limited Supervisory Check and/or Professional Certification Program for Applications and Plans

Rules and Regulations

§21-02 Exclusion from Limited Supervisory Check and/or Professional Certification Programs

Ch. 22 Pressure Tanks

§22-01 Installation and Maintenance of Pressure Tanks Operating at a Pressure in Excess of 15 PSI and Their Proximity to Gas Supply or Service Lines

Ch. 23 Noncommercial Greenhouses

§23-01 Noncommercial Greenhouses Accessory to Residential Uses as a Permitted Obstruction in Required Rear Yards or Rear Yard Equivalents

Ch. 24 Refuse Chutes and Refuse Rooms

§24-01 Construction and Maintenance of Refuse Chutes and Refuse Rooms

Ch. 25 Climber and Tower Crane Riggers

§25-01 Licensing Persons as Climber or Tower Crane Rigger

Ch. 26 Safety of Public and Property During Construction Operations

§26-01 Filing of Site Safety Programs and Designation of Site Safety Managers

§26-02 Safety Netting During Construction Operations

§26-03 Storage of Materials During Construction Operations

§26-04 Use of Reshores During Construction Operations

Appendix A The Department of Buildings Manual for Site Safety Programs

Ch. 27 Signs

§27-01 Stair and Elevator Signs in Buildings Which Have at Least One Elevator

§27-02 Caution Sign Tapes Required on Elevators Being Serviced

§27-03 Signs on any Sidewalk Shed, Fence, Railing, Footbridge, Catch Platform, Builder's Sidewalk Shanty, and Over-the-Sidewalk Chute Erected at Demolition or Construction Sites

§27-04 311 Advisory Signs Required on Construction Sites

Ch. 28 Smoke Detecting Devices and Systems and Carbon Monoxide Detecting Devices and Systems

§28-01 Required Smoke Detecting Devices and Systems

§28-02 Required Carbon Monoxide Detecting Devices and Systems

Ch. 29 Sprinkler Systems

§29-01 Installation of Automatic Sprinklers in Halls and Rooms in Class "A" Multiple Dwellings Used For Single-Room Occupancy Under the Provisions of Subdivision 7-A of §4 and §248 of the Multiple Dwelling Law

§29-02 Installation of Automatic Wet-Pipe Sprinklers in Certain Class A and Class B Multiple Dwellings, Including Hotels, Under the Provisions of §67, Multiple Dwelling Law

§29-03 Installation of Automatic Wet-Pipe Sprinkler Systems and Alarm Systems in Certain Class B Multiple Dwellings (Lodging Houses)

§29-04 Installation of Automatic Wet-Pipe Sprinkler Systems and Alarm Systems in Certain Class B Multiple Dwellings (Lodging Houses)

§29-05 Installation of Automatic Wet-Pipe Sprinklers in Fireproof Multiple Dwellings Converted to Business Use

§29-06 Installation of Automatic Sprinklers in the Public Halls of Multiple Dwellings Under the Provisions of §187 (Converted Dwellings) and §218, Subdivisions 5 (Old-Law Tenements), of the Multiple Dwelling Law, and of the Sprinklers in Cooking Spaces in all Types of Multiple Dwellings Under the Provisions of §33 of the Multiple Dwelling Law

§29-07 Installation of Wet-Pipe Sprinklers

§29-08 Installation of Sprinklers in Rooms of Class B Non-Fireproof Converted Dwellings and in Rooms Used for Class B Occupancy in Non-Fireproof Class A Converted Dwellings Under the Provisions of §194 of the Multiple Dwelling Law

§29-09 Installation of Chlorinated Poly Vinyl Chloride (CPVC) Sprinkler Pipe and Fittings

Ch. 30 Storage of Certain Waste Materials

§30-01 Enclosures of Premises Used for Automobile Wrecking, Storage of Scrap Metal, Junk, Scrap Paper or Rags, Storage of Lumber, and Building Material or Contractors' Yards

§30-02 Open Lots Used for Storage or Sale of Motor Vehicles

Ch. 31 Suspension, Revocation or Limitation of Registration

Rules and Regulations

§31-01 Suspension, Revocation or Limitation of Registration of Persons Who Present, Submit, Furnish or Seek Approval of Applications for Approval of Plans or Remove Any Documents from the Possession of the Department of Buildings

Ch. 32 Walls

§32-01 The Design and Installation of Curtain Wall and Panel Wall (Non-Loadbearing Exterior Wall) Systems

§32-02 Conditions of a Building's Exterior Walls and Appurtenances That Constitute Conditions Dangerous to Human Life and Safety

§32-03 Periodic Inspection of Exterior Walls and Appurtenances of Buildings

§32-04 Masonry Parapet Walls

§32-05 Impact Resistant Stair and Elevator Enclosures

Ch. 33 Exemptions from Civil Penalties

§33-01 Exemption from Civil Penalties Imposed Pursuant to Administrative Code §26-212.1 (Work Performed Without a Permit)

Ch. 34 Electrical Code Rules

Subchapter A

Phase-in of Electrical Code Technical Standards

§34-01 Phase-in of New Standards for Electrical Work

§34-02 Review of Applications for Electrical Permits and Certificates of Electrical Inspection during the Phase-in Period

§34-03 Temporary Certification to Perform Low Voltage Electrical Work

§34-04 Definitions

§34-05 Electrical Advisory Board

§34-06 Electrical Code Revision and Interpretation Committee

§34-07 Electrical Code Advisory Committee

Ch. 35 Electrical Inspection

§35-01 Designation of Private Agencies to Perform Electrical Inspections in the City of New York

§35-02 Payment of Fees for Certificates of Electrical Inspection

Ch. 36 Electrical Contractors

§36-01 Evaluation of Educational Experience of Applicants for Electrical Contractor Licenses

§36-02 Impact of Periods of Unemployment upon Applications for Electrician's Licenses

Ch. 37 Reference Standards

§37-01 Rules of Procedure for Amending, Revising or Promulgating Reference Standards

Ch. 38 Ventilation

§38-01 Ventilation of Garage Spaces Below Grade

Ch. 39 Cooling Towers and Evaporative Condensers

§39-01 Cooling Towers and Evaporative Condensers

Ch. 40 Installation and Maintenance of Gas-Fueled Water and Space Heaters in all Portions of Dwellings Used or Occupied for Living Purposes

Subchapter A Scope

B Departmental Procedure

C Where Heaters May be Used

D Installation of Gas-Fueled Heaters

Subchapter A Scope

§40-01 Installation and Maintenance of Gas-Fueled Water and Space Heaters in all Portions of Dwellings Used or Occupied for Living Purposes

Subchapter B Departmental Procedure

§40-11 Applications and Plans

§40-12 Examination and Approval of Applications

§40-13 Commencement of Work

§40-14 Inspection of Gas-Fueled Space and Water Heaters

§40-15 Issuing Approvals

Rules and Regulations

Subchapter C Where Heaters May be Used

§40-21 Substitution for Central Heating or Hot Water Supply

Subchapter D Installation of Gas-Fueled Heaters

- §40-31 Required Approvals of Appliances
- §40-32 Prohibited Types of Water Heaters
- §40-33 Number and Capacity of Gas-Fueled Heaters
- §40-34 Capacity of Water Heaters
- §40-35 Shut-Off Devices
- §40-36 Gas Piping
- §40-37 Appliances in Sleeping Rooms
- §40-38 Clearances from Combustible Materials
- §40-39 Venting of Gas Appliances
- §40-40 Gas-Fueled Space Heaters Installed Prior to December 18,1957
- §40-41 Gas-Fueled Water Heaters Installed Prior to December 18,1957
- §40-42 Maintenance of Space and Water Heaters
- §40-43 Existing Appliances in Ineligible Locations
- §40-44 [Reserved]
- §40-45 Variations

Ch. 41 Venting of Gas Water Heaters and Other Gas Appliances in Multiple Dwellings

§41-01 Venting of Gas Water Heaters and Other Gas Appliances in Multiple Dwellings

Ch. 42 Entrance Doors, Locks and Intercommunication Systems

§42-01 Entrance Doors, Locks and Intercommunication Systems

Ch. 43 Installation of Security Items in Multiple Dwellings

- §43-01 Installation of Peepholes
- §43-02 Installation of Two 50 Watt Lights at Front Entrance Way
- §43-03 Installation of Viewing Mirrors in Self-Service Elevators
- §43-04 Installation of Lights in Rear Yards, Side Yards, Front Yards and Courts

Ch. 44 Exemptions from Filing Requirements

§44-01 Minor Alterations that do not Require the Filing of Applications and Plans for Building Alteration Permits with the Department of Buildings

Ch. 45 Building Permit Application Procedures

§45-01 Microfilming of Application Folders and Associated Documentation for Temporary and Final Certificates of Occupancy and Letters of Completion

Ch. 46 Authorized Representatives

§46-01 Persons Authorized to Perform Inspections, Tests, Certifications, and Other Functions on Behalf of the Department

Ch. 47 Licensed Oil-Burning Equipment Installers

§47-01 Requirement of a Seal for Use by Licensed Oil-Burning Equipment Installers

Ch. 48 Construction Superintendents

- §48-01 General Provisions
- §48-02 Duties
- §48-03 Registration of Construction Superintendents
- §48-04 Disciplinary Actions
- §48-05 Obligations of Others
- §48-06 Severability

Ch. 49 Outdoor Signs

Subchapter A General Provisions

B Registration of Outdoor Advertising Companies

C Administrative Remedies of the Department Pursuant to Section 26-260(d) of the Administrative Code

D Removal, Storage, and Disposal of Signs and Sign Structures

E Application for Sign Work Permit

Rules and Regulations

Subchapter A General Provisions

- §49-01 Definitions
- §49-02 Obligation to Cooperate with Inquiries
- §49-03 Obligation to Comply with an Order of the Commissioner
- §49-04 Severability

Subchapter B Registration of Outdoor Advertising Companies

- §49-11 Effective Dates
- §49-12 Application for Registration
- §49-13 Term and Fees
- §49-14 Acceptable Type of Security
- §49-15 Sign Inventory to Be Submitted with Registration Application
- §49-16 Non-conforming Signs
- §49-17 Information Required on Signs

Subchapter C Administrative Remedies of the Department Pursuant to Section 26-260(d) of the Administrative Code

- §49-21 Department's Discretionary Power to Revoke, Suspend or Refuse to Renew Registration and Impose Fines Pursuant Section 26-260(d) of the Administrative Code.

Subchapter D Removal, Storage, and Disposal of Signs and Sign Structures

- §49-31 Applicability
- §49-32 Procedure
- §49-33 Disposal of Abandoned Signs and/or Sign Structures

Subchapter E Application for Sign Work Permit

- §49-41 Application Requirements
- §49-42 Accessory Sign Permits
- §49-43 Advertising Signs

Ch. 50 Distributed Energy Resource Standards

- §50-01 Requirements for the Installation of High-Pressure Natural Gas-Fired Microturbine Systems

Ch. 51 Dormitories

- §51-01 Classification of Student Dormitory

Ch. 52 Notification to the Department of Commencement of Work Pursuant to an Earthwork Permit

- §52-01 Notification to the Department of Commencement of Work Pursuant to an Earthwork Permit

Ch. 100

- Subchapter A Administration**
- Subchapter B Enforcement**
- Subchapter D**

Subchapter A Administration

- §100-03 Fees Payable to the Department of Buildings
- §101-01 Definition of Existing Building
- §101-06 Special Inspectors and Special Inspection Agencies
- §101-07 Inspections and Approved Agencies
- §101-10 Final Inspection and Sign-Off Prior to Letter of Completion

Subchapter B Enforcement

- §102-01 Violation Reclassification and Certification of Correction
- §102-02 Compensation of Registered Design Professionals in Accordance with Section 28-216.6 of the Administrative Code

Subchapter D

- §104-08 Qualifications for Site Safety Manager and Site Safety Coordinator Certificates

APPENDIX A Department of Buildings Promulgation of Amendments to Regulations Relating to Public Access to Records

Rules and Regulations

CHAPTER 1 MATERIAL AND EQUIPMENT APPLICATION PROCEDURES

§1-01 Material and Equipment Application Procedures.

(a) *Jurisdiction.* Pursuant to New York City Administrative Code §27-131, all materials which in their use are regulated by the Building Code must be approved by the Commissioner of the Department of Buildings (the "department").

(b) *Filing of applications.* (1) All applications for acceptance of material or equipment which is subject to the approval of the Commissioner shall be submitted to the department on forms so provided and labeled "Attention: Material and Equipment Acceptance Division" ("MEA").

(2) A complete application shall consist of a transmittal letter addressed to the commissioner, and the appropriate application fee together with all test reports and information required in the application and, on matters involving reference standards RS 7-3, 8-1, 13-1, 13-3, 13-6, 13-16, Sections p 102.4(b)(5), p 105.4, p 114.12 and p 115.8 of 16, 17, 18-1, 19-1 and paint spray booths, an affidavit attesting that a complete application has been served on the Fire Commissioner of the City of New York, Bureau of Fire Prevention, Technology Management Unit, in the same manner service is made on the department. An application, accompanied by the required fee, will be assigned a filing number. Any application which is not submitted with all information and test reports within sixty (60) calendar days of initial filing will be administratively closed. The application fee shall be non-refundable.

(c) *Applications filed with MEA and thereafter abandoned.* Applications for acceptance, which have been disapproved in whole or in part, and upon which no further action has been taken by the applicant within one year after the notice of disapproval is given shall be processed as follows:

- (1) The application shall be deemed abandoned.
- (2) The applicant shall be notified, by certified by mail at the address last furnished, that the application has been deemed abandoned and that he or she has the opportunity to remove reports and other information from the application, exclusive of the application forms, within 21 days of the date of the said notification.
- (3) Upon completion of such 21 day period, applications and remaining reports and other supplementary information may be removed from the files and destroyed.
- (4) Except for matters requiring consultation with the fire department, the Director of MEA may vary the procedure as may be necessary to avoid hardship, when same is warranted due to unusual and exceptional conditions beyond the control of the applicant.

(d) *Fees.* The fees for an application for the approval of material and equipment or an application for the amendment of prior approval of material or equipment shall be pursuant to Administrative Code §26-214 (11).

(e) *MEA review.* MEA shall review all applications for acceptance of material or equipment for which there is a code prescribed test method or a recognized test method acceptable to the commissioner and shall approve or deny such application on behalf of the commissioner. No material or equipment application which is required to be forwarded to the fire department pursuant to §1-01(b)(2) shall be approved unless comments have been received from the fire department or

fifteen (15) business days have elapsed from the time of filing of the complete application with the department, whichever is sooner.

(f) *Advisory committee review.* The commissioner shall appoint an advisory committee consisting of members of the department, the fire department, a registered architect, a professional engineer and representatives of the building and construction industry. The advisory committee shall be chaired by the Deputy Commissioner for Technical Affairs.

(1) *Absence of a code prescribed test method or an acceptable recognized test method.* In the event there is neither a code prescribed test method nor an acceptable recognized test method for material or equipment whose approval is under the jurisdiction of the department, an application for such material or equipment approval shall be referred to the advisory committee. The advisory committee shall prepare for the commissioner a detailed report and recommendation which sets forth the basis for approval or denial of the material or equipment application. In addition, on applications involving RS 5, where there is neither a code prescribed test method nor an acceptable recognized test method, the department shall be responsive to fire safety concerns and shall forward such applications to the fire department as appropriate.

(2) *Conflicting or ambiguous test results.* In the event MEA determines that submitted test reports are conflicting or ambiguous, MEA may refer the application to the advisory committee. The advisory committee shall prepare a detailed report and recommendation to the commissioner which sets forth the basis for approval or denial of the material or equipment application for which MEA found conflicting or ambiguous test results. Where necessary, the advisory committee may request the submission of additional information.

(3) *Consultation with the fire department.* The commissioner shall not take any final action in approving material or equipment applications which are required to be submitted to the fire department, pursuant to §1-01(b)(2), unless comments have been received from the fire department or fifteen (15) business days have elapsed from the date of the advisory committee's recommendation to the commissioner, whichever is sooner.

(g) *Appeals.* (1) Any denial by MEA may be referred to the advisory committee for its recommendation, upon applicant's written request within thirty (30) calendar days of the denial. The advisory committee shall issue a detailed report and recommendation to the commissioner who shall issue a final determination.

(2) A denial by MEA shall not be deemed a final determination of the Department until thirty (30) calendar days have lapsed.

(3) The final determination shall state the basis for the determination, with specific reference to test methods and test results.

(4) An applicant may challenge a final determination of the commissioner by initiating an article 78 proceeding in State Supreme Court.

(h) *Amendments.* All amendments to material or equipment applications previously approved by the MEA or the Board of Standards and Appeals, including amendments relating to a manufacturer's name or to the material, or equipment design, shall be processed in the same manner as any new application.

Rules and Regulations

CHAPTER 2 BOILER INSPECTIONS

§2-01 Low Pressure Boiler Inspections by Qualified Boiler Inspectors and Welding Repairs by Certified Welders.

(a) *Definitions.*

Authorized insurance company. A company approved by the New York State Department of Labor.

Qualified boiler inspector.

(1) An inspector who has been issued a Certificate of Competence by the New York State Department of Labor and who is employed by an Authorized Insurance Company

(2) A licensed New York City High Pressure Boiler Operating Engineer

(3) A licensed New York City Class A and B Oil Burning Equipment Installer

(4) A licensed New York City Master Plumber

(5) A Journeyman Plumber acting under the direct and continuing supervision of a New York City Master Plumber

Certified welder.

(1) An organization in possession of a valid National Board or New York State Repair Certificate of Authorization

(2) An organization in possession of a valid American Society of

This space intentionally left blank

Rules and Regulations

Mechanical Engineers ("ASME") Certificate of Authorization

(b) *Boiler identification and records.*

(1) The owner of a boiler or any other person acquiring a new or replacement boiler shall file the forms as shown in the instructions for "Boiler Filing Submission for Replacement, Repair, Installation or Legalization," where required.

(2) The Department of Buildings boiler number is to be affixed to the boiler by a non-combustible tag, painted on the boiler, or clearly visible and appropriately displayed in close proximity to the boiler.

(3) The Department of Buildings boiler numbers are to be used in all correspondence between qualified boiler inspectors and the Department. Boiler numbers can be obtained in any one of the borough offices via the public access terminals.

(4) The owner of a boiler is to notify the Department of Buildings Boiler Division within 30 days of the owner's change of address. The Department of Buildings boiler number is to be used in all correspondence.

(c) *Inspection and filing requirements.*

(1) All low pressure boiler annual inspection reports by qualified boiler inspectors shall be submitted on forms supplied by the Department of Buildings within 30 days following the inspection.

(2) "Low Pressure Boiler Annual Inspection Reports" are to be submitted with a \$30.00 filing fee to the Department of Buildings.

(3) If an inspection reveals any dangerous condition in a boiler which threatens life or safety and which requires an immediate shut down of the boiler, the qualified boiler inspector must send immediate notification of the condition to the Chief Boiler Inspector at the Department of Buildings at the address provided in the City's website, <http://www.nyc.gov>.

(d) *Revocation of qualified boiler inspector's authorization to submit boiler inspection reports to the department.*

(1) qualified boiler inspector's failure to comply with any of these rules or a qualified boiler inspector's falsification of any form or inspection report filed with the Department may result in revocation of authorization to submit boiler inspection reports to the Department, pursuant to Rule 13-11 of Title 1 of the Rules of the City of New York (1 RCNY §13-01).

(e) *Low pressure boiler welding repairs.*

(1) All low pressure boiler welding repairs shall be performed by certified welders, as required by the New York State Industrial Code Rules 4-6.2 (12 NYCRR 4-6.2) and 14-3.2 (12 NYCRR 14-3.2).

(2) All welded repairs must have a metal tag attached to the weld. The metal tag shall list the name of the certified welder, the certified stamp number of the certified welder and the date of the welded repair.

(f) *Failure to comply.*

(1) The failure to comply with requirements relating to boiler inspections and welding repairs may result in the issuance of a notice of violation and related enforcement proceedings.

§2-02 Reduction of Penalties for Late Filing of Annual Low Pressure Boiler Inspection Reports.

(a) Pursuant to Section 27-793(c) of the New York City Administrative Code ("the code"), each owner of a boiler that is subject to periodic inspection must file with the Department an annual statement accompanied by a qualified boiler inspector's signed report of a boiler inspection. The first report must be filed within thirty (30) days of the installation of a new boiler. Thereafter, such report must be filed on or before

December 31 of the year of each annual inspection.

(b) Penalties for the late filing of reports listed in (a) above are set forth in Section 26-125(d) of the code. Pursuant to Section 26-125(e) of the code, such penalties may be reduced in cases where [*sic*] sufficient evidence is submitted to prove that the required annual inspection was performed prior to December 31 of the year for which the inspection report was due or within thirty (30) days of initial installation but the inspection report was filed late. This rule sets forth the procedures that must be followed to obtain a reduction of penalties for the late filing of annual boiler inspection reports pursuant to Section 26-125(e).

(c) All requests for the reduction of penalties for the late filing of annual boiler inspection reports must be made in writing and accompanied by the supporting evidence listed in paragraphs (d) and (e) below. The requests must be addressed to the Department of Buildings, Boiler Division at the address provided in the City's website, <http://www.nyc.gov>.

(d) All requests for a reduction in penalties must be accompanied by a copy of the inspection report and by a notarized statement from the qualified boiler inspector who performed the inspection or from the authorized insurance company whose employee performed the inspection indicating the date that the required annual boiler inspection was performed. If the boiler inspection was performed by a licensed New York City Oil Burner Equipment Installer or a licensed New York City Master Plumber, the statement must contain the seal of the licensee.

(e) In addition to the statement listed in paragraph (d) above, additional evidence must be submitted to prove the date of inspection. Examples of such evidence include but are not limited to the following:

- (1) Invoices for completed inspections;
- (2) Canceled checks to qualified boiler inspectors for completed inspection;
- (3) Route sheets of inspectors employed by authorized insurance companies indicating dates and addresses of inspections;
- (4) Receipts of payment for completed inspections; and
- (5) Executed contracts with authorized insurance companies and other qualified boiler inspectors indicating dates of inspection.

CHAPTER 3 VACANT AND UNGUARDED BUILDINGS

§3-01 Sealing and Protection of Vacant and Unguarded Buildings.

Where buildings are vacant, unguarded, open to unauthorized entry and are required to be sealed pursuant to the provisions of an unsafe building order issued by the Department of Buildings or a determination by the Department of Housing Preservation and Development that the condition is dangerous to life, health and safety, they shall be sealed and protected in the following manner:

(a) *Buildings with exterior walls constructed of brick or other masonry.*

(1) All exterior openings including door openings, which are in the cellar, basement and first story, or which are less than ten (10) feet from grade, shall be sealed with concrete block or stucco on plywood as provided below. All exterior openings which are on the course of a fire escape or are above the first

Rules and Regulations

story and less than six (6) feet measured horizontally from an opening in an adjoining building shall be sealed with concrete block or stucco on plywood as provided below. One door opening, readily visible from the street, may, at the discretion of the owner, be sealed with a padlocked metal roll-up door, one (1) hour fire rating metal door or an exterior door of one (1) and three-quarter (3/4) inch solid wood covered with twenty six (26) U.S. gage [sic] galvanized metal with edging turned over and nailed with flat head galvanized nails. The door of solid wood shall be hung in such a manner that no screws are exposed on the outside of the door on either the hinges or the hasps. Hinges shall not have removable hinge pins. Two hasps and locks shall be provided, located so as to divide the height of the door in equal sections.

(2) Concrete Block Seal.

(i) Concrete block shall conform to the provisions of Reference Standard RS-10 of the New York City Building Code.

(ii) All door and window frames shall be removed before concrete blocks are installed. Brickwork which new concrete blocks will abut, shall be cleaned and thoroughly wetted before blocks are installed.

(iii) Doors and windows, not exceeding three (3) feet in width, shall be sealed with concrete block at least four (4)

inches in thickness. Openings exceeding three (3) feet in width shall be sealed with concrete blocks at least eight (8) inches in thickness.

(iv) Concrete blocks shall be laid in masonry cement mortar with a mix of not more than three (3) parts of sand for each part of masonry cement by volume. Joints in masonry shall be broken and exterior faces shall be struck. Blocks shall not extend beyond the brick line. Masonry cement shall conform to the provisions of Reference Standards RS-10 of the Building Code.

(3) *Stucco on Plywood Seal.* (i) If the window frame is in a condition whereby plywood can be secured to it, five-eighths (5/8) inch CDX grade plywood shall be nailed into such frame openings with eight d (8d) common nails every twelve (12) inches. Galvanized wire lath [sic] shall then be nailed to plywood using one (1) inch roof nails every twelve (12) inches. Wire lath [sic] shall be covered by an one (1) inch coat of portland cement with a float finish. Cement shall not extend beyond the opening's brickline.

(ii) If a window or door frame is in a condition whereby such plywood cannot be secured to it, the frame shall be removed. The opening shall then be framed-out with new grade one (1) wood or metal two (2) x four (4) inch top and bottom plates with wood or metal studs every sixteen (16) inches on center.

(iii) Openings exceeding three (3) feet shall be framed-out

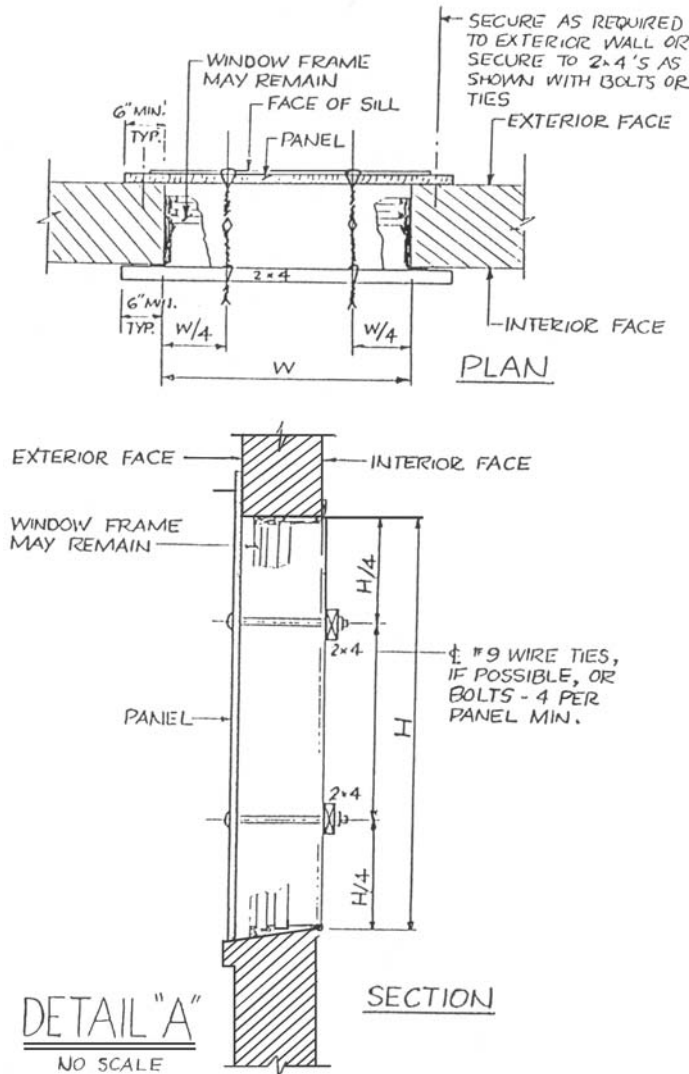

ALTERNATE METHOD OF SECURING PANELS TO WINDOW OPENINGS, SIMILAR FOR OTHER OPENINGS.

Rules and Regulations

with new grade one (1) two (2) x four (4) inch top and bottom plates with wood or metal studs every sixteen (16) inches on center.

(b) *Buildings with exterior walls constructed of material other than masonry.* All exterior openings including door openings, which are in the cellar, basement and first story, on the course of a fire escape, are less than six (6) feet measured horizontally from an opening in an adjoining building or which are less than ten (10) feet from grade, shall be sealed with stucco on plywood as provided in this section or with five-eighths (5/8) inch CDX grade plywood which may be nailed directly to the window frame if such frame is in a condition that will enable such plywood to be attached, fastened directly to the exterior wall, or secured with bolts and battens in accordance with Detail "A" (annexed below). If such frame is not in a condition to enable such plywood to be attached, the opening shall be framed-out with new grade one (1) wood or metal two (2) x four (4) inch top and bottom plates with wood or metal studs every sixteen (16) inches on center. One door opening, readily visible from the street, may, at the discretion of the owner, be sealed with a padlocked metal roll-up door, one (1) hour fire rating metal door or an exterior door of one (1) and three-quarter (3/4) inch solid wood covered with twenty six (26) U.S. gage [*sic*] galvanized metal with edging turned over and nailed with flat head galvanized nails. The door of solid wood shall be hung in such a manner that no screws are exposed on the outside of the door on either the hinges or the hasps. Hinges shall not have removable hinge pins. Two hasps and locks shall be provided, located so as to divide the height of the door in equal sections.

(c) *Openings in roofs which are accessible from an adjoining building shall be sealed as follows:*

(1) Ventilating equipment and similar protruding structural elements in roofs shall be completely removed, except that dumbwaiter shafts extending above roof level need not be removed if the door opening into the shaft is sealed with concrete blocks or stucco on plywood. Openings remaining after removal of such equipment and/or protruding structural elements shall be sealed with one (1) inch thick tongue and groove boards, not less

(8)-inch joists, not more than sixteen (16) inches on center. Joists shall be secured to the roof timbers framed about the openings in a sound and secure manner. Boards shall be covered with ninety (90) pound roofing felt secured by one (1) inch roofing nails every twelve (12) inches or roofing cement to provide a watertight durable cover. Skylights at the top of the dumbwaiter shafts shall be sealed by removing the assembly, framing out the opening with new grade one (1) two (2) x four (4) inch joists on edge, sixteen (16) inches on center and then covered with five-eighths (5/8) inch CDX grade plywood. Such plywood shall then be covered with ninety (90) pound roofing felt secured by one (1) inch roofing nails every twelve (12) inches or roofing cement to provide a watertight durable cover.

(2) Roof skylights shall be secured by constructing a frame which encloses all sides of the skylight. The frame shall be constructed using new grade one (1) two (2) x four (4) inch single bottom plate and double top plate with wood or metal studs every sixteen (16) inches on center. Bottom plates shall be nailed to the building's roof joists with sixteen d (16d) common nails or sixteen d (16d) concrete nails every twelve (12) inches. Top plates shall overlap at the corners. New grade one (1) two (2) x six (6) inch joists on edge with headers, every sixteen (16) inches on center, shall bear on top plates. The entire frame shall then be covered with five-eighths (5/8) inch CDX grade plywood. A watertight durable cover shall be provided on the top of the frame using (90) pound roofing felt secured by one (1) inch roofing nails every twelve (12) inches or roofing cement. A diagram for enclosure of roof skylight is provided at Detail "B" below.

(3) Public hall roof bulkheads shall be sealed as follows: Windows of bulkheads shall be removed and sealed with concrete blocks or stucco on plywood as provided in this section. Doors of bulkheads may be secured shut if the frame and door are in a condition whereby the door may be adequately secured. If not in such condition, the door and frame shall be removed and the opening shall be sealed with concrete blocks or stucco on plywood as provided in this section.

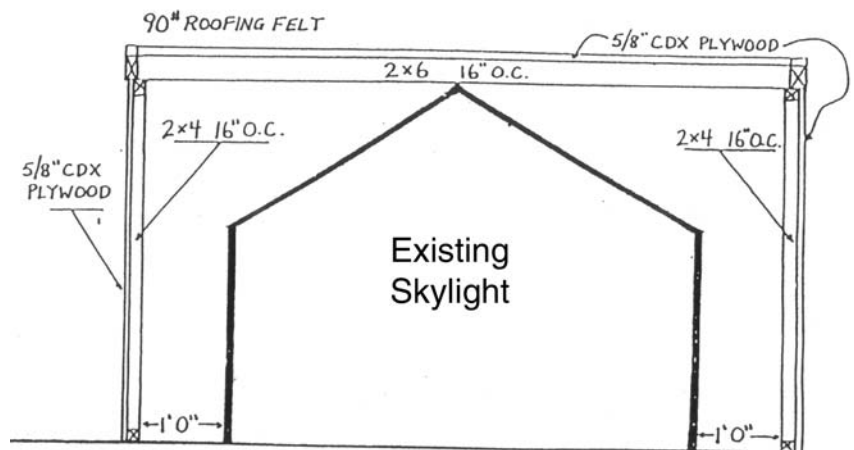

Detail "B"
Enclosure For Roof Skylights

than six (6) inches in nominal width or with five-eighths (5/8) [*sic*] inch CDX plywood, nailed onto three (3)-inch by eight

Openings at top of roof bulkheads shall be sealed by removing the assembly, framing out the opening with new grade one (1)

Rules and Regulations

two (2) x eight (8) inch joists on edge, sixteen (16) inches on center and then covered with five-eighth (5/8) inch CDX grade plywood. Such plywood shall then be covered with ninety (90) pound roofing felt secured by one (1) inch roofing nails every twelve (12) inches or roofing cement to provide a watertight durable cover.

(d) *Notification to Utilities.* Notification shall be made to the steam, electric and gas utility companies which provide service to the buildings to request discontinuance of service to the buildings. In addition, water service to the building shall be discontinued and certification to that effect from the Department of Environmental Protection shall be filed with the department.

(e) *Rubbish Removal and Examination.* Prior to the completion of sealing of exterior openings as set forth in this section, all decomposable debris and rubbish shall be removed from the yards, courts and any area at the perimeter of the premises and the building shall be treated to exterminate rodents by a licensed exterminator.

(f) *Hazardous Combustible Material Within Buildings.* If hazardous materials which could cause a fire or explosion are discovered within the building, they shall be removed and disposed of in an appropriate manner prior to sealing.

§3-02 Obtaining Access to Keys of Sealed Premises.

(a) *Submission of Request.*

Persons wishing to have access to the keys to a premises sealed by the Department of Buildings must appear in person at the Executive Offices of the New York City Department of Buildings. At this time they must submit form OP-14, "Request for Access to Sealed Premises," with sections "A - Ownership Interest" and "B - Statement of Intent" both completed and notarized. Copies of the form are available at the Executive Offices of the Department of Buildings.

(b) *Verification of Ownership Interest.*

(1) The General Counsel's Office reviews the form to verify an ownership or leasehold interest in the premises. The person seeking to obtain access must provide the General Counsel's Office with some identification including a photograph (e.g. driver's license, passport) and whatever document establishes the person's ownership or leasehold interest in the premises.

Examples of such documents include the following:

- (i) a copy of a recorded deed;
- (ii) a signed lease, along with the owner's name(s), address(es) and telephone number(s);
- (iii) a mortgage agreement;
- (iv) a State certified Certificate of Incorporation;
- (v) signed partnership documents; and
- (vi) any other document deemed acceptable by the Commissioner.

(2) A representative of the General Counsel's Office will review the above documentation to verify ownership interest. If ownership interest is verified, the representative will sign and date the form where indicated. This representative gives a copy of the signed form to the person seeking to obtain access and gives the original form to the office of Borough Operations.

(c) *Obtaining the Key.*

(1) Once the General Counsel's Office signs the form verifying ownership interest, the person seeking to obtain access must bring the following documents to the Office of the Executive Chief Inspector to substantiate the affirmations required by

subdivision c of Section 26-127.1 of the Administrative Code:

- (i) a copy of Form OP-14 signed by the General Counsel's Office;
- (ii) a copy of the computer index sheet listing the application and violations for the premises;
- (iii) a copy of the vacate order;
- (iv) a copy of all relevant outstanding violations;
- (v) a copy of any relevant work permit issued by the Department of Buildings;
- (vi) a copy of all relevant plans approved by the Department; and
- (vii) any other document deemed necessary by the Commissioner.

(2) A representative of the office of the Borough Operations will review the above documentation to determine if the person has the requisite need to gain access to the premises. If it is determined that access should be granted, the representative of the office of the Borough Operations will:

- (i) have a photograph taken of the person seeking to obtain access, initial the photograph and attach it to the form;
- (ii) obtain a copy of the identification including a photograph (e.g. driver's license, passport) and attach it to the form;
- (iii) indicate on the form reasons for granting access;
- (iv) specify on the form the date by which the keys must be returned;
- (v) sign the form; and
- (vi) give a copy of both sides of the completed form to the person receiving the key.

(d) *Returning the key.*

- (1) All keys must be returned to the office of Borough Operations by the date indicated on the form.
- (2) If a vacate order has been rescinded, all locks and chains must be returned with the keys.
- (3) In order to obtain an extension of time for keeping the key, the person seeking access must appear in person at the Executive Offices with a notarized letter stating the reason for this request. A representative from the office of Borough Operations will review the request and, if accepted, will note the new return date on the original form and initial the change. The notarized letter will be attached to the original form.

§3-03 Hearings to determine whether sealing orders were properly issued.

(1) Hearings to determine whether sealing orders were properly issued by the Department of Buildings may be arranged through the General Counsel's office. A person challenging a sealing order may obtain a hearing by submitting a written request to the office of the General Counsel.

(2) The office of Administrative Trials and Hearings (OATH) will be notified to schedule a hearing after the General Counsel's office receives the written request for the hearing. OATH will set the date and time for the hearing. The General Counsel's office will notify the person requesting the hearing as soon as OATH calendars the hearing. In the event that the person seeking the hearing fails to appear, the Commissioner's Order to seal the premises will remain in effect.

3-04 Obtaining Access to Keys of Premises Sealed Pursuant to §26-127.2 of the Administrative Code.

(a) *Submission of Request.* Persons wishing to have access to the keys to a premises sealed by the Department of Buildings

Rules and Regulations

pursuant to §26-127.2 of the Administrative Code must appear in person at the Executive Offices of the New York City Department of Buildings. At this time they must submit the form, "Request for Access to Premises Sealed for Zoning Violations," with section "A - Ownership Interest" and "B - Statement of Intent" both completed and notarized. Copies of the form are available from the Administrative Enforcement Unit ("AEU") at the Executive Offices of the Department of Buildings.

(b) *Verification of ownership interest.* (1) The AEU reviews the form to verify an ownership or leasehold interest in the premises. The person seeking to obtain access must provide the AEU with some identification including a photograph (e.g. driver's license, passport) and whatever document establishes the person's ownership or leasehold interest in the premises. Examples of such documents include the following:

- (i) a copy of a recorded deed;
- (ii) a signed lease, along with the owner's name(s), address(es) and telephone number(s);
- (iii) a mortgage agreement;
- (iv) a State certified Certificate of Incorporation;
- (v) signed partnership documents; and
- (vi) any other document deemed accepted by the Commissioner.

(2) A representative of AEU shall review the above documentation to verify ownership interest. If ownership interest is verified, the representative will sign and date the form where indicated. A copy of the signed form shall be provided to the person seeking to obtain access.

(c) *Obtaining the key.* (1) Once the AEU signs the form verifying ownership interest, the person seeking to obtain access must submit copies of the following documents to the AEU:

- (i) Form entitled "Request for Access to Premises Sealed for Zoning Violations," with section A signed by AEU;
- (ii) the sealing order;
- (iii) any other document deemed necessary by the commissioner.

(2) A representative of the AEU will review the above documentation to determine if the person has the requisite need to gain access to the premises. If it is determined that access should be granted, the representative of the AEU will:

- (i) have a photograph taken of the person seeking to obtain access, initial the photograph and attach it to the form;
- (ii) obtain a copy of the identification including a photograph (i.e. driver's license, passport) and attach it to the form;
- (iii) indicate on the form reasons for granting access;
- (iv) specify on the form the date by which the keys must be returned;
- (v) sign the form; and
- (vi) give a copy of both sides of the completed form to the person receiving the key.

(d) *Returning the key.* (1) All keys must be returned to the AEU by the date indicated on the form.

(2) If a sealing order has been rescinded, all locks and chains must be returned with the keys.

(3) In order to obtain an extension of time for keeping the key, the original person seeking access must appear in person at the AEU with the key and a notarized letter stating the reason for this request and, if accepted, will note the new return date

on the original form and initial the change. The notarized letter will be attached to the original form.

CHAPTER 4 CERTIFICATES OF OCCUPANCY, LIVE LOADS AND OCCUPANCY LOADS

§4-01 Posting Requirements.

(a) A copy of the Certificate of Occupancy indicating the live loads and occupant loads shall be posted within every building for which a Certificate of Occupancy has been issued, except in one and two-family dwellings, and such posted Certificate of Occupancy shall be deemed in full compliance with §27-225 of the Administrative Code. In a commercial or industrial structure for which no Certificate of Occupancy was issued, a sign shall be posted and maintained in a conspicuous place on each floor stating the live loads.

(b) The copy of the Certificate of Occupancy shall be posted in the main entrance hall or lobby leading to the elevator of each building when there are elevators and to the main entrance hall to the stairs when there are no elevators and shall be posted near the main entrance door when there is no entrance hall to stairs or elevators.

(c) The Certificate of Occupancy shall be posted in a frame having a size sufficient to accommodate properly the Certificate of Occupancy.

(d) The frame shall be faced with glass or other transparent facing which will permit the Certificate of Occupancy to be read without difficulty.

(e) Frames shall be constructed of corrosion resistant metal or durable [*sic*] impact and flame resistant plastic.

(f) Frames shall be constructed in such manner as to prevent removal of the facing or the Certificate of Occupancy, without the use of special tools.

(g) Certificates shall be placed in such location as to be readily available to interested persons, and the bottom of the frame shall be located between 54 to 66 inches above the floor.

(h) Sufficient lighting shall be provided to make the Certificate of Occupancy legible at all times when the building is occupied.

(i) In place of posting the Certificate of Occupancy in a location specified under §4-01(b), it may be located as specified in this rule but only in those buildings where there is a resident caretaker or superintendent on the premises or where there is a building manager on the premises and where such caretakers, superintendents or managers or their assistants are present in the building at all times when the building is occupied. In such buildings, the Certificate of Occupancy may be posted within the entrance hall of the apartment or office of the caretaker or superintendent or inside the entrance to an office of a building manager. The Certificate of Occupancy shall be posted in such locations in the manner specified by the foregoing rules.

(j) A diagrammatic plan approved by the Department of Buildings, as required by §27-564 of the Administrative Code, shall be posted in accordance with the requirements for a Certificate of Occupancy indicated in these rules showing:

(1) the weight of any piece of machinery or equipment weighing more than 1,000 pounds and its identifying description and location.

(2) the maximum design wheel load and the total maximum

Rules and Regulations

weight of any vehicle that may be brought into the building.

(3) the equivalent uniform partition loads, or in lieu of this, a statement to the effect that the design was predicated on actual partition loads.

A diagrammatic key plan shall not be required where the above information is clearly noted on the posted Certificate of Occupancy.

Section 4-01(j) shall not apply to any structure or portion thereof erected and altered in compliance with any code in effect prior to December 6, 1968. Notice of the permitted floor loads in such buildings shall be posted as required by the former code.

CHAPTER 5 CONCRETE

§5-01 Conveyance by Pumping Methods.

The specified compressive strength f_c , of concrete conveyed by pumping methods shall not exceed 5,000 pounds per square inch.

(b) *Mix Proportioning.*

(1) All controlled concrete to be pumped shall:

(i) Comply with all provisions of §27-605: Mixes

(ii) [*sic*] Normal and Heavyweight Concrete to [*sic*] be proportioned in accordance with ACI 211.1-74, utilizing Table 1.

Table 1. Volume of Coarse Aggregate per Unit of Volume of Concrete¹

| Maximum size of aggregate | Volume of dry-rodged coarse aggregate per unit. Volume of concrete for different finness** Moduli of Sand ² | | | |
|---------------------------|--|------|------|------|
| | 2.40 | 2.60 | 2.80 | 3.00 |
| 3/8 | .475 | .456 | .437 | .418 |
| 1/2 | .561 | .542 | .523 | .504 |
| 3/4 | 6.27 | .608 | .509 | .570 |
| 1 | .675 | .656 | .637 | .617 |
| 1 1/2 | .712 | .693 | .675 | .655 |
| 2 | .741 | .722 | .703 | .684 |
| 3 | .779 | .760 | .741 | .722 |

1. Values established at Median-Point (reduced 5%). See footnote Table 5.3.6 ACI 211.1-74.

2. The type and gradation [*sic*] of the course aggregate, delivery system and job conditions may require these values to be varied. However in no event shall the variations exceed the maximum allowance noted in ACI 211.1-74 Table 5.3.6.

(iii) For sand lightweight concrete [*sic*] proportioned in accordance with ACI 211.2.-69 utilizing Table 2 except that the air dry unit weight of the concrete may exceed 115 lb. per cu. ft. when tested at age 56 days in accordance with procedure in ASTM C 567.

Table 2. Volume of Coarse Lightweight Aggregate per Cubic Yard of Concrete¹

| Maximum size lightweight aggregate, in | Fineness Module of Natural Sand Course* aggregate cu. Ft. per yard ² | | | |
|--|---|------|------|------|
| | 2.40 | 2.60 | 2.80 | 3.00 |
| 3/8 | 9.3 | 8.9 | 8.5 | 8.1 |
| 1/2 | 11.1 | 10.7 | 10.3 | 9.9 |
| 3/4 | 13.2 | 12.8 | 12.4 | 12.0 |

Notes:

¹ Volumes are based upon lightweight aggregate at a total moisture content of 8 percent in loose conditions as described in ASTM C29.

² These values may be increased based upon the type, gradation [*sic*] and moisture content of the aggregates, delivery system and job conditions.

2) (i) The type, gradation [*sic*] and moisture content of the aggregate delivery system and job conditions may affect the slump necessary at the mixer for the proper conveying of the concrete. For these reasons in addition to the recommended mix established from the preliminary trial mix data obtained in accordance with §27-605(a)(2), two alternate mixes also shall be recommended. These alternate mixes shall be based upon the water cement ratio curve in the preliminary test data to produce concrete having slumps greater than the maximum specified in §27-605(a)(2) in increments of 1-inch for concrete manufactured with gravel or stone aggregate but [*sic*] not to exceed 8 inches or increments of 2 inches for concrete manufactured with lightweight aggregates but not to exceed 9 inches.

(ii) It shall be permissible to use these mixes interchangeably during the course of the work, providing the slump at [*sic*] the mixer is equal to or less than that provided for the applicable recommended mix.

(iii) The recommended preliminary trial mix shall indicate the design unit weight in lbs. per cu. ft. of the fresh concrete and the estimated air dry unit weight at 56 days.

(c) *Testing and inspection of controlled concrete.*

(1) Those samples of concrete for test purposes required by RS-10-3, §4.3.1. which are designated to be "taken out of the bucket, hopper or forms" shall be obtained by passing a receptacle completely through the discharge stream of the delivery line or by completely diverting the discharge into a container. Transport the sample concrete to the place where fresh concrete tests of slump, air content, temperature and unit weight are to be performed and where specimens for strength tests are to be molded in accordance with RS-10-51 and RS 10-52 as directed by the Architect or Engineer designated for controlled concrete inspection. Each of the foregoing three (3) test cylinders per one hundred and fifty (150) cubic yards required under §4.3.1 of RS 10-3 shall be taken from a different delivery vehicle.

(2) Where the concrete is discharged directly into the forms by pumping methods the slump taken at the end of the delivery line shall be used to determine conformance with the slump specified for the work.

(3) The results of tests of samples taken at the end of the pump delivery line shall be shown on the same report with corresponding tests of samples taken from the same batch at the mixer.

(4) (i) Included in the duties of the on-site inspector as provided by §27-607 shall be:

(A) That water is added only to the mixer or under the following circumstances to the hopper of the pump:

When a portion of the concrete is discharged from the mixer into the pump hopper at a slump below that specified in the preliminary trial mix and too low for pumpability, water may be added to this concrete in the pump hopper to bring it to the specified slump provided all pumping action is stopped. Before pumping is resumed the concrete in the hopper must be thoroughly re-mixed for a minimum period of 2 minutes after all of the water has been added. If the concrete cannot be properly re-mixed it shall be removed from the hopper and discarded.

The balance of the batch in the mixer shall be adjusted to the specified slump before further discharge.

Rules and Regulations

(B) Examination of the conveying line for leakage of cementitious material.

(C) Verify that no aluminum pipe is used.

(ii) Included in the duties of the batch plant inspector as provided for in §27-605(a).

(5) A.B., shall be:

(i) To make adjustments for variations in fineness modulus of the fine aggregate as per ASTM C 33, Section 3.4. When the difference of fineness modulus of the fine aggregate is more than 0.2 for each 0.2:

(A) Below the Design Fineness Modulus deduct 50 lbs. from the dry batch weight of the fine aggregates and add 50 lbs. for normal weight (20 lbs. lightweight) to the dry batch weight of the coarse aggregates.

(B) Above the Design Fineness Modulus add 50 lbs. to the dry batch weight of the fine aggregate and deduct 50 lbs. for normal weight (20 lbs. lightweight) from the dry batch weight of the coarse aggregates.

(ii) To test lightweight aggregates for total moisture content each day before the first concrete for the project is batched and thereafter at appropriate intervals during the day or whenever a moisture change may be evident. The moisture content of each test shall be reported on the corresponding inspection ticket accompanying each load of concrete.

(iii) To immediately notify the concrete producer and the contractor when the total moisture content of the lightweight aggregate [*sic*] is 8 percent or less, that a change to an alternate mix may be necessary to maintain the water cement ratio and the slump specified for the work as determined at the end of the delivery line.

(d) *Job Practices.*

(1) Slump shall be maintained as uniformly as possible from batch to batch in conformance with the specified slump.

(2) Delivery systems shall be in good condition. No dented or worn thin section shall be used.

(3) All connections shall have clean grooves, be equipped with gaskets and securely coupled except at the end of the system where sections are being reconnected gaskets may be omitted.

(4) All vertical risers shall be straight and firmly secured. Pipe bends shall also be restrained against movement caused by the pumping action.

(5) Clean out procedures shall assure that there is no uncontrolled ejection of concrete or clean out devices at the end of the delivery line. If pressure water is used for cleanout, care shall be taken that the water is not deposited into the form.

(6) Care shall be taken that portland cement and sand slurry used to prime the delivery line shall not be deposited in the form without the approval of the architect or engineer designated for Controlled Inspection. All other types of printing liquids shall not be permitted to be placed in the form.

(7) Pumping aids, coloring agents, and all other admixtures shall be permitted only when included in the preliminary trial mix design.

(8) Flexible hose, used in the system shall be handled so as to permit the full flow of the concrete without restriction, reduction of cross sectional area of kinking.

(9) Free hanging, coupling connected sections of flexible delivery line shall have additional restraint between each section across each joint.

(10) Personnel shall avoid standing close to the outlet end of the concrete pump.

(e) *Quality Control.*

(1) The engineer who designed the structure shall specify on his plans, or an amendment thereto, that concrete may be conveyed by pumping.

(2) The placement of concrete by pumping shall be suspended on any project where required test reports are not submitted to the Borough Superintendent within six weeks from the date of placement and sampling.

§5-02 Licensing of Concrete Testing Laboratories.

(a) *General.* (1) Each laboratory shall have in responsible charge a Director who shall be professionally qualified and who shall personally supervise all technical functions of the laboratory relating to testing of concrete and concrete materials. Sections 27-605 and 27-607 of the Administrative Code require that a licensed Professional Engineer or a Registered Architect supervise the testing of materials and the inspection of concrete construction.

(2) All technicians shall be qualified to perform all tests they may be required to conduct under the supervision of the Director.

(3) The laboratory shall annually furnish to the Department of Buildings a list of all personnel who are supervising and performing tests and their qualifications.

Note: §502(b)(6) shall also be complied with.

(4) The laboratory shall furnish to the Department of Buildings a list of all the equipment used to perform tests on concrete and concrete materials.

(5) The laboratory shall request and have an inspection made of its procedure and equipment by the "Cement and Concrete Reference Laboratory" whenever the "Cement and Concrete Reference Laboratory" is inspecting laboratories in this area on its cyclical tour of inspection. These inspections shall be made at the cost and expense of the laboratory seeking a license. A copy of the inspection report shall be promptly submitted to the Department of Buildings.

(6) The laboratory shall correct within 10 days any condition ordered by the Department of Buildings which in its judgement may adversely affect the results of any test.

(7) A license shall be issued to each applicant upon proof of compliance with these rules and upon payment of a fee of one hundred dollars (\$100).

(8) The annual renewal fee shall be fifty dollars (\$50).

(9) A violation of any of these rules or the falsifying or misrepresentation of any fact in any required report shall constitute cause for revocation or suspension of the license by the Commissioner, after a hearing upon prior notice of at least ten calendar days. However, notwithstanding the foregoing, when the public safety may be imminently jeopardized or when false report has been made, the Commissioner shall have the power, pending a hearing and determination of charges, to forthwith suspend the license for a period not exceeding five working days. The presence of batch tickets at a plant filled in on any day other than the day the specific batch is to be delivered to the construction site, whether signed or unsigned, shall constitute a false report.

(10) All reports submitted by the laboratory shall bear its name and its license number.

(11) Renewal of licenses or certificates of qualification, heretofore issued, and issuance of new licenses shall be conditioned upon and subject to the provisions of §§26-131 through 26-139 and 26-

Rules and Regulations

200 through 26-204 of the Administrative Code.

(12) The laboratory shall display a copy of its license on its premises.

(13) The Director shall furnish all of his employees an identification card with a photograph of the employee affixed thereto.

(14) The Director shall maintain a daily record of the activities of all of his employees, indicating the time of departure to and return from batch plant or construction site inspections, the construction project to which the employee is assigned, and the batch plant visited. This record shall be maintained for 2 years and shall be made available to the department personnel.

(b) *Personnel.*

(1) The Director shall be qualified by virtue of education and experience to supervise all tests of concrete and concrete materials conducted by the laboratory. He shall be qualified to practice Professional Engineering or Architecture in the State of New York.

(2) All technicians performing tests on the chemical composition of cement shall be qualified analytical chemists.

(3) All other technicians, field personnel, and all personnel having direct supervision of technical staff shall be qualified by education and experience to take samples and perform required tests. Qualifying education and experience may include a degree in engineering, suitable experience in concrete construction, suitable training in concrete industry sponsored programs and the like.

(4) Satisfactory proof of such qualifications for concrete field testing technicians shall include certification resulting from the ability to pass a qualification test following the guidelines of the American Concrete Institute as set forth in ACI publication CP-2(82).

(5) All concrete field testing technicians shall be qualified pursuant to §5-02(b)(4) on or before July 1, 1985.

(6) The Department of Buildings shall annually publish in the City Record, on or before the first of July, a listing of concrete field testing technicians qualified pursuant to §5-02(b)(4).

(7) The Director shall submit to the department an affidavit that all technicians and field personnel are qualified to perform their designated tasks and shall keep on the premises a record of the qualifications of all personnel, which shall be made available to the department upon request.

(c) *Reports.* Reports shall be presented in a form acceptable to the Department of Buildings.

(d) *Tests.*

(1) The following specifications of the American Society for Testing and Materials (ASTM) shall be considered as part of these rules:

- C29-78 Test for Unit Weight and Voids in Aggregate.
- C31-85 Methods of Making and Curing Concrete Test Specimens in the Field.
- C39-84 Test Method for Compressive Strength of Cylindrical Concrete Specimens.
- C40-84 Test Method for Organic Impurities in Fine Aggregates for Concrete.
- C42-84a Methods of Obtaining and Testing Drilled Cores and Sawed Beams of Concrete.
- C70-79 Standard Method of Test for Surface Moisture in Fine Aggregate.

C88-83 Test Method for Soundness of Aggregates by Use of Sodium Sulfate or Magnesium Sulfate.

C109-86 Test Method for [*sic*] Compressive Strength of Hydraulic Cement Mortars (Using 2-inch or 50 cube Specimens).

C114-85 Method of Chemical Analysis of Hydraulic Cement.
C115-79b Standard Method of Test for Fineness of Portland Cement by the Turbidimeter.

C117-84 Test Method for Material Finer than 75-um (No. 200) Sieve in Mineral Aggregates by Washing.

C127-84 Test Method for Specific Gravity and Absorption of Coarse Aggregate.

C128-84 Test Method for Specific Gravity and Absorption of Fine Aggregate.

C136-84a Method for Sieve Analysis of Fine and Coarse Aggregates.

C138-81 Standard Method of Test for Unit Weight, Yield and Air Content (Gravimetric) of Concrete.

C143-78 Test Method for Slump of Portland Cement Concrete.

C151-84 Test Method for Autoclave Expansion of Portland Cement.

C172-82 Method of Sampling Fresh Mixed Concrete.

C173-78 Standard Method of Test for Air Content of Freshly-Mixed Concrete by the Volumetric Method.

C183-83a Method of Sampling and Acceptance of Hydraulic Cement Mortar.

C184-83 Test for Fineness of Hydraulic Cement by the 150-um (No. 100) and 75-um (No. 200) Sieves.

C187-86 Test Method for Normal Consistency of Hydraulic Cement.

C190-85 Test Method for Tensile Strength of Hydraulic Cement Mortars.

C191-82 Test Method for Time of Setting of Hydraulic Cement by Vicat Needle.

C192-81 Method of Making and Curing Concrete Test Specimens in the Laboratory.

C204-84 Test Method for Fineness of Portland Cement by Air Permeability Apparatus.

C230-83 Specification for Flow Table for Use in Tests of Hydraulic Cement.

C231-82 Standard Method of Test for Air Content of Freshly-Mixed Concrete by the Pressure Method.

C260-86 Specification for Air-Entraining Admixtures for Concrete.

C266-77 Test for Time of Setting of Hydraulic Cement by Gillmore Needles.

C494-86 Specification for Chemical Admixtures for Concrete.

C131-81 Resistance to Abrasion of Small-Size Coarse Aggregate by Use of Los Angeles Machine.

C535-81 Resistance to Degradation of Large-Size Coarse Aggregate by Abrasion and Impact in the Los Angeles Machine, Test for

C803-82 Penetration Resistance to Hardened Concrete, Test for

E4-83a Practices for Load Verification of Testing Machines.

(2) All testing of cement shall be conducted in accordance with the Standard Specifications of the American Society for Testing and Materials (A.S.T.M.).

(e) *Curing and testing of concrete specimens.*

Rules and Regulations

(1) The laboratory shall be equipped with a suitable size enclosed room for the curing of all concrete test specimens. It shall be of such size that specimens can be easily handled during storage and preparation for testing. The room shall be equipped with the necessary equipment to maintain a temperature of 73.4 degrees \pm 3.0 degrees F. at all times, as per A.S.T.M. C-192. The room also shall be equipped to maintain a relative humidity of 95 percent plus in order that the specimens will be maintained in a moist condition in which free water is on the surface at all times. The test specimen shall not be exposed to a stream of running water.

(2) The laboratory shall have equipment for determining relative humidity and temperature of the room and recording devices to monitor them.

(3) The laboratory shall be equipped with a power operated testing machine with a variable speed control. It shall be of sufficient capacity and capable of applying load without shock at a rate of loading prescribed in §4(b) of A.S.T.M. C-39.

(4) The testing machine shall be equipped with two steel bearing blocks with hardened faces, one of which is a spherically seated block that normally will bear on the upper surfaces of the specimen and the other a plain rigid block on which the specimen will rest. The bearing faces of these blocks used for compression testing of concrete shall have a Rockwell hardness of not less than 55 HRC. The bearing faces shall be at least as large and preferably slightly larger than the surface of the specimen to which the load is applied. The bearing faces when new shall not depart from a plan by more than 0.0005-inch at any point and they shall be maintained within a permissible variation limit of 0.001-inch. The movable portion of the spherically seated block shall be designed so that the bearing face can be rotated freely and tilted through small angles in any direction.

(5) The machine, if hydraulic, shall be equipped with a dial gauge having a sufficient diameter to allow the increments of load to be read within plus or minus 1/2 percent of the load being applied.

(6) The machine shall show a certificate of calibration or verification within the time limits set by requirements of A.S.T.M. E-4. If any major repairs have been made on the testing machines, the machine shall be re-calibrated.

(f) *Equipment.* The laboratory shall provide and maintain in proper working condition the following equipment as a minimum requirement:

(1) Necessary for concrete mix designs:

(i) Concrete mixer

(A) 1 1/2 cubic foot capacity

(B) 3 1/2 cubic foot total drum volume

(ii) Slump cone 8-inches in diameter at the base and 4-inches at the top of a height of 12-inches and conforming to A.S.T.M. C143.

(iii) A tamping rod consisting of a round, straight steel rod 5/8-inch in diameter.

(iv) Cylindrical metal measures of 1/2 cubic foot and a cubic foot capacity conforming to the requirements of A.S.T.M. C138.

(v) A sturdy, flat plate about 15-inches square for striking off the concrete in the measure.

(vi) Appropriate air meter.

(vii) Necessary scoops, wood floats, trowels.

(viii) A balance or scale sensitive to 0.1 pound, having a capacity of not less than 100 pounds.

(1) Necessary equipment for preparation of concrete test cylinders:

(i) for compression tests:

(A) Capping plates for cement or plaster caps. Plate glass at least 1/4-inch thick, or machined metal plates at least 1/2-inch thick or polished stone plates of suitable materials, such as granite or diabase and at least 3-inches thick. A capping plate shall be at least 1-inch greater in diameter than the specimen.

(B) Capping plates for use with mixtures of sulphur and granular materials, or similar materials and dimensions, recessed to retain the molten mixture.

(C) The surface of any capping plate shall not depart from a plane by more than .002-inch in the diameter of the specimen.

(D) Straight edge and feeler gauges to check planeness of capping plates and caps.

(E) Calipers and rule for checking size of cylinders.

(F) Controlled temperature melting pot if sulphur mixtures are to be used. Mixing pans, scoops, spoons, trowels, spatulas, etc., if cement or plaster caps, are to be used.

(G) Appropriate grinding equipment may be substituted for the capping equipment.

(ii) Materials Required:

(A) For cement or plaster caps, any of the following:

Type I Portland Cement

High Alumina Cement (Lumnite)

Type III Portland Cement

High strength gypsum plasters such as: Hydrostone and Hydrocal White

(Note: Plaster of Paris is not satisfactory).

(B) For sulphur caps either of the following:

Laboratory prepared mixtures of sulphur and granular materials

Proprietary mixtures such as: Vitroband, Leadite, Cylcap, etc.

(Note: See A.S.T.M. C1982 for limitations of various type caps).

(3) Necessary for analysis of fine and coarse aggregates:

(i) Square or round mesh sieves, Pan Nos. 200, 100, 50, 30, 16, 8, 4, 1/4-inch, 3/8-inch, 1/2-inch, 3/4-inch, 1-inch, 1 1/2-inches, 2-inches, 3-inches, 3 1/2-inches, No. 12.

(ii) Sieve shaking equipment.

(iii) Scales:

(A) Gram scale sensitive to at least 0.1 gram.

(B) Gram scale with at least 5,000 gram capacity and sensitive to 1 gram.

(C) Pound scale sensitive to 1/4-ounce.

(D) Steel brush to brush sieves.

(E) Oven-heat continuously between 221 degrees and 230 degrees F.

(F) Containers for holding solutions.

(G) Perforated containers for immersing aggregates in solutions - wire baskets.

(H) Calibrated Volumetric (milliliters) graduate, 500 milliliters capacity.

(I) Conical metal mold 1 1/2-inches diameter at top, 3 1/2-inches diameter at bottom, 2 7/8-inches high.

(J) Tamping rod - 12-ounces, having a flat circular tamping face 1-inch in diameter.

(K) Tamping rod - 5/8-inch diameter, 24-inches length.

(L) Cubic foot cylindrical measure either 1/2 cubic foot, 1/4 cubic foot, 1/3 cubic foot, 1/10 cubic foot or 1 cubic foot.

(M) 500 milliliters flask.

(N) Thermometer - heats over 100 degrees C.

Rules and Regulations

- (4) Necessary for field testing and inspection:
- (i) Thermometer, 0 degrees-200 degrees F.
 - (ii) Scale, 100 lbs. capacity.
 - (iii) 6-inch round by 12-inch long container.
 - (iv) Slump cone and 5/8-inch by 24-inch rod.
 - (v) Air meter.
 - (vi) Rule, 12-inches.
 - (g) *Cement testing.*
- (1) *Introduction.* Cement testing shall be done in laboratories equipped to make the basic tests required for evaluating cement.
- (2) *Division into physical and chemical tests.* These tests are divided into two parts, physical and chemical and all physical test specimens shall be prepared in a room or area where the temperature is controlled within the limits of 20 to 27.5 degrees C. and the humidity at not less than 50 percent.
- (3) Physical test equipment:
- (i) Analytical balance complete with calibrated weights.
 - (ii) Scale of 2,000 gram capacity accurate to 0.1 percent.
 - (iii) Wagner Turbidimeter or Blaine permeability apparatus calibrated with standard cement from the Bureau of Standards.
 - (iv) One 325 mesh sieve as well as 100, 50, 30 and 16 mesh sizes.
 - (v) Electrically driven mixer bowl and paddle.
 - (vi) Flow table and flow mould.
 - (vii) Trowel and tamper for cubes.
 - (viii) Cube moulds and sealing compound.
 - (ix) Autoclave, moulds and comparator with steel reference bar.
 - (x) Vicat apparatus and moulds.
 - (xi) Gillmore needles and glass plates for samples.
 - (xii) LeChatelier flask.
 - (xiii) Supply of graded Ottawa Sand.
 - (xiv) Glass graduates of 100, 150 and 200 ml. capacity.
 - (xv) Cylindrical measure of 400 ml.
 - (xvi) Straight edge and spatula.
 - (xvii) Calibrated testing machine of not less than 30,000 lbs., capacity equipped with spherically seated upper steel block of not more than 3 1/2 inch [*sic*] diameter.
- (4) A.S.T.M. standard tests for cements. Standard tests for cements as required by A.S.T.M. are as follows:
- Fineness
 - Soundness
 - Time of setting
 - Air content of mortar
 - Compressive tests of 2-inch by 2-inch cubes.
- (5) Chemical composition of cement:
- (i) The laboratory shall be equipped with an analytical balance and standard weights, platinum and porcelain crucibles, cassettes, pipettes, etc.
 - (ii) Distilled water and all reagents necessary for the determination of the oxides of silica, iron, aluminum, magnesium, sulphur, calcium, and insoluble residue by one of approved.
 - (iii) All tests shall be performed in a room equipped with fume chamber, gas burners, working benches, by a qualified analytical chemist.
 - (iv) Special tests such as the alkalis of sodium and potassium shall be made as outlined by the A.S.T.M.

§5-03 Approval of Prequalified Concrete Mixes.

(a) *Source of concrete.*

Concrete proportioned according to prequalified mixes shall be produced only from batch plants, approved by the

Commissioner pursuant to rules and regulations of the department.

(b) *Mix designs not previously accepted.*

Each concrete producer or group of producers seeking approval of mix designs that have not been previously accepted by the Department shall file an application with the M.E.A. Division, Department of Buildings at the address provided in the City's website, <http://www.nyc.gov>. and shall furnish the following:

(1) A compilation of the proposed mix designs listing the batch weights, types of aggregates and other ingredients together with a numbering system that will provide identification of each mix for testing and recording purposes. Each compilation shall contain a title sheet upon which a master list of all the mixes shall be designated. Opposite each mix a space shall be provided for the signature of the examiner and the date of the approval of that particular mix.

When a mix has been approved for use as a "PREQUALIFIED MIX", the examiner shall affix his signature and the date in the space provided, and then he shall affix the approval stamp of the Commissioner of Buildings.

(2) For each mix utilizing a different combination of aggregates, admixtures, cement type, water-cement ratio, etc., a report of preliminary trials made by a testing laboratory licensed under §26-200 together with an attestation by the Architect or Engineer who supervised the making of the preliminary tests. The laboratory report shall include the following information:

(i) *Fine and coarse aggregate.*

Type (natural or manufactured sand, gravel, stone, etc.).

Weight per. cu. ft. dry rodded.

Specific gravity.

Percentage of voids.

Percentage of absorption.

Fineness modulus (see ASTM Definitions C125).

Gradation and comparison to ASTM C-33; also size of coarse aggregate.

(ii) Cement-type.

(iii) Batch weights.

(iv) Admixtures-type and amount.

(v) Test results of each particular mix design being submitted for approval. Separate tests shall be made for each compressive strength.

(vi) Attestation of the Architect or Engineer engaged by the producer or producers to supervise the tests.

(vii) Board of Standards and Appeals Cal. No. for items requiring Board approval, such as lightweight aggregate admixtures, etc.

(viii) Such other information required by §§27-605(a) (1), (2) and (3).

(3) Each concrete producer or group of producers that submits for approval the information required hereabove, shall be assigned an application number which is to be known as the "PREQUALIFIED MIX REFERENCE NUMBER". This REFERENCE NUMBER shall be valid only for the calendar year for which it is issued. All applications shall be submitted before November 1 of each year for review and for prequalification for the calendar year next following.

When the concrete proposed for use is to be produced using the mix designs from a summary compilation that has been approved, the architect or engineer who has been retained to make or supervise the Controlled Inspection shall verify that the mixes have been approved as

Rules and Regulations

"PREQUALIFIED MIXES" and shall file a statement for each project setting forth the PREQUALIFIED MIX REFERENCE NUMBER from which the concrete mix proportions are to be selected.

(c) *Mix designs previously approved and used.*

- (1) Each concrete producer making an application shall be assigned a PREQUALIFIED MIX REFERENCE NUMBER in the same manner as designated in Rule §5-03(b)(3).
- (2) The application shall set forth the details of location, date and laboratory that pertained to the previous project. It also shall include a statement setting forth the average strength obtained from tests made at the job, together with a summary of the total number of tests made and, of those tests, how many fell below the specified strength.
- (3) A copy of the laboratory report that was originally accepted shall be submitted. It shall contain the information listed under Rule §5-03(b)(2) (Reports with the water-cement ratios selected at a point on the curve established by preliminary mix tests corresponding to a strength of concrete 15% higher than the minimum ultimate strength called for on the plans shall not be accepted, unless the water-cement ratio complying with section §27-605(a)(2) can be determined).
- (4) The Architect or Engineer retained for the Controlled Inspection shall file a statement similar to the one mentioned in §5-03(b)(3).

§5-04 Approval of Concrete Production Facilities.

(a) The scope of these rules relating to facilities for the production of concrete under Article 5 of Subchapter 10 of Chapter 1 of Title 27 of the Administrative Code shall be applicable to batch plant installations of either a permanent or temporary nature, located on or off the site of construction.

(b) Application for approval of a batch plant shall be made on behalf of the owner by an engineer on department forms filed with the Commissioner of Buildings at the address provided in the City's website, <http://www.nyc.gov>. No off-site batch plants will be acceptable unless the legal use of the premises as a batch plant has been previously approved by either the Department of Buildings or the Department of Small Business Services.

(c) The concrete producer shall supply a list of all plant equipment to be used in the batching of concrete on forms furnished by the department.

(d) The concrete producer shall engage a Licensed Professional Engineer, not in his regular employ, to inspect the batching facilities. This inspection shall be made at the cost and expense of the concrete producer seeking plant approval. A copy of the verification of the inspection shall be submitted with the application for plant approval on forms furnished by the department.

(e) The applicant shall follow inspection procedures and complete the check list on forms furnished by the department which shall accompany the application for plant approval.

(f) The concrete producer shall promptly correct any objection made by the department which in its judgement it deems may adversely affect the quality of the concrete being placed. Should the department find any objection because of the producer's failure to meet the necessary standards for plant approval, corrections shall be made within 30 working days after the receipt, by the producer, of a written notice from the department.

(g) Approval of plant facilities shall be fully reviewed every two years upon a renewal submission for approval by the concrete producer provided the plant is not relocated during the two-year period.

(h) If a concrete plant is relocated from the location as filed on the original application form after initial approval is received, a new submission shall be required.

(i) During the two-year approval period, if any equipment is changed, added to, modified or moved within the same premises as originally filed, notification will be sent to the Commissioner of Buildings, Materials and Equipment Acceptance Division at the address provided in the City's website, <http://www.nyc.gov>.

Accompanying said notification shall be an amendment to the application verified by an affidavit from a professional engineer not in the regular employ of the concrete producer stating that the modification meets all requirements of the check list.

(j) The concrete producer shall be required to produce concrete in accordance with all applicable provisions of the Building Code and all pertinent reference standards referred to therein.

(k) The concrete producer shall be required to submit attestations and certifications specified in §§27-605 and 27-606 promptly for the appropriate type of concrete for each construction project. Where automated batching equipment is used, the tapes recording the batched weights shall be available for inspection for a period of two years.

(l) Concrete produced for the construction of buildings subject to controlled inspection of concrete shall not be batched and delivered to the construction site unless a person designated for batch plant inspection is present at the plant. However, it shall be permissible to deliver the concrete in the absence of the person designated for inspection when there are extenuating circumstances, provided the design architect or engineer and the architect or engineer designated for control inspections are notified promptly by phone with a `circumstances under which the uninspected concrete was shipped and shall supply all necessary facts such as the times and dates and volume of concrete batched and delivered, the design strength and mix proportions, and the application number, location, and contractor that the concrete is being delivered to. Similarly, the appropriate Borough Superintendent's office is to be promptly notified by phone with a follow-up letter together with copies of the other required notification letters.

(m) Approval shall be for a period of two years. However, temporary approval of batch plants may be authorized at the discretion of the Commissioner for a period of ninety days, provided an application for approval with necessary information furnished on appropriate forms is filed, and provided the application is otherwise acceptable in other respects. Temporary approvals may be renewed for additional ninety day periods, at the discretion of the Commissioner.

(n) Concrete producers shall be required to permit complete plant inspections by department personnel periodically.

(o) A copy of the batch plant approval will be forwarded to the owner of each facility and shall be posted in a conspicuous place at the plant.

(p) A violation of any of these rules or the falsifying or misrepresentation of any fact in the application or in any report shall constitute cause for revocation or suspension of any approval by the Commissioner, after a hearing upon prior notice of at least ten calendar days. For temporary approvals,

Rules and Regulations

the falsifying or misrepresentation of any fact in the application or in any report shall be cause for immediate revocation of such temporary approval by the Commissioner. However, notwithstanding the foregoing, when the public safety may be imminently jeopardized, or when a false report has been made, the Commissioner shall have the power, pending a hearing and determination of charges, to forthwith suspend any approval for a period not exceeding five calendar days.

CHAPTER 6 CRANES

§6-01 Erection and Dismantling of Climber/Tower Cranes.

An Erection and Dismantling Plan and Procedure for Climber/Tower Cranes, other than truck and crawler mounted tower cranes; shall be submitted to the Crane and Derrick Division of the Department of Buildings by a Licensed Professional Engineer or Registered Architect for the erection of any such Climber/Tower Cranes.

The procedure and plan submitted shall include the following:

(a) Identification of the equipment used; including all machines used in the erection or dismantling.

(b) A detailed identification of the assemblies and sub-assemblies for the erection and dismantling of the equipment.

(c) Location of the equipment, sidewalk sheds (or Department of Transportation street closing permits, if applicable), surrounding buildings, protection for their roofs and the pick-up points and loads and radius of swing of all loads. In addition, the safe load from the approved load radius chart shall be submitted for lift radius.

(d) A weight list of all assemblies and sub-assemblies that are to be lifted. Components are to be clearly marked with their weight painted on the assembly or stamped on metal tags attached to the assembly.

(e) The center of gravity of all unsymmetrical components shall be located and shown.

(f) The manufacturer of the Climber/Tower Crane shall certify as to the weight of assemblies and sub-assemblies. Alternately the Professional Engineer or Registered Architect applicant shall certify an erection or dismantling weight list with indication how such weights were determined.

(g) The approved Erection and Dismantling procedure and sequence with weights of assemblies and sub-assemblies, shall be given to the operator of the crane or derrick and to the rigger prior to commencement of the work.

(h) All accepted or approved installed safety devices on a crane involved in the erection or dismantling procedure shall be calibrated within the preceding three months. The certification of the calibration shall be submitted to the Crane and Derricks Division. The safety device

of the Climber/Tower Crane shall be checked as a part of the inspection procedure.

(i) A time schedule including date and time of day that the erection or dismantling is to take place. Erection or dismantling shall not be conducted prior to sunrise, or subsequent to sunset, and shall be limited by §24-224, of the Administrative (Air Pollution) Code.

(j) No Climber/Tower Crane shall be erected, operated, or disassembled in any roadway, sidewalk, or street unless a permit is first obtained from the Bureau of Highways of the NYCDOT.

(k) The Licensed Master Rigger or [sic] Licensed Climber/Tower Rigger, and the Site Safety Coordinators shall

be present at the job site during erection and dismantling. Their names as well as the company performing the work, shall be included in the data submitted.

(l) Cranes used to erect or dismantle Climber/Tower Cranes or Derricks located either within the lot line or on the street shall be indicated; and continue to be subject to the on-site inspection permit Buildings Notice procedures but such application shall be submitted to the Cranes and Derricks Division.

(m) A load radius chart approved by the Cranes and [sic] Derricks Division of the Buildings Department shall be posted in the cabin of crane.

CHAPTER 8 DEMOLITION

§8-01 Commencement of Demolition. (a) Definition.

(1) *Commencement of demolition.* Commencement of demolition shall mean the removal of partitions, ceilings, flooring, windows, piping and fixtures for plumbing and heating or any component parts of a vacant building or structure to be demolished. The removal of interior wood doors shall not be considered commencement of demolition.

(2) *Heavy duty and light duty sidewalk sheds.* A sidewalk shed is for heavy duty use or light duty use.

(i) A heavy duty sidewalk shed is designed to carry a live load of at least 300 pounds per square foot (psf). Live load, including storage of materials, shall not exceed 300 psf unless the sidewalk shed is designed to carry a live load greater than 300 psf, and an application for a permit thereof is filed by a licensed architect or engineer and approved by the Department.

(ii) A light duty sidewalk shed is designed to carry a live load of at least 150 pounds per square foot. Storage of materials of any kind is not permitted on light duty sheds.

(b) No demolition of a building or structure shall commence until a complete application has been filed and a permit has been obtained from the Department of Buildings.

(c) Prior to filing of an application for a demolition permit, the applicant must submit a pre-demolition report to the Department and obtain a pre-demolition inspection and sign-off by the Department.

(d) *Posting of signs.* (1) Prior to the filing of an application for a demolition permit, the demolition contractor shall post a sign in a readily visible location on the front of the building to be demolished or on the sidewalk shed or other protective structure listed in §26-252(a) of the Administrative Code of the City of New York adjacent to such building with the following information:

Demolition Contractor

Name of the Contractor

Business Address

Business Telephone No.

Department of Buildings Complaint Number

Date of Expiration of Sidewalk Shed Permit, if applicable

A space shall be reserved on the sign for the posting of the demolition permit

(2) Where a sidewalk shed is erected, the sign shall also state whether it is a heavy duty sidewalk shed or light duty

Rules and Regulations

sidewalk shed. If the shed is for light duty use, the sign shall include the statement that storage is not permitted on the shed.

(3) After a demolition permit is obtained, the sign shall also contain a copy of the approved demolition permit.

(4) The sign shall be posted prior to the commencement of demolition, shall measure 25 square feet and the lettering shall be block lettering with a minimum height of three inches. The sign shall be posted upon the wall or fence or shed and shall be of contrasting color from the background. No sign shall be required when the building to be demolished does not exceed 15 feet in height. The sign must be in place 24 hours prior to commencement of any demolition activity and remain visible at the site until all work is completed.

(5) Other than as set forth above and in 1 RCNY §27-03, there shall be no other information, pictorial representations, or any business or advertising messages posted on the sidewalk shed or bridge or other structure listed in §26-252(a) of the Administrative Code which is erected at the demolition site.

(e) Requirements for demolition permits.

(1) A complete application shall be filed with the Department, along with all the necessary reports and certifications.

(2) The building or structure, or affected part thereof, shall be vacant and unoccupied.

(3) All gas, electric, water, steam or other supply lines shall be disconnected and certifications by the respective utility companies or agency to that effect are to be filed pursuant to Administrative Code

§27-168. Where the use of electricity or water is required during demolition, such electric or water lines as are necessary may be maintained provided they are protected as required by the Departments of Building and Environmental Protection; provided further that the consent of the utility company is filed for the maintenance of the electric service and a certification is filed from the Bureau of Water Supply of the Department of Environment Protection that a permit for the use of water in the demolition has been issued.

(4) The building or structure shall be treated effectively for the extermination of rats and a certification shall be filed to that effect by a licensed exterminator or the Health Department.

(5) Where a sidewalk shed is required a permit for its erection shall be obtained and the sidewalk shed erected in accordance with Administrative Code §27-1021.

(6) Where renewal for an application for a sidewalk shed or other protective structure listed in §26-252(a) of the Administrative Code of the City of New York and pursuant to §27-1021 of the Administrative Code is required, such application must be signed by the owner of the affected property.

(7) A permit will not be issued if the applicant demolition contractor has outstanding violations of the Building Code on other demolition jobs where such applicant (i) has failed to respond to notices of violation of an administrative tribunal issued for such violations within the time required by law and has failed to cure such default and/or (ii) has failed to appear on the return date or dates or any subsequent return date or dates of any summonses issued in a criminal proceeding for such violations and has failed to remedy such non-appearance and/or (iii) has failed to comply with orders to correct such violations and/or (iv) has failed to certify such correction to the department within the time required by law and has failed to remedy such

non-compliance.

CHAPTER 9 RIGGING OPERATIONS

§9-01 Supervisory Responsibilities of a Licensed Master or Special Rigger. (a) *Applicability.* In accordance with section 26-172 of the Administrative Code, all rigging work, other than work exempted under section 26-173 of such code, must be performed by or under the supervision of a licensed special or master rigger. The rules in this section set forth the specific supervisory responsibilities of a licensed special or master rigger.

(b) *Definitions.*

Rigging Foreman. "Rigging Foreman" shall mean an individual, male or female, designated by a licensed master or special rigger in accordance with subdivision i of this section. Such person shall have the qualifications set forth in subdivision h of this section.

Critical Picks. "Critical Picks" shall mean rigging operations involving loads that:

(i) are at or above 95% of approved rated capacity of the crane or rigging equipment,

(ii) are asymmetrical or have a wind sail area exceeding 500 square feet,

(iii) may present a problem because of clearance, drift, or other interference,

(iv) are fragile or of thin shell construction and are not provided with standard rigging ears,

(v) require multiple cranes or derricks (tandem picks), or

(vi) require out of the ordinary rigging equipment, methods or setup.

(c) *Planning.* Except as otherwise specifically provided in subdivision (g)(2) of this section, the licensee must personally plan the equipment set-up and operation of all rigging operations. This responsibility may not be delegated.

(d) *Supervision of rigging operations other than critical picks.* Except as otherwise provided in subdivision e of this section, a licensee need not be personally on site during rigging operations provided that a rigging foreman designated by the licensee pursuant to subdivision i of this section is continuously on site and he or she performs and/or manages the work under the off site supervision of the licensee as follows:

(1) the licensee and the rigging foreman at the work site are in frequent and direct contact with each other

during the course of the rigging operation,

(2) for work involving the use of cranes, derricks, work platforms, suspension scaffolds or other rigging setup where the safe founding or support of such equipment is a cause of concern (i.e. over sidewalks, roadways or yards where vaults or other subsurface structures exist; or where hooks or clamps are used on parapet walls to support hanging scaffolds, etc.) the licensee personally visits the work site to inspect and approve the rigging equipment founding and setup prior to commencement of rigging operations and each time the founding or support changes,

(3) the licensee is readily available to provide on site supervision should the [*sic*] need arise, and

(4) the rigging foreman has in his or her possession at the work site the "Certificate of License Record" of the licensee (tear-off) issued by the Department, which shall be presented upon the demand of any enforcement officer.

Rules and Regulations

(e) *Supervision of critical picks.* The licensee must be continuously on site during critical picks and must personally perform or personally supervise all critical picks. Off site supervision of critical picks is not permitted.

(f) *Rigging Crew.* Except as otherwise provided in subdivision (g) of this section, all members of the rigging crew must be employees on the payroll of such licensee or where the license is used by the holder thereof for or on a behalf of a partnership, corporation or other business association as provided for in section 26-138(b) of the Administrative Code such members must be employees on the payroll of such partnership, corporation or business association.

(g) *Specially Crew.* Except as otherwise provided in this subdivision and except as provided for in section 26-138(b) of the Administration Code, the licensee and/or a rigging foreman designated by a licensee may not perform or supervise rigging work for another person, corporation, partnership or business association. Where rigging work is best handled by or requires crews of a specialty trade (e.g. handling hazardous materials or chemicals such as asbestos, or climbing, erecting or dismantling tower cranes) the licensee and/or a rigging foreman designated by such licensee may perform or supervise work on behalf of a person, partnership, corporation or business association engaged in such specialty trade, subject to the following conditions:

- (1) the Cranes and Derricks Division of the department must approve the licensee's written request for such proposed rigging operation,
- (2) the licensee must either plan the equipment setup and operation or be an active participant of the planning team,
- (3) for loads of one thousand two hundred pounds or more and for all critical picks, the licensee must provide continuous on site personal supervision to the rigging crew,
- (4) for loads below one thousand two hundred pounds which are not critical picks, the licensee need not be on site if a rigging foreman designated by such licensee is continuously on site.[sic] He or she manages the work under the off site supervision of the licensee in accordance with the conditions set forth in items (1), (2), (3), and (4) of subdivision (d) of this section,
- (5) the licensee and/or his or her designated rigging foreman must have full authority to examine rigging hardware, to approve rigging setups, to mandate changes and to stop the job,
- (6) the licensee is responsible for all aspects of rigging safety on the job, and
- (7) the licensee shall confirm that members of the specialty crew are insured to the minimum requirements specified in section 26-178 of the code and are covered by worker's compensation by the specialty crew's employer.

(h) *Qualifications for designation as a rigging foreman.*

- (1) An individual designated as a rigging foreman by a licensed special or master rigger shall:
 - (i) be an employee on the payroll and covered by the worker's compensation insurance of the licensee or the business association of the licensee,
 - (ii) be at least 18 years of age,
 - (iii) be able to read and write English,
 - (iii) be able to identify critical picks,
 - (iv) be familiar with the relevant sections of the Building Code, OSHA safety standards and industry safety practices,
 - (v) have been trained to react properly to mechanical

malfunctions or adverse weather, and

(vi) be able to evaluate the fitness of the rigging crew, including, where applicable, the issuance of a certificate of fitness pursuant to section 9-03 of this chapter.

(2) An individual designated as a rigging foreman by a licensed special rigger shall, in addition to the qualifications set forth in paragraph one of this subdivision, have the following additional qualifications:

(i) have at least 1 year's practical experience in the hoisting and rigging business, and

(ii) be able to explain the risks incident to such business and precautions to be taken in connection therewith.

(3) an individual designated as a rigging foreman by a licensed master rigger shall, in addition to the qualifications set forth in paragraph one of this subdivision, have the following additional qualifications:

(i) have at least 5 years practical experience in the hoisting and rigging business, and

(ii) be knowledgeable about and be able to explain the risks incident to the following, where applicable to the particular job:

(A) rigging operations and precautions to be taken in connection therewith,

(B) safe loads and computation thereof,

(C) types and methods of rigging, and

(D) pertinent hardware such as ropes, cables, blocks, poles, derricks, sheerlegs and other tools used in connection with rigging operations.

(i) *Designation of a Rigging Foreman.* Designation shall consist of the filing of written notification with the Department's Licensing Division of the following information:

(1) A list of all rigging foreman employed by the licensee or the business association of the licensee. Each rigging foreman's full name, home address, and home phone number shall be included on the list.

(2) The notification shall be signed by the licensee, shall contain his or her license number and shall be on the business letterhead of the licensee or of the business association of the licensee. The notification shall contain a representation by the licensee that all of the rigging foreman designated by him or her have the qualifications specified in subdivision h of this section.

(3) The list must be updated within two weeks of any change in the reported information relating to designated individuals or within two weeks of the termination of a designation by the filing of a new notification listing all rigging foreman designated by the licensee. The new notification shall contain the information set forth in items (1) and (2) above. The new list will supersede any earlier filed notification.

(j) *Photo Identification Card.* The licensee shall issue a photo identification card (see Exhibit 1) to each rigging foreman designated by him or her with the licensee's signature affixed thereto. Such card shall be carried by the rigging foreman at all times while he or she is engaged in any of the duties requiring such designation and shall be presented upon the demand of any authorized enforcement officer. It shall be the responsibility of the licensee to retrieve the identification card when such designation is terminated. A designation shall be terminated by the licensee if (1) the person leaves the employ of the licensee or business association of the licensee, (2) the licensee finds that the designee is not competently performing his

Rules and Regulations

or her duties or, (3) the licensee finds that the designee has acted in an unsafe or irresponsible manner in performing his or her duties.

(k) *Responsibility.* The designation of one or more rigging foreman shall not affect the licensee's and/or business association's responsibility or liability for all aspects of rigging safety including but not limited to the actions of rigging foreman, rigging crews and specialty crews, if any.

(l) *Failure to comply with rules.* If these rules are not complied with the Department may order that rigging operations stop, commence disciplinary action against the licensee and/or commence proceedings for the impositions of fines or civil penalties.

§9-02 Supervisory Responsibilities of a Licensed Master or Special Sign Hanger.

(a) *Applicability.* In accordance with section 26-182 of the Administrative Code, all sign hanging work, other than work exempted under section 26-184 of such code, must be performed by or under the supervision of a licensed sign hanger. The rules in this section set forth the specific supervisory responsibilities of a licensed special or master sign hanger.

(b) *Definitions.*

Sign Hanging Foreman. "Sign Hanging Foreman" shall mean an individual, male or female, designated by a licensed master or special sign hanger in accordance with subdivision h of this section. Such person shall have the qualifications set forth in subdivision g of this section.

Critical Picks. "Critical Picks" shall mean sign hanging operations involving loads that:

- (i) are at or above 95% of approved rated capacity of the crane or rigging equipment,
- (ii) are asymmetrical or have a wind sail area exceeding 1500 square feet,
- (iii) may present a problem because of clearance, drift, or other interference,
- (iv) are fragile or of thin shell construction and are not provided with standard rigging ears,
- (v) require multiple cranes or derricks (tandem picks), or
- (vi) require out of the ordinary rigging equipment, methods or setup.

(c) *Planning.* The licensee must personally plan the equipment set-up and operation of all sign hanging operations. This responsibility may not be delegated.

(d) *Supervision of sign hanging operations other than critical picks.* Except as otherwise provided in subdivision e of this section, a licensee need not be personally on site during sign hanging operations provided that a sign hanging foreman designated by the licensee pursuant to subdivision h of this section is continuously on site and he or she performs and/or manages the work under the off-site supervision of the licensee as follows:

- (1) the licensee and the sign hanging foreman at the work site are in frequent and direct contact with each other during the course of the sign hanging operation,
- (2) for work involving the use of cranes, derricks, work platforms, suspension scaffolds or other rigging setup where the safe founding or support of such equipment is a cause of concern (i.e. over sidewalks, roadways or yards where vaults or other

subsurface structures exist; or where hooks or clamps are used on parapet walls to support hanging scaffolds, etc.) the licensee personally visits the work site to inspect and approve the rigging equipment founding and setup prior to commencement of rigging operations and each time the founding or support changes, and

(3) the licensee is readily available to provide on site supervision should the need arise, and

(4) The sign hanging foreman has in his or her possession at the work site the "Certificate of License Record" of the licensee (tear off) issued by the Department, which shall be presented upon the demand of any authorized enforcement officer.

(e) *Supervision of critical picks.* The licensee must be continuously on site during critical picks and must personally perform or personally supervise all critical picks. Off site supervision of critical picks is not permitted.

(f) *Sign Hanging Crew.* All members of the sign hanging crew must be employees on the payroll of such licensee or, where the license is used by the holder thereof for or on behalf of a partnership, corporation or other business association as provided for in section 26-138(b) of the Administration Code, such members must be employees on the payroll of such partnership, corporation or business association. Except as provided for in section 26-138(b) of the Administrative Code, the licensee and/or a sign hanging foreman designated by a licensee may not perform or supervise sign hanging work for another person, corporation, partnership or business association.

(g) *Qualifications for designation as a sign hanging foreman.*

(1) An individual designated as a sign hanging foreman by a licensed special or master sign hanger shall:

(i) be an employee on the payroll of and covered by the worker compensation insurance of the licensee or the business association of the licensee,

(ii) be at least 18 years of age,

(iii) be able to read and write English,

(iv) be able to identify critical picks,

(v) be familiar with the relevant sections of the Building Code, OSHA safety standards and industry safety practices,

(vi) have been trained to react properly to mechanical malfunctions or adverse weather,

(i) be able to evaluate the fitness of the sign hanging crew, including where applicable, the issuance of a certificate of fitness pursuant section 9-03 of this chapter,

(viii) be able to read plans and specifications relating to sign construction and erection, including supporting framework and other supports,

(xi) have a knowledge of the problems and practices of sign construction and hanging, and

(xii) be familiar with the equipment and tools used in sign installations.

(2) An individual designated as a sign hanging foreman by a licensed special sign hanger shall, in addition to the qualifications set forth in paragraph one of this subdivision, have at least 3 years practical experience in sign hanging work,

(3) An individual designated as a sign hanging foreman by a licensed master sign hanger shall, in addition to the qualifications set forth paragraph one of this subdivision, have at least 5 years practical experience in sign hanging work,

(h) *Designation of a Sign Hanging Foreman.* Designation

Rules and Regulations

shall consist of the filing of written notification with the Department's Licensing Division of the following information:

(1) A list of all sign hanging foreman employed by the licensee or by the business association of the licensee. Each sign hanging foreman's full name, home address, and home phone number shall be included on the list.

(2) The notification shall be signed by the licensee, shall contain his or her license number and shall be on the business letterhead of the licensee or of the business association of the licensee. The notification shall contain a representation by the licensee that all of the sign hanging foreman designated by him or her have the qualifications specified in subdivision g of this section.

(3) The list must be updated within two weeks of any change in the reported information relating to designated individuals or within two weeks of the termination of a designation by the filing of a new notification listing all sign hanging foremen designated by such licensee. The new notification shall be filed in the manner and shall contain the information set forth in items (1) and (2) above. The new list will supersede any earlier filed notification.

(i) *Photo Identification Card.* The licensee shall issue a photo identification card (see Exhibit 1) to each individual designated by him or her as a sign hanging foremen with the licensee's signature affixed thereto. Such card shall be carried by the sign hanging foremen at all times while he or she is engaged in any of the duties requiring such designation and shall be presented upon the demand of any authorized enforcement officer of the city. It shall be the responsibility of the licensee to retrieve the identification card when such designation is terminated. A designation shall be terminated by the licensee if (1) the person leaves the employ of the licensee or business association of the licensee, (2) the licensee finds that the designee is not competently performing his or her duties or, (3) the licensee finds that the designee has acted in an unsafe or irresponsible manner in performing his or her duties.

(j) *Responsibility.* The designation of one or more sign hanging foremen shall not affect the licensee's and/or business association's responsibility or liability for all aspects [sic] of sign hanging safety including but not limited to the actions of sign hanging foremen and sign hanging crews.

(k) *Failure to comply with rules.* If these rules are not complied with the Department may order that sign hanging operations stop, commence disciplinary action against the licensee and/or commence proceedings for the imposition of fines or civil penalties.

§9-03 Minimum Requirements for Individuals Working on Suspension Scaffolds

(a) *Applicability.* In accordance with section 26-172 and 26-182 of the Administrative Code and Subchapter 19 of Chapter 1 of Title 27, "Safety of Public and Property During Construction Operations," the rules in this section establish minimum requirements for all individuals working on or operating suspension scaffolds, either performing construction or alteration work pursuant to a permit issued by the Department, or performing rigging or sign hanging work under the supervision of a licensed master or special rigger or a master or special sign

hanger.

(b) *Minimum Requirements.* Only the following individuals may work on or operate a suspension scaffold:

(1) Where work is performed either by or under the supervision of a licensed rigger or sign hanger, the following persons may work on or operate a suspension scaffold:

(i) a licensed master or special rigger,

(ii) a licensed master or special sign hanger,

(iii) a rigging or sign hanging foremen as described in §9-01 and §9-02, or

(iv) a rigging or sign hanging crew member issued a certificate of fitness by the licensed rigger or sign hanger or his or her designate rigging or sign hanging foreman.

(2) (i) Where construction or alteration work is performed pursuant to a permit issued by the Department and, in accordance with §26-173 and §26-184 of the Administrative Code, such work is not performed by or under the supervision of a licensed rigger or sign hanger, the following persons may work on or operate a suspension scaffold:

(A) a person who holds a certificate of completion from a recognized scaffold safety training course as set forth in subdivision (d)(1) and (d)(3) of this section, or

(B) an apprentice in a recognized program, as set forth in subdivision (d)(2) of this section, or

(C) a person who holds a challenge examination certificate

(D) from a recognized administrator of challenge examinations, as set forth in subdivision (d)(4) of this section.

(ii) In accordance with §27-1045, it shall be the responsibility of the superintendent of construction to ensure that any person working on or operating a suspension scaffold on or the job site has the necessary certificate of completion or challenge examination certificate or is enrolled in a recognized apprenticeship program. The superintendent of construction must maintain written records to such effect.

(3) In addition to those persons listed in (b)(1) and (b)(2) above, a registered architect or professional engineer who is familiar with rigging hardware, rigging equipment setup and operation, pertinent Building Code provisions, Federal OSHA and State safety standards, emergency procedures, and recommended industry safe work practices may work on or operate a suspension scaffold, provided, however, that a registered architect or professional engineer not familiar with such codes, standards, procedures and practices may ride on a scaffold to perform inspections as long as the architect or engineer does not perform work from or operate the scaffold.

(b) *Certificate of Fitness.*

(1) *Minimum Requirements.* A person issued a certificate of fitness must:

(i) be found capable of performing the scaffold work in a safe and responsible manner by the issuer at the time of issuance, and

(ii) be able to communicate without difficulty with the supervising licensed rigger, licensed sign hanger, rigging or sign hanging foreman, or superintendent of construction on site, and either

(iii) possess a certificate of completion from a recognized scaffold safety training course in accordance with subdivision (d)(1) and (d)(3) of this section, or

(iv) be enrolled in a recognized scaffold apprenticeship program

Rules and Regulations

in accordance with subdivision (d)(2) of this section, or

(v) possess a challenge examination certificate in accordance with subdivision (d)(4) of this section.

(2) *Persons Authorized to Issue a Certification of Fitness.* The following persons may issue a certificate of fitness:

- (i) a licensed master or special rigger,
- (ii) a licensed master or special sign hanger, or
- (iii) a rigging or sign hanging foreman designated pursuant to sections 9-01 or 9-02 of these rules, as agent of the licensee.

(3) *Duty of Licensee to Ensure Compliance.* It shall be the sole responsibility of the licensee who issues the certificate of fitness, either personally or through a designated foreman, to ensure that the individual who receives the certificate meets the requirements of subdivision (c)(1) of this section for the particular job. It shall be the licensee's responsibility to maintain written records and copies relating to whom and when certificates were issued, as well as each certificate holder's certificate of completion from a recognized scaffold safety training course or apprentice program or challenge examination certificate, which substantiates the individual's fitness. If a person issued a certificate of fitness is later found to be unqualified or to have failed to work on a suspension scaffold in a safe and workmanlike manner, it shall be the licensee's responsibility to rescind the certificate of fitness and to remove the subject person from the job.

(4) *The Certificate of Fitness.* The certificate of fitness must include the name of the holder, the date of the issuance, the name, and license number of the licensee, the name, address, and telephone number of the company, and the signature of the issuer.

(i) Job-specific certificate of fitness for crew members employed only for a particular job or jobs. The certificate of fitness must contain the job location for which such certificate is valid as well as the duration of the job (see exhibit 2). Such certificate of fitness, as well as a photo identification of the certificate holder acceptable to the Department, must be available on site for inspection.

(ii) Certificate of fitness for regular members of the licensee's rigging or sign hanging crew. Notwithstanding the provisions of subdivision (c)(4)(i) of this section, at the option of the issuer, a permanent non job-specific photo identification or certificate of fitness may be issued to regular members of the licensee's business association's rigging or sign hanging crews.

(d) *Recognized Scaffold Safety Training Courses and Apprenticeship Programs.* (1) *Recognized Scaffold Safety Training Course.* Any organization (e.g. private, governmental, non-profit, or trade union) or institute may apply to the Department for recognition of its scaffold safety training course. Such application shall be made to the Department's Cranes and Derricks Division and shall include: instructors' qualifications, curriculum, teaching schedule, and materials used. The training course must include a significant field component, including instruction in rigging hardware (e.g. ropes, blocks, motors, scaffolds, controls, etc.), methods (e.g. reeving, suspension, startup procedures, netting, etc.), and applicable laws (NYC Building Codes and Rules, OSHA standards, etc.) The Department may participate in or observe any training course without prior notification, and reserves the right to rescind recognition. The Department shall inform or approve a recognized course in writing, and

shall maintain a list of approved training courses. Any organization or institute that offers the recognized scaffold safety training course must also offer a challenge examination outlined in subdivision(d)(4) of this section, either free or at a nominal cost to all applicants.

(2) *Recognized Apprenticeship Program.* Any organization (e.g. private, governmental, non-profit, trade union) may apply to the Department for recognition of its scaffold safety training apprenticeship program. The requirements for recognition are the same as for a recognized scaffold safety training course as set forth in subdivision (d)(1) of this section. (3) *Certificate of Completion.* The organization providing a recognized scaffold safety training course or apprenticeship program may issue identification cards or certificates of completion to individuals who successfully complete the recognized course or program. The certificate of completion issued must include the name and address of the issuing organization, the date of issuance, and the name of the recipient, and must state "NYC DOB Recognized Scaffold Safety Training Course" or "Apprenticeship Program." Such certificate must be signed by the course administrator.

(4) *Challenge Examination and Challenge Examination Certificate.* The challenge examination shall be administered by organizations or institutes that conduct a recognized scaffold safety training course or recognized apprenticeship program. The challenge examination shall consist of written and hands-on tests that enable successful candidates to demonstrate a minimum level of knowledge and skills equivalent to graduates of a recognized scaffold safety training course or apprenticeship program. A person passing the challenge examination shall be issued a challenge examination certificate by the course or examination administrator. This challenge examination certificate shall be the equivalent to the certificate of completion and shall consist of similar data, format and signature as set forth in subdivision (d)(3) of this section. Written and hands-on tests for the challenge examination shall be submitted to and pre-approved in writing by the Department of Buildings, Cranes and Derricks Division. The Cranes and Derricks Division reserves the right to monitor the test to ensure its quality and fairness, and to revoke any approval if guidelines are not adhered to. Organizations or institutes that offer recognized scaffold safety training or apprenticeship programs in English or in any other language must offer an equivalent challenge examination in the appropriate language to any applicant regardless of his or her gender, race, national origin, organization or union membership, religion or creed.

(e) *Compliance.* Failure to comply with the above rules, including but not limited to any person working on a suspension scaffold unable to produce either a valid certificate of fitness or, where applicable, a certificate of completion or a challenge examination certificate and a photo identification card, may result in the Department's ordering all work stopped, issuing violations, and commencing disciplinary action against the licensee, and/or commencing proceedings for the imposition of fines or civil penalties.

(f) *Effective date.* The provisions of this section 9-03 shall take effect on and after May 1, 2001.

Rules and Regulations

§9-04 Revocation, Suspension or Refusal to Renew License of Special or Master Rigger or Special or Master Sign Hanger.

(a) The license of a special or master rigger or of a special or master sign hanger may be suspended, revoked or not renewed and/or a fine of not more than five thousand dollars may be imposed for each instance of the following:

- (1) Fraud, deceit, collusion or misrepresentation by the licensee in obtaining or renewing such license.
 - (2) Poor moral character that adversely impacts upon the licensee's fitness to perform his or her duties and responsibilities as a licensee.
 - (3) Negligence, incompetence, lack of knowledge of the Building Code and applicable rules of the Department or disregard of the Building Code and applicable rules of the Department as demonstrated in the performance of the duties and responsibilities of a licensee.
 - (4) Failure to comply with an order of the Commissioner or his or her designee in connection with the business or duties and responsibilities of the licensee.
 - (5) Making a false or misleading statement to the Department or other government agency on any form or report filed with the Department or records required to be kept by the department in relation to the business or duties and responsibilities of the licensee.
 - (6) Failure to file a form, report or statement or to keep records required by the Department or other government agency in connection with the business or duties and responsibilities of the licensee.
 - (7) Failure to comply with any of the provisions of sections 9-01, 9-02 or 9-03 of this chapter.
 - (8) Impeding or obstructing an investigation of the Commissioner or his or her designee relating to the business or duties and responsibilities of the licensee.
 - (9) Conviction of a criminal offense where the underlying act arises out of the business or duties and responsibilities of the licensee.
 - (10) The making, completing or altering of a written instrument of the type issued by the Department with respect to the business or duties and responsibilities of the licensee with the intent to defraud or deceive another person.
 - (11) Violation of or failure to comply with the provisions of the Building Code and other applicable laws and rules relating to the business or duties and responsibilities of the licensee.
 - (12) Failure to pay a fine or penalty imposed by the Department under this section or in any civil or criminal proceeding in a court or in a proceeding before the environmental control board arising out of the business or duties and responsibilities of the licensee.
 - (13) Failing to safeguard the public or property during the performance of the business or duties and responsibilities of the licensee in accordance with applicable safety standards.
- (b) Except as otherwise provided in subdivision (c) of this section, no license shall be suspended or revoked or fine imposed unless prior thereto the licensee has been afforded the opportunity for a hearing on the charges before the Office of Administrative Trials and Hearings (OATH). The hearing shall be governed by the rules of procedure of OATH. A proceeding shall be commenced by the service of charges by the Department's IAD Unit by mail on the licensee.

The Administrative Law Judge at OATH shall issue recommended findings of fact and a recommended decision and shall forward such findings and recommended decision and the record of the proceedings to the Commissioner who shall make a final determination on the charges and penalty as per this section.

(c) Notwithstanding any inconsistent provision of subdivision b of this section, where the Commissioner finds that the public safety may be imminently jeopardized or that there is reasonable cause to believe that the continued use of a special or master rigger or special or master sign hanger license will create a condition of imminent peril to public safety, he or she may forthwith suspend any license pending a hearing, to be held as soon as practicable in light of the circumstances before OATH, and, determination of charges.

CHAPTER 10 DRUMS FOR DERRICK LOAD AND BOOM HOISTS

§10-01 Requirements.

Drums for derrick load and boom hoists shall be contained on the same bed frame *[sic]* operated independently by one or more engines.

Each drum shall have a separate hand brake and clutch or power down mechanism in lieu of a clutch, as well as a positive dog on the drum and a dog on the brake pedal.

The hoisting mechanism shall be in full view and under the control of a licensed hoisting machine operator at all times.

CHAPTER 11 ELEVATORS, ESCALATORS, PERSONNEL HOISTS AND MOVING WALKS

§11-01 Rules for the Certification and Qualification of Private Elevator Inspection Agencies and for the Performance of Inspections and Filing of Inspection Reports for Elevators and Escalators by such Agencies.

(a) *Certificates of approval for agency directors.* (1) A Certificate of Approval for an agency director shall be the written authorization of the commissioner to an individual who shall be the responsible representative of an entity, who carries on her, his or its business as an independent contractor that witnesses tests and inspects elevators, escalators and related equipment. Each private elevator inspection agency shall have one or more directors who supervise the operations of the agency and hold a certificate of approval from the Department of Buildings.

(2) In order to be granted an agency director's certificate of approval, an applicant must:

(i) have a minimum of ten (10) years of experience within the last fifteen (15) years immediately preceding the date of the application for a Certificate of Approval, or a minimum of five (5) years experience within the last seven (7) years immediately preceding the date of the application for a Certificate of Approval if applicant is a New York State licensed Professional Engineer or Registered Architect, in the supervision of the assembly, installation, maintenance, repair, design or inspection of elevators; and

(ii) demonstrate to the commissioner's satisfaction, including performance on any written or oral tests the Commissioner may require, that the applicant is sufficiently familiar with the

Rules and Regulations

construction and maintenance of elevators, escalators and related equipment within the provisions of Subchapter 18 of Chapter 1 of Title 27 of the Administrative Code and Reference Standard 18; and

(iii) demonstrate to the commissioner's satisfaction that the applicant is of good moral character so as not to adversely impact upon his or her fitness to conduct a private elevator inspection agency; and

(iv) furnish payment to the Department for the actual cost of conducting a background investigation of the applicant.

(3) The applicant must complete such questionnaires and provide such supporting data as the commissioner may require including but not limited to a Private Elevator Inspection Qualification/Background form ("qualification/background form") provided by the Department of Buildings which describes, among other things, the applicant's required experience history as follows: job title or capacity of employment; license, if any; name and address of each employer; length of service for each employer; and any criminal convictions. The applicant shall then submit the completed qualification/ background form to the Licensing Division.

(4) Prior to the department's issuance of a certificate of approval for the agency director, the applicant shall submit the following to the Licensing Division;

(i) the completed qualification/background form and supporting data as the commissioner may require;

(ii) the filing fee specified in §26-213(c)(a) of the Administrative Code and the actual cost of conducting a background investigation of the applicant;

(iii) a copy of the inspection agency's general liability insurance policy for the amount of one million dollars (\$1,000,000), with coverage provided for the term of the certificate of approval naming the New York City Department of Buildings, Licensing Division as an additional insured on said insurance certificate;

(iv) documentation indicating compliance with the provisions of the New York State Worker's Compensation Law; and

(i) a current business address, which the applicant is responsible for keeping updated.

(5) After the applicant has complied with paragraphs 1 through 4 above, the department shall issue to the applicant an agency Director's Certificate of Approval. The preceding provisions notwithstanding, the commissioner may refuse to issue such a Certificate of Approval for any of the reasons specified as a grounds for revocation or suspension set forth in subsection

(e) below. Each agency director shall supervise the operations of only one private elevator inspection agency.

(b) *Certificates of approval for agency inspectors.* (1) A Certificate of Approval for an inspector shall be the written authorization of the commissioner to an individual to conduct periodic inspections of elevators, escalators and related equipment and who shall be employed and supervised by a director who holds a Certificate of Approval from the Department of Buildings or who shall be employed by a person or entity who carries on her, his or its business as an independent contractor to witness tests and inspect elevators, escalators and related equipment. Every inspector employed by a private elevator inspection agency shall hold a certificate of approval from the Department of Buildings.

(2) In order to be granted an inspectors' certificate of approval,

an applicant must:

(i) have a minimum of five (5) years of satisfactory experience, within the last seven (7) years immediately preceding the date of application to a certificate of approval, in the assembly, installation, repair, design, or inspection of elevators, or as an elevator mechanic;

(ii) demonstrate to the commissioner's satisfaction, including performance on any written or oral tests the Commissioner may require, that the applicant is sufficiently familiar with the construction and maintenance of elevators, escalators and related equipment within the provisions of Subchapter 18 of Chapter 1 of Title 27 of the Administrative Code and Reference Standard 18; and

(iii) demonstrate to the commissioner's satisfaction that the applicant is of good moral character so as not to adversely impact upon his or her fitness to conduct elevator inspection; and

(iv) complete a questionnaire and provide supporting data as the commissioner may require; and

(v) furnish payment to the Department for the actual cost of conducting a background investigation of the applicant.

(3) The applicant must complete such questionnaires and provide such supporting data as the commissioner may require including but not limited to a Private Elevator Inspection

Qualification/Background form ("qualification/background form") provided by the Department of Buildings which describes the applicant's required experience history as follows: job title or capacity of employment; license, if any; name and address of each employer; length of service for each employer; and any criminal convictions. The applicant shall then submit the completed qualification/ background form to the Licensing Division.

(4) Prior to the department's issuance of a certificate of approval for an agency inspector, the applicant shall submit the following to the Licensing Division:

(i) the completed qualification/background form and supporting data as the commissioner may require;

(ii) the filing fee specified in §26-213(c)(a) of the Administrative Code and the actual cost of conducting a background investigation of the applicant;

(iii) a current business address, which the applicant is responsible for keeping updated.

(5) After the applicant has complied with paragraphs 1 through 4 above, the department shall issue to the applicant an agency inspector's certificate of approval. The preceding provisions notwithstanding, the commissioner may refuse to issue such a Certificate of Approval for any of the reasons specified as a grounds for revocation or suspension set forth in subsection (e) below. Private elevator inspectors who are employed by more than one private elevator inspection agency must have a certificate of approval for each agency by which they are employed. In such cases, an inspector shall submit a separate qualification/background form and pay a separate filing fee for each agency by which he or she is employed.

(c) *Department listings of private inspection agencies.* (1) Each private inspection agency shall furnish the Department of Buildings, Licensing Division with a list of directors and inspectors, its certificate of approval numbers, a complete table of organization(s), including identification of persons or titles, and a current business address. This information shall

Rules and Regulations

be set forth on letterhead bearing the name and address of the private elevator inspection agency.

(2) Notification of any changes in the information required to be furnished to the Department by subsection (c)(1) shall be sent to the Licensing Division by certified mail within five (5) days of the change.

(3) All private inspection agencies must have a legal place of business within the City of New York. A post office box in New York City is not acceptable.

(c) *Renewal of Certificates.* (1) Every certificate of approval provided for in this section shall be renewed in person within thirty (30) days prior to its December 31 expiration date.

(2) Prior to the renewal of a certificate of approval for an agency director, the director shall submit the following to the Department of Buildings Licensing Division:

(i) the renewal fee specified in §26-213(c)(a) of the Administrative Code; and

(ii) a copy of the inspection agency's general liability insurance policy for the amount of one million dollars (\$1,000,000), with coverage provided for the renewal term of the director's certificate of approval, naming the New York City Department of Buildings, Licensing Division as an additional insured on said insurance certificate; and

(iii) documentation indicating compliance with the provisions of the New York State Worker's Compensation Law; and

(iv) documentation demonstrating to the commissioner's satisfaction that the applicant continues to be of good moral character so as not to adversely impact upon his or her fitness to conduct a private elevator inspection agency.

(3) Prior to the renewal of a certificate of approval for an agency inspector, the inspector shall submit to the Department of Buildings, Licensing Division:

(i) the renewal fee specified in §26-213(c)(a) of the Administrative Code; and

(ii) documentation demonstrating to the commissioner's satisfaction that the applicant continues to be of good moral character so as not to adversely impact upon his or her fitness to conduct elevator inspections.

(4) After the director or inspector has complied with the requirements stated above, the department shall issue a renewal of the director's or inspector's certificate of approval. The preceding provisions notwithstanding, the commissioner may refuse to issue a renewal of a director's or inspector's Certificate of Approval for any of the reasons specified as a grounds for revocation or suspension set forth in subsection (e) below.

(5) Agency directors and inspectors not renewing their certificates of approval by December first of each year shall be subject to the late fee specified §26-213(c)(b) of the Administrative Code. Those agency directors and inspectors not renewing their certificates of approval by January 1 shall be suspended until the applicable late fees are paid. In the event a director or inspector's certificate of approval has lapsed for a period of five (5) years or more, the director or inspector must submit to the Department and follow the procedures for a new application.

(e) *Suspension or revocation of agency directors' or inspectors' certificates.*

(1) The commissioner or his or her designee may suspend or revoke an Agency Director's or Inspector's Certificate of

Approval or impose a fine not to exceed five thousand dollars upon a finding of any of the following:

(i) fraud or deceit in obtaining a Certificate of Approval or renewal thereof;

(ii) the making of a false or misleading statement on any form or report filed with the Department or failure to file a statement, report or form required by the law of [sic] the Department;

(iii) the willful impeding or obstruction of the filing of a statement, report or form of another;

(iv) fraudulent dealings;

(v) negligence, incompetence, lack of knowledge of the Building Code, or disregard for the Building Code, as demonstrated in the performance of elevator inspections or the submission of any form or report filed with the Department;

(vi) exhibiting a practice of failing to timely or properly carry out the inspection of elevators;

(vii) engaging or assisting in any act that endangers the public safety and welfare;

(viii) failure to comply with or abide by an order of the commissioner;

(ix) in the case of an agency Director, delegating inspectorial duties to a person who the agency director knows or has reason to know is not qualified to inspect elevators;

(x) poor moral character that adversely impacts upon the individual's fitness to conduct a private elevator inspection agency or elevator inspections;

(xi) the conviction for a criminal offense where the underlying act arises out of that individual's professional dealings with the City of New York or with any other governmental entity;

(xii) engaging in any other conduct evidencing a willful or negligent failure to comply with provisions of federal, state or local law, or rules or regulations promulgated pursuant to statutory authority;

one or more violations of any provisions of Title 26, Chapter One of [sic] Title 27, Chapter One of the Administrative Code or rules adopted pursuant to such provisions related to elevator inspections.

(2) Where the commissioner or his or her designee, in his or her discretion, deems that there is probable cause to believe that the Certificate of Approval of the agency director and/or inspector should be suspended or revoked or that the director and/or inspector should be fined, unless otherwise provided, charges shall be preferred by the Department's IAD Unit and served by mail upon the appropriate party. The director and/or inspector shall be entitled to a hearing before the Office of Administrative Trials and Hearings, to be held in accordance with the provisions of Title 48 of the Rules of the City of New York, as provided by rules promulgated by the Department.

(3) Where the commissioner or his or her designee, in his or her discretion, deems that there is probable cause to believe that the continued Certificate of Approval of the agency director and/or inspector will create a condition of imminent peril to public safety, the suspension or revocation shall be effective immediately pending a hearing to be held as soon as practicable in light of the circumstances before the Office of Administrative Trials and Hearings.

(f) *Performance of inspections and filings of inspection reports* (1) In compliance with Section 27-1000 of the

Rules and Regulations

Administrative Code, the mandated periodic inspection of every new and existing elevator, escalator and related equipment listed in the Building Code shall be performed by an inspector who holds a Certificate of Approval from the Department and who is supervised by a director who holds a Certificate of Approval from the Department.

(2) The mandated periodic inspection must be performed between January 1 and September 15 of each year.

(3) Each inspection or witnessed test of an elevator or escalator performed by an inspection agency shall be recorded on forms prescribed by the commissioner. Each such form shall confirm that the elevator, escalator and/or related equipment was inspected or the test was witnessed by the holder of a Certificate of Approval and shall be signed by the inspector who performed the inspection or witnessed the test, the agency director and building owner. Agency directors shall include their Certificate number on the form. The forms are to be completed legibly at the time of inspection. The completed and signed forms shall be forwarded to the building owner within five (5) calendar days after the inspection and to the Department's Elevator Division within fourteen (14) calendar days after the inspection.

(4) After each inspection or test, the inspector shall affix the inspection date and his/her signature over a stamp identifying his/her private inspection agency and his/her Certificate of Approval number on the elevator car or escalator inspection certificate.

(5) During inspection and after testing, all parts of the equipment shall be inspected to determine that they are in safe operating condition and that parts subject to wear have not worn to such an extent as to affect the safe operation of the installation.

(6) If an inspection reveals that any elevator or escalator is unsafe or hazardous to life and safety, the device is to be taken out of service immediately by the inspection agency. The building owner shall be notified immediately. In addition, a copy of such notification shall be sent by certified mail to the Department of Buildings, Elevator Division within 24 hours.

§11-02 Elevator and Escalator Violations Constituting a Condition Dangerous to Human Life and Safety.

(a) *Dangerous conditions.* Any of the following elevator and escalator violations constitute a condition dangerous to human life and safety.

(1) Elevator out-of-service when there is only one elevator in the building or building section.

(2) Fireman service not functioning in premises.

(3) Badly worn, defective, or damaged hoist cables and/or governors cables.

(4) Defective hoistway doors.

(5) Defective hoistway door interlocks.

(6) Defective car door/gate.

(7) Defective car door/gate switch.

(8) Defective/missing vision panels.

(9) Defective car safety devices.

(10) Defective brake assembly.

(11) Defective hoist machine.

(12) Defective selector/assembly.

(13) Missing top emergency covers.

(14) Defective escalator fire shutters.

(15) Defective escalator comb plates.

(16) Defective escalator stop switch.

(17) Excessive escalator skirt panel clearances.

(18) Defective or non-functional safety switches.

(19) Badly worn, defective, or damaged relays or controllers and/or selector.

(20) Defective, badly worn, or damaged car safety device parts.

(21) Defective car and/or counterweight buffers.

(22) Any damaged, badly worn or defective equipment, which could result in elevator breakdown.

(b) *Civil penalties.* In the event any person fails to remove any of the violations listed in these rules, after having been served with a notice personally or by a certified mail indicating that removal of such condition exists and requiring such removal or compliance unless the removal of such condition is prevented by a labor dispute or is the result of vandalism beyond the control of the owner, he shall be liable for civil penalty of not less than one hundred fifty dollars per day commencing on the date of the service of such notice and terminating on the date that such removal or compliance has been substantially completed in addition to other penalties set forth in law. When service of such notice is made by mail to the owner, civil penalties as herein provided shall commence five days from the date of such mailing.

(c) *Discontinuance of action upon removal of violation.* Where a notice requiring removal of a violation listed in these rules has been issued, liability shall cease and the corporation counsel, on request of the commissioner, shall discontinue prosecution only if the removal or compliance so required has been completed or substantially completed within ten days after the service of such notice. The commissioner shall, upon good cause shown, grant additional time for such removal or compliance. In addition, the civil penalties shall be tolled from the date the owner certifies under oath, on [sic] a form prescribed by the commissioner, that the removal of the violation has been substantially completed. If subsequent inspection by the department shows a failure to have removed the violation, the civil penalties shall be deemed to have accrued as of the first day notice of violation has been served.

§11-03 Cease Use Orders for Elevators, Personnel Hoists, Escalators and Moving Walks.

A cease use order should be issued for all elevators, personnel hoists, escalators, and moving walks pursuant to §26-127 of the Administrative Code of the City of New York whenever an imminently hazardous condition exists. In addition, the device should be tagged as unsafe. This tag may not be removed without prior approval from the Department of Buildings. Such imminently hazardous conditions include but are not limited to:

(a) Elevator running with an open hoistway door or car gate/door.

(b) Elevator running with broken or non-functioning upper or lower final hoistway or machine limit switches.

(c) Hoistway or car door vision glass and grille guard missing.

(d) Unraveling or broken hoist, counterweight, governor or compensation cables.

(e) Missing hoistway door or car door gibs.

(f) Inoperable governor.

(g) Elevator running with non-functioning interlock.

(h) Emergency top exit cover missing (passenger elevator).

(i) Side emergency exit door open (passenger elevator).

(j) Emergency stop switch not working (automatic elevator,

Rules and Regulations

[sic] escalator or moving walk).

(k) Directional switch not working (escalator or moving walk).

(l) Other imminently hazardous conditions as observed by the inspector.

§11-04 Separability. If any of the provisions of these rules are found by a court of competent jurisdiction to be invalid or ineffective in whole or in part, the effect of such decision shall be limited to those provisions that are expressly stated in the decision to be invalid or ineffective, and all other provisions of these rules shall continue to be separately and fully effective.

§11-05 Certification of Completion of Work after Issuance of Temporary Use Permit for an Elevator, Escalator and other Device, Except Amusement Devices, Listed in §§27-184(b) or 27-982 of the Administrative Code.

(a) Where the department has issued a temporary use permit pursuant to §27-188 of the Administrative Code for an elevator, escalator or other device listed in §27-185(b) and §27-982 of the Code subject to the completion of alteration or installation work as specified by the department, a certified elevator inspection agency director, professional engineer or registered architect may certify to the department that such work has been completed in conformity with the requirements of Subchapter 18 of Chapter 1 of Title 27 and Reference Standard 18-1. The department shall issue an equipment use permit upon the satisfactory filing of such certification.

(b) This section shall not apply to amusement devices.

§11-06 Elevators, Escalators or Other Devices, Except Amusement Devices, Listed in §27-185(b) or §27-982 of the Administrative Code, Renewal of Temporary Use Permits and Fees.

(a) *Renewal of a temporary use permit for an elevator, escalator or other device, except amusement devices, listed in §27-185(b) or §27-982 of the Administrative Code.*

(1) A temporary use permit issued pursuant to §27-188 of the Administrative Code for an elevator, escalator or other device listed in §27-185(b) or §27-982 of the Code may be renewed subject to the following:

(i) Each renewal application shall be submitted on forms furnished by the department not later than five business days prior to the expiration date of the temporary use permit;

(ii) Such application shall state the reason for renewal and be accompanied by the required fee as set forth in subdivision (3) of this section; and

(iii) Such application shall be submitted on behalf of the owner and signed by the owner or its authorized representative.

(2) The commissioner will automatically renew a temporary use permit every thirty days for up to 120 days unless informed otherwise by the applicant. After 120 days, a renewal application must be filed and accompanied by the required fee.

(3) The department may require a department inspection prior to the issuance of a renewal.

(4) Each application for renewal shall be accompanied by a fee of \$100 per device.

(b) *Failure to keep or be prepared for scheduled appointment.*

(1) Scheduled appointments for the inspection or tests of an elevator, escalator or other device listed in §27-185(b) and §27-982 of the Code may be canceled provided that notice of cancellation is received by the department no later than 3 business days prior to the scheduled appointment.

(2) Where a department inspector arrives at the site of a

scheduled inspection or test and is unable to perform the scheduled inspection or witness the test because the owner or its authorized representative has failed to keep or is unprepared for the scheduled appointment, then the department shall impose a fee for the missed appointment in the amount of \$200. The fee shall be due and payable within thirty days after the date of the missed appointment or prior to the scheduling of a new appointment, whichever is earlier.

(c) *Pre-inspection clearance.* (1) An owner or its authorized [sic] representative may request the department to perform a pre-inspection clearance of an elevator, escalator or other device listed in §27-185(b) and §27-982 of the Administrative Code within five business days of the department's receipt of such request and payment of the required fees set forth in subdivision (2) of this section. The department reserved the right to schedule the requested pre-inspection clearance during non-regular or off-peak hours.

(2) A request for a pre-inspection clearance shall be accompanied by a non-refundable fee in the amount of \$200 per device.

(c) This section shall not apply to amusement devices.

CHAPTER 12 EMERGENCY POWER SYSTEMS

§12-01 Emergency Power System Requirements.

(a) *Applicability.* – Pursuant to Article 11 of subchapter 6 of Chapter 1 of Title 27 of the Administrative (Building) Code, as enacted by Local Law 16 for the year 1984, these rules and regulations shall apply to emergency power systems associated with emergency fire protection equipment when required to be provided in new and existing buildings pursuant to applicable provisions of the Building Code, the Building Code Reference Standards and the Rules of the City of New York.

(1) These rules shall not apply to occupant optional sources of emergency power that provide support for sources supplying emergency power to emergency fire protection equipment only in the event of failure of the sources of emergency power.

(2) These rules shall not apply to emergency power systems installed pursuant to plans approved prior to October 1, 1984 unless construction pursuant to any such plans had not begun prior to April 1, 1986.

(3) Subdivisions (h), (n) and (o) shall not apply to required emergency power systems for which applications were filed prior to September 9, 1998.

(4) Subdivision (p) shall not apply to required emergency power systems for which applications were filed prior to the effective date of this amendment.

(b) *Definition* - As used in these rules, "emergency fire protection equipment" shall mean that equipment listed in Section 27-396.4 of the Administrative Code.

(c) *General equipment requirements.* Emergency power systems shall have a power source and fuel supply sufficient to operate the following equipment:

(1) *Fire pumps and booster pumps.* Manual, automatic special service pumps and sprinkler booster pumps.

(i) Overcurrent protection shall be provided at the emergency generator side of the power distribution system and shall be rated at least 150% of motor full load current.

(ii) Feeder conductors on the emergency generator side of the power distribution system shall be sized at least 125% of motor full load current.

Rules and Regulations

(iii) Automatic transfer switches shall be located in the same room as the pumps and shall be an integral part of the pump controller.

(2) *Elevators.* Three elevators at one time, with manual transfer to all other elevators.

(i) The shaft arrangement shall permit any floor to be served by three elevators - only two of which may be in the same shaft.

(ii) It shall be possible to select from all of the elevators (with more than 25 feet travel) any combination of three cars for simultaneous operation in the emergency power mode, and to readily change this selection for firefighting or building evacuation purposes.

(iii) The selection of cars shall be accomplished manually from the elevator dispatcher's panel or from a satellite elevator panel if the main panel is not at, or adjacent to, the lobby Fire Command Station.

(iv) Interlocking shall be provided to prevent more than the intended number of cars from operating simultaneously in the emergency power mode.

(3) Alarm systems.

(4) Communication systems.

(5) Emergency lighting, if battery packs are not provided.

(6) Ventilating systems used for smoke venting or control.

(7) Stair pressurization.

(8) *Gas fired equipment.* The construction and installation of gas fired equipment shall comply with Article 16 of Subchapter 14 of Chapter 1 of Title 27 of the Administrative Code.

(9) *Fuel oil equipment.* Fuel oil equipment shall comply with Article 17 of Subchapter 14 of Chapter 1 of Title 27 of the Administrative Code

(d) *Responsibility.* The design of the emergency power system shall be the responsibility of the Licensed Professional Engineer or Registered Architect.

(e) *Engineering design.* - The emergency power systems shall be designed in accordance with generally accepted engineering practice, the Administrative (Electrical) Code and Bureau of Electrical Control Rules and Regulations.

(f) *Capacity.*

(1) The emergency generator fuel supply shall be sufficient to supply the total emergency power load for a period of at least six (6) hours.

(2) If battery packs are used for emergency lighting, they shall comply with the requirements of the Bureau of Electrical Control.

(g) *Automatic transfer switch features.*

(1) *Time delay on starting of alternate power source.* A time delay device may be provided to delay starting of the alternate source generator. The timer is intended to prevent nuisance starting of the alternate source generator with subsequent load transfer in the event of harmless momentary power dips and interruptions of the normal source. The time range must be short enough so that the generator can start and be on the line within 30 seconds of the onset of failure.

(2) *Time delay on transfer to alternate power.* An adjustable time delay device shall be provided for those transfer switches requiring "delayed automatic" operation. The time delay shall commence when proper alternate source voltage and frequency are achieved. The delay device shall prevent transfer to the alternate power source until after expiration of the preset

delay.

(3) *Time delay on retransfer to normal power.* An adjustable timer with a bypass shall be provided to delay retransfer from the alternate source of power to the normal. This timer will permit the normal source to stabilize before retransfer to the load and help to avoid unnecessary power interruptions. The bypass shall permit automatic retransfer in the event that the alternate source shall fail and the normal source is available.

(4) *Test switch.* A test switch shall be provided on each automatic transfer switch that will simulate a normal power source failure to the switch.

(5) *Indication of switch position.* Two pilot lights, properly identified, shall be provided to indicate the transfer switch position.

(6) *Manual control of switch.* A means for the safe manual operation of the automatic transfer switch shall be provided.

(7) *Nonautomatic transfer device classification.* Nonautomatic transfer devices shall be approved for emergency electrical service.

(8) *Indication of switch position.* Pilot lights, properly identified, shall be provided to indicate the switch position.

(h) *Automatic Transfer Devices and Power Generation Feeders.*

(i) *New buildings.* - (i) All automatic transfer devices, emergency generators and emergency power generation feeders that serve required emergency fire protection equipment shall not be located in the same room as the main or primary electrical service equipment.

(ii) Any automatic transfer device that is not located at the load shall be located within an enclosed room or space that has a 2-hour fire resistance rated enclosure, and that complies with the New York City Electrical Code requirements for Electrical Closets and Switchboard Rooms or Areas. The enclosed room or space shall contain no equipment or water and/or steam piping other than sprinkler piping and equipment associated with the emergency fire protection equipment. Uninterrupted conduits not associated with the emergency generation system may pass through this room or space.

(2) *Existing buildings.* - (i) Emergency power generation feeders and automatic transfer devices that are required to be installed in existing buildings pursuant to Section 27-115 or 27-118(a) of the Administrative Code shall not be located in the same room as the main or primary electrical service equipment.

(ii) Any automatic transfer device that is not located at the load shall be remotely located or separated by 2-hour fire resistance rated construction from the emergency generator and any fuel burning equipment.

(i) *Ventilating Air.* Provision shall be made to provide air adequate to replenish engine combustion and adequate for rejection of engine generated heat.

(j) *Application.* The emergency power system shall be filed with the following application: Plumbing, Mechanical Equipment and Tank Installation; Miscellaneous B Form 8.

(k) *Certificate of Electrical Inspection.* A licensed electrician shall file an application for a Certificate of Electrical Inspection with the Bureau of Electrical Control for the Emergency Power System.

(l) *Registration.* Emergency power generation equipment shall be registered with the Department of Environmental Protection, Bureau of Air Resources, in accordance with the

Rules and Regulations

requirements of §24-109 of the Administrative Code.

(m) *Inspection and test.* Generator sets serving Emergency Power Systems shall be inspected and tested monthly under the supervision of any of the following:

- (1) A Licensed Professional Engineer or Registered Architect.
- (2) An electrician licensed by the Bureau of Electrical Control.
- (3) An electrician holding a Special License (Maintenance, for a specific building only) from the Bureau of Electrical Control.
- (4) The Fire Safety Director having a Certificate of Fitness from the Fire Department.

The Stationary Engineer or Assistant Stationary Engineer having a Certificate of Fitness from the Fire Department.

(n) Emergency generators installed indoors in new buildings shall be located within a room or space that has a two (2) hour fire resistance rating enclosure. The room or space shall contain no equipment or water and/or steam piping other than sprinkler piping, equipment and fuel tanks associated with the emergency generation systems, and shall be located away from areas that may be prone to flooding or damage from other natural causes.

Emergency generators installed indoors in existing buildings shall be located within a room or space that has a two (2) hour fire resistance rating enclosure.

For new and existing buildings, uninterrupted conduits not associated with the emergency generation system may pass through this room or space. Emergency generators within such room or space may supply occupant optional loads in addition to those of the emergency fire protection equipment provided the emergency fire protection equipment loads are given the highest priority. Load shedding or other means acceptable to the Commissioner shall be used to ensure that this priority assignment is maintained under all operational conditions. Multiple generators supplying emergency fire protection equipment loads only, or emergency fire protection equipment in combination with occupant optional loads as a common system, may have common fuel supplies and other common equipment and systems. Generators dedicated only to supplying emergency fire protection equipment loads may have fuel supplies, other equipment and systems in common with generators dedicated to occupant optional loads. The fuel system for the operation of the emergency power system supplying the emergency fire protection equipment loads shall consist of an on-site fuel oil system providing a minimum of six hours capacity at full load at all times except during loss of utility power. Occupant optional loads shall be shed and emergency fire protection equipment shall restore to utility power, if available, to comply with this requirement. Means shall be provided for automatic transfer to the fuel oil supply upon loss of gas supply where dual fuel generators are used.

(o) Water-cooled emergency generators shall not rely solely upon a single city water connection. The additional source of water for cooling may be obtained from:

- (i) another water main connection;
- (ii) a suction tank;
- (iii) a gravity tank; or
- (iv) any other system acceptable to the commissioner.

(p) Circuits for emergency lighting in any area required to be provided with emergency lighting shall be arranged so that loss of normal or emergency power supply shall not reduce

the available lighting levels in any of such areas below the level required for emergency lighting by applicable provisions of the Administrative Code, Reference standards or Rules of the City of New York. This may be accomplished by means of a combination of wiring arrangement and emergency power connection.

CHAPTER 13 ADJUDICATIONS

Subchapter A * [REPEALED]

**Repealed per 1 RCNY 102-01 effective 7-1-08.*

Subchapter B

Rules Governing Adjudication Procedures

§13-11 Purpose.

(a) These rules are instituted in order to establish guidelines for the adjudication procedures of the Department of Buildings (“the Department”). Pursuant to City Charter §1048, all hearings concerning the following matters under the jurisdiction of the Department will be held before the Office of Administrative Trials and Hearings (“OATH”) and governed by the rules of procedure utilized at that tribunal:

- (1) Welder License Revocation
- (2) Boiler Operating License Revocation
- (3) Hoisting Machine Operator License Revocation
- (4) Rigger License Revocation
- (5) Sign Hanger License Revocation
- (6) Oil-Burning Equipment Installer License Revocation
- (7) Concrete Testing Laboratory License Revocation
- (8) Exclusion from the Limited Supervisory Check and/or Professional Certification Program for Plans filed by Registered Architects or Licensed Professional Engineers pursuant to 1 RCNY 21-01 *et seq.*
- (9) Civil Service Employee Disciplinary Matters, subject to §1.3 herein
- (10) Sealing orders, pursuant to §26-127(e)(i) of the New York Administrative Code.
- (11) The suspension or revocation of the registration, or the limitation of registration, of persons required to be registered with the Department pursuant to Administrative Code §27-140.1.
- (12) The suspension or revocation of the authority of any Department licensee, certified inspection agency, or any other authorized representative of the Commissioner to conduct inspections of work or participate in any self-certification program under the jurisdiction of the Department, except that such proceedings relating to Master Plumbers, Master Fire Suppression Piping Contractors, and Master Electricians may be adjudicated at OATH only upon referral by the applicable license board pursuant to paragraph (b)(i) below.
- (13) The suspension or revocation of certificates of approval for private elevator inspection agencies, directors, and inspectors certified pursuant to §11-01 of Title 1 of the Rules of the City of New York.
- (14) A petition by which the Department seeks an order of removal of an outdoor sign and/or sign structure pursuant to section 26-127.3 and/or section 26-262(d) of the Administrative Code.

Rules and Regulations

(15) A petition by which the Department seeks to revoke or suspend the registration of an outdoor advertising company and /or impose a fine or other penalties, pursuant to section 26-260(d) of the Administrative Code.

(16) A petition by which the Department seeks an order of suspension or revocation of the registration of a Construction Superintendent.

(17) A petition by which the department seeks an order of suspension or revocation of the approval of an approved agency.

(b) (1) Notwithstanding the procedures set forth in §§13-12 through 13-21 of these rules, upon referral by the Master Electricians License Board (established pursuant to §27-3009 of the Administrative Code) or the Master Plumbers/Master Fire Suppression Piping Contractors License Board (established pursuant to §26-144 of the Administrative Code) (either Board hereinafter referred to as the "Board"), hearings concerning the following matters may be held before OATH and be governed by the rules of procedure of such tribunal:

(i) Master Plumbers License, pursuant to Administrative Code §26-151.

(ii) Master Fire Suppression Piping Contractor License, pursuant to Administrative Code §26-151.

(iii) Master Electrician License, pursuant to §27-3016 of the New York City Administrative Code.

(2) After conducting an adjudicative hearing on a matter referred to it by the Board, the Administrative law judge at OATH shall issue recommended findings of fact and a recommended decision, and forward such findings and recommended decision and the record of the proceedings to the chairperson of the Board. The chairperson shall provide copies of such findings and recommendation to members of the Board at least ten days before that meeting of the Board at which action on such recommendation is scheduled to be taken. The Board shall act on such recommendations at such meeting and forward such recommendations and record, together with its own comments, if any, to the Commissioner. If the Board fails to act on a matter referred to it by OATH at such meeting, the OATH findings and recommendations shall be deemed to be adopted in full by the Board and shall be forwarded by the chairperson to the Commissioner for review. The Commissioner shall make the final determination.

(c) New York City Department of Buildings' adjudications regarding the fitness and discipline of agency employees will be conducted by OATH. After conducting an adjudication and analyzing all testimony and other evidence, the hearing officer shall make written proposed findings of fact and recommend decisions, which shall be reviewed and finally determined by the Commissioner.

§13-12 Definitions.

Board. The term "board" shall hereafter mean the Master Electricians License Board established pursuant to Administrative Code §27-3009 or the license board established pursuant to Administrative Code §26-144 which has jurisdiction over licensed master plumbers and licensed master fire suppression piping contractors.

Chairperson. The term "chairperson" shall mean the chairperson of the board or any other person authorized to act as chairperson. In any case where the chairperson is absent, another member of the board may act as chairperson.

Charging panel. The term "charging panel" shall mean the panel established pursuant to Administrative Code §26-144(c) to investigate complaints and any charges arising therefrom.

Commissioner. The term "commissioner" shall mean the Commissioner of Buildings of the City of New York, or any person or persons he or she lawfully appoints as designee.

Hearing panel. The term "hearing panel" shall hereafter mean the panel established pursuant to Administrative Code §26-151(b).

Presiding member. The term "presiding member" shall mean the person designated by the chairman to preside at investigations and hearings. In any case where the presiding member is absent, another member of the charging panel or hearing panel may act as the presiding member.

Quorum. The term "quorum" shall mean the number of charging panel or hearing panel members required to be present in order to conduct investigations and hearings and shall consist of a majority of the members of the charging panel or hearing panel.

Respondent. The term "respondent" shall hereafter mean the holder of an electrician's license, plumber's license, master fire suppression license, or any other person or entity who is the subject of a disciplinary proceeding as hereinafter provided.

§13-13 Pre-Hearing Procedure.

(a) Prior to the commencement of formal proceedings the Commissioner or board may, in his or their discretion, schedule a respondent for a pre-investigatory conference, pursuant to §646 of the New York City Charter, to determine the propriety of either (a) preferring charges against the respondent, or (b) determining the respondent's fitness to qualify for or hold a license, as the case may be.

§13-14 Commencement of Disciplinary Proceedings. (a) A disciplinary proceeding shall be commenced by the filing of charges and specifications with the board. Such charges and specifications may be filed by the board itself, a member of the board, the Department of Buildings or any other governmental agency. Notwithstanding the foregoing, all such proceedings shall be prosecuted by the Department of Buildings.

(b) The charges and specifications shall contain the name of the respondent sought to be disciplined, reference to the provisions of law alleged to have been violated and the factual allegations underlying the charges. The chairperson may request individuals, at least two of whom shall be members of the board, to act as a charging panel with the approval of the board. The chairperson shall appoint one member of the charging panel to act as the presiding member. The charging panel shall review the charges and by a quorum approve, disapprove or where appropriate, modify them. The finding of the charging panel as to the sufficiency, definiteness or detail of the statement or its failure or refusal to furnish a more definite or detailed statement shall not be subject to judicial review.

(c) Unless otherwise provided by Title 26 of the New York City Administrative Code, if the charging panel approves or modifies the charges, a copy of the charges and

Rules and Regulations

specifications, together with a date, time and place for hearing, shall be personally delivered or mailed to the respondent at the respondent's place of business or usual place of abode.

(d) The chairperson may request three individuals, at least two of whom shall be members of the board, to act as a hearing panel with the approval of the board. The chairperson shall appoint one member of the hearing panel to act as the presiding member. None of the individuals appointed to the hearing panel shall be an employee of the Department of Buildings.

(e) Unless otherwise provided by Title 26 of the New York City Administrative Code, within ten calendar days if the charges are delivered personally, or within fifteen calendar days if the charges are mailed, said period accruing on the date of delivery or mailing as the case may be, the respondent shall file with the hearing panel a written statement denying, admitting or admitting with an explanation any or all of the charges and specifications. Where a respondent admits with an explanation, it shall not be necessary to provide that explanation until such time as the hearing panel requests it.

(f) Where the respondent is a licensee, if the respondent fails to appear at the hearing, the hearing panel may recommend to the Commissioner that the respondent's license be suspended until such time as the respondent appears.

(g) Notwithstanding the foregoing, if upon the filing of charges and specifications, or at any time thereafter, the Commissioner should determine that there exists a serious and immediate threat to persons or property by the conduct alleged, the respondent's license may be suspended immediately, provided, however, that in any such case the respondent shall have a right to a hearing at the next available hearing date following the date of suspension.

§13-15 Disclosure.

(a) Requests for a bill of particulars shall be made in writing and served upon the department advocate and directed to the presiding member of the hearing panel at least ten calendar days prior to the hearing. Such requests shall be granted only for good cause shown.

(b) Objections to such requests shall be submitted to the presiding member of the hearing panel at least five business days prior to the hearing. Such an objection, however, shall not be a prerequisite to the presiding member's decision to deny or limit such request.

§13-16 Adjournments. Requests for adjournments or extensions of time may be granted by the presiding member of the hearing panel for good cause shown.

§13-17 Subpoenas. (a) Subpoenas shall be submitted to the presiding member for signature any time prior to the scheduled hearing date, and shall be served by the party requesting the subpoena in the manner prescribed by the Civil Practice Law and Rules.

(b) The presiding member of the hearing panel may, for good cause shown, permit an adjournment for the purpose of permitting or making a motion in the Supreme Court to compel compliance with a subpoena.

(c) In any case where the holder of a license is subpoenaed but fails to appear, the hearing panel may recommend to the Commissioner that such license be immediately suspended.

§13-18 Conduct of Hearings.

(a) Hearings shall be conducted by at least a quorum of the members of the hearing panel.

(b) Oaths or affirmations shall be administered to all witnesses called to testify.

(c) Evidence shall first be proffered in support of the charges. The respondent shall have the right to object to the evidence and to cross-examine witnesses.

(d) When all of the evidence in support of the charges is presented to the hearing panel, the respondent may present evidence in rebuttal, which may also be subject to objections and cross-examination by an adverse party.

(e) At any stage of the hearing the presiding member may permit members of the hearing panel to examine witnesses or review any other evidence.

(f) The hearing panel may independently introduce its own exhibits or call and examine its own witnesses.

(g) All objections shall be directed to the presiding member, who shall rule on them.

(h) Hearsay evidence is admissible at the discretion of the presiding member, provided, however, that such evidence must be relevant to the charges.

(i) Parties may be permitted to make opening and closing statements, and to submit written argument on the law and the facts at the conclusion of oral testimony.

(j) Respondents may be represented by an attorney at all stages of the proceedings.

§13-19 Board Initiated Investigatory Hearings.

(a) Nothing contained herein shall be deemed a limitation of the board's statutory obligation pursuant to Administrative Code §§26-144(a), (c) and 27-3009(c) to conduct investigatory hearings. Such hearings shall not be governed by these rules of procedure.

§13-20 Evidentiary Standard of Proof.

(a) The burden of proof shall be on the party initiating the proceeding. The hearing panel shall utilize a preponderance of the evidence standard of proof with respect to any recommendation calling for the imposition of a fine, suspension or revocation of license.

§13-21 Decisions, Determinations and Orders. (a) Any decision, determination or order of the hearing panel shall be by a quorum. It shall be in the nature of a recommendation and shall be transmitted to the commissioner or his designee, and shall consist of findings of fact and conclusions of law. Hearing panel members who do not concur with the recommendation may submit a separate recommendation.

(b) A copy of the written recommendation of the hearing panel shall be delivered or mailed forthwith to each party.

(c) The decision, determination or order of the hearing panel shall not be binding until reviewed by the Commissioner or his or her designee, who in his or her discretion, may adopt, reject or modify said recommendation. The final decision, determination or order of the Commissioner shall then be promptly delivered or mailed to each party.

(d) Any decision, determination or order of the Commissioner or his or her designee may be reviewed as provided by law.

CHAPTER 14 FEES

***[REPEALED]**

**Repealed per 1 RCNY 100-03 effective 7-1-08.*

Rules and Regulations

CHAPTER 15 FIRE PROTECTION

§15-01 Communication and Alarm Systems ("Mini-Class 'E' Systems") for Certain Buildings under 100 Feet in Height.

(a) *Number of occupants.* The subject subsection (27-972(h)) of the Building Code states that a communication and alarm system, acceptable to the Commissioner of Buildings, shall be provided in buildings classified in occupancy group E, less than 100 feet in height, occupied or arranged to be occupied for an occupant load of more than one hundred persons above or below the street floor or more than a total of five hundred persons in the entire building. The provisions regarding occupant load are to be interpreted to apply where one or more of the following prevail:

- (1) The sum of the occupants on all the floors below the street floor exceeds 100 persons; or
- (2) The sum of the occupants on all the floors above the street floor exceed 100 persons; or
- (3) A total of more than 500 persons in the entire building including the street floor.

(b) *Occupancy load.* Occupant load shall be determined by the existing certificate of occupancy. In the absence of such certificate of occupancy, the occupant load shall be the greater of the actual number of occupants or on the basis of 1 person per 100 square feet net floor area. Net floor area shall be all space within the building exterior walls, excluding the following areas:

- (1) areas enclosing stairs.
- (2) public corridors.
- (3) elevators and shafts.
- (4) rest rooms.
- (5) storage rooms.

(For example, a net floor area of 10,100 square feet is capable of an occupancy of 101 persons).

The Communication and Alarm System, acceptable to the Commissioner of Buildings, shall have the following capabilities and components:

(c) *Capabilities and components.* (1) Fire command station. A communications center, located in the lobby of the building on the entrance floor as part of the elevator control panel if such exists, or located in the immediate vicinity of the elevators if they exist, to provide:

(i) Individual two-way voice communication from the fire command station to a fire warden station on each floor and to the regularly assigned location of the fire safety director, to consist of a telephone handset or approved speaker microphone system or other approved voice communication system. Initiation of a call from the fire command station shall sound a loud and distinctive sound or an audible device, selectively on the entire floor which is being called or at all floors throughout the building, through the use of a general all call button. This call shall be immediately answered by the fire wardens of the floors involved.

(ii) Manual pull station located adjacent to the fire command station to transmit a fire alarm signal to the fire department via a central station of a franchised operating company.

(iii) Annunciation of associated fire safety systems at the fire command station is optional; however, such annunciation shall not be connected to the mini-class

"E" system.

(iv) This system shall be a "supervised" system. A "supervised" system is one that is electrically monitored so that the occurrence of a single open or single ground fault condition of its wiring which prevents the required normal operation of the system or causes the failure of its primary (main) power supply source is indicated by a distinctive trouble signal.

(2) Fire Warden Station. A station located on each floor within view of the passenger elevator lobby if such exists; however, when an elevator lobby does not exist, the station shall be located in the path of egress to an exit stairway. The fire warden station shall have two-way communication with the Fire Command Station and:

(i) Shall consist of telephone handset or a speaker microphone system or other approved equivalent voice communication system.

(ii) The initiation of a call from a fire warden shall cause a loud and distinctive sound at the Fire Command Station and at the Fire Safety Director's Office, which call shall be immediately answered by the Fire Safety Director from the Fire Command Station.

(3) Fire Safety Director's Office. A station located within the building at the principal work location of the Fire Safety Director arranged the same as a warden's station. There shall be a two-way voice communication system to the Fire Command Station. A two-way voice communication system described above shall also be provided at the mechanical control center should one exist.

(4) General requirements.

(i) The components of the system shall require New York City Department of Buildings Material Equipment Acceptance ("M.E.A.") approval.

(ii) A. SOURCES OF ELECTRICAL POWER

Two sources of electrical power shall be provided as follows:

1. The primary source shall be generated electric power not exceeding 277/480 volts, supplied by utility company power, or isolated plant.

2. The secondary source shall be an emergency power system (as per Section 27-396 of the Building Code), an emergency generator and/or battery power.

3. One source of power shall be connected to the system at all times. The primary and secondary power sources shall be so arranged and controlled by automatic transfer switches and/or circuitry that when the primary source of power fails, the secondary source will be connected automatically to the fire alarm signal system. Intermediary devices between the system supply and the source of power, other than fused disconnect switches, transformers, fused cutouts and automatic transfer switches, are prohibited. Such disconnect switches, cutouts, transformers and automatic transfer switches shall supply only the fire alarm system and other systems covered by this reference standard. When the utility company requires the installation of metering current transformers, the system supply shall be connected on the load side of the current transformers. All installations shall comply with the applicable sections of the New York City Electrical Code.

The primary source of power and the secondary source (if said secondary source is an emergency power system or generator) shall each be provided with a means of disconnect from the fire alarm system. For buildings supplied at 120/208 volts, each disconnect shall consist of a fused cutout panel, utilizing cartridge fuses, with provision for interrupting the unfused neutral and all ungrounded conductors. The neutral shall be provided

Rules and Regulations

with a removable solid copper bar. The incoming service neutral shall be bonded to the metallic housing of the cutout panel on the line side of the removable bar. The fused cutout panel housing shall consist of a locked metallic cabinet with hinged door, painted fire department red, and permanently identified as to the system served. For buildings served at 265/460 volts, the primary and secondary service disconnects shall be fused disconnect switches (in lieu of fused cutout panels) in locked, red painted, permanently identified enclosures. The service voltage shall be transformed to 120/208 volts and a fused cutout panel provided within 5 feet of the transformer on the 120/208 volt side. The incoming supply connections shall comply with the New York City Electrical Code, and the fused cutout panel shall comply with the requirements specified herein before.

B. PRIMARY POWER SOURCE

The primary service to the fire alarm system shall be so arranged that the building source of supply can be disconnected without de-energizing the fire alarm supply. To accomplish this, the primary fire alarm supply shall be connected ahead of all building over current protection and/or switching devices.

C. SECONDARY POWER SOURCE

The secondary service to the fire alarm system shall be provided as follows:

1. If the building has a required emergency power system, the secondary source shall be the emergency power system, regardless of whether the primary source is utility company power or an isolated plant.
2. If the building has an emergency generator supplying power to any of the loads listed in Section 27-396.4 of the Building Code, the secondary source shall be the generator.
3. For all other buildings, the secondary source shall be a battery supply provided in accordance with Reference Standard 17-5 for storage batteries. The battery shall be designed for 24-hour supervisory operation of the system, followed by 15 minutes of total system load.

(iii). WIRING

A. Power Conductors (Above 75 volts) shall be:

1. Copper: THHN, THWN\THHN, TFFN, TFN, FEP, RHH, RHW-2, XHH, or XHHW minimum 600 volts; 90 C; for installation in rigid metallic conduit (RMC), intermediate metallic conduit (IMC) or electric metallic tubing (EMT).

2. Cable type MI, M.E.A. approved for fire alarm service.

B. Low Voltage Conductors (75 volts and less) shall be:

1. Copper: THHN, THWN\THHN, TFFN, TFN, FEP, RHH, RHW, XHH, or XHHW minimum 600 volts; 90 C; for installation in rigid metallic conduit (RMC), intermediate metallic conduit (IMC) or electric metallic tubing (EMT)

2. Minimum wire size No. 18 AWG.

3. Multi-conductor cables run in raceways, or exposed as described hereinafter, shall meet the following additional requirements:

(a) Type FPLP only; minimum insulation thickness 15 mils; minimum temperature 150 C; colored red.

(b) Red colored jacket overall; minimum thickness 25 mils.

(c) Cable printing as per UL1424; must bear additional description "ALSO CLASSIFIED NYC CERT. FIRE ALARM CABLE" legible without removing jacket.

C. Installation of Conductors and Raceway shall be in accordance with the following:

1. Power conductors shall not be installed in common raceways with low voltage conductors.

2. Comply with applicable requirements of New York City Electrical Code, except where requirements are exceeded by this Reference Standard.

3. Conductors other than M.I. cable shall be run in raceway, except as specifically described below.

4. Multi-conductor cables may be installed without raceway protection where cable is protected by building construction. Where not protected by building construction, cables shall be located 8 feet or more above the finished floor and not subject to physical tampering or hazard. Locations within eight feet of the finished floor that are deemed as "protected by building construction" shall include raised floors, shafts, telephone and communication equipment rooms and closets, and rooms used exclusively for fire alarm system equipment.

5. All wiring within mechanical and elevator equipment rooms shall be run in raceways.

6. Raceways run within 8 feet of finished floor in garage areas, loading docks, mechanical rooms, and elsewhere where subject to mechanical damage, shall be rigid galvanized steel conduit only.

This space is intended to be left blank

Rules and Regulations

This page is intended to be left blank

Rules and Regulations

7. Where wiring is required to be run in raceway, install conductors in rigid metallic conduit (RMC), intermediate metallic conduit (IMC) or electric metallic tubing (EMT), except that multi-conductor cables may also be run in surface metal raceway. Conductors for other electrical systems shall not be installed in raceways containing REFERENCE STANDARD 17 conductors.

8. Where allowed to be run without raceway protection, multi-conductor cables shall be installed as follows:

(a) Cables shall not depend on ceiling media, pipes, ducts, conduits, or equipment for support; Cables must be supported independently from the building structure.

(b) Cables must be secured by cable ties, straps or similar fittings, so designed and installed as not to damage the cable. Cables must be secured in place at intervals not exceeding 5'-0" on centers and within 12" of every associated cabinet, box or fitting.

9. Installation of raceways, boxes and cabinets shall comply with the following general requirements:

(a) Covers of boxes and cabinets shall be painted red and permanently identified as to their use.

(b) Penetrations of fire-rated walls, floors or ceilings shall be fire stopped.

(c) Within stairways, raceways within 8 feet of the floor shall not be installed so as to reduce or obstruct the stairway radius.

(d) Raceways or cables shall not penetrate top of any equipment box or cabinet.

10. All conduits supplying 120-volt power to the fire alarm control unit and/or to outlying control cabinets, shall contain a green insulated grounding conductor sized in accordance with the New York City Electrical Code (#10 AWG minimum). The grounding conductor shall be connected to the ground bus or other suitable grounding terminal in each box and cabinet in which it enters. At the fuse cutout panel supplying the fire alarm system, provide a grounding electrode conductor sized and installed in accordance with the New York City Electrical Code (#10 AWG minimum).

11. For cabinets whose 120 volt supply is not derived from the main fire alarm system cutout panel, provide green insulated separate grounding electrode conductors, sized and installed as per New York City Electrical Code (#10 AWG minimum). In steel-framed buildings, a connection to local steel structure will be acceptable.

12. Splices and terminations of wires and cables shall be as follows:

(a) Permitted only in boxes or cabinets specifically approved for the purpose.

(b) Utilize mechanical connections specifically approved by U.L.486 A & C for the conductors, or if soldered, first joined so as to be mechanically and electrically secure prior to soldering and insulating. Temperature rating of completed splices shall equal or exceed the temperature rating of the highest rated conductor.

13. Wiring for audible notification devices shall be arranged so that a loss of a portion of the wiring on a floor will not render more than 60% of the devices inoperative, and the devices shall be so connected to the circuitry (i.e. by means of alternate circuits) as to maintain at least partial audibility throughout the entire floor.

(iv) The name and telephone number of the central office company shall be displayed at the manual pull station.

(v) There shall be a Fire Safety Director on duty at all times that the premises is actually occupied by the number of persons specified in the opening paragraphs of these rules. The Director shall have a Certificate of Fitness issued by the New York City Fire Department.

(vi) Applications shall be filed and permits obtained as required by departmental memoranda concerning fire alarm systems.

§15-02 Interior Fire Alarm and Signal System for Place of Assembly Used as a Cabaret and for Stages, Dressing Rooms and Property Rooms.

(a) *Number of occupants.* Subdivisions 27-968(a)(10)(a) and (b) of the Building Code state that an interior fire alarm and signal system shall be provided in any room, place or space occupied or arranged to be occupied by 75 or more persons and in which either any musical entertainment, singing, dancing or other form of amusement is permitted in connection with the restaurant business or the business of directly or indirectly selling to the public food or drink, or where dancing is carried on and the public may gain admission, with or without payment of a fee, and food or beverages are sold, served, or dispensed, and any new or altered catering place as of April 4, 1979 having 300 or more persons. This does not apply to eating or drinking places which provide incidental musical entertainment, without dancing, either by mechanical devices, or by not more than three persons playing piano, organ, accordion or guitar or any stringed instrument or by not more than one singer accompanied by himself or a person playing piano, organ, accordion, guitar or any stringed instrument.

(b) *Occupant load.* The occupant load of a Place of Assembly shall be calculated by dividing the net floor area of the space by the appropriate figure in the following table:

| Occupancy | Net Floor Area per Occupancy (square feet) |
|--|--|
| (1) Dance Floor | 10 |
| (2) Dining Spaces | 12 |
| (3) Standing Room (Audience) in all Places of Assembly | 4 |
| (4) Seating Area (Audience) in all Places of Assembly | |
| (i) Fixed Seats | Designed Number of Seats or Occupants |
| (i) Movable Seats | 10 |

(c) *Capabilities and components.*

(1) Fire Alarm System: shall be closed circuit, "electrically supervised", individually coded and connected to an approved franchise/central office alarm company.

A "supervised" system is one that is electrically monitored so that the occurrence of a single open or single ground fault condition of its wiring which prevents the required normal operation of the system or causes the failure of its primary (main) power supply source is indicated by a distinctive trouble signal.

(i) Manual fire alarm stations: shall be installed at each required natural path of egress from all levels from public assembly area.

(ii) Fire alarm gongs: shall be installed to provide adequate audibility throughout the Public Assembly area and all areas

Rules and Regulations

occupied in conjunction with the area at all levels including dressing rooms, rest rooms, coat rooms, etc. "Audibility" shall be loud and distinct under maximum sound system operation unless section 15-02(c)(2)(ii) is complied with.

(iii) Sprinkler waterflow device: shall be installed to indicate flow of water in the sprinkler system and shall be made part of the interior Fire Alarm by interconnecting the waterflow device to the interior Fire Alarm so that actuation of the waterflow device shall sound a distinctive coded alarm via the fire alarm gongs.

(2) General requirements.

(i) The components of the system shall require New York City M.E.A. approval.

(ii) A device may be installed to automatically turn off the sound system and psychedelic and special effects lighting when a manual fire alarm and/or sprinkler waterflow device is activated in all public assemblies that require an interior fire alarm and signal system.

(iii) A. SOURCES OF ELECTRICAL POWER

Two sources of electrical power shall be provided as follows:

1. The primary source shall be generated electric power not exceeding 277/480 volts, supplied by utility company power, or isolated plant.

2. The secondary source shall be an emergency power system (as per Section 27-396 of the Building Code), an emergency generator and/or battery power.

3 One source of power shall be connected to the system at all times. The primary and secondary power sources shall be so arranged and controlled by automatic transfer switches and/or circuitry that when the primary source of power fails, the secondary source will be connected automatically to the fire alarm signal system. Intermediary devices between the system supply and the source of power, other than fused disconnect switches, transformers, fused cutouts and automatic transfer switches, are prohibited. Such disconnect switches, cutouts, transformers and automatic transfer switches shall supply only the fire alarm system and other systems covered by this reference standard. When the utility company requires the installation of metering current transformers, the system supply shall be connected on the load side of the current transformers. All installations shall comply with the applicable sections of the New York City Electrical Code.

The primary source of power and the secondary source (if said secondary source is an emergency power system or generator) shall each be provided with a means of disconnect from the fire alarm system. For buildings supplied at 120/208 volts, each disconnect shall consist of a fused cutout panel, utilizing cartridge fuses, with provision for interrupting the unfused neutral and all ungrounded conductors. The neutral shall be provided with a removable solid copper bar. The incoming service neutral shall be bonded to the metallic housing of the cutout panel on the line side of the removable bar. The fused cutout panel housing shall consist of a locked metallic cabinet with hinged door, painted fire department red, and permanently identified as to the system served. For buildings served at 265/460 volts, the primary and secondary service disconnects shall be fused disconnect switches (in lieu of fused cutout panels) in locked, red painted, permanently identified enclosures. The service voltage shall be transformed to 120/208 volts and a fused cutout panel provided within 5 feet

of the transformer on the 120/208 volt side. The incoming supply connections shall comply with the New York City Electrical Code, and the fused cutout panel shall comply with the requirements specified in this rule.

B. PRIMARY POWER SOURCE

1. The primary service to the fire alarm system shall be so arranged that the building source of supply can be disconnected without de-energizing the fire alarm supply. To accomplish this, the primary fire alarm supply shall be connected ahead of all building over current protection and/or switching devices.

2. Partial systems such as strobe light control panels, partial fire alarm, automatic smoke/heat detection, and sprinkler alarm subsystems and/or other associated systems may be connected to an emergency supply riser panel via a tapped connection, and an identified, locked fused cutout box located within 5 feet of the tap. Where an emergency power system (E.P.S.) is provided in accordance with Section 27-396.4 of the Building Code, it shall be connected to the emergency supply riser. Where an E.P.S. is not available, the emergency supply riser shall be connected to a tap ahead of the service switch.

C. SECONDARY POWER SOURCE

The secondary service to the fire alarm system shall be provided as follows:

1. If the building has a required emergency power system, the secondary source shall be the emergency power system, regardless of whether the primary source is utility company power or an isolated plant.

2. If the building has an emergency generator supplying power to any of the loads listed in Section 27-396.4 of the Building Code, the secondary source shall be the generator.

3 For all other buildings, the secondary source shall be a battery supply provided in accordance with Reference Standard 17-5 for storage batteries. The battery shall be designed for 24-hour supervisory operation of the system, followed by 15 minutes of total system load.

(iv). WIRING

A. Power Conductors (Above 75 volts) shall be:

1. Copper: THHN, THWN\THHN, TFFN, TFN, FEP, RHH, RHW-2, XHH, or XHHW minimum 600 volts; 90 C; for installation in rigid metallic conduit (RMC), intermediate metallic conduit (IMC) or electric metallic tubing (EMT).

2. Cable type MI, M.E.A. approved for fire alarm service.

B. Low Voltage (75 volts and less) shall be:

1. Copper: THHN, THWN\THHN, TFFN, TFN, FEP, RHH, RHW, XHH, or XHHW minimum 600 volts; 90 C; for installation in rigid metallic conduit (RMC), intermediate metallic conduit (IMC) or electric metallic tubing (EMT)

2. Minimum wire size No. 18 AWG.

3 Multi-conductor cables run in raceways, or exposed as described hereinafter, shall meet the following additional requirements:

(a) Type FPLP only; minimum insulation thickness 15 mils; minimum temperature 150 C; colored red.

(b) Red colored jacket overall; minimum thickness 25 mils.

(c) Cable printing as per UL1424; must bear additional description "ALSO CLASSIFIED NYC CERT. FIRE ALARM CABLE" legible without removing jacket.

C. Installation of Conductors and Raceway shall be in accordance with the following:

Rules and Regulations

1. Power conductors shall not be installed in common raceways with low voltage conductors.
2. Comply with applicable requirements of New York City Electrical Code, except where requirements are exceeded by this Reference Standard.
3. Conductors other than M.I. cable shall be run in raceway, except as specifically described below.
4. Multi-conductor cables may be installed without raceway protection where cable is protected by building construction. Where not protected by building construction, cables shall be located 8 feet or more above the finished floor and not subject to physical tampering or hazard. Locations within eight feet of the finished floor that are deemed as "protected by building construction" shall include raised floors, shafts, telephone and communication equipment rooms and closets, and rooms used exclusively for fire alarm system equipment.
5. All wiring within mechanical and elevator equipment rooms shall be run in raceways.
6. Raceways run within 8 feet of finished floor in garage areas, loading docks, mechanical rooms, and elsewhere where subject to mechanical damage, shall be rigid galvanized steel conduit only.
7. Where wiring is required to be run in raceway, install conductors in rigid metallic conduit (RMC), intermediate metallic conduit (IMC) or electric metallic tubing (EMT), except that multi-conductor cables may also be run in surface metal raceway. Flexible metallic conduit, not exceeding 36" in length, shall be permitted for final connections to initiating and notification devices. Conductors for other electrical systems shall not be installed in raceways containing REFERENCE STANDARD 17 conductors.
8. Where allowed to be run without raceway protection, multi-conductor cables shall be installed as follows:
 - (a) Cables shall not depend on ceiling media, pipes, ducts, conduits, or equipment for support; Cables must be supported independently from the building structure.
 - (b) Cables must be secured by cable ties, straps or similar fittings, so designed and installed as not to damage the cable. Cables must be secured in place at intervals not exceeding 5'-0" on centers and within 12" of every associated cabinet, box or fitting.
- 9 Installation of raceways, boxes and cabinets shall comply with the following general requirements:
 - (a) Covers of boxes and cabinets shall be painted red and permanently identified as to their use.
 - (b) Penetrations of fire-rated walls, floors or ceilings shall be fire stopped.
 - (c) Within stairways, raceways within 8 feet of the floor shall not be installed so as to reduce or obstruct the stairway radius.
 - (d) Raceways or cables shall not penetrate top of any equipment box or cabinet.
10. All conduits supplying 120-volt power to the fire alarm control unit and/or to outlying control cabinets, shall contain a green insulated grounding conductor sized in accordance with the New York City Electrical Code (#10 AWG minimum). The grounding conductor shall be connected to the ground bus or other suitable grounding terminal in each box and cabinet in which it enters. At the fuse cutout panel supplying the fire alarm system, provide a grounding electrode

conductor sized and installed in accordance with the New York City Electrical Code (#10 AWG minimum).

*12. For cabinets whose 120 volt supply is not derived from the main fire alarm system cutout panel, provide green insulated separate grounding electrode conductors, sized and installed as per New York City Electrical Code (#10 AWG minimum). In steel-framed buildings, a connection to local steel structure will be acceptable.

***"12." enacted but "11" probably intended.**

12. Splices and terminations of wires and cables shall be as follows:

(a) Permitted only in boxes or cabinets specifically approved for the purpose.

(b) Utilize mechanical connections specifically approved by U.L.486 A & C for the conductors, or if soldered, first joined so as to be mechanically and electrically secure prior to soldering and insulating. Temperature rating of completed splices shall equal or exceed the temperature rating of the highest rated conductor.

13. Wiring for audible and visual alarm notification devices shall be arranged so that a loss of a portion of the wiring on a floor will not render more than 60% of the devices of each type inoperative, and the devices shall be so connected to the circuitry (i.e. by means of alternate circuits) as to maintain at least partial audibility/visibility throughout the entire floor.

(v) The equipment shall be colored RED and enclosed in suitable housing permanently fastened to the structure at the appropriate locations. A diagonal white stripe one inch wide from upper left corner to lower right corner shall be painted or applied to sending stations. The stripe shall not render any lettering illegible or obliterate the station number.

(vi) The name and telephone number of the central office company shall be displayed at all manual pull stations and at all central office transmitters.

(vii) There shall be a fire guard on duty at all times that the Place of Assembly is open and functioning as a cabaret. The fire guard shall have a Certificate of Fitness issued by the New York City Fire Department.

(viii) Emergency Lighting and Sprinkler Systems shall be installed and maintained as required by law.

(ix) A Fire Alarm System in a Place of Assembly subject to this rule in a high rise (Class E) office building shall interface with Fire Alarm and Communication System required by Local Law No. 5/1973.

(x) Applications shall be filed and permits obtained as required by Departmental Memorandum.

§15-03 [Repealed]

§15-04 Exemption of Certain Existing J-1 Residential Hotels from Certain Fire Safety Special Filing Requirements.

(a) *Definition.* Existing J-1 Residential Hotel. An existing J-1 residential hotel is defined as a single room occupancy multiple dwelling, in which at least seventy-five (75) percent or more of the total number of occupied individual dwelling units:

- (1) have had no more than two (2) separate tenancies for at least three (3) years preceding the date on which the application for residential hotel status is made or, preceding the date of submission of an annual certification as set forth below or
- (2) have been used by a religious not-for-profit organization

Rules and Regulations

as a residency for its members who maintain residency for at least (1) year and have no more than two (2) separate tenancies for at least (1) year preceding the date on which the application for residential hotel status is made, provided that a fire safety plan for fire drill and evacuation procedures in accordance with the requirements of the Fire Commissioner shall be submitted to the Fire Department and the approval of the Fire Commissioner shall be obtained.

(b) *Details of exemptions.* This section shall exempt owners of existing "residential hotels", as that term is defined in §15-04(a), from J-1 fire safety special filing requirements of §§27-382(b), 27-384(b), 27-954(w), 27-989(b), 27-996.2(a)(2) of Article 26 of Subchapter 1 of Chapter 1 of Title 27 of the Administrative (Building) Code as enacted by Local Law 16 of 1984, effective March 17, 1984, as well as installation requirements set forth in the following sections:

- (1) §27-382 (b) Power source-Exit lights.
- (2) §27-384 (b) Power source-Exit signs.
- (3) §27-954 (w) Required sprinklers.
- (4) §27-989 (b) Elevator in readiness.
- (5) §27-996.2 (a) (2) Firemen service operation in existing elevators.

(c) *Certification.*

(1) The certification of residential hotel status may be obtained only by the filing of an alteration application for residential hotel certification. Such application shall contain the supporting documentation required in §15-04(d) below. Certification of residential hotel status as defined in § [sic] 15-03(a) [sic] above shall be issued by the borough superintendent. Certification shall be valid for a period of one (1) year from the date of initial certification. Thereafter, the owner of the residential hotel shall engage a registered architect or licensed professional engineer to certify annually through the filing of a building notice application that the residential hotel is in compliance with the requirements of § [sic] 15-03(a) [sic] above.

(2) Owners of residential hotels shall keep a copy of their residential hotel certification on site at the hotel. Failure to timely renew a hotel's residential certification may result in the issuance of violations for the hotel's failure to comply with the requirements of Local Law 16 of 1984 and Local Law 16 of 1987 for a J-1 occupancy.

(d) *Supporting Documentation.* The following documentation shall be furnished by the owner in support of his or her application for certification of residential hotel status:

- (1) Certificate of Occupancy or, if unavailable;
- (2) Occupancy and Arrangement Card from the Department of Housing Preservation and Development and Department of Housing Preservation and Development Computer Printout;
- (3) List all rooms occupied by tenants who have resided at the premises for six months or longer or who are in occupancy pursuant to a lease of six months or longer, together with the name of the tenant in each of the aforementioned rooms and copies of any and all existing leases for the period stated in § [sic] 15-03(a) [sic] of this section; and
- (4) For each dwelling unit in the premises subject to rent control or hotel stabilization, copies of the annual registration statement filed with the New York State Division of Housing and Community Renewal; and
- (5) Copies of any relevant documents filed by the owner with the Hotel Stabilization Association; and

(6) Any other documentation deemed relevant by the borough superintendent, in his or her discretion.

(e) *Determination of J-2 Dormitory.*

(1) A building owner may contend that his/her building is a dormitory and therefore as a J-2 occupancy need only provide stair and elevator signs, and if a high-rise building also remove locks on elevator and hoistway doors. To qualify as a dormitory, the building's current Certificate of Occupancy must indicate use as a dormitory. Where the Certificate of Occupancy indicates both dormitory and J-1 occupancy, those portions which are J-1 must comply with LL 16/84 requirements for J-1 occupancies.

(2) When an owner seeks to amend his building's Certificate of Occupancy [sic] to provide for dormitory occupancy, he must submit an affidavit stating he will use the dormitory space only for sleeping accommodations of individuals on a month-to-month or longer-term basis (Adm. Code §27-265) and that the dormitory will be owned and operated by either a not-for-profit corporation or a school. Such amended Certificates of Occupancy shall provide that the dormitory may only be owned or operated by either a not-for-profit corporation or a school.

§15-05 Filing and Approval of a Fire Safety Plan for Buildings Containing Transient Occupants Such as Hotels and Motels.

(a) *Number of occupants.*

These rules and regulations shall apply to buildings or parts thereof classified in Article 11 of Subchapter 3 of Chapter 1 of [sic] Title 27 of the Administrative Code of the City of New York as occupancy group J-1, J-2 occupied or arranged to be occupied in whole or part by a transient occupancy. For the purpose of these rules and regulations, buildings or parts thereof which contain a total of more than 30 sleeping rooms or can accommodate a total of more than 30 lodgers, or contains more than 15 sleeping rooms, or can accommodate more than 15 lodgers above the first or ground story, used for living or sleeping purposes by the same person or persons for a period of ninety days or less shall be considered as being occupied by a transient occupancy. Such buildings shall include but are not limited to buildings occupied as hotels, motels, lodging houses, dormitories and single room occupancies. All such buildings occupied or arranged to be occupied in whole or part by a transient occupancy, regardless of the number of sleeping rooms or accommodations, over 75 feet in height, shall comply with these rules and regulations. The owner or other person having charge of such building shall file a Fire Safety Plan with the Fire Department indicating compliance with §15-05(b) within 30 days after the effective date of these rules and regulations. The owner or other person shall resubmit the revised Fire Safety Plan for approval within 30 days after receiving comments from the Fire Department. Upon approval, the Fire Safety Plan shall be immediately put into effect. The owner or other person having charge of such building shall comply with §§15-05(c)(1) to 15-04(c)(5) within 30 days of the effective date of these rules & regulations.

b) *Details of fire safety plan.*

(1) A fire safety plan for fire drill and evacuation procedures in accordance with the requirements of the Fire Commissioner shall be submitted to the Fire Department and the approval of the Fire Commissioner shall be obtained. The applicable parts of the fire safety plan shall be distributed to the building service employees. All employees of the building shall participate and

Rules and Regulations

cooperate in carrying out the provisions of the fire safety plan.

(2) *Fire safety director and deputy fire safety director.*

(i) One employee shall be designated as fire safety director and a sufficient number of employees shall be designated as deputy fire safety directors. Such employees shall have a knowledge of the building's fire protection systems and shall have a certificate of fitness, in accordance with the requirements of the Fire Commissioner, qualifying him to conduct fire drills, evacuations and related activities such as organizing, training and supervising a fire brigade when required. In the absence of a fire safety director, when a fire safety director is required to be on duty in the building, such deputy fire safety director shall act as fire safety director.

(ii) As the building is continuously occupied, there shall be a fire safety director continuously on duty in the building with the required certificate of fitness. During fire emergencies, the primary responsibility of the fire safety director shall be the manning of the fire command post and the direction and execution of the evacuation as provided in the fire safety plan and to assist the Fire Department with his knowledge of the building's fire protection systems. Such activities shall be subject to the Fire Department control.

(3) If sufficient personnel are available, as determined by the Fire Department, a fire brigade shall be organized.

(4) Fire drills shall be conducted, in accordance with the fire safety plan, at least once every three months on each shift. A written record of such drills shall be kept on the premises for a three year period and shall be readily available for inspection by the Fire Department.

(5) In buildings where compliance would cause practical difficulty or undue hardship, the Fire Commissioner may waive or modify the requirements of this subdivision and accept alternatives fulfilling the intent of these requirements consistent with public safety.

(c) *Signage.*

(1) *Elevator landings.* A sign shall be posted and maintained on every floor at the elevator landing. The sign shall read "IN CASE OF FIRE, USE STAIRS UNLESS OTHERWISE INSTRUCTED". The lettering shall be at least one-half inch block letters and of contrasting color from the background or as otherwise approved by the Commissioner of Buildings. Such lettering shall be properly spaced to provide good legibility. The sign shall also contain a diagram showing the location where it is posted and the location and letter identification of the stairs on the floor. The sign shall be at least eight inches by ten inches, located directly above a call button and securely attached to the wall or partition. The top of such sign shall not be above six feet from the floor level. The diagram on such sign may be omitted provided that signs containing such diagram are posted in conspicuous places on the respective floor. In such case, the sign at the elevator landing shall be at least two and one half inches by ten inches and the diagram signs shall be at least eight inches by ten inches.

(2) *Floor numbering.*

A sign shall be posted and maintained with each stair enclosure on every floor, indicating the number of the floor. The numerals and background shall be in contrasting colors. The sign shall be securely attached to the stair side of the door.

(3) *Stair and elevators.*

Each stair and each bank of elevators shall be identified by an

alphabetic letter. A sign indicating the letter of identification for the elevator bank shall be posted and maintained at each elevator landing directly above or as part of the sign specified in §15-05(c)(1). The stair identification sign shall be posted and maintained on the occupancy side of the stair door. The letter on the sign shall be at least three inches high, of bold type and of contrasting color from the background. Such signs shall be securely attached.

(4) *Sign material.* Signs shall be of metal or other durable material.

(5) *Placing, size and content of signs.* A sign shall be posted and maintained on the inside of every door opening onto a public corridor giving access to a sleeping room. The sign shall contain a diagram showing the location where it is posted and the location and letter identification of the exit stairs on the floor. The diagram shall indicate the number of doors opening onto the public corridor which must be passed to reach each exit stair. The sign shall be at least eight inches by ten inches, located on the inside of the door and securely attached thereto. The top of such signs shall not be above six feet from the floor level. These signs are in addition to the signs required in §15-05(c)(1). These signs may contain such additional information as the Fire Department may require.

(6) *Additional sign requirements.* When floors or parts of floors are used as accessory to a J-1 and J-2 transient occupancy, "Elevator Landings" §15-05(c)(1), "Floor Numbering" §15-05(c)(2) and "Stairs and Elevators" §15-05(c)(3), shall be required.

§15-06 Design of Composite Construction with Metal Decks or Lightweight Concrete.

(a) Metal deck construction is to be approved strictly in accordance with Board of Standards and Appeals or MEA approval in all respects, with no interchangeability or equivalent materials authorized except as noted in these rules.

(b) When metal decks have been approved for use where a fire resistive floor or roof is required, equivalent materials may be authorized or interchanged for any of the components of the assembly by borough superintendents pursuant to §27-107 of the Administrative Code based on; [sic]

(1) Similar full scale tests conforming with A.S.T.M. E119-1988; or,

(2) A combination of small scale and/or half scale tests and engineering evaluation acceptable to the commissioner in conjunction with evaluation of full scale tests conforming with ASTM E119-1988 for a variety of assemblies of combination of materials, or

(3) A combination of small scale, half scale or full size tests representative of the actual fire exposure of the occupancy and engineering evaluations, all acceptable to the commissioner.

(c) When metal decks have been approved for use where a fire resistive floor or roof is required without any fire protection below the metal deck, they shall not be authorized in connection with composite beam design unless the approval specifies that the decks have been tested in accordance with both floor and beam requirements; or, alternately, fire protection is applied below the metal deck having the same thickness as that applied to the beam, for that width of slab acting as part of the composite beam, except that no such fire protection need be applied below the metal deck when the floor or roof slab and deck have a fire resistive rating at least equal to that of the

Rules and Regulations

supporting beams, etc of the concrete fill-in is equal to or greater than 3000 p.s.i..

(d) Where the structural design is in accordance with load tests referred to in a board approval, the load carrying capacity can be accepted provided that design criteria for all structural elements are specified in the resolution of the board. Where the approval of the board simply makes general reference to other criteria, the following structural guidelines are to be adhered to, with respect to composite construction:

(1) Concrete in the ribs of metal decks is to be completely excluded in flexural computations, in the composite T-beam design. However, it may be included for bond calculations (which is to be based on allowable stresses of 20 p.s.i.) as well as shear stresses for slab action exclusively.

(2) Slab designs shall be required to comply with all applicable requirements of Reference Standards RS 10-3, and RS 10-5A with structural calculations submitted in all cases in regard to n ratios (see §1102(b) of RS 10-3), fiber [sic] stresses, shear stresses, bond stresses, length-deep and/or deflection limitations, and shear connection loads.

(3) The capacity of shear connectors in lightweight concrete shall only be rated at 80 percent of the values specified in Table 1.11.4 of Reference Standard RS 10-5 for normal weight aggregate. When metal decks with ribs not exceeding 1 and 1/2 inches in depth are used, the capacity of the shear connectors is to be further reduced by 15 percent, so as to have a total rated capacity of 65 percent of the values stated in Table 1.11.4 when lightweight concrete is used in composite construction with metal decks, and 85 percent when normal aggregate is used in such construction, unless prequalified load tests pursuant to §27-599 warrant higher values. Shear connectors not listed in Table 1.11.4, or differing on length or size may not be used without specific Board Approval for specific loads.

(4) When metal decks having ribs exceeding 1 and 1/2 inches in height are employed with composite construction, prequalified load tests of the slab and beam, pursuant to §27-599, shall be required before any approval is granted.

(5) All welding on [sic] shear connectors shall be performed by licensed welders, except as otherwise authorized in an intradepartmental memorandum dated June 6, 1967.

§15-07 Fire-Retarding of Entrance Halls, Stair Halls and Public Halls in Old Law Tenements and Converted Dwellings.

(a) *Intent.* The fire-retarding rules herewith set forth are approved by the Department of Buildings for old law tenements and converted dwellings where their entrance halls, stair halls and public halls are required, by §189, subdivisions 1 and 4, §238, subdivision 4, and §218, subdivisions 5 and 6, Multiple Dwelling Law, and by §27-2044, Housing Maintenance Code, to be fire-retarded in a manner approved by the Department of Buildings.

(1) All entrance halls, stair halls and public halls, including service halls and stairs, shall be fire retarded to the extent required by the Multiple Dwelling Law and the Housing Maintenance Code.

(2) It is the intent that all wood structural members of partitions, ceilings and stair soffits shall be completely protected with fire-retarding materials where they may be exposed to fire in entrance, stair and public halls. To this extent these rules and regulations cover only general conditions and are not designed to cover specific or special cases. Where such may occur the owner

is required to consult the Department of Buildings and receive instructions before work is started.

(3) Where existing dumbwaiter shafts are located in, or open on public halls which are required to be fire-retarded, such dumbwaiter shafts, when not constructed of fireproof or fire-retarding materials, shall be fire-retarded on the inner side, from the lowest story to the roof inclusive, in accordance with the requirements of §15-07(b)(1) or (b)(2), except in cellar where such shafts shall be enclosed with fireproof materials.

All doors opening from such dumbwaiter shafts shall be self-closing, and doors and assemblies when of wood or other non-fireproof construction shall be lined on both sides with No. 26 U.S. gage [sic] metal, except in cellar where doors and assemblies shall have a fire-resistive rating [sic] of at least one (1) hour.

(4) It is not intended that these rules and regulations in themselves require plans to be filed. However, should any work involve structural changes, then plans are required to be filed in the Department of Buildings and such changes shall be subject to all other rules and regulations applicable thereto.

(5) Work shall not commence until satisfactory evidence has been submitted to the Department of Buildings that compensation insurance has been obtained in accordance with the provisions of the Workmen's Compensation Law.

It is the intent of §238, subdivision 4, Multiple Dwelling Law, that every entrance hall, public hall and stair hall in every old law tenement four stories or more in height shall be fire-retarded.

Every old law tenement three stories and a basement, or three stories, basement and cellar in height shall be deemed to be four stories when the main entrance from the grade is to the basement, and every entrance hall, public hall and stair hall in such building shall be fire-retarded.

In old law tenements where the entrance halls, public halls and stair halls are required to be fire-retarded, existing wood stairs shall be fire-retarded in conformity with the requirements of these rules and regulations, whether or not such halls had been fire-retarded in accordance with plans filed with and approved by the former Tenement House Department or Department of Buildings, prior to the enactment of subdivision 4 of §238 of the Multiple Dwelling Law.

(b) *Partitions.* All existing partitions separating apartments from entrance halls, stair halls and public halls, or otherwise forming enclosing partitions of entrance halls, stair halls and public halls, shall be fire-retarded by any one of the following methods:

(1) *Metal lath and cement of gypsum mortar.* Completely remove all existing materials to face of studs or other structural members on hall side of partitions and recover with metal lath and two coats of cement or [sic] gypsum mortar. If cement mortar is used it shall be three-quarters inch (3/4") thick, if gypsum mortar is used it shall be one inch (1") thick. The second coat of mortar shall not be applied until the first coat has thoroughly set and in no case shall the second coat be applied on the same day that the first coat of mortar is applied. In lieu of the above method, completely remove all combustible materials from plaster face of partitions on hall side and repair existing plaster. After inspection, cover existing plaster with herringbone or similar approved type metal lath with rigid rib reinforcement to provide good bond between new and existing

Rules and Regulations

plaster. Cover lath with two coats (scratch and brown) of cement or [*sic*] gypsum mortar as above.

The first coat of cement mortar (scratch) shall be composed of one (1) part of Portland cement to one and one-half (1 1/2) parts of sand, with additional volume of hydrated lime not greater than ten (10) percent of the volume of Portland cement. The second coat (brown) shall be composed of one (1) part of Portland cement to three (3) parts of sand, with additional volume of hydrated lime not greater than ten (10) percent of the volume of Portland cement.

The first coat (scratch) of gypsum mortar shall be composed of one (1) part of gypsum to one (1) part of sand. The second coat (brown) of gypsum mortar shall be composed of one (1) part of gypsum to one and one-half (1 1/2) parts of sand.

(2) *Plaster boards and gypsum mortar or stamped metal.* Completely remove all existing materials to face of studs or other structural members on hall side of partitions and recover with plaster boards or perforated rock lath three-eighths inch (3/8") thick, covered with two coats of gypsum mortar (scratch and brown) so that the aggregate thickness shall be at least one inch (1"), or in lieu thereof, recover same with plaster boards one-half inch (1/2") thick, covered with No. 26 U.S. gage [*sic*] stamped metal.

In lieu of the above method, completely remove all combustible material from plaster face of partitions on hall side and repair existing plaster. After inspection, plaster boards or perforated rock lath may be applied directly over the existing plaster face of partitions on hall side. Cover plaster boards or perforated rock lath with two coats of gypsum mortar as above, or plaster boards may be covered with No. 26 U.S. gage [*sic*] stamped metal.

(3) *Mineral wool.* Fill solidly between partition uprights, from underside of flooring to ceiling with mineral wool blown in place by the pneumatic method, packed solidly to fill all spaces and voids.

(4) *Brick, gypsum, etc.* Fill solidly between partition uprights from underside of flooring to ceiling with brick, gypsum, or other acceptable material packed solidly to fill all spaces and voids. Where brick, gypsum, or other masonry material is intended to be used, application must be filed before installation with the Department of Buildings for approval of strength of existing members intended to support the proposed masonry fire-retarding.

(5) *Other methods.* No other method may be used unless same is acceptable to the Department of Housing and Buildings.

(6) *Removal of windows in public hall partitions.* When windows in walls or partitions are removed, both sides of the openings shall be sealed with fire-retarding materials, except that wood lath and plaster may be used on the room side of the opening when the existing surface of the room is constructed of wood lath and plaster.

(7) *Electric meters.* Where direct current (DC) electric meters of public utility companies are present or installed on partitions of public halls the fire-retarding shall continue unbroken behind the meters or the meters shall be mounted on a heavy slate back or non-magnetic fireproof equivalent, such as transite, asbestos board, etc., against which fire-retarding finished up tightly.

(8) *Partitions in Class B converted dwellings.* Where fire-retarding is required in any Class B converted dwelling referred to in §15-07(a)(7), both sides of all enclosure partitions of

entrance halls, stair halls and public halls throughout such building shall be fire-retarded in accordance with the method set forth in §§15-07(b)(1) or (b)(2) or said partitions shall be fire-retarded in accordance with the provisions of §§15-07(b)(3) or (b)(4).

(9) *Partitions in altered old law tenements.* In any old law tenement where the occupancy is increased on any story, the enclosing partitions of any entrance hall, stair hall or public hall on the story where the occupancy has been increased, shall be fire-retarded on both sides. Such requirements shall apply only to the walls of the entrance hall, stair hall or public hall adjoining the altered apartment. The enclosing partitions of such halls other than those adjoining the altered apartment and the partitions on any story where the occupancy has not been increased, shall be fire-retarded on the hall side. The method of fire-retarding shall be as set forth in §§15-07(b)(1) or (b)(2), or said partitions shall be fire-retarded in accordance with the provisions of §§15-07(b)(3) or (b)(4).

(10) *Newly constructed partitions.* In any entrance hall, stair hall or public hall where any partition or part thereof is newly constructed, and where the plaster has been removed from any partition or part thereof, such partition shall be fire-retarded on both sides.

(c) *Ceilings.* Any approved method for fire-retarding partitions shall be acceptable for fire-retarding ceilings, provided that all existing materials are completely removed to face of joists. Mineral wool, brick gypsum or other masonry fill will not be accepted.

(1) Where any entrance hall, public hall or stair hall, or any portion thereof, in any part of any old law tenement or [*sic*] converted dwelling is required to be fire-retarded that portion of any ceiling directly underneath any such entrance hall, public hall or stair hall shall be fire-retarded. Where such ceiling is located in any store, apartment or other space it shall also be fire-retarded as required for partitions by §§15-07(b)(1) or (b)(2).

Where the above method is impractical due to the existing ceiling construction in any such store, apartment or other space, the Department of Buildings may permit the fire-retarding of such ceilings to be applied from above by removing the floor of any such entrance hall, public hall or stair hall and installing between the floor beams, and directly against ceiling below, a layer of heavy building paper over which there shall be placed a basket made of reinforced ribbed expanded metal lath weighing at least 3.4 pounds per square yard. Such basket shall be lined with Portland cement or gypsum mortar not less than one inch (1") in thickness. The building paper, metal lath and cement or gypsum mortar shall be carried at least halfway up on the side of beams. However, this method will not be accepted for the fire-retarding of any such ceiling located in a space used for a hazardous purpose or business, nor will it be accepted for fire-retarding of any such ceiling located in the cellar or for the fire-retarding of any ceiling located in any store, apartment or other space when such ceiling is constructed of wood or of wood and metal applied directly to the beams. In such cases the ceilings shall be fire-retarded according to the requirements of §§15-07(b)(1) or (b)(2).

(d) *Existing wood stairs.* Except where stairs of incombustible material are required in Class B converted dwellings as set forth in §15-07(a)(7), all wood railings, balustrades and newel

Rules and Regulations

posts shall be completely removed from every existing wood stairs and such stairs shall be provided with railings, balustrades and newel posts of metal or other hard incombustible material, of such size and secured in such manner to the existing stairs as may be approved by the Department of Buildings, except handrails may be of hardwood.

Soffits and stringers of existing wood stairs shall be fire-retarded in accordance with the methods set forth in §§15-07(e) or (f).

(e) *Stair soffits.* The soffits of every stair in every entrance hall, public hall and stair hall, including any soffit extending beyond the enclosure partitions of any such hall, shall be fire-retarded.

Any approved method for fire-retarding partitions shall be acceptable for fire-retarding stair soffits provided that all existing materials are completely removed to face of structural members of stair soffits.

(f) *Fascia-stair and well.* Fascia of outside stringer on rake of stairs, and well fascia at floor level, shall be fire-retarded their full depth to form complete seals with the soffits of stairs and ceilings of halls, respectively. Type of fire-retarding shall be one of those herein approved for ceilings of halls, or in lieu thereof, cover fascia with sheet asbestos not less than three-sixteenths inch (3/16") thick with joints well pointed over which there shall be an additional single layer of No. 26 U.S. gage [sic] stamped metal or cover fascia with a single layer of No. 14 U.S. gage [sic] steel.

(g) *Fire-stopping.* All partitions required to be fire-retarded shall be fire-stopped with incombustible material at floors, ceilings and roofs. Fire-stopping over partitions shall extend from the ceilings to the underside of the flooring or roofing above. Fire-stopping under partitions shall extend from the underside of flooring to ceiling below. All [sic] spaces between floor joints (directly over and under partitions) shall be completely filled the full depth of joists. Any space from top of partition to underside of roof boarding shall be completely fire-stopped.

Fire-stopping shall be done with brick, cinder concrete, gypsum, metal lath and Portland cement or gypsum mortar, mineral wool, or other materials acceptable to the Department of Buildings.

(h) *Door openings.* Except as provided in §§15-07(h)(1) and (h)(2), all door openings into any public hall, entrance hall or stair hall which is required to be fire-retarded shall be equipped with self-closing protective assemblies having a fire-resistive rating of at least one hour.

(1) In old law tenements where the number of apartments is not being increased, existing wood doors opening into public halls, entrance halls or stair halls may remain provided such doors are made to be self-closing ("Butterfly" spring hinges are not acceptable) and, provided further, all glazed transoms and panels in every such door are glazed with wire glass. All such transoms shall be made stationary.

(2) Where, in any old law tenement, the number of apartments is being increased on one or more stories, door openings into public halls, entrance halls or stair halls on each story or stories shall be equipped with self-closing protective assemblies having a fire-resistive rating of at least one hour.

In such old law tenements existing wood doors opening into public halls, entrance halls or stair halls may remain on any story where there is no increase in the number of apartments, provided such doors and every transom and panel in same are made to conform to the requirements set forth in §15-07(h).

(3) All doors shall be properly fitted to their assemblies and there shall be no unnecessary space between doors and door bucks or saddles.

(i) *Materials.* All materials used in the process of fire-retarding shall be of a type and manufacture acceptable to the Department of Buildings.

The following shall be considered as minimum requirements:

(1) *Metal lath.* Metal lath shall weigh at least 30 pounds per square yard, except lath used over existing plaster which lath shall weigh at least 3.4 pounds per square yard and be reinforced with rigid ribs not less than three eighths inch (3/8") deep, spaced not more than eight inches (8") on center running full length of sheets. Where ribs exceed 4.8 inches on center, same shall have at least one intermediate one eighth inch (1/8") inverted rib running the full length of sheets.

Metal lath fastened to studs [sic] shall be attached at least six inch (6") [sic] intervals with 4-penny nails or one inch (1") roofing nails or No. 14 steel wire gage [sic] wire staples, and to wood joists by at least 6-penny nails, one and one-quarter inch (1 1/4") roofing nails, or one inch (1") No. 14 steel wire gage [sic] wire staples. When metal lath is applied over existing plastered surfaces, same shall be fastened with nails or staples of the same gage [sic] and such nails or staples shall have anchorage of at least one-half inch (1/2") in studs and three-quarters inch (3/4") in joists. Laps between the studs or joists shall be securely tied or laced. Stiffened metal lath on wood studs, or joists, shall be nailed or stapled at least at eight inch (8") intervals, and the laps between studs similarly tied or laced. Metal lath shall be galvanized or painted.

(2) *Plaster boards or perforated rock lath.* Plaster boards or perforated rock lath shall be of type and manufacture acceptable to the Department of Buildings. Each board shall bear the name of manufacturer [sic] and brand stamped thereon for inspection after erection.

Plaster boards or perforated rock lath nailed directly to wood studding or joists shall be fastened with one and one-eighth inches (1 1/8") wire nails of at least No. 13 steel wire gage [sic] with flat three-eighth inch (3/8") heads. When such boards are applied over existing plastered surfaces, same shall be fastened with nails of the same gage [sic] and such nails shall have anchorage of at least one-half inch (1/2") in studs and three-quarters inch (3/4") in joists. The maximum space between nails shall be four inches (4"). The joints shall be broken at every other board. The wetting of such boards before plastering is forbidden.

(3) *Stamped metal.* Stamped metal shall be No. 26 U.S. gage [sic] (equivalent thickness .018 inches or 3/160 inches) with one inch (1") lapped seams. Size of sheets shall be not more than twenty-four inches by ninety-six inches (24" x 96"), having a selvage consisting of a half-round bead sufficient to create a one inch (1") overlap at both seams. Nailing shall be secured direct to studs or joists with 6-penny smooth box nails (two inches (2") or No. 12 1/2 gage [sic]) with nails on end seams spaced not more than three inches (3") apart. Nailing to plaster is forbidden and in all cases nails shall have anchorage of at least one-half inch (1/2") in studs and three-quarters inch (3/4") in joists. All beads at seams shall be chisel sealed, making a tight joint. All sheets shall be marked "26 U.S. Gage" [sic] for identification and inspection after erection.

(4) *Mineral wool.* Mineral wool shall be of a type and

Rules and Regulations

manufacture acceptable to the Department of Buildings.

Holes shall be cut approximately three inches (3") in diameter through the wood lath and plaster near the ceiling, in the panels between each two adjacent studs. As an alternative, holes may be cut approximately three inches by six inches (3" x 6") on every second stud. Check each stud panel with weight and line to find out whether there is any obstruction. If any cross-bridging or other obstruction is encountered additional holes shall be cut until access has been gained to all open spaces within the stud panel in all specified partitions. Mineral wool shall then be blown into all spaces by the pneumatic method with air pressure sufficient to pack the insulation to a density acceptable to the Department of Buildings. Mineral wool for this work shall be in bags or containers marked with manufacturer's name and label specifying its type.

(5) *Other materials.* No other material may be used unless same is acceptable to the Department of Buildings.

(j) *Exceptions.* Where any portion of any entrance hall, stair hall or public hall has been previously fire-retarded under the supervision of this department, the former Tenement House Department or various former Department of Buildings, such fire-retarding will be accepted only to the extent that same has been previously approved, provided, however, that such entrance hall, stair hall or public hall is otherwise made to conform to all the requirements set forth in these rules.

§15-08 Fire-Retarding of Cellar Ceilings in Old Law Tenements and Converted Dwellings.

(a) *Intent.* The fire-retarding rules herewith set forth are approved by the Department of Buildings for the existing multiple dwellings where the ceilings of the cellar or other lowest story is required, by §85 and §240, subdivision 3, Multiple Dwelling Law, and by §27-2044, Housing Maintenance Code, to be fire-retarded in a manner approved by the Department of Buildings.

(1) It is the intent of the law to provide a continuous fire-retarded covering over the entire ceiling of the cellar, or other lowest story, so as to prevent fire communicating with upper stories of a multiple dwelling.

Where there is a space less than four feet six inches (4'-6") in height from the ground or floor level to the underside of the first tier of beams, such space shall be considered as an "air space" and not as a cellar. However, when such space opens to a cellar where fire-retarding of the ceiling is required, then such space shall be separated from the cellar with a partition constructed of incombustible material in which there is provided self-closing door and assembly having a fire-resistive rating of at least one hour.

Where the ceiling of the cellar or other lowest story is required to be fire-retarded, all openings in such ceilings for stairways not located directly under a main stair, also openings in ceiling such as pipe shafts, vent shafts, unenclosed dumbwaiter shafts, disused flues, etc., shall be properly closed. (Private stairs within duplex apartments extending into cellar or basement are not required to be enclosed.)

New partitions erected to enclose existing stair referred to in the preceding paragraph shall be of incombustible materials. Existing partitions enclosing any such stair will be acceptable where same are of incombustible materials or where same are fire-retarded on both sides in accordance with the methods set

forth in §15-07(b)(1) or (b)(2) and with materials conforming with the requirements of §15-07(i) of these rules and regulations. Door openings in such enclosure partitions shall be equipped with self-closing protective assemblies having fire-resistive ratings of at least one hour.

When existing shafts, including dumbwaiter shafts, extend below the ceiling a distance less than one-half (1/2) the height of the cellar, such shafts shall be considered as being part of the cellar ceiling and the enclosures of said shafts shall be fire-retarded in the same manner as required for cellar ceilings. All existing shafts, including dumbwaiter shafts, which extend below the ceiling a distance more than one-half (1/2) the height of the cellar shall be enclosed with incombustible materials. All shafts referred to in this paragraph shall have adequate cleanout at base consisting of fireproof [*sic*] self-closing door and assembly having a fire-rating of at least one hour.

Where new partitions or enclosures are erected in a cellar they shall be constructed of incombustible materials.

(2) *Wood girders, columns, posts, etc.* The fire-retarding material of ceiling of cellar or other lowest story shall be carried down and around all non-fireproof ceiling projections, such as wood girders, etc., which are less than six inches by six inches (6" x 6") in dimension.

The fire-retarding material also shall be turned down at least three inches (3") on all non-fire-retarding columns, posts, etc., which are less than six inches (6") in diameter.

(3) *Non-fire-retarded cellar partitions.* When non-fire-retarded partitions in cellar, or other lowest story, extend to the ceiling, the fire-retarding material of the ceiling shall be turned down at least three inches (3") on said partitions, or the partitions shall be cut off at top to permit the fire-retarding of the ceiling to be continuous.

Where, in any old law tenement three (3) stories and basement in height, there is also a cellar under the basement story, the ceiling of such cellar shall be fire-retarded; and also, in any such old law tenement, where the main entrance from the grade is to the first story that portion of the basement ceiling which is directly under the first story entrance hall, public hall and stair hall shall be fire-retarded.

In every old law tenement three (3) stories and basement in height with no cellar under the basement, where the main entrance from the grade is to the basement story, the ceiling of the basement story shall be fire-retarded throughout. In any such old law tenement where the main entrance from the grade is to the first story no such fire-retarding will be required.

(4) *Heating appliances.* The portion of the ceiling over any furnace, boiler or hot water heater shall be fire-retarded in accordance with the methods set forth in §§15-07(b)(1) or (b)(2), and such fire-retarding shall extend for a distance of at least four feet (4'-0") beyond the sides and rear, and eight feet (8'-0") in front of such furnace or boiler.

(5) It is not intended that these rules and regulations in themselves require plans to be filed. However, should any work involves structural changes, then plans are required to be filed in the Department of Buildings and such changes shall be subject to all other Rules and Regulations applicable thereto.

(6) Work shall not commence until satisfactory evidence has been submitted to the Department of Buildings that compensation insurance has been obtained in accordance with the provisions of the Workmen's Compensation Law.

Rules and Regulations

(b) *Methods.* Cellar ceilings shall be fire-retarded according to any of the following methods:
Metal lath and cement or gypsum mortar conforming to §15-07(b)(1) of these rules.

Plaster boards and gypsum mortar or stamped metal conforming to §15-07(b)(2) of these rules and regulations.

No. 26 U.S. gage [*sic*] stamped metal over existing plastered ceiling, when erected without damage to the plaster. Furring strips are not required, but if used, they shall be metal covered on both sides and on face surface. Stamped metal shall not be applied until after existing plastered ceiling has been inspected and approved by an inspector of the Department of Housing and Buildings.

No other method may be used unless same are acceptable to the Department of Buildings.

(c) *Materials.* Materials used shall be in accordance with the provisions of §§15-07(i)(1), (i)(2) or (i)(3) of these rules and regulations.

Mineral wool, brick, gypsum or other masonry fill will not be accepted for fire-retarding cellar ceilings.

No other materials may be used unless same are acceptable to the Department of Buildings.

§15-09 Fire-Retarding of Cooking Spaces in all Multiple Dwellings.

(a) *Intent.* The rules herewith set forth are approved by the Department of Buildings for the protection of cooking spaces under §§33 [*sic*] and 176 of the Multiple Dwelling Law.

As set forth in §33 of the Multiple Dwelling Law, nothing in these rules shall be construed as permitting fire-retarding partitions in fireproof multiple dwellings.

(b) *Multiple dwelling law.* Except when sprinkler heads are installed in conformity with subdivision (e) of this section, §33 of the Multiple Dwelling Law requires fire-retarding of cooking spaces in existing and newly constructed class A and class B multiple dwellings.

(c) *Ceilings and walls exclusive of doors.* Walls and ceilings shall be fire-retarded according to any of the following methods:

Metal lath and cement or gypsum mortar conforming to §15-07(b)(1) of these rules.

Plaster boards and gypsum mortar or stamped metal conforming to §15-07(b)(2) of these rules and regulations.

No. 26 U.S. gage [*sic*] stamped metal over existing plaster when erected without damage to the plaster. Furring strips are not required, but if used, they shall be metal covered on both sides and on face surface. Stamped metal shall not be applied until after existing plaster has been inspected and approved by an inspector of the Department of Buildings.

Materials used shall be in accordance with the provisions of §§15-07(i)(1), (i)(2) or (i)(3) of these rules and regulations.

No other methods or materials may be used unless same are acceptable to the Department of Buildings.

(d) *Combustible material.* In every cooking space, all combustible material immediately underneath or within one foot of any apparatus used for cooking or warming of food shall be fire-retarded in conformity with the applicable provisions of these rules or covered with asbestos at least three-sixteenths inch (3/16") in thickness and twenty-six gage [*sic*] metal or with fire-resistive material of equivalent rating. There shall always

be at least two feet (2'-0") of clear space above such apparatus.

(e) *Sprinkler heads installed in ceilings of cooking spaces in lieu of fire-retarding the ceilings and walls.* Where sprinkler heads are installed in the ceilings of cooking spaces in lieu of fire-retarding the ceilings and walls, all of the provisions of §§15-09(a) through (f) inclusive, shall be complied with, except that it will not be required that the fire-retarding of the walls and ceilings of cooking spaces be complied with.

Before the installation of sprinkler heads is begun an application shall be filed with and approved by the Department of Buildings.

Sprinkler heads shall be of a type and manufacture approved by the Department of Buildings or previously approved by the Board of Standards and Appeals or by the Underwriters Laboratories Limited, and shall have fusible struts constructed to fuse at a temperature not higher than two hundred twelve degrees (212°) Fahrenheit.

Every sprinkler head shall bear the year of manufacture clearly on its surface. No sprinkler head may be installed after December 31st of the year following the year of manufacture.

There shall be provided at least one (1) sprinkler head for every fifty-nine (59) square feet or fraction thereof of the floor area of the cooking space.

Sprinkler heads shall be connected with the water supply of the building through a pipe of at least one-half (1/2) inch inside diameter.

Where practicable, sprinkler heads shall be located in an upright position on top the sprinkler piping.

There shall be kept available on the premises at all times a sufficient supply of extra sprinkler heads and also a sprinkler wrench for use to replace promptly any fused or damaged sprinkler heads.

Any head which has opened or has been damaged shall be replaced immediately with a good sprinkler head.

Painting or kalsomining of sprinkler heads is prohibited.

(f) *Cooking spaces constructed after July 1, 1949.* Application and plans must be filed with and approved by the Department before any work is started in connection with the construction of any cooking space after July 1, 1949.

§15-10 Fire-Escapes, Fire Stairs and Fire Towers.

(a) *Intent.* These rules have been approved by the Department to supplement the provisions of §53 of the Multiple Dwelling Law in relation to fire-escapes, fire-stairs, etc..

Where fire-escapes serve as a means of exit from other than multiple dwellings, such fire-escapes shall comply with the laws governing such occupancy.

The voluntary erection of fire-escapes on private residence buildings or business and residence buildings shall be in conformity with these rules and regulations unless otherwise directed by the Borough Superintendent of the Department of Buildings.

It is the intent of these rules to cover only general conditions and they are not designed to cover specific or special cases. When such may occur the owner is required to consult the Department of Buildings and receive instructions before starting of work.

(1) *Fire-escapes on multiple dwellings requiring new certificate of occupancy.* Except as provided in §15-10(g)(2) re lodging houses, double-rung ladder type fire-escapes will not be accepted when a new Certificate of Occupancy is required.

(2) *Alterations for increased occupancy.* Where an alteration is made increasing occupancy on any story and a fire-escape is required such fire-escape shall conform to the provisions of

Rules and Regulations

§53 of the Multiple Dwelling Law and to the applicable provisions of these rules.

(b) *General provisions.*

(1) *Caution.* No fire-escapes shall be removed from any apartment without due precaution against leaving occupants without fire-escape protection as required by subdivision 9 of §53 of the Multiple Dwelling Law.

(2) *Entrance story, etc.-second means of egress.* Where the distance to safe landing, from the window sill of any apartment on any story, including the entrance story, is more than twelve feet (12'-0"), a balcony and sliding drop-ladder or other approved second means of egress shall be provided for such apartment. Safer egress to street or other safe place shall be provided from the termination of such means of egress.

(3) *Application blanks and plans.* Before the erection of new fire-escapes or alteration of existing fire-escapes upon any multiple dwelling, application must be filed with and approved by the Department of Buildings.

(4) *Projections beyond the building line.* Every part of fire-escapes or balconies erected on the fronts of multiple dwellings shall be at least ten feet (10') above the sidewalk when such fire-escapes or balconies project beyond the building line.

(c) *Illegal fire-escapes shall be removed.* All vertical ladder, wire, chain or cable fire-escapes if required as a means of egress shall be removed and replaced with a legal means of egress.

(d) *Acceptable existing means of egress on existing multiple dwellings.* Except as provided in §15-10(c), in any existing multiple dwelling any existing means of egress which was lawfully permitted prior to the time the Multiple Dwelling Law became effective may be continued as a legal means of egress as hereinafter enumerated.

If located on the front or rear wall of the building and properly connected with stairs with proper openings.

If located in an outer court at a point distant not more than thirty feet (30'-0") from the outer end of such court and provided such court is not less than five feet (5'-0") in width from wall to wall at any point between such fire-escape and the outer end of said court.

If located in an inner court whose least horizontal dimension is not less than fifteen feet (15'-0") measured from wall to wall.

If a party-wall balcony on the front or rear wall of the building and there are no doors or openings in the walls between the two buildings other than windows in fireproof air shafts.

If a party-balcony located in an outer court not more than fifteen feet (15'-0") in length measured from the outer end of such court to the innermost point thereof, and not less than five feet (5'-0") in width from wall to wall at any point between the fire-escape and the outer end of said court, and provided also that there are no doors or openings in the walls between the two buildings other than windows in fireproof air-shafts.

No fire-escape, however, shall be deemed sufficient unless all the following conditions are complied with:

All fire-escapes, whether a required means of egress or not, shall be maintained in good order, repair and structurally safe.

All parts shall be of iron or stone.

Except as provided in §15-10(bb) every apartment above the ground floor in each multiple dwelling shall have direct access to

a legal fire escape without passing through a public hall.

Except party-wall balconies, all balconies shall be connected to each other by means of a stair or, when permitted, by double-rung ladders.

All fire-escapes, except party-wall balconies, shall have proper drop-ladders in guides from the lowest balcony of sufficient length to reach a safe landing place beneath.

All fire-escapes not on the street shall have a safe and adequate means of egress from the yard or court to the street or to the adjoining premises.

Prompt and ready access shall be had to all fire-escapes. Except as provided in §15-10(bb), such access shall be through a living room or private hall in each apartment or suit of rooms at each story above the ground floor and shall not include the window of a stairhall, nor shall any such egress be obstructed by sinks or other kitchen fixtures, or in any other way.

No existing fire-escape shall be extended or have its location changed except with the written approval of the Department of Buildings. Where an existing apartment in a tenement house erected prior to April twelfth, nineteen hundred and one, is located entirely on a court and has no rooms opening on the street or yard, fire-escapes hereafter provided for such apartments may be located in courts under the same conditions as prescribed for existing fire-escapes in this subdivision.

When wire, chain cable or vertical ladder fire-escapes are permitted to remain on Multiple Dwellings under the provisions of subdivision 9 of §53, they shall be considered only as supplemental fire-escapes.

Such fire-escapes shall be maintained in a safe condition of repair at all times and shall be subject to the applicable requirements of all laws and to these rules in relation to maintenance of existing fire-escapes.

Before a pending violation requiring the removal of such existing fire-escapes is superseded or cancelled, an inspection shall be made in accordance with the specific requirements as set forth in the preceding paragraph.

Each of the owners of adjoining structures, commonly served by party-wall balconies serving as a required means of egress, shall maintain in good order and repair that portion of each such balcony which is on his property, and each such owner shall maintain egress normally unobstructed and unimpeded from each such balcony to and [sic] through his structure.

It shall be unlawful for the owner of a structure on which there is a party-wall balcony serving as a required means of egress from an adjoining structure, to remove such party-wall balcony or any portion thereof or to prevent, eliminate or obstruct egress from such party-wall balcony to and through his structure, unless and until such owner has had erected a legal fire-escape or other approved means of egress.

See also §15-10(bb).

(e) *Party-wall balconies.*

(1) *New party-wall balconies.* The erection of new party-wall balconies shall be subject to the discretion and jurisdiction of the Department of Buildings, provided, however, that there shall be no doors or openings in the wall between the buildings served by such balconies other than windows in fireproof airshafts. New party-wall balconies will not be permitted on adjoining frame multiple dwellings.

(2) *Existing party-wall balconies.* Party-wall balconies existing on any multiple dwelling shall afford safe egress, be kept in

Rules and Regulations

good order and repair, be constructed so as to be structurally strong and shall be maintained in conformity with all other applicable laws, rules and regulations. Such fire-escapes are acceptable on occupied multiple dwellings.

(f) *Party-wall fire-escapes.* The Department of Buildings may consent to the erection of party-wall fire-escapes on adjoining multiple dwellings, to which the occupants have safe, unobstructed access in common, when such party-wall fire-escapes are constructed and maintained in accordance with the law and these rules.

(1) Any existing party-wall fire-escape (stairways) connection with and used in common by a multiple dwelling and a non-multiple dwelling is acceptable when such fire-escape is maintained in good order and repair and affords safe egress.

(g) *Double-rung ladders.*

(1) Double-rung ladders will not be permitted on new fire-escapes.

(2) Any fire-escape existing prior to the enactment of the Multiple Dwelling Law on any multiple dwelling that does not require a certificate of occupancy resulting from an alteration, if structurally sound and in good condition and provided with existing ladders inclined at an angle not exceeding eighty (80) degrees and equipped with double-rung steps and which affords safe egress, shall be deemed to be a legal fire-escape.

When a Certification of Occupancy is requested or required in connection with a lodging house which is equipped with a double-rung ladder fire-escape and such fire-escape is in good repair and adequate, except as to type, and only minor violations exist the correction of which will make the premises conform to all other law requirements, the existing double-rung ladder fire-escape may be accepted.

(3) Except as provided in §15-10(g)(2) re lodging houses, double-rung ladders are not acceptable when a new Certificate of Occupancy is to be issued.

(h) *Alteration of existing two-balcony fire-escapes on existing multiple dwellings.* When a building is not more than three (3) stories in height and provided with a balcony on each of the second and third stories, with connecting vertical ladders, and balconies not less than two feet five inches (2'-5") in width and of adequate length, the Department of Buildings may permit the removal of vertical ladders and replacing of the said ladders with regulation sixty (60) degree connecting stairs. Standards shall be one-half inch (1/2") round or square and height of rail at least two feet nine inches (2'-9").

The stairs shall be not less than seventeen inches (17") wide with a passageway between string and wall or string and top rail of not less than fourteen inches (14"). In lieu of such passageway, the Department of Buildings will permit a drop-ladder to be installed and placed at each end of the lowest balcony in those cases where it is impractical to provide a passageway of such minimum width.

New brackets shall be provided where necessary.

The gateway shall be cut in the front rail with a drop-ladder and guides from second (2nd) story to safe landing. Where fire-escapes are located at rear of building a gooseneck ladder shall be provided. The gooseneck ladder may be placed at an angle from the top floor balcony to the roof. When placed at an angle a minimum space of twenty-four inches (24") shall be maintained between the strings and front top rail and a

minimum space of fourteen inches (14") between the strings and the front bottom rail. There shall be a space of at least twenty-four inches (24") between the string of the gooseneck ladder and the frame of the window.

Conditions may be found where this modification will not exactly apply. When such a condition is found it should be brought to the attention of the Department of Buildings for decision.

When fire-escapes are at the front no gooseneck ladder shall be required.

When access to such existing two-balcony fire-escape is solely by means of a window in a bathroom, the doors of such bathrooms shall be glazed with glass other than wire glass and all key or cylinder locks shall be removed from doors. In such bathrooms there shall be no fixtures located in front of the window opening to fire-escape.

Such altered two-balcony fire-escape shall conform to all other requirements of law and these rules and regulations.

(i) *Accessibility of fire-escapes from apartments, rooms, kitchenettes and other spaces.* Prompt and ready access shall be had to all fire-escapes and, except as provided in §15-10(bb), such access shall be through a living room, kitchenette or private hall in each apartment or suite of rooms at each story above the ground floor.

Access to fire-escapes shall not include the window of a stairhall, nor shall any such egress be obstructed by sinks or other kitchen fixtures, or in any other way.

A clear space of at least twenty-one inches (21") must be maintained as a passageway between any fixtures and the side of an opening leading to fire escapes.

In any apartment which is occupied by a "family" as defined in §4(5) Multiple Dwelling Law, and in which one or more living rooms are rented to boarders or [*sic*] lodgers, every such room shall be directly accessible to a fire-escape without passing through a public hall, and for separately occupied living rooms access to fire-escapes shall be direct from such rooms without passing through a public hall or any other separately occupied room, except as may be permitted in §§66, 67 and 248 of the Multiple Dwelling Law.

(1) *Egress from apartments used for "Single Room Occupancy".* No room in any apartment shall be so occupied for "single room occupancy" unless each room therein shall have free and unobstructed access to each required means of egress from the dwelling without passing through any sleeping room, bathroom or water-closet compartment.

In apartments used for "single room occupancy" there shall be access to a second means of egress within the apartment without passing through any public stair or public hall. On and after July 1, 1957, every tenement used or occupied for single room occupancy in whole or part under the provisions of §248, Multiple Dwelling Law, and which does not have at least two means of egress accessible to each apartment and extending from the ground story to the roof, shall be provided with at least two means of egress, or, in lieu of such egress, every stair hall or public hall, and every hall or passage within an apartment, shall be equipped on each story with one or more automatic sprinkler heads approved by the department. Elevator shafts in such tenements shall be completely enclosed with fireproof or other incombustible material and the doors to such shafts shall be fireproof or shall be covered on all sides with

Rules and Regulations

incombustible material.

In apartments used for "single room occupancy" where access to a required means of egress is provided through a room such access to such room shall be through a clear opening at least thirty inches (30") wide extending from floor to ceiling and such opening shall not be equipped with any door frame, or with any device by means of which the opening may be closed, concealed or obstructed.

(j) *Window bars, gates, etc.* No iron bars, gates or other obstructing devices will be permitted on any window giving access to fire-escapes or where such window provides a secondary means of egress in case of fire on any story, including the ground floor, basement, cellar, etc.

Windows on grade level at sidewalk, yard or court, or at roof level of an adjoining building, may have bars, but at least, one window in any apartment or suite of rooms shall be without bars or obstructions of any kind in order to afford a second means of egress and such window shall conform to the provisions of §15-10(k).

(k) *Windows and doors to fire-escapes.* The window or door giving access to fire-escapes shall not be less than two feet (2') in width and the sill of the window shall not be more than three feet (3') above the floor. Window openings shall be not less than two feet six inches (2'-6") high in the clear.

(1) *Steel casement sash.* Steel casement sash opening outward onto any fire-escape balcony three feet six inches (3'-6") in width will be permitted, provided such sash is equipped with approved extension hinges so that, when opened, the sash will be flat against the wall, and further provided that there will be no adjusters on the sash as part of its equipment. Passageway of fourteen inches (14") clear width is required to be maintained between the sash or hinges and any portion of the fire-escape when the sash lies flat against the wall.

When casement sash is set at right angle to the fire-escape stairway a clear radial width of twenty inches (20") must be provided.

(2) *Wire screens and storm windows.* Wire screens are permitted on a door or window giving access to a fire-escape. Such screens may be of the rolling type, casement or of a type that slides vertically or horizontally in sections, providing that there shall be a clear unobstructed space two feet (2') in width and two feet six inches (2'-6") in height when the screens are opened and further provided that no such screen shall be subdivided with muntins or other dividing or separating bars into spaces less than two feet (2') in width by two feet six inches (2'-6") in height.

Storm sash and storm doors are permitted on openings giving access to fire-escapes provided they are arranged so as to be easily and readily opened from the inside and do not obstruct or interfere with safe egress.

(l) *Egress from fire-escape balconies not to be obstructed.* Egress from fire-escape balconies must not be obstructed by signs, fixed awnings or any other obstruction.

(m) *Extension roofs used as means of egress or directly under fire-escape balcony.*

(1) *Hereafter erected extension roofs.* Where the roof of an extension hereafter erected is to be used as a means of egress from a fire-escape, or where a fire-escape balcony is located directly above said roof, such roof shall be of fireproof construction.

(2) *Existing extension roofs.* Except in converted dwellings

where sprinklers may be installed, in every multiple dwelling where a fire-escape balcony is situated over and not more than eight feet (8') above a non-fireproof roof, or where a non-fireproof roof of an extension is to be used as egress from fire-escapes, the entire ceiling of said extension must be fire-retarded with metal lath and cement or gypsum mortar in the manner prescribed in §15-07(b)(1) and (i)(1) of these rules and regulations, or with one-half inch (1/2") approved plaster boards lined with No. 26 U.S. gage [sic] stamped metal. In buildings requiring the issuance of a Certificate of Occupancy as a result of being altered structurally, the only approved method shall be with cement or [sic] gypsum mortar and metal lath weighing not less than three (3.0) pounds per square yard which shall be applied directly to the beams or other structural members.

Where the roof of an existing extension is used as fire egress, a balcony shall be provided at the level of the roof and, if the distance between the said balcony and a safe landing is more than sixteen feet (16'-0"), a landing platform must be provided not more than ten feet (10'-0") from said safe landing and this landing platform and the balcony on the roof level must be connected by a regulation stairway. From the landing platform a drop-ladder in guides must be provided so as to reach the safe landing.

A balcony and drop-ladder in guides as per §15-10(r)(11) shall be provided for every two fire-escape stacks or fraction thereof using an extension roof for landing and fire egress.

(3) *Skylights on extensions.* Any existing skylights in said roof must be constructed of incombustible material whenever deemed necessary.

Where skylights exist or are hereafter constructed on the roof of an extension used as a means of egress from a fire-escape, they must not interfere with egress in any way and if in the line of said egress, they must be provided with a substantial guard-rail not less than three feet six inches (3'-6") high.

(n) *Egress to street required from fire-escapes located in yards and courts not extending to the street.* In an old law tenement or a converted dwelling where fire-escapes are located in a yard less than thirty feet (30'-0") in depth, or in a court which does not extend to such a yard or to the street, there shall be egress to the street by means of a fireproof [sic] passageway. In such multiple dwellings, where the yard is less than thirty feet (30'-0") in depth and where the consent of owner of the adjoining premises is obtained, in lieu of providing such fireproof [sic] passageway, a door or gate in a lot-line fence leading from such yard or court to the yard or court of the adjoining premises may be accepted, provided, however, that such door or gate provides adequate egress and is not locked or secured in any manner except by a readily [sic] accessible, easy to open hook or bolt.

Where fire-escapes are located in the yard of a new law tenement or of a multiple dwelling erected after April 18, 1929, access shall be provided from the street to the yard either in a direct line or through a court as provided in paragraph c of subdivision 2 of §238 and paragraph i of subdivision 2 of Section 27, Multiple Dwelling Law.

Where fire-escapes are located in a court of a new law tenement or of a multiple dwelling erected after April 18, 1929, and such court does not extend to the street, a fireproof passageway leading directly to the street shall be provided as required by

Rules and Regulations

paragraph b of subdivision 2 of §53, Multiple Dwelling Law. All passageways required under these Rules shall be not less than seven feet (7'-0") in height and not less than three feet (3'-0") in width and shall at all times be kept clear and unobstructed. Doors and gates at the end of such passageways are prohibited, except that a door or gate equipped with an approved-type knob or panic bolt which shall be readily openable from the inside will be permitted at the building line. Doors and gates provided with keylocks or padlocks are prohibited.

(o) *Location for new fire-escapes.* No required fire-escape shall be permitted to be placed on an adjoining property without the written consent of the Department of Buildings. No fire-escape shall be erected within ten feet (10') of the termination of a duct. Fire-escapes for existing multiple dwellings shall be located as required by the department and arranged so as to provide legal egress for all rooms and apartments.

(1) *Fire-escapes in court (side yard).* Except as provided in §15-10(bb)(6) where an apartment has a street frontage and extends also to a yard, fire-escapes may be permitted to be placed in a court (side yard) if the court (side yard) is not less than seven feet (7'-0") wide. In any multiple dwelling where exterior structural conditions are such as to prevent the erection of a fire-escape on the street front or yard, new fire-escapes may be permitted to be erected in a lot-line court (side yard) providing the lot-line court (side yard) extends from street to rear yard and is not less than three feet (3'-0") in width for its full length. Fire-escapes erected in such court may be three feet (3'-0") wide when the width of such court does not permit balconies three feet four inches (3'-4") in width.

The width of stairways and passageways and other arrangement details affected by the permitted reduction in the width of balconies will be determined and furnished to contractor by the Department upon request.

(2) Where an existing apartment in a tenement erected prior to April 12, 1901, is located entirely on a court and has no rooms opening on the street or yard, fire-escapes hereafter provided for such apartments may be located in courts under the same conditions as prescribed for existing fire-escapes in §15-10(d).

(p) *Materials.* All fire-escapes hereafter constructed shall consist of outside open balconies and stairways of iron, stone, or other approved materials. Wherever the term wrought iron is used in these rules it shall be deemed to include all other especially approved metals.

Cast iron will not be permitted to enter into the construction of fire-escapes.

The use of old material in the construction of new fire-escapes is prohibited.

Bolts used in the construction or repair of fire-escapes shall be machine bolts. The use of stove bolts is prohibited.

The strength and construction of stone balconies hereafter erected forming part of the fire-escape shall be subject to the approval of the Department of Housing and Buildings.

All structural steel used in the construction of fire-escapes shall be at least one-quarter (0.25) inch in thickness.

(q) *Types of fire-escapes.* There shall be two types of fire-escapes: "Type A" and "Type B". Except for brackets and braces as hereafter described, what is applicable to one type is equally applicable to the other whether or not it is so stated

specifically.

(1) *Definition of "Type A" and "Type B" fire-escapes.* A "Type A" fire-escape [*sic*] is one which has a supporting bracket at each end of the balcony or platform.

A "Type B" fire-escape is one which has brackets not more than four feet (4') apart supporting the balcony or platform.

(2) Cantilever brackets will not be accepted for new fire-escapes on existing buildings.

(3) Details of other types of structural supports for fire-escapes must be submitted to and approved by the Department before being used in the construction of fire-escapes.

(4) "Type A" fire-escapes are not permitted on frame buildings, walls or hollow masonry constructions, on walls of solid masonry less than eight inches (8") in thickness nor on hollow walls of solid masonry unless complete construction details are submitted to and approved by the Department before the construction of fire-escapes.

(r) *Balconies.* All balconies, except those erected upon frame buildings and buildings having eight inch (8") brick walls, shall be not less than three feet four inches (3'-4") in width overall [*sic*] and may project into the public highway to a distance not greater than four feet (4') beyond the building line. Balconies erected upon frame buildings and buildings having eight inch (8") brick walls shall be thirty-six inches (36") in width. Balcony railings must be not less than two feet nine inches (2'-9") high.

(1) *Passageway.* Seventeen inches (17") in width is required between the strings of stairs and the wall, or between the strings of stairs and railings, clear of all projections to a height of six feet six inches (6'-6").

Fourteen inches (14") clear width is required between the hatchway railing and the window sill.

Seventeen inches (17") in width is required between the gooseneck ladder and the hatchway on the upper balcony.

(2) *Openings.* The openings for stairways in all balconies shall be not less than twenty-one inches (21") wide, and of such length as to provide at least six feet six inches (6'-6") clear headroom on all stairways at every tread, and shall have no covers of any kind.

A round, iron guard rail, three-quarter inch (3/4") in diameter shall be provided around all hatchways on all new balconies, and also, when necessary, around hatchways on existing balconies. Such guard rails shall be at least two feet six inches (2'-6") high and shall be properly braced at intervals of three feet (3') The brace from guard rail to the front top rail shall be so arranged to allow six feet six inches (6'-6") of headroom on the stairway.

Openings are not permitted in the floor of the lowest balcony of any new fire-escapes. Egress must be from a gateway in the front of end rail.

(3) *Top rails.* New top rails must be one and three-quarters inches by one-half inch (1 3/4" x 1/2") wrought iron or steel. Angle iron top rails will not be accepted. Separate bolt ends must be one and one-half inches by one-half inch (1 1/2" x 1/2") at connection with top rails and secured to the same by two three-eighths inch (3/8") bolts well upset.

No welded connections, other than shop welding, for top rails, will be permitted.

Top rails must go through the wall. When the wall is of brick, stone or concrete they must be anchored on the inner face thereof

Rules and Regulations

by means of nuts and four-inch by four-inch by three-eighths inch (4" x 4" x 3/8") washers. Where a masonry wall is eight inches (8") in thickness the washers shall be continuous and shall extend vertically from four inches (4") below the bracket anchorage to four inches (4") above the top rail.

Bolt ends must be at least three-quarters inch (3/4") in diameter. Top rails must be anchored in the wall at least nine inches (9") from the window or door opening.

On recess fire-escapes the top rails need not go through the wall, but must be hot leaded six inches (6") in brick or stone and at least twelve inches (12") from the outside face of the wall.

The front and return top rail, unless in one (1) piece, must be secured at the angle in the following manner: (1) with lap joint, by one-half inch (1/2") rivet and a strap of same dimension as the top rail, with one (1) three-eighths inch (3/8") rivet or bolt in each end of the strap; (2) with butt joint, by a triangular plate four inches by six inches by three-eighths inch (4" x 6" x 3/8") secured to each member of the top rail by two (2) three-eighths inch (3/8") rivets or bolts.

Top rails may be spliced with iron of the same dimensions as the rails with two (2) three-eighths inch (3/8") rivets or bolts on each side of the splice, or may be overlapped not less than eight inches (8") and secured by two (2) three-eighths inch (3/8") bolts or rivets.

Where front rails are not rigid they must be braced with outside braces. Said braces must be wrought iron not less than one and three-quarters inches by one-half inch (1 3/4" x 1/2") placed on edge. The braces must be properly spaced and secured to the extended brackets and top rails by three-eighths inch (3/8") rivets or bolts. Where brackets are extended to receive outside braces the extended portion must never less than two inches by one-half inch (2" x 1/2") and secured to the bracket by two (2) three-eighths inch (3/8") rivets or bolts.

Bow braces and overhead [*sic*] braces will not be accepted.

(4) *Bottom rails.* Bottom rails must be one and one-half inches by three-eighths inch (1 1/2" x 3/8") wrought iron and front rail of same must be secured to brackets by three-eighths inch (3/8") rivets or bolts.

Return bottom rails must be leaded or cemented in the wall when the latter is of brick, or may be secured to the brackets when this is practicable.

The [*sic*] bottom front and return rails must be connected at angles by at least one (1) three-eighths inch (3/8") rivet or bolt well burred.

They may be spliced as in the [*sic*] case of top rails.

(5) *Standards.* Standards must be not less than one-half inch (1/2") round or square set vertically, riveted to the top and bottom rails, not more than six inches (6") apart on centers. Special designs must be submitted for any variation, and approved before work is begun.

(6) *Floor slats.* Floor slats must be of wrought iron one and one-half inches (1 1/2") in width and three-eighths inch (3/8") thick and placed not more than one and one-quarter inches (1 1/4") apart.

In new balconies floor slats shall not project more than six inches (6") and in old balconies not more than eighteen inches (18"), beyond the end bracket and shall not be supported by the bottom rail.

All floors must be well secured to the brackets by three-eighths inch (3/8") "U" or clamp bolts.

Floor slats may be spliced with a four inch (4") splice plate [*sic*] three-eighths inch (3/8") thick, secured by three-eighths inch (3/8") countersunk or roundhead bolts or rivets on each side of the joint.

The ends of the floor slats must not project over stairs so as to overhang the top tread more than one-half inch (1/2"). The ends of such floor slats shall not be cut or burned off so as to be jagged or uneven. The floor slats shall be in true alignment.

(7) *Battens.* Battens must be one and one-half inches by three-eighths inch (1 1/2" x 3/8") not more than three feet (3') apart, riveted to the slats by five-sixteenth inch (5/16") rivets and so spaced as to secure rigidity.

No welded connections, other than shop welding, for top rails will be permitted.

Top rails must go through the wall. When the wall is of brick, stone or concrete they must be anchored on the inner face thereof by means of nuts and four-inch by four-inch by three-eighths inch (4" x 4" x 3/8") washers. Where a masonry wall is eight inches (8") in thickness the washers shall be continuous and shall extend vertically from four inches (4") below the bracket anchorage to four inches (4") above the top rail.

Bolt ends must be at least three-quarters inch (3/4") in diameter.

Top rails must be anchored in the wall at least nine inches (9") from the window or door opening.

On recess fire-escapes the top rails need not go through the wall, but must be hot leaded six inches (6") in brick or stone and at least twelve inches (12") from the outside face of the wall.

The front and return top rail, unless in one (1) piece, must be secured at the angle in the following manner: (1) with lap joint, by one-half inch (1/2") rivet and a strap of same dimension as the top rail, with one (1) three-eighths inch (3/8") rivet or bolt in each end of the strap; (2) with butt joint, by a triangular plate four inches by six inches by three-eighths inch (4" x 6" x 3/8") secured to each member of the top rail by two (2) three-eighths inch (3/8") rivets or bolts.

Top rails may be spliced with iron of the same dimensions as the rails with two (2) three-eighths inch (3/8") rivets or bolts on each side of the splice, or may be overlapped not less than eight inches (8") and secured by two (2) three-eighths inch (3/8") bolts or rivets.

Where front rails are not rigid they must be braced with outside braces. Said braces must be wrought iron not less than one and three-quarters inches by one-half inch (1 3/4" x 1/2") placed on edge. The braces must be properly spaced and secured to the extended brackets and top rails by three-eighths inch (3/8") rivets or bolts. Where brackets are extended to receive outside braces the extended portion must never be less than two inches by one-half inch (2" x 1/2") and secured to the bracket by two (2) three-eighths inch (3/8") rivets or bolts. Bow braces and overhead [*sic*] braces will not be accepted.

(8) *Landings.* Landings at the head and foot of stairs shall be at least forty inches by twenty inches (40" x 20") except on the balcony on the top story where the gooseneck ladder is located such landing shall be not less than forty inches by thirty inches (40" x 30"). On the lowest balcony where the opening to drop-ladder is in the return rail at front of the lowest tread the landing must be at least forty inches by thirty-six inches (40" x 36").

(9) *Egress from lowest balcony.* The gateway in the rail must

Rules and Regulations

be of sufficient width to permit the proper installation of the drop-ladder and guide-rods.

When the opening to the drop-ladder is in the return rail and at front of the lowest step, the landing at the foot of the stairs must be at least three feet by three feet, four inches (3' x 3'-4")*[sic]*.

Top rails must be well braced at the gateway.

(10) *Distance from lowest balcony to ground.* The distance from the lowest balcony to the ground or safe landing shall be not more than sixteen feet (16'-0") except that in existing multiple dwellings where due to structural conditions, such as plate glass store fronts, etc., it is not possible to erect such lowest balcony within sixteen feet (16'-0") of the ground, the Department of Buildings may permit such balcony to be erected at a height of not more than eighteen feet (18'-0") above the ground.

(11) *Termination of fire-escapes on extension roofs.* Where fire-escape stairs or ladders rest upon a fire-proof roof, no balcony need be provided at the foot of such stairs or ladders.

Where fire-escapes terminate on the roof of an existing extension, a guide-rod drop-ladder shall be provided at the level of the roof of such extension. Where the distance from such roof to a safe landing is more than sixteen feet (16'-0") an intermediate balcony not more than ten feet (10'-0") above a safe landing shall be provided, and such intermediate balcony shall be equipped with a guide-rod and drop-ladder and connected by means of a regulation stairway and balcony at the level of the extension roof.

Balconies, where required, must be anchored and constructed in a manner satisfactory to the Department of Buildings.

The roof of every extension used for egress, or upon which fire-escapes terminate, shall be fire-proof or fire-retarded according to the provisions of §15-10(m) of these Rules and Regulations.

(s) *Brackets and braces.*

(1) *"Type A".* All horizontal members of brackets and all cross beams shall be not less than four-inch (4") channels weighing not less seven and one-quarter (7.25) pounds to the linear foot.

The end bracket members shall enter the wall at a point not less than nine inches (9") from a door or window and shall be anchored on the inside face of the wall with an eight-inch by eight-inch by three-eighths inch (8" x 8" x 3/8") washer and a one-inch (1") bolt and nut. Where the wall is eight inches (8") in thickness the washer shall be continuous and shall extend across all brackets and cross beams. The bolt end shall be wrought iron not less than two inches by one-half inch (2" x 1/2") which shall be drawn out to form the necessary bolt end without welded connections. The bolt end shall be secured to the bracket with two (2) one-half inch (1/2") rivets. On eight-inch (8") walls the bolt end shall not be less than nine inches (9") long. On twelve-inch (12") walls the bolt end shall not be less than eleven inches (11") long. On sixteen-inch (16") walls the bolt end shall not be less than fifteen inches (15") long.

When the wall is eight inches (8") in thickness the bracket member shall enter the wall not less than seven inches (7").

When the wall is twelve inches (12") in thickness the bracket member shall enter the wall not less than eleven inches (11").

When the wall is sixteen inches (16") in thickness the bracket

member shall enter the wall not less than fifteen inches (15").

The intermediate cross beams shall enter the wall not less than eight inches (8") except where they enter the wall under the window. In such case the cross beam shall enter the wall not less than four inches (4").

The member forming the hatchway opening shall be a four-inch (4") channel iron weighing not less than seven and one-quarter (7.25) pounds per foot. It shall be secured to the intermediate cross beam with a three-inch by three-inch by one-quarter inch (3" x 3" x 1/4") lug and two (2) one-half inch (1/2") rivets or bolts.

The front bottom member of the fire-escape shall be of the following size and weights:

| <u>Length of Balcony</u> | <u>Weight of Channels</u> | <u>Size of Channels</u> |
|--------------------------|---------------------------|-------------------------|
| Up to 11 feet | 9.0 pounds per foot | 5 inches |
| Up to 13 feet | 10.5 pounds per foot | 6 inches |
| Up to 15 feet | 12.25 pounds per foot | 7 inches |
| Up to 17 feet | 13.75 pounds per foot | 8 inches |

The bracket braces shall be angle iron not less than two and one-half inches by two and one-half inches by one-quarter inch (2 1/2" x 2 1/2" x 1/4"). The braces shall drop not less than twenty-four inches (24") from the top of the bracket and shall extend out to a point not less than three-quarters (3/4) of the length of the bracket.

Each member of the brace shall be secured to the bracket with two (2) one-half inch (1/2") rivets.

The drop member of the brace shall be secured to the extended member with two (2) one-half inch (1/2") rivets.

The heel of the brace shall be cut out one-half inch (1/2") to allow for the drainage of water.

Where, owing to cornices, water-tables and porticos, it is impossible to use the standard brackets, inverted brackets may be used. When inverted brackets are used they shall be constructed with an upright wall member and a diagonal member. The wall member shall be an angle iron not less than three inches by four inches by three-eighths inch (3" x 4" x 3/8") and the diagonal member shall be an angle iron not less than three inches by three inches by three-eighths inch (3" x 4" x 3/8"). Each member shall be secured to the bracket with two (2) one-half inch (1/2") rivets.

The wall members shall be secured to the wall with (2) one-inch (1") bolts which shall pass through the wall and be anchored on the inside face of the wall with a washer four inches by three-eighths inch (4" x 3/8") which shall extend across the two (2) bolts. A one-inch (1") nut shall secure the washer to the bolt. The bolts shall be placed sixteen inches (16") apart on centers. The four-inch (4") member of the wall brace shall bear against the wall and shall extend from the bracket to and above the top return rail of the balcony. The top return rail of the balcony shall be secured to the wall member of the brace with two (2) one-inch (1") rivets or nuts and bolts. When inverted braces are used the bracket member shall enter the wall not less than four inches (4")

All other portions of "Type A" fire-escapes, except roof balconies, shall be constructed and erected as specified for the construction and erection of "Type B" fire-escapes.

(2) *"Type B".* The horizontal members of brackets shall consist of a one-piece wrought iron bar two inches by one-half inch

Rules and Regulations

(2" x 1/2") set so that the two inch (2") dimension is vertical. Brackets shall be not more than four feet (4'-0") apart. Welded brackets will not be accepted.

Angle iron brackets will not be accepted.

The top member of the bracket must be drawn out to form the necessary bolt end without welded connection.

Brackets shall be placed not less than eight inches (8") nor more than sixteen inches (16") below the window sill, except by special permission from this Department.

The top member of the bracket must go through the wall, and when the wall is of brick, must be anchored as specified for brackets in new buildings.

Brackets on buildings in course of erection must be built into the wall. They must be carried through the wall and turned down three inches (3") or the top member must be drawn out so as to form a bolt end one inch (1") in diameter and provided with nuts and with washers four inches by six inches (4" x 6") and three-eighths inch (3/8") in thickness, or where brackets on existing buildings or buildings in the course of erection pass through the walls under window or door openings, such brackets shall be anchored on the inside face of the wall with a four-inch by three-eighths inch (4" x 3/8") plate extending across the opening and bearing nine inches (9") on the inner face of each pier. In such case an additional one-half inch (1/2") bolt passing through wall and anchored to plate with one-half inch (1/2") nut shall be provided. If wall is recessed said bar must be shaped so as to bear on inner face of recessed wall and the ends of said bar to bear nine inches (9") on inner face of each pier. In addition a four-inch (4") steel channel stiffener must be provided to extend across the entire recessed portion. Blocking the recessed portion will not be permitted. Where walls are eight inches (8") in thickness the four-inch by three-eighths inch (4" x 3/8") plate must extend across and take in all brackets.

Special designs must be submitted for fire-escape framing other than standard and for masonry openings not included in above schedule.

Horizontal members of brackets must be braced with one-inch (1") square braces and shall rest on a shoulder. The braces shall be secured to the horizontal member with a rivet one-half inch (1/2") in diameter, at a point two-thirds (2/3) [sic] of the length of the horizontal member from the wall. The heel of the brace must be secured to the top member by a rivet of the same size.

The brace when entering the wall must be hot leaded in brick or stone three inches (3") and have a proper bearing on the face of the wall for at least eight inches (8").

If wedges are used to obtain full bearing against the wall, they must be of iron and well secured to the brace and must fill in solidly the space between brace and wall.

Anchorage in or bracing in terra cotta is not permitted.

Braces must drop at least one-third (1/3) of the length of the long brackets and must drop not less than eight inches (8") for short brackets.

Where a bracket is to receive additional weight on account of suspension rod for lower balconies, said bracket must be reinforced by an additional one-inch (1") square brace running from the end of the bracket parallel to the regulation brace.

Where it is impossible to brace the brackets in the manner described above, angle iron and tie rod supports must be used.

(3) *Anchorage for mullion windows, both "Type A" and "Type B".*

| Masonry Span | Brackets | Anchorage Member |
|--------------|------------|---|
| 5'-0" | 3'-6" long | 6" channel 10.5 pounds or 6" x 4" x 9/16" angle |
| 6'-0" | 3'-6" long | 7" channel 9.8 pounds or 6" x 4" x 1 1/16" angle |
| 7'-0" | 3'-6" long | 8" channel 11.5 pounds or 7" channel 12.25 pounds |
| 8'-0" | 3'-6" long | 8" channel 11.5 pounds |
| 9'-0" | 3'-6" long | 8" channel 13.75 pounds |
| 5'-0" | 4'-0" long | 8" channel 11.5 pounds or 6" x 4" x 3/4" angle |
| 6'-0" | 4'-0" long | 8" channel 11.5 pounds |
| 7'-0" | 4'-0" long | 8" channel 13.75 pounds |
| 8'-0" | 4'-0" long | 8" channel 16.25 pounds |
| 9'-0" | 4'-0" long | 8" channel 21.25 pounds |

Notes:

1-Working stresses taken at 16,000 pounds per square inch.

2- Load taken at 100 pounds per sq. ft. and includes live and dead loads.

3- Loads on anchorage members due to bracket reaction placed for maximum bending moment produced in member.

4- Bearing plates of suitable size must be provided for brackets taking ladder load and for anchorage members.

6" x 4 9/16" angle weighs 18.1 pounds per lin. ft.

6" x 4 1 1/16" angle weighs 21.8 pounds per lin. ft.

6" x 4 3/4" angle weighs 23.6 pounds per lin. ft.

Angle irons to support balconies where regulations braces cannot be used shall not be less than four inches by four inches by three-eighths inch (4" x 4" x 3/8"). Tie rods shall not be less than one inch (1") in diameter and shall be anchored through the wall in the same manner as brackets.

The angle iron support in such cases shall be set so that the tie rods will pull toward the heaviest part of the webs.

When it becomes necessary to shift a bracket from one location to another in order to carry the stairs, a new regulation two inch by one-half inch (2" x 1/2") bracket shall be installed.

No welded brackets, corroded brackets or brackets set flat with cast iron under-bracing will be accepted. Such brackets shall be replaced, whenever found, by a two-inch by one-half inch (2" x 1/2") regulation bracket. However, when a two inch by one-half inch (2" x 1/2") bar bracket with cast iron under-bracing is found, said bracket may be permitted to remain if proper one inch (1") square under-bracing is provided.

(t) *Stairways.* All stairways shall be placed at an angle of not more than sixty (60) degrees with flat open steps not less than six inches (6") in width and twenty inches (20") in length and with a rise of not more than nine inches (9").

(1) *Treads.* Treads of such construction as may be approved by the Department from time to time will be permitted.

Flat iron bars forming treads must be one and one-half inches by three-eighths inch (1 1/2" x 3/8") and spaced not more than

Rules and Regulations

three-quarters of an inch (3/4") apart.

Bars forming treads must be secured to supporting angle irons by three-eighths inch (3/8") rivets and these angle irons must be fastened to the strings by two (2) three-eighths inch (3/8") rivets or bolts, well burred. Galvanized angle irons one and one-half inches by one and one-half inches by one-quarter inch (1 1/2" x 1 1/2" x 1/4") will be accepted but if not galvanized, said angle irons shall be one and one-half inches by one and one-half inches by three-eighths inch (1 1/2" x 1 1/2" x 3/8"). In all cases the vertical legs of the angle irons must be set tightly against the strings so that there will be no intervening spaces.

All treads must be set level and must not overhang so as to interfere with foot room on the tread below.

(2) *Patented treads.* Patented treads approved by the Department of Buildings or previously approved by the Board of Standards and Appeals for new installations will be accepted by the Department of Buildings as legal for use in buildings under its jurisdiction. Five samples of approved treads to be furnished to the Department of Buildings (one delivered to each borough) as a permanent record.

(3) *Strings.* Where the strings of the stairs are adjacent to the front rails the strings must be securely fastened to the top rails. Strings must be braced by round bars three-quarters inch (3/4") in thickness, properly hot-leaded or secured by four inches by three-eighths inch (4" x 3/8") expansion bolts in brick or stone wall at height of not less than six feet six inches (6'- 6") [sic] in the clear above the floor of the balcony. Strings of stairways shall be four inches by three-eighths inch (4" x 3/8") wrought iron and shall rest on a bracket at the bottom and be bolted to a bracket at the top.

Welded strings, other than shop welded, will not be accepted.

(4) *Hand rails.* Hand rails must be of wrought iron, three-quarters inch (3/4") round or one and one-half inches by three-eighths inch (1 1/2" x 3/8") bar, well braced with intermediate braces not more than five feet (5'-0") apart, and of the same size and material as the hand rail, and secured to the strings with two (2) three-eighths inch (3/8") rivets at each end and at each brace; or handrails may be secured to the bottom rail of the upper balcony and top rail of the lower balcony by two (2) three-eighths inch (3/8") rivets at each end.

On all fire-escapes hereafter erected double hand rails must be provided for all stairways.

(u) *Drop-ladder.* A drop-ladder shall be provided from the lowest balcony and be of sufficient length to reach a safe landing place beneath. The drop-ladder shall be fifteen inches (15") in width, shall be placed in guides and shall be not more than sixteen feet (16'-0") in length.

Except in multiple dwellings hereafter erected or converted, where the distance from the lowest balcony to a safe landing place is more than sixteen feet (16'-0") but because of structural conditions, such as plate glass store fronts, etc., a balcony is not possible, the department may accept a drop-ladder in guides, if the distance from the floor of the lowest balcony to a safe landing place is not more than eighteen feet (18'-0")

No drop-ladder is required where the distance from the lowest balcony to a safe landing place does not exceed five feet (5'-0").

No drop-ladder will be permitted to land or terminate on a stoop or any part thereof unless the written approval of the Department

of Buildings is obtained.

(1) *Guides.* All drop-ladders shall have guides provided with stops so that the ladders cannot be raised above the same. The [sic] drop-ladder must be suspended from a point directly over the opening in the rail of the balcony and arranged to slide in the guides so as to drop in position for use. All [sic] drop-ladders shall be provided with a shoe at the bottom.

The guides shall be constructed of one and one-half inches by one and [sic] one-half inches by one-quarter inch (1 1/2" x 1 1/2" x 1/4") angle iron, and shall be not less than twenty-one inches (21") apart.

(2) *Strings.* Strings of drop-ladders must be one and one-half inches by three-eighths inch (1 1/2" x 3/8") bar. No welded drop-ladders will be accepted unless shop welded.

(3) *Rungs.* The rungs must be five-eighths inch (5/8") in thickness, not over twelve inches (12") apart [sic] and must be riveted to the strings.

(v) *Gooseneck ladder.* The top balcony of every fire-escape shall be provided with a stair or with a gooseneck ladder leading from said balcony to and above the roof, except that no such stairs or gooseneck ladders will be required in the following locations or under the following conditions:

(1) On multiple dwellings with peak roofs having a pitch of more than twenty (20) degrees.

(2) Where fire-escapes are located on the fronts or in street courts of multiple dwellings facing upon the street.

Where a multiple dwelling does not face upon the street, such as a multiple dwelling located at the rear of a lot upon which there is another building, every fire-escape on such multiple dwelling shall be provided with a stair or gooseneck ladder as required above, except where the roof of such building has a pitch more than twenty (20) degrees as stated in exception (1) above.

Except as provided in exceptions (1) and (2) above, every fire-escape on every hereafter erected or converted multiple dwelling, and every new fire-escape hereafter provided on every existing multiple dwelling shall be provided with a regulation stairway from the top balcony to the roof when such buildings exceed four (4) stories in height. In such multiple dwellings exceeding four (4) stories in height when due to special structural conditions which would not permit the erection of a stair from the top balcony to the roof or where the height from the top balcony to the roof may [sic] be such as to make the installation of a stair impractical, the Department of Buildings may accept a gooseneck ladder in lieu of a regulation stairway.

The top balcony of a fire-escape on every multiple dwelling not exceeding four (4) stories in height may be equipped with a gooseneck ladder.

(i) *Construction and location of gooseneck ladders.* The gooseneck ladder shall be fifteen inches (15") wide and shall be so located that it will not obstruct egress from the apartment or apartments on the top floor. The effective opening between the side of any window and the string of gooseneck ladder shall be not less than twenty-four inches (24")

The gooseneck ladder must be fourteen inches (14") from the front rail on existing balconies and twenty-one inches (21") on balconies hereafter erected.

(ii) *Strings.* The gooseneck ladder must be constructed with one piece of [sic] strings [sic] two inch by one-half inch (2" x 1/2") wrought iron.

Rules and Regulations

Strings must be directly secured to the brackets or secured to a two inch by one-half inch (2" x 1/2") bar bearing on two (2) brackets and well secured to strings and brackets by three-eighths inch (3/8") bolts or rivets.

Strings must be spread at the parapet wall or roof to give a passageway of eighteen inches (18")

Strings must be tied through the wall by braces going through the parapet immediately above the roof, or, in the absence of the parapet wall, the said braces must go through the wall immediately below the ceiling of the top floor and be secured by three-quarters inch (3/4") bolts and four inches by four inches by three-eighths inch (4" x 4" x 3/8") washers.

The gooseneck ladder strings must extend thirty inches (30") above the roof level. Where there is a parapet, a gateway at the roof level shall be provided.

The strings of the gooseneck ladder must be secured to and braced at the roof.

(iii) *Rungs.* Rungs shall be of wrought iron five-eighths inch (5/8") thick, spaced not more than twelve inches (12") apart and shall be riveted through the strings.

The top rung of all gooseneck ladders shall be level with the roof.

(w) *Painting.* Section 53, Multiple Dwelling Law, required new fire-escapes to have two (2) coats of paint. The Department of Buildings will require these two (2) coats to be applied on contrasting colors, the first coat at the shop before erection, and the second coat applied after erection.

Existing fire-escapes shall be repainted whenever deemed necessary.

(x) *Exceptions.* Any deviations or exceptions from these rules other than those specifically mentioned herein shall be submitted to the Department of Buildings for approval. Consent and approval shall be in written form and bear the signature of the commissioner, deputy commissioner, superintendent or the person designated to sign such consent by the commissioner, deputy commissioner or superintendent.

(y) *Fire-escapes on frame buildings.* Fire-escapes shall be constructed as for brick or stone buildings with the following exceptions, and except also that balconies three feet (3'-0") wide will be acceptable to the department.

(1) *Brackets.* Horizontal members of brackets must be one and three-quarters inches by one-half inch (1 3/4" x 1/2") wrought iron set on edge; one inch (1") bolt end through a four inches by three-eighths inch (4" x 3/8") iron plate, long enough to take in all brackets, secured to and bearing directly on the inside of the studs. Spaces between the studs behind such plates shall be filled in solidly with timber secured to the studs.

The heel of bracket braces must rest against one and three-quarter inches by one and three-quarter inches by one-quarter inch [sic] high (1 3/4" x 1 3/4" x 1/4") angle iron extended across and well secured to studs.

(2) *Top rails.* Top rails shall be anchored by three-quarters inch (3/4") [sic] bolt ends, through a four inch by three-eighths inch (4" x 3/8") wrought iron plate spanning at least two (2) studs. Space behind plate and between studs shall be blocked solidly.

(3) *Bottom rails.* Bottom rails shall be secured to the siding in a substantial manner with two (2) one and one-quarter inch (1 1/4") No.14 wood screws, or may be secured to the brackets

where practicable.

(4) *Stairways.* Stair braces shall be secured to the wall of the building by two (2) No. 14 wood screws.

(z) *Outside fireproof stairs.* Outside fireproof stairs shall be constructed according to approved plans and applications of the Department of Buildings. Such regulations that [sic] as govern the measurements of inside stairs shall be applied to outside fireproof stairways except that in multiple dwellings not exceeding three (3) stories and basement in height, fireproof stairway leading from a front porch roof which is fireproof to the fireproof floor of an unenclosed porch will be deemed an outside fireproof stairways and such stairways may be of the same width as the ordinary fire-escape stairs. Area covered by fireproof outside stairs must not encroach upon the minimum dimensions of yard and courts.

(aa) *Fire towers.* Fire towers shall be constructed according to approved plans and applications filed with the Department of Buildings.

(bb) *Egress.* Hotels and certain other class A and class B dwellings which are subject to the provisions of §67, Multiple Dwelling Law [sic].

(1) *Exceptions.* Any such multiple dwelling, altered or erected after April fifth, nineteen hundred forty-four, and which is required to conform to the provisions of articles one, two, three, four, five, eight, nine and eleven of Multiple Dwelling Law, shall not be required to conform to the provisions of §15-10(bb)(1)(i), (2), (3) and (4).

(i) Except in fireproof class A multiple dwellings erected under plans filed after January first, nineteen hundred twenty-five, and which were completed before December thirty-one, nineteen hundred thirty-three, and except as otherwise provided in paragraph (4) of subdivision (bb) of this section, in every such dwelling three (3) or more stories in height there shall be from each story at least two (2) independent means of unobstructed egress located remote from each other and accessible to each room, apartment or suite.

(2) *First means of egress.* The first means of egress shall be an enclosed stair extending directly to a street, or to a yard, court or passageway affording continuous, safe and unobstructed access to a street, or by an enclosed stair leading to the entrance story, which story shall have direct access to a street. The area of the dwelling immediately above the street level and commonly known as main floor, where the occupants are registered and the usual business of the dwelling is conducted, shall be considered a part of the entrance story; and a required stair terminating at such main floor or its mezzanine shall be deemed to terminate at the entrance story. An elevator or unenclosed escalator shall never be accepted as a required means of egress.

(3) *Second means of egress.* The second means of egress shall be by an additional enclosed stair conforming to the provisions of §15-10(bb)(2), a fire-stair, a fire-tower or an outside fire-escape. In a non-fireproof dwelling when it is necessary to pass through a stair enclosure which may or may not be a required means of egress to reach a required means of egress, such stair enclosure and that part of the public hall or corridor leading thereto from a room, apartment or suite, shall be protected by one (1) or more sprinkler heads; in a fireproof dwelling only that part of the hall or corridor leading to such stair enclosure need be so protected.

(4) *Required second means of egress-impractical.* Where it is impractical in such existing dwellings to provide a second

Rules and Regulations

means of egress, the department may order additional alteration to the first means of egress and shafts, stairs and other vertical openings as the department may deem necessary to safeguard the occupants of the dwelling, may require the public halls providing access to the first means of egress to be equipped on each story with one (1) or more automatic sprinkler heads, and, in non-fireproof dwellings, may also require automatic sprinkler heads in the stair which serves as the only means of egress.

(5) *Public halls and corridors providing access to fire-escapes.* Public halls and corridors providing access to fire-escapes, existing and new, are acceptable when a direct and uninterrupted line to travel to the fire-escape is provided.

Public halls and corridors providing access to fire-escapes shall be fire-retarded or shall be equipped with automatic sprinkler heads. The fire-retarding and sprinkler installation shall be in conformity with the rules and regulations of this department and as required by §67 (3) of the Multiple Dwelling Law.

All openings which provide direct access to an existing fire-escape from a public hall or corridor shall be equipped with fireproof doors and assemblies with the doors self-closing or fireproof windows glazed with clear wire glass. Access to new fire-escapes from such halls or corridors shall be by means of fireproof doors and assemblies with doors self-closing. Doors providing access to fire-escapes from public halls or corridors may be glazed with clear wire glass.

(6) *Fire-escapes-existing and new.* Existing fire-escapes which are structurally strong and in good repair, having connecting stairways set at an angle or not more than sixty-five (65) degrees, may be accepted as a secondary means of egress.

Except as otherwise required herein, new and existing fire-escapes shall be provided with a safe landing and the termination shall lead directly to a street or to a passageway which provides access to a street.

When it is impractical to provide a termination for fire-escapes as specified in these Rules, the Department may accept a termination from such fire-escapes which leads to safety.

(7) *Supplementary means of egress.* A stair, fire-stair, fire-tower, or fire-escape which is supplementary to the egress requirements of §15-10(bb)(2), (3) and (4), need not lead to the entrance story or to a street, or to a yard or a court which leads to a street, provided the means of egress therefrom is approved by the department.

Fire-escapes which are supplementary to the required second means of egress, including fire-escapes of the inclined ladder and vertical ladder types, may remain on the dwelling if maintained in good order and repair, are structurally strong and safe and are provided with safe landing and the termination thereof leads to safety in a manner satisfactory to this Department.

(8) *Signs-supplementary means of egress.*

Supplementary stairs, fire-stairs, fire-towers or fire-escapes which do not lead to the entrance story or to a street, or to a yard or court leading to a street, shall be clearly marked "NOT AN EXIT" in black letters at least four inches (4") high on a yellow background and at the termination of each such stair, fire-stair, fire-tower or fire-escape, there shall be a directional sign indicating the nearest means of egress leading to a street. All signs shall be constructed, located and illuminated in a manner satisfactory to the department.

(9) *Signs-general provisions.* Every means of egress shall

be indicated by a sign reading "EXIT" in red letters at least eight inches (8") high on a white background, or vice versa, illuminated at all time during the day and night by a red light of at least twenty-five (25) watts or equivalent illumination. Such light shall be maintained in a keyless socket. On all stories where doors, openings or passageways giving access to any means of egress are not visible from all portions of such stories, directional signs shall be maintained in conspicuous locations, indicating in red on a white background, or vice versa, the direction of travel to the nearest means of egress. At least one sign shall be visible from the doorway of each room or suite of rooms. Existing signs and illumination may be accepted if, in the opinion of the department, such existing signs and illumination serve the intent and purpose of this subdivision.

(10) *Stairs, fire-stairs and fire-towers.* Stairs, fire-stairs and fire-towers hereafter provided shall be constructed according to plans and applications approved by the Department of Buildings.

(cc) *Egress: lodging houses.*

(1) *Arrangement.* There shall be at least two (2) means of unobstructed egress from each lodging-house story, which shall be remote from each other. The first means of egress shall be to a street either directly or by an enclosed stair having unobstructed direct access thereto. If the story is above the entrance story, the second means of egress shall be by an outside fire-escape constructed in accordance with the provisions of section fifty-three, Multiple Dwelling Law, or by an additional enclosed stair. Such second means of egress shall be accessible without passing through the first means of egress.

(2) *Doors and windows.* All doors opening upon entrance halls, stair halls, other public halls or stairs, or elevator, dumbwaiter or other shafts, and the door assemblies, shall be fireproof with the doors made self-closing by a device approved by the department, and such doors shall not be held open by any device whatever. All openings on the course of a fire-escape shall be provided with such doors and assemblies or with fireproof windows and assemblies, with the windows self-closing and glazed with wire glass, such doors or windows and their assemblies to be acceptable to the department.

(3) *Aisles.* There shall be unobstructed aisles providing access to all required means of egress in all dormitories. Main aisles, approved as such by the department to provide adequate approaches to the required means of egress, shall be three feet (3'-0") or more in width, except that no aisles need be more than two feet six inches (2'-6") wide if it is intersected at intervals of not more than fifty feet (50'-0") by cross-over aisles at least three feet (3'-0") wide leading to other aisles or to an approved means of egress.

(4) *Signs.* Every required means of egress from the lodging-house part of the dwelling shall be indicated by a sign reading "EXIT" in red letters at least eight inches (8") high on a white background illuminated at all times during the day and night by a light at least twenty-five (25) watts or equivalent illumination. Such light shall be maintained in a keyless socket. On all lodging-house stories where doors, openings, passageways or aisles are not visible from all portions of such stories, and in other parts of the dwelling which may be used in entering or leaving the lodging-house part and in which a similar need exists, signs with easily readable letters at least eight inches (8") in

Rules and Regulations

height, and continuously and sufficiently illuminated by artificial light at all times when the natural light is not sufficient to make them easily readable, shall be maintained on conspicuous locations, indicating the direction of travel to the nearest means of egress. At least one (1) such sign shall be easily visible from the doorway of each cubicle.

(5) *Roof egress*. Access from the public hall at the top story to the roof shall be provided by means of a bulkhead or a scuttle acceptable to the department. Every such scuttle and the stair or ladder leading thereto shall be located within the stair enclosure.

(6) *Persons accommodated*. The number of persons accommodated on any story in a lodging house shall not be greater than the sum of the following components:

(i) Twenty-two (22) persons for each full multiple of twenty-two inches (22") in the smallest clear width of each means of egress approved by the department, other than a fire-escape.

(ii) Twenty (20) [*sic*] persons for each lawful fire-escape accessible from such story if it is above the entrance story.

(7) In view of the fact that §66, Subdivision 3 (formerly §13, subdivision m), Multiple Dwelling Law, required lodging houses to be sprinkled throughout, including the public halls, the department will accept existing double-rung ladder type fire-escapes on the condition that such fire-escapes are maintained in a good state of repair.

(dd) *Ladders leading to roof scuttles*. Ladders to roof scuttles as required under the provisions of §§187 and 233 of the Multiple Dwelling Law, shall be of incombustible material, not less than fifteen inches (15") wide, with strings not less than one and one-half inches by three-eighths inch (1 1/2" x 3/8"), with five-eighths inch (5/8") rungs not more than twelve inches (12") apart. Strings of such ladders shall be secured at top and bottom and ladder must be so arranged as to permit sufficient toe hold.

CHAPTER 16 INSPECTION OF EXISTING STRUCTURES DURING CONSTRUCTION OPERATIONS

§16-01 Controlled Inspection of the Stability and Integrity of Existing Structures During Construction Operations

(a)(1) All alterations to existing structures in which loads are transferred from one system of structural elements to another such as in the installation of columns or girders to replace existing bearing walls, the creation of openings or slots in existing bearing walls, girders or floors, or where the stability or integrity of a structural system is to be temporarily diminished, shall be conducted under controlled inspection.

(2) The Department of Buildings will not approve any plans or amendments thereto where work, as described in §16-01(a)(1), is to be performed unless a registered architect or professional engineer (hereinafter referred to as "controlled inspection architect or engineer") retained by the contractor or owner and approved by the registered architect or professional engineer seeking approval of such plans submits to the Department a Technical Report: Statement of Responsibility ("TR-1") or any similar document which the Department may use in the future whereby the controlled inspection architect or engineer assumes responsibility for the controlled inspection of the existing structure during construction operations to determine

its stability and integrity.

(b)(1) The details of shoring, bracing or other construction required for such work and the phasing, staging, and sequence of such operation shall be:

(i) Shown on the structural plans that are submitted to and approved by the Department or,

(ii) Prepared in the form of shop or detail drawings by a registered architect or professional engineer authorized, retained, or hire by the owner, contractor, or sub-contractor, and reviewed by the registered architect or professional engineer who prepared the structural plans.

(c) The controlled inspection architect or engineer shall retain a copy of the documents described in § 16-01(b) in his or her office and shall provide a copy to the contractor and/or owner to be kept at the construction site.

(d) The controlled inspection architect or engineer shall determine the frequency of inspections needed and whether he or she should inspect the site personally or send a person under his or her direct supervision. At a minimum, the site must be inspected twice, once at a pre-construction meeting with the contractor and once during construction operations.

(e)(1) The controlled inspection architect or engineer, for each job which requires the submission of a TR-1 pursuant to §16-01(a)(2), shall maintain a log in his or her office which includes the following information:

(i) address of the premises, job number, contractor name and address, and

(ii) date and time of each inspection including (A) names of personnel who inspected the site, and (B) any significant observations or instructions given relating to any of the following:

((a)) deviations from the documents described in §16-01(b);

((b)) anticipated field conditions;

((c)) proper execution of the work;

((d)) good engineering practice;

((e)) safe job-site conditions;

((f)) precautions taken to maintain safe conditions if work is stopped for any reason.

(iii) the date of and participants in any conversations with the controlled inspection architect or engineer occurring off-site and relating to any significant observations or instructions specified in §16-01 (e)(1)(ii)(B)((a)) through ((f)).

(f) he controlled inspection architect or engineer shall report unsafe conditions to the Department of Buildings and/or any other affected parties or agencies.

(g) Upon request of the Department, the controlled inspection architect or engineer shall make available for review by the Department documents described in §16-01(b) and the log described in §16-01(e).

(h) *Exemption of Frame Structures*. Frame structures shall be exempt from these rules and regulations except for the alteration of arches, rigid frames, trusses and the creation of openings exceeding 10 feet in length in bearing walls.

CHAPTER 17 TESTING LABORATORIES AND TESTING SERVICES

§17-01 Acceptance of Testing Laboratories and Testing Services

(a) Applications for acceptance as a testing service or

Rules and Regulations

testing laboratory shall be submitted to the Commissioner of Buildings on forms provided by the Department.

(b) Each laboratory shall have in responsible charge a Director who shall be qualified by education, experience, or other accreditation acceptable to the Commissioner for the scope of testing performed, who shall personally supervise the testing of materials or service equipment for acceptance by the Department of Buildings.

(c) All technicians shall be qualified by education, experience, or other accreditation acceptable to the Commissioner to perform all tests they may be required to conduct under the supervision of the Director.

(d) The laboratory shall furnish to the Department of Buildings a list of all personnel who are supervising and performing tests and their qualifications.

(e) The laboratory shall furnish to the Department of Buildings a list of all the equipment used to perform tests, the manufacturer's name, when and by whom it was last calibrated.

(f) The laboratory and its equipment may be inspected periodically by the Department of Buildings or competent independent agency acceptable to the Department. If such an agency is used, a certified copy of its report shall be submitted to the Department of Buildings.

(g) The laboratory shall correct within 10 days any condition which, in the judgment of the Department of Buildings, may adversely affect the result of any test.

(h) A list of acceptable laboratories or testing services will be maintained in the office of the Commissioner of Buildings and made available to the public.

(i) The Department shall issue a serial numbered Certificate of Acceptance which shall be prominently displayed on the test premises. Such certificate shall bear the name of the lab or service, the name of the professionally qualified Director and the field or trade for which the laboratory has established its competence.

(j) All test reports shall be presented in a form acceptable to the Department and bear the name of the laboratory or service and its acceptance number, the name of the Director who supervised the test, the names of all qualified personnel who performed the test, and the names of all witnesses.

(k) The accepted laboratory or service shall prepare and submit to the Department a copy of the certificate or label bearing its name and acceptance number which it shall be required to affix to all shipments and deliveries of material or equipment when the laboratory is engaged by the manufacturer or producer to make periodic inspections or tests of the material or equipment in the course of manufacture or production.

(l) Accepted laboratories and testing services shall be permitted to advertise the fact of their acceptance by the Department of Buildings of The City of New York for the testing of materials or equipment only in the field or trade for which they have established their competence.

(m) Any violation of these rules or misrepresentation of facts in any required report or misrepresentation in advertising shall constitute cause for revocation or suspension of acceptance by the Commissioner.

CHAPTER 18 RESISTANCE TO PROGRESSIVE COLLAPSE UNDER EXTREME LOCAL LOADS

§18-01 Considerations and Evaluation.

(a) *General considerations.* Unless all members are structurally connected by joints capable of transferring 100% of the members' working capacity in tension, shear, or compression, as appropriate, without reliance on friction due to gravity loads, the layout and configuration of a building and the interaction between, or strength of, its members shall provide adequate protection against progressive collapse under abnormal load, where progressive collapse is interpreted as structural failure extending vertically over more than three stories, and horizontally over an area more than 1,000 square feet or 20 percent of the horizontal area of the building, whichever is less. These criteria shall be satisfied while the building is subjected to its own weight D plus a superimposed load of $(1.0D + 0.25L)$, where D is computed according to Article 2 of Subchapter 9 of Chapter 1 of Title 27 of the Administrative Code and according to Reference Standard RS 9-1 of the same Code and L is computed according to Article 3 of Subchapter 9 of Chapter 1 of Title 27 of the Administrative Code and according to Reference Standard RS 9-2 of the same Code without allowance for the live load reduction permitted in Article 4 of Subchapter 9 of Chapter 1 of Title 27 of the same Code. A wind load of $0.2W$ shall be assumed to act in combination with $1.0D + 0.25L$, where W is computed according to Article 5 of Subchapter 9 of Chapter 1 of Title 27 of the Administrative Code and according to Reference Standard RS 9-5 of the same Code. These criteria shall be satisfied in accordance with structural analysis based on the Plastic Design or Ultimate Strength method, representing conditions at incipient failure and shall be considered as an independent check of a building designed in accordance with the usual procedures for Working Stress, Plastic Design, or Ultimate Strength design pursuant to Subchapters 9, 10, and 11 of Chapter 1 of Title 27 of the Administrative Code and all applicable Reference Standards thereto.

(b) *Methods of evaluation.*

Resistance to progressive collapse shall be determined by one of two methods:

(1) *The Alternate Path Method.*

(2) *The Specific Local Resistance Method.*

The specific local resistance method shall only be used if the alternate path method is not feasible.

(i) *The Alternate Path Method.*

Proof shall be provided, by analysis and/or physical simulation, that the following condition is satisfied while the building is subjected to the loads stipulated in the criteria:

(A) Should any one of the following combinations of structural elements at any one story lose its ability to carry load, there shall be no collapse of the structure more than one story above or below the element under consideration, or over a horizontal area in excess of that stipulated in the criterion:

(a) Any single "wall panel or nominal length thereof."

(b) Two adjacent "wall panels or nominal lengths thereof" forming an exterior corner to the building.

(c) One or more elements forming a "nominal extent of flooring".

(d) One column.

(e) Any other one element of the structural subsystem which is judged to be vital to the building's stability.

(B) The following definitions specifically apply to Method (b)(1):

(a) The designation "wall panel or nominal length thereof" is the smaller of the following lengths as appropriate to the design in

Rules and Regulations

question:

- (1) The length between adjacent lateral supports.
- (2) The length between a free edge and the nearest lateral support.
- (3) A length equal to 2.25 times the clear height of the wall panel in those circumstances where the top and bottom attachment of the panel to the floor or roof will not fail under a force smaller than 3 kips [*sic*] per linear foot acting perpendicular to the wall in either direction.

(b) As used above, "lateral support" is considered to occur at:

- (1) A substantial partition perpendicular to the wall, provided that its attachments to the wall and the partition itself are capable of resisting and transmitting without failure a horizontal force of 3 kips [*sic*] per foot of clear wall height in either direction in the plane [*sic*] of the partition. A partition may be considered substantial when that partition or a combination of such partitions, one above the floor and one below the floor and substantially in the same plane, is able to resist the following distributed force transmitted by the floor in the plane of the partition and in an upwards or downwards direction:

$0.18 \frac{S}{b}(2b-S)$ kips [*sic*] per foot of clear span.

b

where *b* is clear span and *S* is the clear spacing of partitions or the clear distance from a partition to an adjacent free edge of the floor.

- (2) A strengthened vertical portion of the wall (not exceeding 1/3 story height in the horizontal direction) which will not fail under a load of 3 kips [*sic*] per linear foot of clear wall height acting perpendicular to the plane of the wall in either direction along the interface between the strengthened wall portion and the portion of the wall that lost its load carrying capacity.

(c) The term "nominal extent of floor" denotes the following:

- (1) For a floor spanning in one direction, the extent is the clear span. In the perpendicular direction the extent is to be taken as the smaller of the following:

(i) The distance between adjacent "substantial" partitions arranged in the direction of floor span.

(ii) The distance between a free edge and the nearest "substantial" partition arranged in the direction of the floor span.

(iii) In the case where partitions are not "substantial" the extent is to be taken as 2.25 times the clear span.

- (2) For a floor spanning in two directions the extent shall be taken as the area bounded by the clear spans in both directions.

(ii) Specific local resistance methods.

Any single element essential to the stability of the structure, together with its structural connections, shall not fail under the loads stipulated in this criterion after being subjected to a load equivalent to that caused by a uniform static pressure of 720 psf. This pressure shall be applied in the most critical manner to the face of the element and to the face of all space dividers supported by the element or attached to it within the particular story. In those cases where the stability of the element depends upon the lateral support provided by the attached space dividers, these space dividers, or a portion of these space dividers which can provide adequate lateral support, must also satisfy requirements of this paragraph.

CHAPTER 19 MASTER PLUMBERS AND LICENSED FIRE SUPPRESSION PIPING CONTRACTORS

§ 19-01 Examination, License and Conduct of the Business of Master Plumbers and Master Fire Suppression Piping Contractors.

(a) *Applicability.* This rule shall be applicable to the examination, licensure and conduct of the businesses of master plumber and 1 master fire suppression piping contractor.

(b) *Applications.* Any person desiring to obtain a license from the Commissioner of Buildings to engage in the business or trade of Master Plumber or Master Fire Suppression Piping Contractor shall file an application as required by §§26-145 and 148 of the Administrative Code.

(c) *Qualifications.* Every person applying for a Master Plumber's license or Master Fire Suppression Piping Contractor's license shall pass an examination and otherwise meet the qualifications of §§26-145, 146 and 148 of the Administrative Code.

**(e) Issuance of licenses, plates and renewals - fees.*

**"(e)" enacted but "(d)" probably intended.*

(1) Upon the certification that an applicant has satisfactorily passed a written and a practical examination, the Commissioner of Buildings shall issue to the applicant a Master Plumber's license or Master Fire Suppression Piping Contractor's license together with a plate and seal upon the following conditions:

(i) Payment of a certificate fee pursuant to § 26-147 of the Administrative Code and

(ii) Representation by the applicant, subject to verification by the Department of Buildings, that the applicant has an established "place of business" within the City of New York, and

(iii) Payment of "licensed plumber" or "licensed fire suppression piping contractor's license" plate and seal fees as required by §26-147 of the Administrative Code, for which the Department of Buildings shall issue a plate for use at the premises designated by the applicant as his or her "place of business."

(iv) For purposes of renewal of said license, thirty to sixty calendar days prior to the license's expiration date, the applicant shall present to the Department of Buildings, in such manner as the Commissioner may require, proof that the applicant has satisfactorily completed a seven hour continuing education course approved by the Department of Buildings within two years prior to the renewal date, as required by § 26-150.1 of the Administrative Code, and such identification and other documentation supporting his or her right to renewal as the Commissioner may require. All applicants for renewal shall be of good moral character at the time of renewal. The applicant for renewal shall pay the renewal fee required by §26-147 of the Administrative Code. The license plate and seal shall be renewed every two years.

(2) Where the plate or seal has been lost, and an affidavit is submitted to this effect, a new plate or seal shall be issued by the Commissioner of Buildings upon an application and payment of a fee as required by §26-147 of the Administrative Code.

(f) *Place of business regulated.*

(1) A "place of business" shall mean the location of a plumbing establishment or fire suppression piping establishment where a Licensed Master Plumber or Licensed Master Fire Suppression Piping Contractor conducts his or her business. A plumbing or fire suppression piping establishment may be conducted by a Licensed Master Plumber or Licensed Master Fire Suppression Piping Contractor under a trade name, or by a partnership or

Rules and Regulations

corporation, or other business association duly authorized to conduct a plumbing or fire suppression piping business.

(2) The "place of business" is the location of the office and shop of a plumbing or fire suppression piping establishment where the office and shop are at the same location.

3) The "place of business" where the location of the office portion of a plumbing or fire suppression piping establishment is different from the shop portion, shall be the place where the office portion is located.

(4) The "place of business" where no plumbing or fire suppression piping shop exists shall be the location of the office from where the Licensed Master Plumber or Licensed Fire Suppression Piping Contractor conducts his or her business.

(5) The office portion of a plumbing or fire suppression piping establishment which is located at a different location than the shop portion, shall be the place of calling of the plumbing or licensed fire suppression piping establishment, where business mail and telephone calls are normally received, where customers and salesmen are interviewed and where the records of the business are kept.

(6) All the limitations and restrictions for the use of "Contractor's Establishment" as required by the Zoning Resolution shall apply to the "place of business" of a plumbing or fire suppression piping establishment where the office portion and the shop portion are at the same location.

(7) All the limitations and restrictions for the use of "Office" as required by the Zoning Resolution shall apply to the office portion of a plumbing or fire suppression piping establishment where its location is different than the shop location. The shop location must comply with the limitation and restrictions for the use of "Contractor's Establishment" as required by the Zoning Resolution.

(8) All the limitations and restrictions for the use of "Office" as required by the Zoning Resolution shall apply to the office of a business where no plumbing or fire suppression piping shop exists.

(g) *Master plumber's and master fire suppression piping contractor's license plates regulated.*

(1) The use of the license by the holder thereof shall be in accordance with §§26-138 and 26-141 of the Administrative Code.

(2) Only one plate and seal shall be issued to a Licensed Master Plumber or Licensed Master Fire Suppression Piping Contractor for a "place of business" the location of which is in a district permitted by the Zoning Resolution. (See §§19-01(f)(6), (7) and (8)).

(3) A Licensed Master Plumber or Licensed Master Fire Suppression Piping Contractor conducting a business shall display prominently to the public in the window of the "place of business" designated in his or her application or on a sign securely attached to the said premises, his or her full name with words "Licensed Plumber" or "Licensed Master Fire Suppression Piping Contractor" immediately thereunder. If the business is conducted under a trade name, or by a co-partnership or corporation, such trade name or co-partnership or corporation name shall be placed immediately above the full name or names of the licensee(s) conducting the business as provided by §26-148(f) of the Administrative Code.

(4) The plate shall be kept prominently displayed to the public at the "place of business" designated in the application. The plate shall not be transferred to another address without notifying the

Commissioner of Buildings and receiving his or her written approval thereof, nor shall it be transferred to or displayed in connection with any trade name, co-partnership or corporation of which the holder of such plate may become a partner or officer. Where the license is used by the holder thereof for or on behalf of a partnership, corporation or other business association as provided by §26-138 of the Administrative Code, documents shall be filed with the Commissioner of the Department of Buildings to indicate the control or voting capital stock of such partnership, corporation or other business association.

(5) A person retiring from the business or trade as a Master Plumber or Master Fire Suppression Piping Contractor or, in the event of the decease of a Master Plumber or Master Fire Suppression Piping Contractor, his or her legal representative shall immediately surrender the plate and license to the Commissioner of Buildings in accordance with §26-148(h) of the Administrative Code.

(6) A Licensed Master Plumber or Licensed Master Fire Suppression Piping Contractor to whom a plate has been issued and any corporation or partnership with which he or she is associated shall not loan, rent, sell, or transfer the privileges of such license and plate to any person for the performance of plumbing work in accordance with §26-138 of the Administrative Code.

(h) *Revocation, suspension, or cancellation of license.* The Commissioner of Buildings may at any time revoke or suspend the license of a Master Plumber or Master Fire Suppression Piping Contractor for cause as provided for by §26-151 of the Administrative Code.

§19-02 Continuing Education Requirements for Master Plumbers and Licensed Master Fire Suppression Piping Contractors.

(a) *Applicability.* This rule shall be applicable to the applicants seeking departmental approval to provide continuing education courses for master plumbers and master fire suppression piping contractors, as set forth in Administrative Code §26-150.1.

(b) The content of courses and qualifications of course providers shall be approved in accordance with the following. Course providers seeking approval by the Department of Buildings shall submit proposals in writing to the Department that include the following:

(i) Identification of the class(es) of licensees for which the proposed course(s) will be taught;

(ii) A proposed curriculum appropriate for the type(s) and class(es) of licensees to which the course(s) will be taught. All curricula shall include but not be limited to:

(a) Business practices;

(b) Relevant building code provisions, rules, policy and procedure notices, and reference standards enacted or promulgated by the Department in the twenty-four months prior to the individual course date(s);

(c) Department of Environmental Protection Water Rules;

(d) Department of Buildings filing and inspection requirements made effective by the Department in the twenty-four months prior to the individual course date(s);

(e) Safety/hazardous materials;

(f) New technology;

(g) Integrity/anti-corruption standards; and

(h) Other subjects identified by the Commissioner.

(iii) A schedule detailing the courses' proposed cost(s) to individuals and/or groups wishing to enroll;

Rules and Regulations

- (iv) A listing of the courses' proposed availability;
- (v) A detailed statement of the proposed provider's qualifications, including but not limited to instruction staff qualifications, other jurisdictions in which the provider has been approved to provide continuing education courses (if any), the composition of its governing authority, an identification of its administrative resources (physical and human), and documentation that demonstrates financial viability;
- (vi) A detailed statement of the proposed provider's procedures for confirming the identity of individuals taking any course(s) and for the issuance of a fraud-resistant document demonstrating that a licensee attended the course(s); and
- (vii) Such other items as the Commissioner of Buildings may deem appropriate and necessary.

(c) The Department of Buildings shall notify applicants of their approval in writing. Departmental approval of courses and providers shall expire on December thirty-first of every other year. Applicants for approval shall therefore submit applications on or before the first of November of the year approval is to expire.

§19-03. Exemptions from Inspection and Testing Requirements.

(a) Applicability. This rule shall be applicable to all plumbing and gas piping jobs for which inspection and testing is required pursuant to Administrative Code §27-919.

(b) Every new plumbing and gas piping system and every part of an existing system that has been altered, except for alterations involving ordinary repairs, shall, upon notification provided to the Department of Buildings pursuant to Administrative Code §27-920, be tested and inspected to determine compliance with Administrative Code requirements as set forth in Administrative Code §27-922. However, for jobs involving minor plumbing work as defined in paragraph (c) of this section, the Department of Buildings may accept written certification from a licensed Master Plumber that the job was performed in compliance with the requirements of the Administrative Code and any other relevant rules and regulations of the Department of Buildings in lieu of the notification and inspection requirements set forth in Administrative Code §§27-920 and 27-922.

(c) For the purposes of this section, "minor plumbing work" is defined as any of the following:

- (i) The removal of a domestic plumbing system not connected to a fire suppression system, or the removal of a portion of such system;
- (ii) The relocation of up to two plumbing fixtures that are a distance of no more than ten (10) feet from the original fixture, and within the same room, except in health care facilities, subject to paragraph (d) (i) below;
- (iii) The installation, replacement or repair of a garbage grinder, back flow preventer or sump pump, subject to paragraph (d) (i) below;
- (iv) The replacement of closet bends or shower bodies, subject to paragraph (d) (i) below;
- (v) The replacement of gas water heaters or gas fired boilers with a capacity of 350,000 BTU or less where the existing appliance gas cock is not moved, subject to paragraph (d) (ii) below; or
- (vi) The repair or replacement of any non-gas, non-fire suppression plumbing not longer than 10 feet inside a building, or connected piping previously repaired or replaced under this provision.

(d) Written certification that minor plumbing work conforms to applicable laws, rules, and regulations, as permitted pursuant to paragraph (b) of this section, shall be submitted in such a form and in such a manner as the Commissioner may require. Master Plumbers submitting such certification must provide such information as the Commissioner may require, including but not limited to:

(i) Where the certification is for the relocation of up to two plumbing fixtures, installation, replacement or repair of a garbage grinder, back flow preventer, or sump pump, or for the replacement of closet bends or shower bodies, a statement that any roughing and/or venting was done in compliance with code requirements.

(ii) Where the certification is for replacement of gas water heaters or gas fired boilers with a capacity of 350,000 BTU or less and the existing appliance gas cock is not moved, a statement that the chimney has been inspected.

§19-04 Master Plumber and Master Fire Suppression Piping Contractor License Board – Qualification Recommendations

(a) In accordance with section 26-134 and 26-144 of the Administrative Code, the commissioner authorizes the Master Plumber and Master Fire Suppression Piping Contractor License Board ("Board"), as part of its investigation of unlicensed practitioners, to examine the qualifications of applicants for Master Plumber and Master Fire Suppression Piping Contractor Licenses.

(b) The Board may investigate the nature and quality of the supervision Master Plumber and Master Fire Suppression Piping Contractors provided to license applicants and report to the commissioner regarding whether licensees and the people they supervised were performing lawful work in accordance with Sections 26-142 and 26-146 of the Administrative Code:

(1) in the design and installation of plumbing systems in the United States, under the direct and continuing supervision of a licensed Master Plumber as defined by Section 26-141(c) of the Administrative Code; and

(2) in the design and installation of fire suppression piping systems in the United States, under the direct and continuing supervision of a licensed Master Fire Suppression Piping Contractor as defined by Section 26-141(c) of the Administrative Code.

(c) The Board is authorized to require the applicant to provide the Board with any information pertaining to the plumbing and fire suppression trades in furtherance of the Board's investigation into improper or illegal practices.

(d) The Board is authorized to require an applicant to provide the Board with documentation in support of his or her application including, but not limited to, the following:

(1) payroll records, time cards, sign-in sheets, work orders, and assignment or route logs;

(2) notarized letters or sworn statements from supervising licensees stating the time period during

Rules and Regulations

which he or she supervised the applicant, the number of hours per week he or she supervised the applicant, the work the applicant performed for the licensee, and jobs where such work was performed; and

(3) such other documentation the Board deems appropriate.

(e) Based on the review of the documentation, and any testimony before the Board, the Board shall make its recommendation to the commissioner as to whether:

(1) license applicants designed and installed plumbing work under the supervision of a licensed Master Plumber or Master Fire Suppression Piping Contractor;

(2) the licensees who supervised each applicant did so in a lawful manner; and

(3) license applicants obtained sufficient experience as set forth in section 26-146 of the Administrative Code to qualify for a Master Plumber or Master Fire Suppression Piping Contractor license.

(f) Based on the documentation, and any testimony before the Board, the Board may refer improper or illegal activities to the Department's investigative units for further investigation and/or disciplinary action.

CHAPTER 20 PIPING SYSTEMS

§20-01 Witnessing Tests of Gas Piping Systems.

(a) Persons witnessing tests of gas piping systems in accordance with §27-921(b) of the Administrative Code, other than authorized plumbing inspectors of the Department of Buildings, shall be acceptable to the Commissioner of Buildings and shall meet the following prerequisites:

(1) Be either a registered architect, licensed professional engineer, licensed master plumber, or employee of a utility company; and,

(2) Have at least five years experience in inspection and testing of gas piping systems, or hold a current master plumbers license.

(b) The witnessing of the test in accordance with §27-921 and these rules shall be in person by the specifically designated person on the list maintained by the Commissioner. This authorization may not be delegated to anyone, nor can persons under his supervision witness the test in his behalf.

(c) Authorized persons on the list shall be required to maintain liability insurance of an amount acceptable to the Department.

(d) Failure of authorized persons to require compliance with law and these rules, and/or submission of a false statement will be grounds for immediate suspension or revocation of an authorized representative's authority to conduct inspections on behalf of the Department, and the immediate suspension of a Master Plumber License; be cause for immediate referral to the Division of Professional Conduct of the State Education Department, in the case of Architects or Engineers; and be cause for immediate referral to the Public Service Commission, in the case of utility companies.

(e) Reports of the inspections or tests are required to be submitted, and shall be made on forms acceptable to the Department.

(f) No reports shall be accepted for any installations for which a prior permit has not been previously obtained from the Department.

§20-02 High Pressure Steam Piping Systems.

These regulations shall apply to high pressure steam piping system which is defined as a system operating at a steam pressure of more than fifteen (15) psi. In the application of these rules and regulations, loops, bends or offsets of the piping shall not be considered expansion joints.

(a) Existing Systems.

The following requirements are applicable:

(1) All expansion joints, anchorage and guides which are presently not accessible to permit a complete visual inspection, shall be made accessible. Where the integrity of any shaft enclosure is impaired hereby, proper means shall be provided to maintain its integrity. All joints, including the joints so exposed, shall be inspected for any signs, visual or audible, of [sic] any escaping steam or condensation. Where there is evidence of such escaping steam in a bellows joint, immediate appropriate action shall be taken including expeditious replacement of the joint. If the escaping steam is immediately adjacent to a tenanted area, the occupants of this area shall be evacuated and shall not be permitted to return until the joint has been replaced or removed. In all cases, the joint shall be kept under intensive surveillance by the owner until such replacement or removal. In the event that the leak is progressive and has progressed to an extent as to present a hazard, the steam system or any part thereof serviced by the affected joint shall be shut down and the Department of Buildings shall be notified immediately. The Commissioner may waive the requirement for the exposure of the structural attachments to the building of the anchorage or guides upon the certification of a professional engineer to the effect that the exposure would impair a structural element of the building and specifying the basis on which he predicates his conclusion as to the adequacy of the structural attachments to the buildings of the anchorage or guides without such exposure. Upon exposure and initial inspection of the joints, the Commissioner shall be notified in writing by registered or certified mail. Such notification shall specify the type and location of the joints and the date inspected. The notification shall also contain the name of the person responsible for seeing that the inspections are made and properly recorded. Such inspections and exposure shall be made within two weeks from the effective date of this requirement. The initial inspection of the anchorage and guides shall be made within two months from the effective date of this requirement.

The Commissioner shall be notified in the same manner described above of any subsequent change of the person responsible for seeing that the inspections are made and records kept.

The notifications required in this paragraph shall be addressed to the Borough Superintendent of the Borough in which the system is located.

(2) Maintenance inspections.

(i) Expansion joints shall be inspected weekly.

(ii) The anchorage and guides shall be inspected annually. Exposure of the structural attachments to the buildings of the anchorages or guides shall not be required where the inspection reveals no improper movement or defects in the system.

(iii) A record of such inspections shall be kept by the person in charge of the mechanical equipment of the building or other qualified person designated by the owner and acceptable to the Commissioner. The records shall be available at the premises and subject to inspection by the Commissioner.

(3) No joint, anchorage or guides shall be repaired, replaced or relocated, unless and until an application has been filed and the approval of the Department is obtained. The application

Rules and Regulations

shall contain all pertinent information and shall be filed by a licensed professional engineer, knowledgeable as to high pressure steam piping systems. He shall be responsible for the controlled inspection of the proposed work in accordance with the approval of the Department. This provision shall not apply to the repacking of a slip or ball joint, however, records of such repacking shall be kept in the inspection records as hereinabove provided. When, in the opinion of the professional engineer, the requirement for prior approval by the Department of Buildings would create an imminent health or safety hazard, the professional engineer may permit the work to proceed without prior approval. In such cases, he shall, prior to the repair, replacement or relocation, notify by telephone the Borough Superintendent of the borough in which the building is located; and, if the emergency occurs at other than normal working hours, he shall notify the Emergency Section by telephone at 312-8298.[sic] This shall be followed up by the filing of the application and obtaining the approval specified above.

(4) The Commissioner, where he deems it necessary, shall require the replacement or relocation of any joints, guides or anchors. The Commissioner shall cause the joints in potentially hazardous locations such as those which are located adjacent to tenant occupied spaces to be relocated, unless means exist or are provided for eliminating the hazard.

(5) Applicability upon completion of new high pressure steam piping systems. Upon the completion of a new high pressure steam piping system and the approval of same by the Department, the rules relating to existing high pressure steam piping systems affecting maintenance requirements and the keeping of records shall apply.

(b) *New Systems.*

For the purpose of the application of these rules and regulations, the replacement of existing steam piping systems, the installation of a new system in existing buildings, as well as installations in buildings hereafter constructed, shall be considered to be new high pressure steam piping systems. The following requirements are applicable:

(1) Design.

(i) The system shall be designed by a registered architect or licensed professional engineer. An application and plans shall be filed and the approval of the Department obtained. The plans and application shall contain, but not be limited to the following information:

(A) Size and location of all steam piping.

(B) The operating pressures and temperatures.

(C) The location, type, specifications and details of all expansion joints.

(D) The design, size, material and location of all anchors, guides and auxiliary steel, and the stresses thereon.

(ii) Systems using utility street steam shall be designed for a pressure of 200 psig and 413^o [sic] F up to and including the steam pressure reducing valve or valves which reduce the pressure of 90 psig or below. For steam pressures between 90 psig and 16 psig the system shall be designed for 125 psig.

(2) *Installation.*

(i) Installations (including any welding for same), shall be under controlled inspection by the engineer responsible for the design, or by a Professional Engineer acceptable to him.

(ii) Systems using utility street steam shall be designed for a pressure of 200 psig and 413^o F up to and including the

steam pressure reducing valve or valves which reduce the pressure of 90 psig or below. For steam pressures between 90 psig and 16 psig the system shall be designed for 125 psig

(iii) Welders shall be qualified for all required pipe sizes, wall thickness and positions in accordance with the American Society of Mechanical Engineers, Welding and Brazing Qualification, Section IX, Boiler and Pressure Vessel Code

Rules and Regulations

This page is intended to be left blank.

Rules and Regulations

1980, (ANSI/ASME BPV- IX- 1980). Requalification is required every three years; or, if there is a specific reason to doubt the welders ability to make sound welds.

(iv) Welder qualification testing shall be performed by an agency listed with the Department of Buildings, and if the testing is by radiography, the inspection shall have a minimum radiography qualification of Level II in accordance with the American Society for Non-destructive Testing, 3200 Riverside Drive, Columbus, Ohio 43221, Recommended Practice, Document No. SNT-TC-1A- 1980.

(v) Copies of the certified welder qualification reports shall be maintained by the responsible welding agency and the company performing the welding, and shall be made available upon request to the Department of Buildings.

(vi) No reports from any welding inspection agency shall be accepted unless such agency has first requested and obtained from this Office [*sic*] in accordance with §25-01(q)(1) of the Board of Standards and Appeals Welding Rules.

(vii) (A) All piping over 3 inches shall be butt welded. Piping 3 inches and under may be socket welded or threaded.

(B) Threaded piping may continue to be used for existing construction in sizes of 6 inches and under.

(C) The Borough Superintendent may determine where welding is not feasible and that an acceptable alternative has been provided.

(viii) Radiographic examination, when required, shall be performed on butt welds in accordance with the following standard:

(ix) The percentage of butt welds subject to radiographic examination shall be based on the piping pressure and shall be as follows:

| AMSI/ASME B 31.1 - 1980 | |
|-------------------------|---------------|
| Piping Pressure | Percentage |
| 90 psig or below | Not required |
| 91 psig to 150 psig | 10% at Random |
| Over 150 psig | 100% |

However, if in the opinion of the engineer responsible for Controlled Inspection radiographic examination is not required for piping at pressure between 90 psig and 150 psig, he shall so specify in writing, and his final report on the installation may omit the foregoing, and be predicated on all of the other requirements noted above, as well as a hydrostatic test.

(x) Testing - Hydrostatic test the completed installation at 150 percent of the design pressure for all piping pressure. Where the changes in an existing steam system involve less than 30 percent of the piping in the system, the testing may be in accordance with the ASME Power Piping Code, (ANSI/ASME B 31.1 - 1980).

§ 20-03 Standards for Non-Mercury Gauges.

(a) *Applicability.* In accordance with Local Law 17 for the year 2001, the rules in this section establish minimum standards for non-mercury gauges to test gas piping, drainage and vent systems.

(b) *Minimum Requirements.* Each gauge shall meet the following requirements:

(1) The gauge shall be manufactured and used in accordance with the ASME B40.100-1998 Standard for Pressure Gauges and Gauge Attachments, which incorporates ASME B40.1-1998 and ASME B40.7-1998, and the manufacturer

shall provide with the gauge a written statement that the gauge is manufactured in accordance with such ASME standard,

(2) The gauge shall be labeled with the name of the manufacturer,

(3) The gauge shall be kept in a padded separate rigid box and the manufacturer's instructions for use and protection of the gauge shall be complied with,

(4) The units of measurement "psi" shall appear on the face of the gauge, and

(5) The gauge shall be kept in good working order.

(c) *Analog Gauges Used to Measure Pressure in the Magnitude of 3 psig.* Each analog gauge used to measure pressure in the magnitude of 3 psig shall meet the following requirements in addition to satisfying the minimum requirements set forth in subdivision (b):

(1) The face of the gauge shall not be smaller than 2¼ inches in diameter,

(2) The gauge shall have a minimum of 270-degree dial arc,

(3) The gauge shall be calibrated in increments of not greater than one-tenth of a pound,

(4) The range of the gauge shall not exceed 5 psig when a 2¼ inch diameter gauge is used,

(5) The 1/10th psig interval on the gauge shall not be smaller than 1/10th of an inch of arc,

(6) The gauge shall be provided with an effective stop for the indicating pointer at the zero point,

(7) The gauge shall be protected from excessive pressure with a shut off valve and prior to using the 5-psig gauge the snifter valve shall be tested with a tire gauge to determine the magnitude of pressure, and

(8) The gauge shall have a calibration screw.

(d) *Analog Gauges Used to Measure Pressure in the Magnitude of 5 psig.* Each analog gauge used to measure pressure in the magnitude of 5 psig shall meet the following requirements in addition to satisfying the minimum requirements set forth in subdivision (b):

(1) The face of the gauge shall not be smaller than 2¼ inches in diameter,

(2) The gauge shall have a minimum of 270-degree dial arc,

(3) The gauge shall be calibrated in increments not greater than one-fifth of a pound,

(4) The range of the gauge shall not exceed 10 psig when a 2¼ inch diameter gauge is used,

(5) The 1/5th psig interval on the gauge shall not be smaller than 1/10th of an inch of arc,

(6) The gauge shall be provided with an effective stop for the indicating pointer at the zero point,

(7) The gauge shall be protected from excessive pressure with a shut off valve and prior to using the 10-psig gauge the snifter valve shall be tested with a tire gauge to determine the magnitude of pressure, and

(8) The gauge shall have a calibration screw.

(e) *Digital Gauges Used to Measure Pressure in the Magnitude of 3 psig and Higher.* Each digital gauge used to measure pressure in the magnitude of 3 psig and higher shall meet the following requirements in addition to satisfying the minimum requirements set forth in subdivision (b):

(1) The gauge shall have a minimum reading of 1/100th of a psig, and

(2) An extra charged battery shall be readily available for immediate use with the gauge.

Rules and Regulations

CHAPTER 21 PLANS

§21-01 Limited Supervisory Check and/or Professional Certification Program for Applications and Plans.

(a) Definitions. For the purposes of this section, the following definitions shall apply:

(1) Architect. "Architect" shall mean a person licensed and registered to practice the profession of architecture under the education law of the state of New York.

(2) Engineer. "Engineer" shall mean a person licensed and registered to practice the profession of engineering and use the title "Professional, Engineer" and the initials "P.E." under the education law of the state of New York.

(b) Conditions of Limited Supervisory Check and/or Professional Certification. In accordance with §27-143 of the Administrative Code of the City of New York, the Commissioner may exercise his or her discretion in designating portions of the examination of applications and plans for the construction of new buildings or the alteration of existing buildings for limited supervisory check and/or professional certification predicated upon statements and representations made by the architect or engineer of record, and his or her associates where applicable, provided the following conditions are met:

(1) That complete and coordinated architectural, structural and mechanical plans are or have been filed.

(2) That, where applicable, the portion for limited supervisory check be clearly and specifically identified. However, such identified portion shall not include compliance with the zoning resolution nor the exit requirements of the building code or other applicable laws.

(3) That, where applicable, the necessary certifications and appropriate approvals have been obtained regarding the following topics or from the following agencies:

(i) Landmarks, landmark sites and historic districts.

(ii) Sewers.

(iii) Urban Renewal Areas.

(iv) Transit Authority for the effect on subways.

(v) Compliance with General City Law, Section 35.

(vi) Liability Insurance.

(vii) Board of Standards and Appeals.

(viii) Department of Environmental Protection.

(ix) Department of Housing Preservation and Development.

(x) Department of Transportation.

(xi) Fire Department.

(xii) Loft Board.

(xiii) Department of City Planning.

(xiv) U.S. Department of State.

(xv) Department of Cultural Affairs.

(xvi) Any other approval or certification of which the professional knows or should know is required prior to submitting an application.

(4) That the architect or engineer of record and associate architects or engineers, if any, are aware that the Commissioner, in the exercise of his or her discretion in accordance with §27-143 of the Administrative Code, will rely upon the truth and accuracy of the statements contained in the construction application made by them, and any amendments submitted in connection therewith, as to compliance with the provisions of the Zoning Resolution, the Building Code and other applicable laws and regulations.

(5) That the architect or engineer of record and associate architects or engineers, if any, shall comply with the provisions of the Zoning Resolution, the Building Code and other applicable laws and regulations or shall resolve any non-compliance as provided in paragraph 6, below.

(6) That, prior to the limited supervisory check and/or professional certification, any non-compliance shall be resolved by reconsideration or otherwise. Such reconsideration or other resolution shall be in writing and shall be submitted with the application that qualifies for limited supervisory check and/or professional certification.

(7) That, should Department audit indicate a non-compliance with the Zoning Resolution, the Building Code and/or other applicable laws and regulations, the architect or engineer of record shall take the necessary remedial measures to obtain compliance.

(8) That the owner is aware of the application and the conditions under which it is being submitted and agrees to comply with any requirement for remedial measures, if necessary.

§21-02 Exclusion from Limited Supervisory Check and/or Professional Certification Programs.

(a) *Grounds for exclusion.* The Commissioner may exclude an architect or engineer from the Department's programs for limited supervisory check and/or professional certification of applications, plans and removal of objections if the Commissioner finds that the architect or engineer has:

(1) Displayed negligence or incompetence with regard to, or lack of knowledge of, the Building Code, the Zoning Resolution, the Department's regulations, or other applicable laws, rules or regulations as demonstrated by plans, applications, certifications, or inspection reports submitted by the architect or engineer to the Department; or

(2) Submitted plans, applications, certifications or inspection reports to the City that were required to be prepared by the architect or engineer or under his or her supervision but that were not prepared by the architect or engineer or under his or her supervision; or engaged in conduct evidencing a delegation of professional responsibilities to a person where the architect or engineer knew or had reason to know that such person was not qualified, by training, by experience or by licensure, to perform them; or

(3) Knowingly or negligently made false or misleading statements on or knowingly or negligently falsified, altered or allowed a person under his or her control and/or supervision to falsify or alter any certificate, form, signed statement, application or report filed with the City, or knowingly or negligently failed to file a report or obtain any approval, certification, waiver or reconsideration required by law or the City or willfully impeded or obstructed such filing, or induced another person to do so; or

(4) Been convicted of a criminal offense where the underlying act arises out of the architect or engineer's professional occupation or business dealings; or

(5) Had knowledge that any project or application filed with the Department with which the architect or engineer is involved in any capacity was fraudulent or dishonest in character and failed to report such fraudulence or dishonesty to the Department, the Department of Investigation or other relevant authority; or

Rules and Regulations

- (6) Engaged in misconduct regarding his or her Department-issued Photo Identification Card; or
- (7) Engaged in any conduct related to any activity performed in connection with his or her profession that evidences a failure to comply with the provisions of Federal, State or local law, rules or regulations or a Department order or requirement; or
- (8) Impeded, obstructed or failed to cooperate with an investigation or inquiry of or failed to provide documents requested by the Commissioner or his or her designee or the Department; or
- (9) Made a material misrepresentation to persons not affiliated with the Department regarding the status of applications and/or plans filed with the Department; or
- (10) Altered, defaced or destroyed Department property, or removed Department property, including permitted folders, from Department premises; or
- (11) Offered or attempted to offer a bribe or unlawful gratuity to a Department employee or other public servant; or
- (12) Failed to maintain a copy of plans and/or related documents approved by the Department for six years after the applicant has been issued a letter of completion, a Certificate of Occupancy, or an application sign-off, whichever occurs later; or
- (13) Permitted the improper use of, or had knowledge of or failed to promptly report to the Department any improper use of his or her professional stamp, signature, or license number; or
- (14) Within a period of six months, failed two Department audits that resulted in revocations.

(b) *Procedures.*

(1) Administrative charges outlining the basis for such action to exclude from the limited supervisory check and/or professional certification program shall be served upon the architect or engineer by certified mail, return receipt requested, pursuant to the Office of Administrative Trials and Hearings' (OATH's) Rules of Practice (Title 48 of the Rules of the City of New York).

(2) Notwithstanding the foregoing, if the Commissioner finds that continued use of the programs for limited supervisory check and/or professional certification by the architect or engineer would likely create a serious and immediate threat to public safety or property, the Commissioner shall have the power, pending service of administrative charges, to issue an order immediately suspending the architect or engineer and his or her associates, if applicable, from limited supervisory check and/or professional certification.

(c) *Hearing.*

(1) Upon a filing of the administrative charges, the architect or engineer will be scheduled for a hearing upon submitting any written objections to the administrative charges and the grounds for such objections to the Commissioner within fifteen days after the date that the notice of charges is served.

(2) All hearings are to be held at OATH. The architect or engineer may be represented by counsel or by a duly authorized representative and may present evidence on his or her behalf.

(3) When the Commissioner suspends an architect's or an engineer's limited supervisory check and/or professional certification privileges pursuant to § 21-02(b)(2), the architect or engineer shall have fifteen days from the date the order is served to object and request a hearing on the order and any forthcoming administrative charges. The written objection shall include the grounds for such objection(s). Failure to make a timely objection shall result in a waiver of the right to a hearing and the Commissioner's order shall thereupon be considered a final determination. Upon receipt of a timely objection to the order, the Commissioner or his or her representative shall promptly schedule a hearing at OATH, with due consideration given to the current OATH calendar, and serve the architect or engineer with charges and notice of such hearing pursuant to OATH's Rules of Practice.

(4) After the conclusion of a hearing, the OATH Administrative Law Judge shall issue proposed findings of fact and proposed conclusions of law, along with a report and recommendation to the Commissioner. The Commissioner shall review the report and recommendation issued by the OATH Administrative Law Judge and shall issue a final determination. The Commissioner shall notify the architect or engineer in writing of the final determination. Such notice shall include a written statement indicating the reason for the final determination.

(5) After the Commissioner has rendered a final determination excluding a particular professional, all applications and plans submitted by that architect or engineer shall be subject to full review by the Department.

CHAPTER 22 PRESSURE TANKS

§22-01 Installation and Maintenance of Pressure Tanks Operating at a Pressure in Excess of 15 PSI and Their Proximity to Gas Supply or Service Lines.

(a) *Applicability.* These regulations shall apply to tanks containing water and air in combination, under pressure exceeding 15 psi above atmospheric pressure, where the pressure is supplied and maintained by pumps connected directly to the tanks.

b) *Design.*

The system shall be designed by a registered Architect or a Licensed Professional Engineer. An application and plans shall be filed and the approval of the department obtained. The plans and application shall contain, but not be limited to:

- (1) Size and location of high pressure tanks.
- (2) The operating pressures and temperatures.
- (3) The location, type and specifications of pressure relief valves.

(c) *Location.*

(1) All high pressure tanks shall be located a clear distance of

Rules and Regulations

at least five feet horizontally from a gas service or distribution line or its vertical projection upon the floor.

(2) All new high pressure tank [sic] installations shall be located in rooms separated from gas service or distribution lines.

(3) In cases where the spatial relationship between tanks and gas services does not comply with the regulations, it shall be the responsibility of the party responsible for the last installation to correct the violation.

(d) Installation.

(1) Installation with the exception of welding, shall be under controlled inspection by the engineer responsible for the design, or by a Professional Engineer acceptable to him.

(2) The welding shall be under controlled inspection of an Engineer, supervising a welding inspection agency acceptable to the Department of Buildings.

(3) Welders shall be qualified for all pipe sizes, wall thickness and positions in accordance with either the American Petroleum Institute, 1801 K Street, N.W., Washington, D.C. 20006, Standard for Welding Pipelines and Related Facilities, Fourteenth Edition, January 1977, (API STD 1104-1977), or the American Society of Mechanical Engineers, Welding and Brazing Qualification, Section VIII, Boiler and Pressure Vessel Code, 1980, (ANSI/ASTM BPV-IX-1980), and requalified on an annual basis.

(4) The qualification testing shall be performed by an agency listed with the Department of Buildings, and the inspector shall have a minimum radiography qualification of Level II in accordance with the American Society for Nondestructive Testing, 3200 Riverside Drive, Columbus Ohio 43221, Recommended Practice, Document No. SNT-TC-1A-1980.

(5) Copies of the certified welder qualification reports shall be maintained by the responsible welding agency and shall be made available upon request to the Department of Buildings.

(6) No reports from any welding inspection agency shall be accepted unless such agency has first requested and obtained approval from this Office, in accordance with Rule 2511(G)(1) of the Board of Standards and Appeals Welding Rules.

(7) All welded piping shall be butt welded.

(8) Radiography shall be performed on all butt welds in accordance with API STD 1104-1977 or ANSI/ASTM BPV-IX-1980.

(9) Testing- A hydrostatic test of the completed installation at 150 percent of the design pressure adjusted to compensate for the difference in gas or fluid pressure and the ambient temperature shall be conducted. Where the changes in an existing system incorporating high pressure tanks involves less than 30 percent of the piping system, the testing may be in accordance with Standard Power Piping, ANSI B31.1-1980.

CHAPTER 23 NONCOMMERCIAL GREENHOUSES

§23-01 Noncommercial Greenhouses Accessory to Residential Uses as a Permitted Obstruction in Required Rear Yards or Rear Yard Equivalents.

(a) *Definitions:* Greenhouse. A greenhouse shall be defined as a glass or slow burning plastic enclosed building used for cultivating plants.

(b) *Detached accessory noncommercial greenhouse.* A detached accessory noncommercial greenhouse is a permitted obstruction in a required rear yard or rear yard equivalent, pursuant to §23-44 (b) of the Zoning Resolution, when it

complies with the following conditions:

1. no portion of the greenhouse is located in a rear yard equivalent which also is a required front or side yard,

2. the greenhouse does not exceed ten feet above the level of the rear yard or rear yard equivalent,

3. the floor area of the greenhouse is included in the total floor area on the zoning lot,

4. the greenhouse use does not create offensive odors or dust,

5. the wall of the greenhouse closest to the appurtenant residential use building shall be a minimum distance of six feet from the exterior wall of such residential use building,

6. the greenhouse shall not be located less than 3 feet from a lot line,

7. the greenhouse shall be constructed of non-combustible materials and glazed with plain or wire glass or slow burning plastic,

8. the glass or slow burning plastic constructed roof shall be capable of supporting the live load prescribed in §27-561 (a) of the Building Code.

(c) *Attached accessory noncommercial greenhouse.* An attached accessory noncommercial greenhouse is a permitted obstruction in a required rear yard or rear yard equivalent, pursuant to §23-44 (b) of the Zoning Resolution when it complies with the following conditions:

1. no portion of the greenhouse is located in a rear yard equivalent which also is a required front or side yard, 2. the greenhouse roof shall be no higher than the level of the floor above the lowest residential level,

3. the floor area of the greenhouse is included in the total floor area on the zoning lot,

4. the greenhouse use does not create offensive odors or dust,

5. in no event shall the greenhouse project more than six feet from the plane surface of the building wall,

6. the greenhouse shall be constructed of noncombustible materials and glazed with plain or wire glass or slow burning plastic. The floor of the greenhouse shall be constructed as required in Table 3-4 of the Building Code, for the construction classification of the building to which it is attached and if not on grade [sic] shall be capable of sustaining a minimum live load of 75 pounds per square foot,

7. the roof of the greenhouse shall be constructed of glass or slow burning plastic and capable of supporting the live load prescribed in §27-561(a) of the Building Code,

8. the depth of the greenhouse need not be included in the maximum permitted depth of a room, pursuant to §30(3) of the Multiple Dwelling Law,

9. the greenhouse shall be provided with operable windows or жалюзи, whose free openable area shall be equal to at least five percent of the combined floor area of the greenhouse, as prescribed in §27-750 of the Building Code.

CHAPTER 24 REFUSE CHUTES AND REFUSE ROOMS

§24-01 Construction and Maintenance of Refuse Chutes and Refuse Rooms.

(a) *Refuse chute enclosures.* Refuse chutes used for conveyance of garbage and rubbish from upper floors of a building to a cellar or other location shall be constructed with an enclosure of brick masonry at least eight inches in thickness or of reinforced concrete at least six inches in thickness, except as

Rules and Regulations

otherwise provided in this section.

(b) *Height and service openings.* Refuse chutes shall extend from the refuse collection room to a height of at least six feet above the roof. A spark arrestor shall be provided at the top of the chute above the roof. Service openings into the chute shall be equipped with approved self-closing hoppers so constructed that the chute is closed off while the hopper is being loaded and so that no part will project into the chute. The area of service opening shall not exceed one third the area of the chute. Hopper doors shall have a fire resistive rating of at least one hour, unless separated from the corridor by a fireproof, self-closing door in which case they shall be constructed of incombustible material.

(c) *Existing flues and refuse chutes.* Flues for existing incinerators may be used for refuse chutes provided such flues are in good condition and provided the flues comply with the provisions of subdivisions (a) and (b) of this section. Existing refuse chutes may be continued in use provided they conform to the provisions of subdivisions (a) and (b) of this section, except that existing refuse chutes of other construction, which have been approved by the Department may be retained.

(d) *Refuse chutes in new construction.* Where refuse compacting systems are required hereafter in new construction, refuse chutes shall be required for conveyance of garbage and rubbish to refuse collection rooms, except that refuse chutes will not be required in class A multiple dwellings which are four stories or less in height. Refuse chutes erected hereafter in new construction shall be of a type approved by the board or shall comply with the requirements of subdivisions (a) and (b) of this section. Chutes shall be constructed straight and plumb, without projections of any kind within the chute. Refuse chutes shall have an inside dimension of at least twenty-four inches for the full height of the chute. All chutes shall be supported on fireproof construction having at least a three hour resistive rating.

(e) *Refuse collection rooms.* A refuse collection room shall be provided at the bottom of all chutes at the cellar or lowest story level to receive the refuse. Such rooms shall be enclosed with walls and roofs constructed of material having a minimum fire resistive rating of three hours, except that gypsum masonry may not be used for such enclosure walls. Openings to such rooms shall be provided with fireproof, self-closing doors having a minimum fire resistive rating of one and one-half hours. It shall be unlawful to keep such doors open. Refuse chutes shall extend to the underside of the roof of the refuse room or lower. Roofs shall be at least six inches away from combustible floor or wall construction. Refuse rooms shall be used only for receipt of refuse and for refuse compacting equipment. Refuse rooms shall be provided with sufficient sprinklers to sprinkle all parts of the room, with at least two sprinkler heads provided and with sprinklers so separated as to sprinkle a maximum area of the room when one of the sprinklers is blocked or not operating. A hose connection shall be provided within the refuse room. Existing refuse rooms and incinerator rooms that have been approved by the Department for such use may

Rules and Regulations

This page is intended to be left blank

Rules and Regulations

(f) *Collection room floors.* The floor within the room for the collection of refuse shall be constructed of concrete and shall be sloped to a floor drain within the room connected to the house drain. The drain shall be provided with a protective screen to retain solid material. Floor drain traps shall be readily accessible for cleaning.

(g) *Use of existing combustion chambers.* Existing incinerator combustion chambers may be used in whole or in part as refuse collecting rooms for collection of refuse and for compacting equipment provided the grates are removed and provided they comply with the provisions of subdivision (e) of this section.

(h) *Sprinkler operation and water supply.* Sprinklers shall be designed to operate automatically at a temperature not exceeding one hundred sixty-five degrees Fahrenheit. They may be electrically controlled provided such sprinklers are approved by the Board of Standards and Appeals. Sprinklers may be connected to the cold water supply of the building at the point where such service enters the building or at the base of a water supply riser provided the piping of such service or riser is of adequate size. No connections, except those for sprinklers, shall be made to the sprinkler piping.

(i) *Hoppers, cut off doors and compactors.* A hopper and cut off door shall be provided at the bottom of the refuse chute to regulate and guide the flow of refuse into containers. Where compactors are installed so that the refuse flows directly into the compacting equipment, the equipment may be used in place of the hopper and cut off door. Compacting equipment shall be arranged to operate automatically when the level of rubbish is not higher than three feet below the lowest door.

Compactors shall be located entirely within the enclosure of the refuse room and former combustion chamber where the latter is retained, except that motors, pumps and controls may be installed in adjacent rooms.

Where refuse is removed manually, the refuse shall be removed with sufficient frequency so that it will at no time extend less than three feet below the level of the lowest hopper door opening into the chute.

(j) *Number of sprinkler heads.* Sufficient sprinklers shall be installed in the refuse room and former combustion chamber to provide sprinkler coverage for the entire area of each unit.

(1) Adequate lighting shall be provided in refuse rooms.

(2) Refuse chutes, refuse rooms, hoppers and all parts of the refuse collecting system shall be maintained in a clean and sanitary condition at all times, free of vermin, odors and defects, and shall be maintained in good operating condition. Fused sprinkler heads shall be replaced promptly.

(3) The owner shall establish a program to ensure that the refuse chute and the refuse room and appurtenances will be treated as often as may be necessary to prevent infestation with insects or rodents. The owner shall maintain a record of such treatments which shall be available at all times for inspection by the Department.

(k) These rules shall apply only to refuse chutes in new construction and to refuse chutes resulting from the conversion of existing incinerator flues and to existing refuse chutes.

(l) *Collection and disposal of refuse within premises.* The collection and disposal of refuse within any building or on any premises shall be performed as deemed necessary to provide for the safety, health and well being of the occupants

of buildings and of the public. The construction, operation, maintenance, cleanliness and sanitation of refuse chutes and refuse rooms and extermination treatment for insects and rodents, and the keeping of records of such treatments for refuse chutes and refuse rooms shall be in accordance with regulations established by this Department in consultation with the Department of Health.

CHAPTER 25 CLIMBER AND TOWER CRANE RIGGERS

§25-01 Licensing Persons as Climber or Tower Crane Rigger.

(a) *Qualifications.* Applicants shall meet the following qualifications at the time of filing for the license:

(1) Be able to read, write and speak the English language.

(2) Be able to interpret structural and erection drawings.

(3) (i) Have at least five years of supervisory experience within the last 10 years in the planning and execution of the erection or dismantling of tower and climber cranes; or

(ii) For a period of five years within the last 10 years, an applicant shall have erected or dismantled, as part of a team, eight or more tower and/or climber cranes of which at least three erections and dismantlings of such cranes shall be under his supervision, and/or oversee the safety and code requirements for the same.

(b) *Prerequisites to examination.* Applicants shall be required to have passed a written and practical examination no more than one year prior to the application filing date. Prior to being eligible to take such examination, an applicant must submit satisfactory evidence that:

(1) the applicant has at least five years of supervisory experience in the planning and execution of the erection or dismantling of tower or climber cranes; or

(2) the applicant has at least five years of practical experience working as part of a team erecting and dismantling tower or climber cranes and has participated in at least eight such erections or dismantlings.

(c) *Annual renewal of licenses without examination.* Licenses issued under the above stated rules may be renewed annually without examination.

(d) *Requirement of examination following failure of timely renewal.* Failure to renew this license annually shall require an examination or re-examination as appropriate. Renewal applications shall be submitted between 30 and 60 days prior to the expiration date of the license.

(e) *Fees.* The initial fee for licensing in accordance with these rules shall be \$150.00, and the annual renewal fee shall be \$50.00. If the initial application is denied, a refund of \$50.00 will be made.

CHAPTER 26 SAFETY OF PUBLIC AND PROPERTY DURING CONSTRUCTION OPERATIONS

26-01 Filing of Site Safety Programs and Designation of Site Safety Managers.

(a) *Program to be filed.*

(1) No permit shall be issued for:

(i) the construction of a major building (as hereafter defined); or

(ii) for the alteration of the facade of a major building when a sidewalk shed is required by §27-1021(a)(5) of. The site

Rules and Regulations

safety program shall be submitted after the Administrative (Building) Code, until a document describing a site safety program has been filed at the borough office approval of the building application has been obtained, but before approval of any full or partial permit. If partial approval and partial permit are being sought (e.g. foundation, excavation or the like), then the scope of the site safety program shall reflect that component of work.

(2) A major building is a building either:

- (i) 15 or more stories;
- (ii) 200 feet or more in height;
- (iii) with a lot coverage of 100,000 square feet or more regardless of height; or
- (iv) as designated by the commissioner of the Department of Buildings.

(b) *Manager to be designated.* The site safety program shall provide for the designation of a site safety manager, certified by the Department of Buildings.

(c) The Department of Buildings shall issue a site safety manager certificate to an individual who shall have good moral character so as not to adversely impact upon his or her fitness to perform the duties and responsibilities of a site safety manager, and the following qualifications:

(1) (i) New York State Licensed Professional Engineer or Registered Architect, or eight years of construction supervision experience, including five years of such experience with major buildings, and

(ii) Proof that, within the year prior to the date of the application for certification, the person has satisfactorily completed an orientation course approved by the Department of Buildings of no less than five hours in duration and passed a written examination covering Subchapter 19 of Chapter 1 of Title 27 of the Administrative (Building) Code and the duties of site safety manager; or

(2)(i) Completion of an on-the-job training program under a currently certified site safety manager. Such training shall cover all aspects of the site safety management and all phases of building construction, from the commencement of construction until the building is completely enclosed, and shall last a minimum of 18 months. Each month the site safety manager shall summarize the trainee's activities in the site safety log or other record, and shall certify as to the trainee's satisfactory completion of the training program; and

(ii) Proof that, within the year prior to the date of the application for certification, the person has satisfactorily completed 40-hour course approved by the Department of Buildings and passed a written examination covering Subchapter 19 of Chapter 1 of Title 27 of the Administrative Code and the duties of a site safety manager.

(d) Certificates shall be renewable every three years, provided that the certificate holder shall have good moral character so as not to adversely impact upon his or her fitness to perform the duties and responsibilities of a site safety manager, and shall have satisfactorily completed a seven (7) [sic] hour site safety course approved by the department within one (1) year prior to the renewal date.

(e) Effective October 1, 1987, all individuals, whether previously approved or currently designated as site safety managers or alternates, must hold a site safety manager certificate from the Department of Buildings. All incumbents who

do not hold a certificate as of that date shall be disqualified from the position.

(f) *Responsibility for site safety.* Nothing in these rules is intended to alter or diminish any obligation otherwise imposed by law on the owner, construction manager, general contractor, contractors, materialmen, architects, engineers, or other party involved in a construction project to engage in sound engineering, design and construction practices and to act in a reasonable and responsible manner to maintain a safe construction site.

(g) *Site Safety program and manual.* (1) The site safety program shall include the duties of the site safety manager and the measures to be taken to ensure compliance with the safety requirements of Subchapter 19 of Chapter 1 of Title 27 of the Administrative (Building) Code.

(2) The site safety manager shall monitor compliance with the safety requirements of Subchapter 19 of Chapter 1 of Title 27 of the Administrative (Building) code, but shall not be responsible for reviewing design specifications, lifting capacities, performing technical inspections, etc. (except as such duties may fall within the scope of other responsibilities of such person).

(3) The specific duties and responsibilities of the site safety managers are described in the Department of Buildings' Manual for Site Safety Programs, which appears as an appendix to this rule.

(i) the manual may not be changed or modified by the Department of Buildings without first obtaining comment from the Building Industry Advisory Council of the Department of Buildings or representative organizations for the construction industry.

(i) The manual shall be an appendix to these rules and regulations.

(ii) The manual shall be available at the offices of the Department of Buildings.

(4) The site safety program to be submitted pursuant to this section shall contain statements from both the contractor and the site safety manager and alternate managers, if any, that the manager and alternates will have those duties and responsibilities as described in the manual and that the contractors' policy is as set forth in the manual. The site safety program shall include a site safety plan, which shall have descriptions of the following items, including approximate dates of installation, where applicable:

(i) location of all construction fences around job site;

(ii) location of all gates in fences;

(iii) location of guardrail around excavation during excavation, when required;

(iv) horizontal and vertical safety netting program, including details of the initial installation, a schedule of horizontal jumps and vertical installations, and designated crane and derrick lifting areas where the horizontal netting is to be omitted;

(v) location of sidewalk sheds;

(vi) location of temporary walkways;

(vii) location of footbridges and motor vehicle ramps;

(viii) protection of side of excavation, when required;

(ix) location of street and sidewalk closing(s);

(x) approximate location of material and personnel hoist(s) and loading areas;

(xi) approximate location of all crane and derrick loading

Rules and Regulations

areas;

(xii) location of surrounding buildings, indicating occupancy, height and type of roof protection, when required; location of standpipe system and siamese hose connections; location of temporary elevators for fire department use when building is above 75 feet in height; location of all exterior contractors' sheds; safety netting and scaffolding when required by §27-1022 of the Administrative Code; sidewalk and roadway widths and all traffic information and all exits from job sites; specific case reconsiderations in relation to requiring safety netting during construction operations are to be attached and the revised site safety plans shall be approved.

(h) *Signs at construction sites.* In addition to the information required to be displayed on signs at construction sites specified in §27-1009(c) of the Administrative Code, the telephone numbers of the following shall be prominently displayed in both English and Spanish:

The Department of Buildings

The Building Enforcement Safety Team (B.E.S.T.)

The Emergency Squad

The Department of Transportation

(i) *Fees.* The initial fee for obtaining certification as a site safety manager in accordance with these rules shall be \$300.00, and the renewal fee shall be \$150.00.

(j) Other than as required by statute or pursuant to these rules or as set forth in 1 RCNY §27-03, there shall be no information, pictorial representations, or any business or advertising messages posted on the sidewalk shed or bridge or other structure listed [sic] in §26-252(a) of the Administrative Code of the City of New York which is erected at the construction site and is adjacent to such building.

(k) Where renewal for an application for a sidewalk shed or other protective structure listed in §26-252(a) of the Administrative Code of the City of New York and pursuant to §27-1021 of the Administrative Code is required, such application must be signed by the owner of the affected building.

§26-02 Safety Netting During Construction Operations.

(a) *Applicability.* Safety netting shall be provided on the sides of a structure more than six stories or seventy-five feet in height above the adjoining ground or adjoining roof level, whichever is applicable, when there is exposure to the public or adjacent property. Reference to OSHA Safety and Health Standard 29 CFR 1926.500 is suggested.

(1) While under construction, the facade of such structure is not enclosed. In such case:

(i) Horizontal safety netting shall be provided pursuant to §27-1021(a)(6) and §26-02(e)(3) of these rules.

(ii) Vertical safety netting shall be provided pursuant to §27-1021(a)(7) and §26-02(f)(4).

(2) When demolishing the exterior walls or roof of a structure. In such case: Horizontal safety netting shall be provided pursuant to §27-1022(a)(1) and §26-02(e)(3)(ii).

(3) When exterior walls are being constructed. In such case: Horizontal safety netting shall be provided pursuant to §27-1022(a)(2) and §26-02(e)(3)(iii).

(b) *Definitions.*

Debris Netting. "Debris netting" shall mean netting of a fine mesh of a size and strength sufficient to catch debris such as falling tools and materials.

Enclosed.

(i) "Enclosed" shall mean a structure is enclosed when the permanent facade is completed except for the windows.

(ii) Such windows shall be protected to a height specified in §26-02 (f)(3) unless there is a sill not less than two feet-six inches in height and vertical mullions or piers with a maximum opening of five feet and a non-corrosive wire cable which is capable of withstanding a load of at least two hundred pounds applied in any direction (except upward).

Exposure to the public or adjacent property. "Exposure to the public or adjacent property" shall refer to any unenclosed facade of [sic] a structure which is opposite a street, public way or other open areas intended for public use or which is opposite any side or rear lot line.

Horizontal safety netting.

(i) "Horizontal safety netting" shall mean a horizontal system of nets and their supports, as cited and modified in Building Code Reference Standard RS 19-4.1.

(ii) "Horizontal safety netting" shall include a structural net lined with a debris net of a size and strength sufficient to catch falling tools and materials.

Protected. "Protected" shall mean a structure is protected when there is temporary vertical netting.

Public or adjacent property. "Public or adjacent property" shall mean property which is protected as used herein in relation to "public or adjacent property" as required by Article Seven of Subchapter Three of Title Twenty-six of the Administrative Code.

Qualified person. "Qualified person" shall mean a person trained and qualified in a manner satisfactory to the holder of the work permit.

Structural netting. "Structural netting" shall mean a system of nets capable of complying with the prototype test described in Section Seven of Reference Standard RS 19-4.

Vertical safety netting.

(i) Vertical safety netting means a vertical system of nets and their supports, as cited and modified in Building Code Reference Standard RS 19-4.

(ii) Vertical safety netting shall be of a fine mesh of a size and strength sufficient to contain falling tools and materials.

(iii) Wall opening screens, grills or tarpaulins may be used in lieu of vertical safety netting, provided that they shall be structurally equivalent and of such construction and mounting installed so as to retain debris.

(c) *General requirements.*

(1) Structural net hardware shall be drop forged, pressed or formed steel or material of equal or better quality. Surfaces shall be smooth and free of sharp edges. All hardware shall have a corrosion resistant finish capable of withstanding a fifty hour salt spray test in accordance with ASTM B-1117.

(2) *Identification of nets.* Each structural net shall be permanently labeled with the following information:

- (i) Name of manufacturer
- (ii) Identification of net material
- (iii) Date of manufacture [sic]
- (iv) Date of prototype test
- (v) Name of testing agency
- (vi) Serial number

(3) *Inspection.*

- (i) Structural nets, including mesh ropes, hardware, connectors,

Rules and Regulations

suspension systems, shall be completely inspected by the manufacturer or manufacturer's representative or other qualified person after each installation. Additional inspections shall be made after relocation, alterations, repair, impact loading and welding or cutting operations above the nets.

(ii) Nets that show mildew, wear, damage or deterioration that substantially affects their strength shall be immediately removed from service and replaced.

(4) *Records to be maintained.*

(i) An on-the-job up-to-date [*sic*] record shall be maintained for the structural portion of each horizontal net. The record shall include the following information:

Net serial number

Date installed

Dates inspected and all removal orders, per §26-02(c)(3)(ii).

The qualified person responsible for the nets shall initial each entry.

The information required by this rule shall be recorded as part of the Site Safety Log, where such log is required.

(ii) A letter or other documentation from the manufacturer stating the description, model or serial number of all vertical netting shall be kept posted until all such netting is removed.

(5) *Care, maintenance and storage.*

(i) Care, maintenance and storage of nets shall be in accordance with the net manufacturer's recommendations with due attention being given to the factors affecting net life.

(ii) Debris shall be removed from nets at least daily.

(iii) Nets shall be capable of a minimum service life of two years under normal on-the-job exposure to weather, sunlight, and handling, excluding damage from misuse, mishandling and exposure to chemicals and airborne contaminants.

(6) *Storage of materials.* Safety netting shall not be used for storing materials.

(7) *Combustibility.* The debris netting shall be noncombustible or flame-resistant.

(d) *Precautions.*

(1) *Sunlight.* Ropes one-half inch in diameter and smaller shall be treated to resist damage from the sun's rays. All nets not in use should be protected from direct and indirect sunlight.

(2) *Abrasion.* Dragging or chafing of nets over the ground or other rough surfaces shall be minimized in order to protect against abrasions and prolong life.

(3) *Sand.* Care shall be taken to keep nets as clean and free of sand as possible.

(4) *Rust.* Nets shall not be stored in metal containers that are rusty. Net hardware shall be replaced if there is evidence of heavy corrosion.

(5) *Welding and cutting operations.* Nets and debris shall be protected from sparks and hot slag resulting from welding and cutting operations or other operations producing sparks or excessive heat.

(e) *Horizontal safety netting.*

(1) *Design, testing and installation requirements.* Horizontal safety netting shall be designed, tested and installed in accordance with Reference Standard RS 19-4, as modified.

(i) *Structural mesh openings.* Mesh openings should be small in order to spread the deceleration force through as many net strands as possible. The maximum size of mesh shall not exceed thirty-six square inches or be longer than six inches on any side measured center-to-center of mesh ropes

or webbing, and center-to-center of mesh crossing. All mesh crossings shall be anchored to eliminate frictional wear and prevent enlargement of the mesh opening.

(ii) *Debris netting openings.* The largest opening area for fine mesh netting when used horizontally shall not be larger than one-half square inch.

(iii) *Deceleration and rebound force.* Design, materials and construction shall combine to produce a net which will minimize a deceleration and rebound force.

(iv) *Connections.* Connections between net panels shall develop the full strength of the net.

(2) *Projection of safety netting.* Horizontal safety netting shall project outward horizontally from the edge of the floor a minimum distance of ten feet.

(3) *Locations where required.*

(i) Horizontal safety netting shall be maintained not more than two stories below the stripping operation floor on concrete structures or the uppermost finished (and walkable) concrete floor on steel frame structures, provided that such floor is more than six stories or seventy-five feet in height above the adjoining ground or adjoining roof level, whichever is applicable.

(A) *Stripping operation.* The stripping operation on concrete structures shall not be performed more than three stories below the story being formed.

Note: Industrial Code Rule 23 of the State of New York (12 NYCRR 23-2.4 (a)) states:

"23-2.4 Flooring requirements in building construction. (a) Permanent flooring and skeleton steel construction in tiered buildings. The permanent floors of such buildings or other structures shall be installed as soon as possible as the erection of structural steel members progresses. In no case shall there be more than eight stories, floors or equivalent levels or 120 feet, whichever is less, between the erection floor and the uppermost permanent floor".

(B) *Tarpaulins.* When tarpaulins encase one or more floors immediately below the finished concrete floor in order to maintain temporary heat, the horizontal nets may be located no more than three floors below the finished concrete floor.

(C) The installation of the horizontal safety nets shall not interfere with Fire Department access from the street.

When [*sic*] demolishing the exterior walls or roof of a structure horizontal [*sic*] safety netting shall be constructed and maintained not more than two stories or thirty feet below the story from which the exterior walls and roof are being removed until the demolition has progressed to within six stories or seventy-five feet off [*sic*] the ground or adjoining roof level.

(A) An exterior built-up scaffold conforming to Article eight of Subchapter nineteen of the Building Code may be used in lieu of horizontal safety netting.

(B) The horizontal safety netting or scaffolding shall be required in addition to the sidewalk sheds, fence or railings required under §27-1021 of the Administrative (Building) Code.

(iii) Constructing exterior walls from a scaffold. Horizontal safety netting shall be constructed and maintained not more than two stories or thirty feet below the story from which the exterior walls are being constructed, or the bottom, outer faces and ends of the scaffold shall be enclosed with debris netting or its equivalent so as to prevent the falling of material and debris.

(iv) Designated crane and derrick lifting areas. The

Rules and Regulations

horizontal safety netting required by §§26-02(e)(3)(i)(ii) and (iii) may be omitted in designated crane and derrick lifting areas so long as it is as indicated on the crane application and on the site safety program.

(v) Horizontal safety netting may be removed after the formwork for the topmost level of concrete is removed or after the topmost level of concrete for a steel building is poured.

(f) *Vertical safety netting.*

(1) *Design and installation requirements.* Vertically installed nets or screens shall be supported so as to be capable of withstanding a load of at least two hundred pounds applied at any direction (except upward).

(2) *Debris netting openings.* The largest opening area for fine mesh netting when used vertically shall not be larger than one square inch.

Debris netting purchased prior to November 3, 1987 may be installed until January 2, 1988 and may remain for the duration of construction with openings up to five and one-half square inches. Such netting may not be used to replace tow boards as provided in §26-02(f)(5).

(3) *Height of safety netting.* Vertical safety netting shall have a height not less than sixty inches in buildings more than six stories or seventy-five feet in height.

Vertical safety netting purchased prior to November 3, 1987 may be installed to a height of not less than forty-two inches until January 2, 1988 prior to which time additional netting to a height of not less than sixty inches shall be installed.

(4) *Locations where required.*

(i) Vertical safety netting shall be provided on the sides of a structure more than six stories or seventy-five feet in height above the adjoining ground or adjoining roof level.

(ii) Vertical safety netting shall be maintained at each story except at the story at grade, the story immediately above the sidewalk shed and the roof level where a parapet is installed.

Until elevator in readiness is operative for Fire Department access, such netting shall not be installed below the sixth story or seventy-five feet in height.

(iii) Vertical safety netting shall be secured and kept closed at all times except during actual loading operations or perimeter construction operations.

(5) The top edge and intermediate height of nets shall be mounted securely to non-corrosive wire cable capable of withstanding a load of at least two hundred pounds applied to any direction (except upward).

(6) Toe boards, required by subdivision (b) of §27-1050 of the Administrative Code shall not be necessary if the netting is brought to deck level and securely fastened and has openings not over one inch in greatest dimension.

(g) *Responsibility.* The holder of the work permit and his/her designee shall be responsible for the installation and maintenance of all horizontal and vertical netting, and for complying with these rules and regulations.

(h) *Appeals.*

(1) Requests for New York City Building Code Information, Interpretations, Consultations and Reconsiderations shall be in accordance with Paragraph four of Directive one of 1985. The Commissioner may, in specific cases, modify these rules and regulations where proper methods are proposed to be employed.

(2) *Site Safety Program.* The appeal shall make reference to the Site Safety Program where applicable, when stating the specific relief requested, the practical difficulty, proposed equivalencies consistent with public safety to be complied with and any stipulations.

(i) *Accidents pertaining to public and adjacent properties.*

(1) *Borough office.* The Borough Office of the Department of Buildings shall be notified of all accidents at construction sites at telephone numbers provided in the City's website, <http://www.nyc.gov>.

(2) The Building Enforcement Special Team (BEST Squad) shall be notified of any accidents relative to buildings fifteen or more stories and two hundred feet or more in height at the telephone number provided in the City's website, <http://www.nyc.gov>.

§26-03 Storage of Materials During Construction.

(a) *Applicability.* Pursuant to subdivisions (c), (d) and (e) of §27-1018 of the Administrative Code of the City of New York, materials stored on the floors of a building during construction operations shall comply with these rules and regulations.

(b) *Housekeeping.*

(1) When not being used, materials, equipment and tools that might fall from levels above areas used by the public shall be kept away from edges or openings.

(i) When exterior walls are not in place, stored material shall be kept at least ten feet back from the perimeter of the building.

(ii) However, when the floor area is less than one thousand square feet, stored material may be kept not less than five feet back from the perimeter of the building.

(iii) Material may be stored between five feet and ten feet back from the perimeter of the building when such material weighs [*sic*] less than seven hundred-fifty pounds.

(2) Material stored on floors of a building shall be secured when not being used.

(c) *Storage of materials at top working floors.*

(1) Material may be stored to within two feet of the edge of the building on the upper working floors located not more than two stories below the stripping operation on concrete structures or on the uppermost concrete floor on steel structures.

Such material shall be secured against accidental movement such as by winds and vibration from adjacent moving loads or load carriers.

(2) No material shall hang over the edge of a building unless banded and braced preparatory to relocation at the end of the workday.

(i) Where such material is so banded and braced, it may overhang the floor of the stripping operation by not more than one-third of its length so long as it is relocated on the next workday for concrete operations.

(ii) Where the steel mill and lumber mill are located on not more than two additional floors, material may overhang for relocation until the next workday.

(d) *Debris.*

(1) All debris shall be cleaned off floors daily.

(2) The roof of the sidewalk shed and the street shall be cleaned of construction debris daily.

(3) A daily inspection shall be made for construction debris on all floors and if a major building noted in the site safety log.

Rules and Regulations

(e) *Waste dumpsters, debris boxes and skip boxes.*

(1) Waste dumpsters, debris boxes and skip boxes shall be secured from movement by rope, cable or chocking at wheels at the end of the workday.

(2) Containers containing debris or waste shall be covered at the end of the workday and when full to near the rim.

(3) Containers need not be covered when not in use or while stored in a fully enclosed space at the end of the workday.

(f) *Containers for the storage of debris.*

(1) Sufficient containers of metal, canvas, plastic or other material acceptable to the commissioner shall be available.

(2) The containers shall be of three-quarter cubic yard minimum capacity.

Containers of one-half cubic yard minimum capacity may be used so long as the total capacity of the containers at the construction site is not less than that required by this subdivision (f)(2).

(3) The Commissioner may accept alternate container sizes to function with the building's size.

§26-04 Use of Reshores During Construction Operations.

(a) *Applicability.* Pursuant to subdivision (f) of §27-1035 of the Administrative Code, reshoring shall be provided where forms and shores are stripped before concrete has gained adequate strength to support the superimposed loads due to construction above. Paragraph (1) of subdivision (f) specifies a prohibition on the use of wedges within ten feet of a facade and such other locations as determined by rules and regulations.

(1) *Definition.* Shores are defined as vertical or inclined falsework supports.

(2) *Stripping.* Removal on the floor of any parts of the concrete formwork including shoring, bracing and other supports shall be considered as stripping.

Waste debris as a result of stripping operations shall be immediately contained and removed at reasonable intervals.

(b) *Formwork.*

(1) *Form design drawings.* Form design drawings shall be available to the Commissioner as per subdivision (c) of §27-1035.

(2) *Records.* Records shall be available for inspectors per subdivision (b) of §27-1035.

(c) *Installation limitations - reshores.*

(1) Reshores shall be perpendicular to the surface which they are supporting.

(2) Reshores of wood or metal shall be screw adjusted or jacked and locked and wedged to make them secure.

(3) Wedges shall not be used within ten feet of the facade of a building.

(4) Adjusting devices shall not be used if heavily rusted, bent, dented, rewelded or having broken weldments or other defects.

(5) Metal shoring and accessory parts shall be fully operative when in use.

(6) Reshores within ten feet of the facade of a building shall be secured to prevent them from falling off the building.

(d) *Specific safety provisions.*

(1) Extra shores or material and equipment that might be needed in an emergency shall be furnished.

(2) Care shall be taken while stripping is underway to insure that material does not fall off the building.

(3) Building materials shall be properly piled and tied or contained.

The Department of Buildings Manual for Site Safety Programs May, 1988

A. Purpose.

This "Manual" outlines the requirements of the site safety programs submitted to the Department of Buildings pursuant to Local Law 45 of 1983, Local Law 61 of 1987 and the rules and regulations relating to the filing of site safety programs, dated September 23, 1986, as set forth in Subchapter 19 of Chapter 1 of Title 27 of the Administrative (Building) Code. The requirements include a schedule of specific duties and responsibilities for the site safety manager and other items that are to be set forth in a site safety program. They are not intended, however, to supersede any requirements of the Building Code, or rules and regulations promulgated by the Buildings Department or any other city, state or federal agency, pertaining to site safety and other construction activity.

B. Scope.

Site Safety program requirements shall apply to all construction projects that have the following scope of work:

1. The construction of a major building, which is defined as either 15 or more stories, or 200 feet or more in height.

2. 100,000 square feet or more of lot coverage regardless of height.

3. The alteration of the facade of a major building, when a sidewalk shed is required.

4. As designated by the Commissioner of the Department of Buildings.

C. Designation of Site Safety Manager.

In accordance with §27-1009 of the Administrative (Building) Code, unless otherwise determined by the Commissioner, it shall be the responsibility of the builder/owner, agent, the construction manager or the general contractor (the "Contractor") to designate a construction site safety manager who must be present on a construction site for those projects that are within the scope of this program, as defined above, and who shall be responsible for all site safety requirements as specified in the site safety program and Subchapter 19 of Chapter 1 of Title 27 of the Administrative Code.

In the event that an alternate manager will be acting as the full-time safety manager for a period longer than two weeks, the Department of Buildings must be so notified. Any permanent change of site safety manager requires immediate notification of the Department of Buildings.

D. Site Safety Manager Qualifications.

Individuals eligible for designation as site safety manager shall meet one of the following requirements: (1, 2, or 3).

1. a. New York State Licensed Professional Engineer or Registered Architect, or a person with eight years of construction supervision experience including five years of such experience with major buildings, and

b. Certification that the person has satisfactorily completed an orientation course approved by the Department of Buildings of no less than 5 hours in duration and passed a written examination given by the N.Y.C. Department of Personnel covering Subchapter 19 of Chapter 1 of Title 27 of the Administrative Code, [sic] and the duties of site safety manager as detailed in Local Law 45 of 1983; or

2. a. Satisfactory equivalent of experience and/or education, as determined by the N.Y.C. Department of Personnel, and

b. Certification that the person has satisfactorily completed a

APPENDIX A

Rules and Regulations

40-hour course approved by the Department of Buildings and passed a written examination given by the N.Y.C. Department of Personnel covering Subchapter 19 of Chapter 1 of Title 27 of the Administrative Code and the duties of a site safety manager; or

3. a. Completion of an on-the-job training program under a currently certified site safety manager. Such training shall cover all aspects of site safety management and all phases of building construction, from the commencement of construction until the building is completely enclosed, and shall last a minimum of 18 months. Each month, the site safety manager shall summarize the trainee's activities in the site safety log or other record, and shall certify as to the trainee's satisfactory completion of the training program; and

b. Certification that the person has satisfactorily completed a 40-hour course approved by the Department of Buildings and passed a written examination given by the N.Y.C. Department of Personnel covering Subchapter 19 of Chapter 1 of Title 27 of the Administrative Code and the duties of a site safety manager.

4. All individuals approved by the Department of Buildings as site safety coordinators prior to July 1, 1985 shall be required to complete the 40 hour orientation course and pass the written examination given by the N.Y.C. Department of Personnel, but shall not be subject to the Personnel Department's subsequent review of qualifications.

5. Site Safety Manager Certificates shall be issued by the Department of Buildings in accordance with the regulations relating to the filing of site safety programs. A copy of the Site Safety Manager Certificate for the proposed site safety manager (and alternate manager, if any), shall be included with the contractor's submission of its site safety program. No proposed alternate manager shall have as his or her primary duty the job of site safety manager on any other construction project.

E. Statement of Contractor's Policy.

1. The Contractor agrees that it shall appoint a qualified site safety manager who shall be assigned the responsibilities described in the Contractor's site safety program submitted to the Department of Buildings pursuant to Local Law 45 of 1983. The site safety program will incorporate the provisions of this site safety manual as required as per §26-01(d) of the Rules and Regulations of the Department of Buildings, effective [September 23, 1986.]*

*** Copy in brackets not enacted but probably intended.**

The contractor also agrees that it shall notify all of its supervisory personnel and all of its subcontractors working on the construction site of the name and responsibilities of the site safety manager.

It shall state to its directly employed personnel and also to its subcontractors that the site safety manager is responsible for monitoring compliance with the Buildings Department regulations dealing with site safety and that they are required to obey and implement all orders and directives relating to safety requirements.

2. The contractor also agrees to inform the site safety manager that, in the event he or she discovers a violation of the site safety regulations, he or she should immediately notify the person or persons responsible for creating the violation, whether these persons are employed by the Contractor or by subcontractors. If the site safety manager is unable to obtain the cooperation of these persons in correcting the violation, he or she will be

instructed to inform his or her direct supervisor immediately and request that the supervisor order the necessary corrective action. If the supervisor of the site safety manager is not present at the site or otherwise available, the site safety manager will be told to notify any other supervisory personnel of the Contractor present on the job or any other responsible manager or officer of the Contractor.

F. Contractor's Responsibility.

It shall be the responsibility of all general contractors, construction managers and subcontractors engaged in building work to institute and maintain safety measures and provide all equipment or temporary construction necessary to safeguard the public and property affected by their operations.

G. Site Safety Manager's Responsibility.

1. In addition to other safety duties assigned by the owner or contractor to meet the federal and state requirements, it shall be the responsibility of the site safety manager to monitor compliance with the safety requirements of Subchapter 19 of Chapter 1 of Title 27 of the Administrative (Building) Code. At a minimum, this requires that the manager, as a representative of the owner, his agent, the general contractor and/or construction managers, meet on a weekly basis with the designated representative of each subcontractor to ascertain that they are complying with the provisions of Subchapter 19 of Chapter 1 of Title 27 of the Administrative Code when the scope of the subcontractor's work at that time falls within the Subchapter.

2. The site safety manager shall immediately notify the Chief Inspector of the Building Enforcement Special Team directly if he/she discovers any of the following in the routine performance of the job:

- a. a person is operating a crane, derrick or hoisting equipment on the construction site without a permit and refuses to desist from operating the crane;
- b. that crane is being operated by an unlicensed operator and said unlicensed operator refuses to desist from operating the crane;
- c. no flagmen present during crane operation where required by the Building Code;
- d. sidewalk sheds required by the site safety plan are not in place during construction activity;
- e. permits have not been issued for the sidewalk sheds;
- f. the designer and/or supplier of sidewalk sheds has not certified that the sheds have been erected in accordance with the approved plans;
- g. an accident involving the public, or private or public property has occurred.

3. Upon proper notification of the Department of Buildings of the existence of any of the above noted circumstances, any liability the site safety manager has or may have under the Building Code arising out of, relating to, or as a result of the existence of that circumstance, shall cease.

4. It shall be the responsibility of the site safety manager to inspect personally, on a regular basis, specific areas and items, identified below, and to notify responsible personnel employed by the general contractor, construction manager or any subcontractor when violations of Subchapter 19 of Chapter 1 of Title 27 of the Administrative Code or the Subchapter 19 Site Safety Program have occurred.

5. The site safety manager shall ensure that all daily entries

Rules and Regulations

in the site safety log are completed. These entries must be recorded by 7:00 a.m. on the day following the activities.

6. An example of a log sheet and permit log are attached as Appendix A and B.

7. The site safety manager, or alternate, shall sign the log at the beginning of each day, and must be present at the job at all times during ongoing construction. If at any point during the day the site safety manager, or alternate, shall be relieved of his/her responsibilities at the construction site, or leave the site for any reason he/she shall indicate this in the log, and an alternate shall sign in.

8. The site safety manager shall make periodic inspections of the construction site in accordance with the schedule in the following chart to determine that the conditions at the site meet the public safety requirements of Subchapter 19 of Chapter 1 of Title 27 of the Administrative Code.

H. Items to be recorded in Site Safety Log.

1. Details of areas inspected by the site safety manager.
2. Companies and representatives met with weekly to ascertain their Subchapter 19 compliance.

I. Periodic Site Safety Inspections.

1. General Requirements for Site Safety

| Construction Sites | Minimum Schedule of Inspections |
|---|--|
| a. When the building reaches a height greater than 75 feet at least one elevator or personal hoist with an emergency communication system shall be kept available for use at all times as per Fire and Building Department requirements. | As appropriate |
| b. When the personnel hoist requires a jump, all necessary permits must be obtained and testing performed. | As appropriate |
| c. When the building reaches a height greater than 75 feet, a standpipe system shall be available and in readiness at all times for Fire Department [<i>sic</i>] use. <ol style="list-style-type: none"> 1. Valves shall be in place at each story below construction floor. 2. Standpipes shall be connected to water source and siamese connection. 3. Siamese hose connections shall be kept free from Obstruction and shall be marked by a sign reading, "Standpipe Siamese Connection," and by a red light. | Daily As appropriate Periodic Daily |
| d. The construction shed shall be constructed of noncombustible materials if located within 30 feet of the building. | Once per shed |
| e. Interior and exterior guard rails and toeboards shall be provided and properly installed to meet the standards as described in the Administrative (Building) Code §27-1050. | Daily |
| f. All openings and/or holes in the floor must be covered at all times. | Daily |
| g. All stairwells must have standard handrails. | Daily |
| h. Each sign as required in the Administrative (Building) Code §27-1009(c) shall also contain the telephone number of B.E.S.T. and the Emergency Squad. | Once per sign |
| 2. Safety Netting. | |
| a. Horizontal safety netting shall be maintained not more than two stories below the stripping operation floor on concrete structures or uppermost finished and walkable concrete floor on steel frame structures, providing that such floor is more than six stories or such floor is seventy-five feet in height above the adjoining ground or adjoining roof level, whichever is applicable. | Daily |
| b. Horizontal safety netting shall project outward horizontally From the edge of the floor a minimum distance of ten feet. | Daily |
| c. The horizontal safety netting may be omitted in designated crane and derrick lifting areas as it is indicated and approved on the crane application and on the site safety plan. | Weekly |
| d. For steel frame construction where the steel frame extends more than eight | Daily |

Rules and Regulations

- stories above the walkable concrete floor, vertical safety netting shall be provided at the floors at and below the topmost working metal deck, where this deck is substantially completed and the required guard rails and toeboards are in place.
- e. Vertical safety netting shall be provided at all floors below the floor on which horizontal netting is required. Daily
 - f. Vertical safety netting shall be maintained at each story except for the story at grade, the story immediately above the sidewalk shed and the uppermost level. Daily
 - g. Vertical safety netting shall be secured and kept closed at all times except during actual loading operations or perimeter construction operations. Daily
- 3. Maintenance of site and adjacent areas.**
- a. Guards, shields or barricades shall surround all exposed, electrically charged, moving or otherwise dangerous parts of machines and construction equipment so as to prevent contact with the public. Daily
 - b. There shall be no exposed hose lines, wire, ropes etc., that may constitute a tripping hazard to the public. Throughout day
 - c. Adjoining property shall be protected when the height of building exceeds that of adjoining property. Daily
 - d. If the building is erected, enlarged or increased in height so that any portion of such building, except chimneys or vents, extends higher than the top of any previously constructed chimneys within 100 feet the chimneys must be made to conform with §27-860 of the Administrative Code. As Appropriate
- 4. Housekeeping.**
- a. All areas used by the public shall be maintained free from ice, snow, grease, debris, equipment, materials, projections, tools or other items substance or conditions that may constitute a slipping hazard. Throughout day
 - b. Floors and stairs shall be cleaned [sic] of excess debris. Throughout day
 - c. [sic] When not in use, equipment and tools shall be kept away from edges or openings. Throughout day
 - d. [sic] The roof of the sidewalk shed and the street shall be cleaned of debris. Daily
 - e. [sic] Sufficient containers for the storage of garbage and debris shall be in place. Daily
 - f. [sic] Containers shall be covered when full and secured. Daily
- 5. Removal and storage of material.**
- a. Combustible waste material or combustible debris shall be removed from the site. Daily
 - b. Chutes, when used for the removal of debris, shall be installed and maintained in accordance with §27-1019 of the Administrative Code. Weekly
 - c. When exterior walls are not in place, stored material shall be kept at least ten feet back from the perimeter of the building. If the floor area is less than one thousand square feet, stored material may be kept not less than five feet back from the perimeter of the building. Daily
 - d. Material stored on floors of a building shall be secured when not being used. Daily
 - e. Material may be stored to within two feet of the edge of the building only on the upper working floors located not more than two stories below the stripping operation on concrete structures or on the uppermost concrete floor on steel structures. Daily
 - f. No material shall hang over the edge of a building unless banded and braced preparatory to relocation prior to the end of the workday. Daily
 - g. Where such material is so banded and braced it may overhang the floor of the stripping operation by not more than one-third of its length so long as it is relocated by the next workday for concrete operations. Daily
 - h. Where the steel mill and lumber mill are located, material may overhang for relocation until the next workday. Maximum number of floors designated as steel mills [sic] or lumber mills [sic] is two. Daily
- 6. Protection of sidewalks.**
- a. Permits for sidewalk sheds shall be in effect and posted in a central, visible area. Periodic
 - b. Approved drawings of the sidewalk shed shall be at the construction site. Periodic
 - c. The designer and/or supplier of sidewalk sheds shall certify that such sheds have been erected in accordance with the approved plans and that a Form B-23 has been filed with the Department of Buildings. Once

Rules and Regulations

- | | |
|---|---|
| <p>d. Sidewalk sheds shall remain in place until the structure is enclosed, all exterior work completed, the sash is glazed above the second story, the exterior of the facade is cleaned down, all outside handling of material, equipment and machinery is completed and dismantling of a material hoist, tower or climber crane, or the use of a derrick in their removal above the second story, is completed.</p> | <p>Weekly</p> |
| <p>e. All openings in sidewalk sheds, fences and railings for loading purposes shall be kept closed, barricaded, protected or guarded at all times.</p> | <p>Throughout day</p> |
| <p>f. Sidewalk sheds shall extend the entire perimeter of the building.</p> | <p>Once</p> |
| <p>g. When the building exceeds 100 feet in height, sidewalk sheds shall extend 20 feet beyond the side property line.</p> | <p>Once</p> |
| <p>h. Sidewalk sheds shall be illuminated at night by the equivalent of 100-watt bulbs spaced 15 feet apart at a minimum height of 8 feet above floor.</p> | <p>Daily</p> |
| <p>i. Any temporary footbridges and walkways for the public shall be maintained at a width of at least 4 feet.</p> | <p>Daily as appropriate</p> |
| <p>7. Warning signs and lights.</p> | |
| <p>a. All dangerous and hazardous areas to the public or areas where work is performed near vehicular traffic shall be marked appropriately with warning signs and lights.</p> | <p>Daily</p> |
| <p>b. Other steps necessary to protect the public shall be taken, including provisions for flagmen whenever intermittent operations are conducted on or across areas open to the public or when dangerous operations, such as blasting, may affect such areas.</p> | <p>Throughout day as appropriate</p> |
| <p>8. Scaffolds, structural ramps, runways and platforms.</p> | |
| <p>a. Where it poses a risk to the public all structural ramps, scaffolds, runways and platforms shall be provided with standard rails, toeboards, screening, or nets, unless otherwise specified in the Building Code [sic].</p> | <p>Daily</p> |
| <p>9. Material handling and hoisting equipment.</p> | |
| <p>a. Certificates of approval, operation and on site inspection for all cranes, derricks and/or cableways shall be obtained and available for inspection at the construction site.</p> | <p>As required</p> |
| <p>b. Permits for highway and street closings shall be available at the construction site.</p> | <p>As required</p> |
| <p>c. Licenses of crane operators shall be available at the construction site.</p> | <p>Daily</p> |
| <p>d. Cranes shall be jumped, as needed, in accordance with the schedule submitted by the professional engineer and approved by the Department of Buildings.</p> | <p>As Appropriate</p> |
| <p>e. A means of communication shall be arranged and put into effect between the responsible parties when the operator of hoisting machinery has no vision of the lift or loading areas</p> | <p>Daily when operational</p> |
| <p>f. A program shall be established and operational for the control of pedestrian and/or vehicular traffic around the construction site during all lifting and hoisting operations.</p> | <p>Daily when operational</p> |
| <p>g. Flagmen shall be required to stop pedestrian and/or vehicular traffic during the following intermittent operations:</p> <ol style="list-style-type: none"> 1. All lifting and hoisting operations; 2. Trucks entering and exiting site; 3. Materials being lifted over sidewalk shed; 4. Dangerous operation, e.g., blasting; 5. When sidewalk and/or street is temporarily closed. | <p>As Appropriate</p> |
| <p>10. In addition to the above schedule, the site safety manager shall use reasonable prudence to ensure that safety is maintained at the job site as job conditions and Contractor's Statement of Policy dictate.</p> | |
| <p>J. General notes for site safety plan.</p> | |
| <p>Site Safety plans at a minimum shall include the following:</p> <ol style="list-style-type: none"> 1. Location of all construction fences around job site; 2. Location of all gates in fences; 3. Location of guard rail around excavation during excavation, when required; [sic] 4. Horizontal and vertical netting program, including details of the initial installation, schedule of horizontal jumps and vertical installations, and designated crane and derrick lifting areas where horizontal netting is omitted; | <ol style="list-style-type: none"> 5. Location of sidewalk sheds;¹ 6. Location of temporary walkways;¹ 7. Location of foot bridges and motor vehicle ramps;¹ 8. Protection of side of excavation, when required;¹ 9. Location of street and sidewalk closing(s);¹ 10. Approximate location of material and personnel hoist(s) and loading areas;¹ 11. Approximate location of all crane and derrick loading areas;¹ 12. Location of surrounding buildings, indicating occupancy, |

Rules and Regulations

noncombustible enclosure having a fire-resistance height and type of roof protection, when required;

13. Location of standpipe system and siamese hose connections;
14. Location of temporary elevators for Fire Department use when building is above 75 feet in height;
15. Location of all exterior contractors' sheds;
16. Safety netting and scaffolding when required by §27-1022 of the Administrative Code;
17. Sidewalk and roadway widths and all traffic information and all exits from job site;
18. Specific case reconsiderations in relation to requiring safety netting during construction operations are to be attached and the revised site safety plan shall be approved.

1. Indicate appropriate Department of Buildings application numbers and/or Department of Transportation permit numbers and expiration dates.

NOTE: Location of cranes-derricks and hoists, etc. may be entered on site plan as indicated on the Department of Buildings application and number by the Site Safety Manager and signed by the inspector when checked against the Department of Buildings application number during inspection.

CHAPTER 27 SIGNS

§27-01 Stair and Elevator Signs in Buildings Which Have at Least One Elevator.

(a) *Applicability.*

These rules and regulations shall apply to all buildings which have at least one elevator including:

- (1) Any existing office buildings occupied or arranged to be occupied for an occupant load of more than one hundred (100) persons above or below the street level or more than a total of five hundred (500) persons in the entire building, and
- (2) All other existing buildings which have at least one elevator, pursuant to §27-390 of the Administrative (Building) Code, as enacted by Local Law 16 of 1984.

(b) *Signs at elevator landings.*

(1) *Elevator landing sign.* On all floors other than the main entrance floor, a sign shall be posted and maintained on every floor at the elevator landing. The sign shall read "IN CASE OF FIRE, USE STAIRS UNLESS OTHERWISE INSTRUCTED".

(2) *Floor diagram sign.* The sign shall contain a floor diagram showing the location where it is posted and the location and letter identification of the stairs on the floor and each elevator bank.

(3) *J-2 multiple dwellings.* The floor diagram sign may be omitted on all residential floors in J-2 multiple dwellings provided that:

- (i) The stair is in the line of sight from the elevator call button, and
- (ii) The stair is located a maximum of twenty (20) feet from the elevator call button, and
 - (A) There is not more than one stair, or
 - (B) Two scissors stairs, or
 - (C) A stair or fire escape serves only an individual apartment and directional signs with arrows and reading "TO STAIRS" are provided.

(c) *Location.* The sign(s) shall be located:

- (1) Directly above the call button, and
- (2) Its top shall not be above six (6) feet from the floor level.
- (3) The sign(s) may be placed on the wall or an adjacent conspicuous place where there is insufficient wall space at the call button, or
- (4) The sign(s) may be placed on the elevator door(s) where

there is insufficient wall space or an adjacent conspicuous place at the elevator landing.

Exception: Raised signs on horizontal sliding flush type elevator doors.

(d) *Floor number sign(s).* Floor numbering sign(s) shall be posted and maintained within each stair enclosure on every floor. The floor numbering sign shall be posted and maintained on the stair side of the door, or if no door, nearby on the wall or an adjacent conspicuous place.

(e) *Stair and elevator identification signs.* Each stair and each bank of elevators shall be identified by an alphabetic letter. A sign indicating the letter of identification for the elevator bank shall be posted and maintained at each elevator landing directly above or as part of the sign specified in §27-01(b). The stair identification signs shall be posted and maintained on the occupancy and stair sides of the door, or if no door, nearby on the wall or an adjacent conspicuous place.

(f) *Stair re-entry signs.* Stair re-entry signs shall be posted and maintained on the stair door at each floor in buildings classified in Occupancy Group E, occupied or arranged to be occupied for an occupant load of more than a total of 500 persons in the entire building indicating re-entry is provided. The signs shall be attached approximately five feet above the floor. The signs shall read as follows and may be either independent or combined with the corresponding sign required by §§27-392 and 27-393:

(1) Where no re-entry is provided:

(i) Where no re-entry is provided from the stairs to any floor, the sign shall read "NO RE-ENTRY FROM THIS STAIR" and such sign shall be posted and maintained on the occupancy side of the stair door at each floor. No re-entry sign shall be required on the stair side of the door.

(ii) On every floor where fail-safe [*sic*] re-entry locking devices are installed on exit doors, a sign reading "NO RE-ENTRY FROM THIS STAIR EXCEPT DURING FIRE OR EMERGENCY" shall be posted on the occupancy side of the stair door.

(2) Where re-entry is provided to specified floors:

(i) On the stair side of the door at floors where re-entry is provided, the sign shall read "RE-ENTRY ON THIS FLOOR".

(ii) Where no re-entry is provided on that floor, the sign on the stair side of the door shall read, "NO RE-ENTRY, NEAREST RE-ENTRY ON THE AND FLOORS". The floor numbers of the nearest re-entry below and the nearest re-entry floor above shall be entered in the blank spaces

(g) *Size of signs.*

(1) Signs for new buildings shall be limited to combined elevator landing and floor diagram signs, conforming with paragraph (4) below. Signs for existing buildings in Occupancy Group J-2 may be either independent signs as required or combined signs, conforming with the size requirements as set forth in the following subdivisions.

(2) *Elevator landing signs.* Elevator landing signs shall be at least two and one-half (2 1/2) [*sic*] inches by ten (10) inches.

(3) *Floor diagram signs.* Floor diagram signs shall be at least eight (8) inches by twelve (12) inches.

(4) *Combined elevator landing and floor diagram signs.* Combined elevator landing and floor [*sic*] diagram signs shall be at least ten (10) inches by twelve (12) inches.

(h) *Lettering and coloring of signs.*

- (1) Lettering and background shall be in contrasting colors.
- (2) Lettering shall be of bold-type and properly spaced to provide good legibility.
- (3) The lettering and numerals of the signs shall be at least one-half inch high, except that:

(i) Floor numbering sign numerals shall be at least three inches high.

Rules and Regulations

(ii) Elevator identification sign letters shall be at least three inches high.

(i) *Material for signs.*

(1) Signs shall be of metal or other durable materials.

(2) Fire resistive pressure sensitive vinyl decals may be permitted if the plastic is printed on the reverse side.

(j) *Attachment of signs.* Signs shall be securely attached to the wall or partition.

(k) *Signs in existing buildings.*

(1) Signs installed prior to March 27, 1984 may be accepted by the Commissioner, provided that such signs will adequately accomplish the intended purpose.

(2) In buildings existing prior to March 27, 1984, the Commissioner may modify the requirements as to location of signs where compliance would cause practical difficulty or undue hardship.

(3) All existing buildings not already subject to the requirements of Local Law 5 as of January 18, 1983 shall comply with these requirements on or before October 1, 1985.

(l) *Compliance date.* Signs shall be installed on or before October 1, 1985.

(m) *Report of compliance.* Owners shall file a report with the Department of Buildings certifying that they have posted the signs in compliance with the Building Code requirements on or before October 1, 1985.

§27-02 Caution Sign Tapes Required on Elevators Being Serviced.

(a) In all buildings, when an automatic passenger elevator is being serviced by an elevator maintenance company, elevator maintenance personnel or other persons and there are no maintenance personnel available to remain in the elevator car, "CAUTION" sign tapes shall be placed across the car door jamb. One strip of "CAUTION" sign tape shall be placed at a height of eighteen (18) inches from the car floor and another strip of "CAUTION" sign tape shall be placed at a height of fifty-four (54) inches above the floor.

(b) The "CAUTION" sign tape shall be three (3) inches in width with the words "CAUTION - DO NOT ENTER" repeated every six (6) inches. The lettering shall be black on yellow background. The letters shall be at least two (2) inches high.

§27-03 Signs on any Sidewalk Shed, Fence, Railing, Footbridge, Catch Platform, Builder's Sidewalk Shanty, and Over-the-Sidewalk Chute Erected at Demolition or Construction Sites.

(a) *Applicability.* These rules and regulations shall apply to all protective structures erected at demolition or construction sites, including but not limited to, sidewalk sheds, fences, railings, footbridges, catch platforms, builder's sidewalk shanties, and over-the-sidewalk chutes as specified in Administrative Code §26-252(a).

(a) Other than the signs required by 1 RCNY §§8-01 and 26-01 or as set forth below, there shall be no information, pictorial representations, or any business or advertising messages posted on such protective structures at demolition or construction sites.

(c) *Required shed sign.* Where a sidewalk shed is erected and a sign is posted in compliance with Administrative Code §27-1021(a)(1)(b), the information shall also include the Department of Buildings' Complaint Telephone Number and whether the shed is a heavy duty sidewalk shed or light duty sidewalk shed as defined in 1 RCNY §8-01(a)(2). If the shed is for light duty use, the sign shall include the statement that storage is not permitted on the shed.

(d) *Signs.* A sign may be posted on such protective structure when the structure is adjacent to any building and obscures from view a lawful and existing sign and shall comply with the following requirements:

(1) Signs shall be securely fastened to the face of the protective structure at a location directly in front of such business storefront;

(2) No projecting signs shall be permitted, and all signs shall be limited to a maximum height of three feet six inches and when affixed to a sidewalk shed, shall not project above the parapet;

(3) No signs shall be permitted on the ends of any protective structure, unless the lawful and existing sign would otherwise be obscured from view by a deck or parapet of a sidewalk shed or bridge; and

(4) No sign shall project below the deck of any sidewalk shed.

(e) *Materials.* Such signs shall be constructed of three-fourths inch plywood or sheet metal.

(f) *Area and height limitations.* The maximum height for the erection of such sign shall comply with the applicable zoning regulations, statutes and these rules, and in no event shall the height of such sign be greater than three feet six inches.

(g) *Non-illumination.* No illuminated signs shall be permitted on any protective structure subject to this rule.

§27-04 311 Advisory Signs Required on Construction Sites.

(a) *Applicability.* Pursuant to subdivision (a) of Section 27-1009 of the Administrative Code, at least one sign shall be placed at any site of construction for which a New Building or Demolition permit is required. Such sign(s) shall contain the words "TO ANONYMOUSLY REPORT UNSAFE CONDITIONS AT THIS WORK SITE, CALL 311" (referred to herein as a "311 advisory sign") in both English and Spanish.

(b) *Location.* 311 advisory signs shall be placed at a height no more than twelve feet above ground and shall be prominently placed on each perimeter of a construction site fronting on a public thoroughfare.

(c) *Visibility.* The letters on 311 advisory signs shall be black on white background and be no less than six inches high.

CHAPTER 28 SMOKE DETECTING DEVICES AND SYSTEMS AND CARBON MONOXIDE DETECTING DEVICES AND SYSTEMS

§28-01 Required Smoke Detecting Devices and Systems.

(a) *Applicability.* (1) Local Law 62 for the year 1981 requires that all existing dwelling units within Occupancy Group J-1 (which includes Hotels, Motels, Lodging Houses, and Rooming Houses) and Occupancy Group J-2 (which includes Apartment Houses, Apartment Hotels and School Dormitory Buildings), and new buildings or substantially improved or altered buildings in Occupancy Group J-1, J-2 and J-3 (the latter includes One and Two Family Dwellings, Rectories, Convents and Group Homes) to be equipped with approved smoke detecting devices, except such units which contain operational automatic wet sprinkler systems.

(2) The devices shall be operational in existing Occupancy Groups J-1 and J-2 by January 1, 1982; however, the Commissioner may upon good cause shown extend the period of compliance to June 30, 1982. Appeals to the Commissioner for extension of the period of compliance shall be set forth on a form to be available and filed at the Office of the Commissioner, (Attention: The Executive Engineer), Department of Buildings, 60 Hudson Street New York, N.Y. 10013, [sic] no later than December 1, 1981, and contain the following information:

(i) The location of the premises, block and lot, the Building Department Application number, if any, the Construction and Occupancy Class, number of dwelling units, estimated number of detectors, type, and where they are to be installed.

Rules and Regulations

(ii) The hardship to be considered with regard to the delivery or installation of the equipment.

(iii) The proposed time table for compliance.

(iv) A copy of the signed contract for the purchase and/or installation of the system. (Cost figures may be deleted).

(v) The application number, as appropriate.

(3) The Commissioner will not consider "good cause" appeals unless:

(i) The installation is wired into the building's electrical system, or

(ii) The number of units in single ownership or management responsibility exceed 500, and a complete schedule for installation is submitted prior to January 1, 1982, or

(iii) Special circumstances not covered by subdivisions (i) or (ii) above are involved.

(4) Notice of approved extensions are to be forwarded to the Commissioner of the Department of Housing Preservation and Development.

(5) The requirements for new buildings within Occupancy Group J-3 and new or substantially improved or altered buildings in Occupancy Group J-1, J-2, or J-3, shall only apply to those for which plans are Approved by the Department of Buildings on or after January 1, 1982.

(b) *Installation—new, existing and altered buildings.* (1) Dwelling units shall be equipped with smoke detecting devices receiving their primary power from the building wiring, and there shall be no switches in the circuit other than the overcurrent device protecting the branch circuit.

(2) However, dwelling units in existing buildings may, in the alternative, be equipped with battery-operated smoke detecting devices except where such buildings are substantially improved or altered on or after January 1, 1982.

(3) An existing building is one which is within either Occupancy Group J-1 or Occupancy Group J-2 for which plans have been approved by the Department prior to December 31, 1981.

(4) A building shall be deemed to have been substantially improved or altered if

(i) the cost of improvement or alteration exceeds the sum of \$150,000 or

(ii) 50 percent or more of the dwelling units or square feet of the structure are improved or altered and the cost of such improvement or alteration exceeds the sum of \$15,000 per dwelling unit or

(iii) there has been a change in the occupancy or use of the entire structure.

(5) In applying the foregoing provisions where cost is the factor, items falling within the scope of minor alterations or ordinary repairs, as set forth in §§27-124 and 27-125 of the Administrative Code, thereby exempt from permit requirements based on §27-147, as well as any other cost associated with any matters that are not regulated by the Building Code are not included within calculation of the cost, as well as minor applications filed pursuant to Directive 14/75, or for any other miscellaneous applications referred to in §§27-148 (c) to (h).

(6) Cost of alterations are not cumulative, provided any application filed with this department is signed off as satisfactorily completed prior to the filing of a subsequent application; and, if a Certificate of Occupancy is involved that a final Certificate of Occupancy has been issued for the pertinent application.

(c) *Equipment requirements.*

(1) Section 27-981 of the Administrative Code provides that

all smoke detecting devices required to be provided and installed shall either be approved by the Board of Standards and Appeals, accepted pursuant to Rules and Regulations promulgated by the Commissioner, or be listed by a Nationally Recognized Independent Laboratory that:

(i) Maintains periodic inspections of production of listed equipment.

(ii) States in its listing that the equipment meets nationally recognized standards.

(iii) Maintains a periodic follow-up service of the devices to ensure compliance with the original listing.

(2) The following is the current list of Acceptable Testing Laboratories:

Underwriters' Laboratories, Inc.

333 Pfingsten Road Tele: (312) 272-8800

Northbrook, Illinois 60061 MEA Laboratory No. 1-69-L

Canadian Standards Association

178 Rexdale Boulevard Tele: (416) 744-4316

Rexdale, Ontario M9W 1R3 Canada MEA Laboratory

No. 25-69-L

Underwriters' Laboratories of Canada

7 Crouse Road Tele: (416) 757-3611

Scarborough, Ontario M1P 3A9 Canada MEA

Laboratory No. 81-80-L

(The Director of the Materials and Equipment Acceptance Division, who maintains the current list of MEA Acceptable Testing Laboratories, will be able to advise interested parties of any changes.)

(3) (i) The device shall be of either the ionization chamber or photoelectric type. The device shall be in compliance with the requirements of:

REFERENCE [sic] STANDARD RS 17-11

UL No. 217-1980—Single and Multiple Station Smoke Detectors. The device shall be installed in a manner consistent with the requirements of:

REFERENCE STANDARD RS 17-12

ANSI/NFPA No. 74-1980—Standard for the Installation, Maintenance and Use of Household Fire Warning Equipment, as Modified.

The following sections of this standard are modified to read as follows:

1-1 Scope. Covers the requirements for the proper selection, installation, operation and maintenance of fire warning equipment for use within dwelling units or rooming units.

1-2.6 The installation of wiring and equipment shall be in accordance with the New York City Electrical Code.

2-1.1.1 Smoke detectors shall be installed outside of each separate sleeping area in the immediate vicinity of the rooms used for sleeping purposes in dwelling units in Occupancy Group J-2 and J-3, and in basements and basement recreation rooms in Occupancy Group J-3.

Smoke detectors shall be installed within the sleeping area of hotel or motel units, rooming units or studio dwelling units in Occupancy Group J-1.

4-5.5 Each smoke detector shall have an integral test means to permit the occupant to check that it is operational. A continuous power display indicator light is recommended.

5-2.1.4 A smoke detector installed to protect a sleeping area

Rules and Regulations

in accordance with 2-1.1.1 shall be located outside the rooms used for sleeping purposes, but in the immediate vicinity of the sleeping area, except as set forth for rooming units.

5-2.1.6 Smoke detectors shall be located on or near the ceiling and within fifteen feet of all rooms used for sleeping purposes in J-2 or J-3 occupancies. In all dwelling units with multiple levels, when any level has only one means of egress, the dwelling unit shall be provided with smoke detectors on all levels.

5-2.6.1 If ceiling mounted, the closest edge of the detector shall be a minimum of four inches from any wall.

5-2.1.6.2 If wall mounted, the closest edge of the detector shall be a minimum of four inches and a maximum of twelve inches from the ceiling.

(ii) The following sections of this standard are extracted for informational purposes:

3-3.1 Household fire warning equipment may be powered by a battery provided that the battery is monitored to assure that the following conditions are met:

(a) All power requirements are met for at least one year's life, including weekly testing.

(b) A distinctive audible trouble signal is given before the battery is incapable of operating (from aging, terminal corrosion, etc.) the device(s) for alarm purposes.

5-1.1.6 The supplier or installing contractor shall provide the owner with:

(a) An instruction booklet illustrating typical installation layouts.

(b) Instruction charts describing the operation, method and frequency of testing and proper maintenance of household fire warning equipment.

(c) Printed information for establishing a household emergency evacuation plan.

(d) Printed information to inform the owner where he may obtain, [*sic*] repair or replacement service and where and how parts requiring regular replacement (such as batteries or bulbs)

may be obtained within two weeks.

NOTE: Owners of buildings in Occupancy Group J-2 are required to pass on all printed information as described in (b), (c) and (d) to the tenant who is responsible for maintaining the unit.

B-2.1 Where to locate the required smoke detectors.

B-2.1.1 The major threat from fire in a family living unit is at night when everyone is asleep. The principal threat to persons in sleeping areas comes from fires in the remainder of the unit; therefore, smoke detector(s) are best located between the bedroom areas and the rest of the unit. In units with only one bedroom area on one floor, the smoke detector should be located as shown in Figure B-2.1.1.

Figure B-2.1.1 A smoke detector (indicated by cross) should be located between the sleeping area and the rest of the family living unit.

B-2.1.2 In family living units with more than one bedroom area or with bedrooms on more than one floor, more than one smoke detector may be needed as shown in Figure B-2.1.2.

Figure B-2.1.2 In family living units with more than one sleeping area, a smoke detector (indicated by cross) should be provided to protect each, if the distant requirement of 5-2.1.6 is exceeded.

(4) (i) Buildings with Occupancy Group J-1 and including Class "B" Multiple [*sic*] Dwellings, may in the alternative be equipped with a line-operated zoned smoke detecting system with central annunciation and central office tie-in for all public corridors and public spaces.

(ii) Such system shall be in compliance with the requirements of the Division of Fire Prevention of the Fire Department and the following standards:

REFERENCE STANDARD RS 17-3

§13.—Automatic Heat and Smoke Detection System of the standards for the Installation of Fire Sprinkler, Standpipe Smoke Detection, Oxygen, Nitrous Oxide, and other Alarm and Extinguishing Systems.

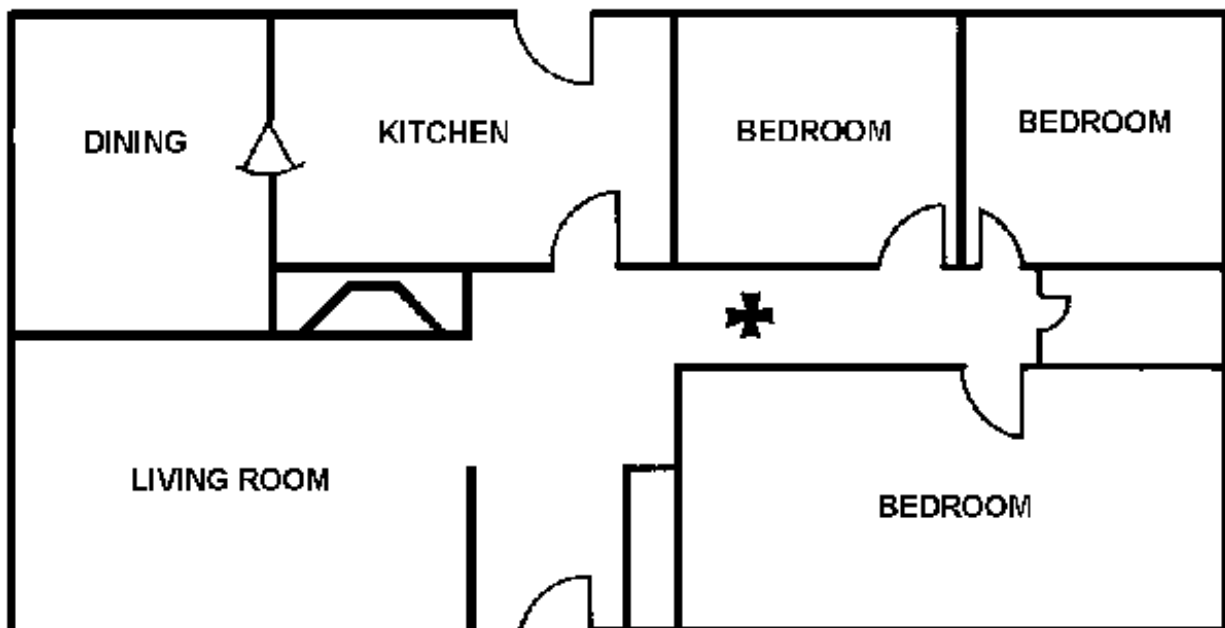

Rules and Regulations

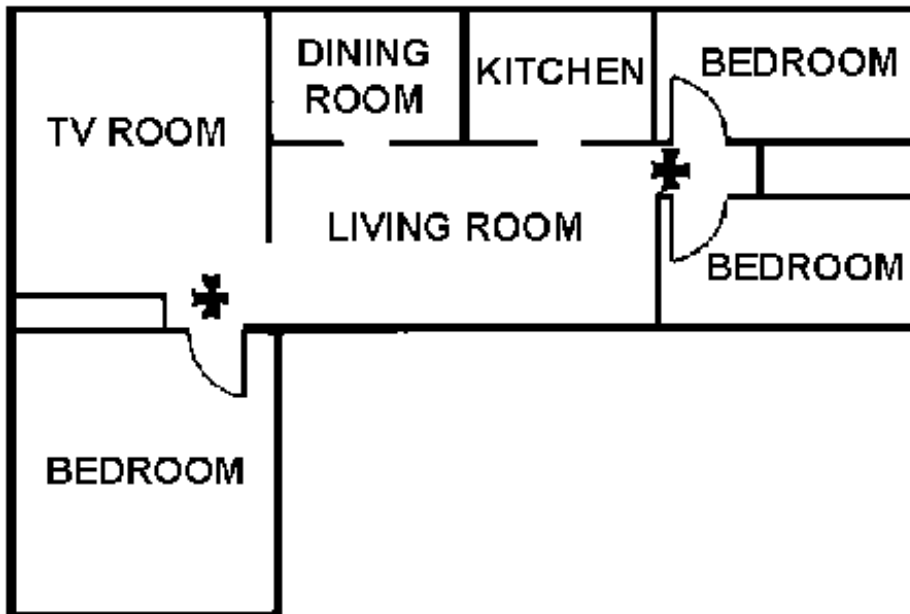

REFERENCE STANDARD RS 17-5A

ANSI/NFPA No. 72A-1979—Standard for the Installation, Maintenance and Use of Local Protective Signaling Systems for Guard's Tour, Fire Alarm and Supervisory Service.

REFERENCE STANDARD RS 17-5E

ANSI/NFPA No. 72E-1979—Standard of Automatic Fire Detectors.

(iii) All devices and equipment shall be approved by the Board of Standards and Appeals.

(5) (i) For dwelling units to be equipped with smoke detecting devices receiving their primary power from the building wiring, a Licensed Electrician shall file an application for a Certificate of Electrical Inspection with the Bureau of Electrical Control, Department of Buildings at the address provided in the City's website, <http://www.nyc.gov>.

(ii) For buildings within Occupancy Group J-1 (Class "B" Multiple Dwellings) using the alternate provisions of Paragraph D of these Rules, the following shall apply:

(A) A Miscellaneous Application shall be filed in the Borough Office of the Department of Buildings, by a Registered Architect or Professional Engineer. All fees are to be paid.

(B) A duplicate set of plans and specifications are to be forwarded for examination, approval and inspection to the Electrical Section, Division of Fire Prevention, Fire Department, prior to the signing-off of the application.

(C) Notice of approvals shall be forwarded to the Commissioner of the Department of Housing and Preservation.

(6) No applications are required to be filed for installation of battery operated devices.

(7) It shall be the duty of the owner of a building in Occupancy Group J-2 (Class "A" Multiple Dwelling) to:

(i) Provide and install one or more approved and operational smoke detecting devices in each dwelling unit.

(ii) Post a notice in a form approved by the Commissioner of the Department of Housing Preservation and Development in a common area of the building, readily visible and preferably in the area of the inspection certificate, informing the occupants of such building, that the owner is required by law to install one or more approved and operational smoke detecting devices in each dwelling unit in the building, and that each occupant is responsible for the maintenance and repair of such devices and for replacing any or all such devices which are stolen,

removed, missing or rendered inoperable during the occupancy of such dwelling unit.

(iii) Replace any smoke detecting device which has been stolen, removed, missing or rendered inoperable during a prior occupancy of the dwelling unit and which has not been replaced by the prior occupant prior to the commencement of a new occupancy of a dwelling unit.

(iv) Replace within thirty calendar days after the receipt of written notice any such device which becomes inoperable within one year of the installation of such device due to a defect in the manufacture of such device and through no fault of the occupant of the dwelling unit.

(v) File a certification of satisfactory installation within 10 days after completion with the Department of Housing Preservation and Development, Borough Division of Code Enforcement. This certification shall be set forth on a form available at the H.P.D. Borough Office.

(vi) Keep such records as the Commissioner of the Department of Housing Preservation and Development shall prescribe relating to the installation and maintenance of smoke detecting devices in the building and make such records available to the Commissioner of the Department of Housing Preservation and Development and/or the Fire Commissioner (or their representatives) upon request.

(8) It shall be the sole duty of the Occupant of each dwelling unit in a building in Occupancy Group J-2 (Class "A" Multiple Dwelling) in which a smoke detecting device has been provided and installed by the owner to:

(i) Keep and maintain such device in good repair; and,

(ii) Replace any and all devices which are either stolen, removed, missing or rendered inoperable during the occupancy of such dwelling unit.

NOTE: The occupant of a dwelling unit in which a battery operated smoke detecting device is provided and installed pursuant to this section shall reimburse the owner a maximum of ten dollars for the cost of providing and installing each such device. The occupant shall have one year from the date of installation to make such reimbursement.

(9) It shall be the duty of the owner of a building in Occupancy Group J-1 (Class "B" Multiple Dwelling) which is required to be equipped with smoke detecting devices to install and maintain such devices, and to keep such records as the Commissioner of the Department of Housing Preservation and Development

Rules and Regulations

shall prescribe relating to the installation and maintenance of smoke detecting devices in each dwelling unit and make such record available to the Commissioner of the Department of Housing Preservation & Development and/or the Fire Commissioner, (or their representatives) upon request.

(10) In Occupancy Group J-1 all components of the line operated zoned detecting systems, with central annunciators and central office tie-ins shall be inspected and tested by qualified personnel holding a Fire Department Certificate of Fitness for testing and maintaining smoke detecting systems at intervals of not more than six months. In addition, trouble signals shall be tested daily and each sounding device monthly and records of such test be maintained.

For further information, refer to the Board of Standards and Appeals, Rules for Interior Fire Alarm Signal Systems, §8-01 of the B.S.A. rules.

(11) Smoke detecting devices and systems installed in accordance with the technical requirements of Divisions C, D and E after publication of this Notice of Opportunity to Comment, may at the option of the owner continue to be operated after the effective date of the promulgation, and modification of such devices and systems will not be required.

§ 28-02 Required Carbon Monoxide Detecting Devices and Systems.

(a) Definitions.

(1) The term "CO" means carbon monoxide.

(2) The term "CO alarm" means a "carbon monoxide alarm" as defined in RS 17-14, and shall also mean a "carbon monoxide detecting device" as such term is used in the Subchapter 17 of Chapter 1, and Subchapter 2 of Chapter 2, of Title 27 of the Administrative Code of the City of New York. Such CO alarms may be combined with smoke detecting devices provided that the combined unit complies with the respective provisions of the administrative code, reference standards and departmental rules relating to both smoke detecting devices and CO alarms.

(3) The term "dwelling unit" means one or more rooms in a dwelling or building that are arranged, designed, used or intended for use by one or more families, including such units in occupancy groups J-1 (hotels, motels, lodging houses, rooming houses, etc.), J-2 (apartment houses, apartment hotels, school dormitory buildings, etc.), and J-3 (one- and two-family dwellings, rectories, convents, group homes, etc.).

(4) The term "fossil fuel" means coal, kerosene, oil, wood, fuel gases and other petroleum products.

(5) The term "fuel gases" shall include, but not be limited to, methane, natural gas, liquified natural gas and manufactured fuel gases.

(6) The term "fossil fuel burning equipment" shall mean any furnace, boiler, water heater, fireplace, apparatus, appliance or device that burns fossil fuel, excluding household cooking appliances and household (Type 1) gas clothes dryers.

(b) Location of CO alarms.

(1) In buildings containing dwelling units, including dwelling units classified in occupancy group J-1 (hotels, motels, lodging houses, rooming houses), J-2 (apartment houses, apartment hotels, school dormitory buildings) and J-3 (one- and two-family dwellings, rectories, convents, group homes), CO alarms shall be located as follows:

A. CO alarms shall be installed for the following

affected dwelling units:

i. Every dwelling unit located within a building that contains any fossil fuel burning furnace, boiler, or water heater as part of a central system;

ii. Every dwelling unit located within a building served by a central fossil fuel burning furnace, boiler or water heater that is located in an adjoining or attached building.

iii. If not already provided for by (i) or (ii) above, every dwelling unit on the same floor as, the floor below, and the floor above any other fossil fuel burning equipment that is located within the same building; and

iv. If not already provided for by (i) or (ii) above, every dwelling unit on the same floor as, the floor below, and the floor above any enclosed parking that is located in the same building.

B. When a CO alarm is required by 28-02(b)(1)(A), such CO alarms shall be installed within fifteen feet of the primary entrance to any room used for sleeping purposes. Where the dwelling unit comprises only one room (as in hotels), the CO alarm shall be installed within such room.

C. In J-1 occupancies, the owner may in the alternative elect to install a line-operated zoned CO detecting system with central annunciation and central office tie-in. Such system shall provide a CO alarm:

i. in all public corridors and public spaces at intervals specified by the manufacturer;

ii. in every room or space that contains a fossil fuel burning furnace, boiler or water heater;

iii. in every room or space adjacent to and on the same floor as the fossil fuel burning furnace, boiler or water heater;

iv. in every dwelling unit on the same floor as, on the floor below, and the floor above a room that contains a fossil fuel burning furnace, boiler or water heater;

v. in every dwelling unit connected by ductwork or ventilation shafts to a room that contains a the fossil fuel burning furnace, boiler or water heater; and

vi. in every dwelling unit on the same floor as, the floor below, and the floor above any enclosed parking that is located in the same building.

(2) In buildings classified in occupancy groups G and H-2, CO alarms shall be located as follows:

A. Occupied rooms and spaces. CO alarms shall be installed within such rooms or spaces where such rooms or spaces contain any fossil fuel burning equipment.

B. Sleeping rooms. CO alarms shall be installed within fifteen feet of the primary entrance to any room or space used for sleeping purposes in H-2 occupancies such as nursing homes, orphanages, and similar occupancies (except patient rooms in hospitals) located within a building containing any fossil fuel burning furnace, boiler, or water heater as part of a central system. Such CO alarms may be located in public corridors, provided that at least one CO alarm is located within 15 feet of the primary entrance to each sleeping room.

C. Non-occupied rooms and spaces. Supervised CO alarms shall be installed within such rooms or spaces where such rooms or spaces contain any fossil fuel burning equipment. However, in existing buildings classified in occupancy groups G and H-2 that are not substantially altered or improved as per § 28-02(d)(2)(A) of this rule, any required CO alarms may, at the option of the owner, be single-station CO alarms in compliance with the installation requirements of § 28-02(d)(2).

Rules and Regulations

(c) Equipment Requirements.

(1) All CO alarms for occupancy groups J-1, J-2, J-3, G, and H-2 shall be in compliance with RS 17-13, however, for G and H-2 occupancies, the design professional may utilize CO alarms responding to a lower level of CO concentration (PPM) than the reference standard, subject to approval of the department and of the Fire Department of New York.

(2) For J-1 occupancies, all line-operated zoned CO detecting systems with central annunciation and central office tie-in shall also comply with the following:

A. The individual alarm that detects CO shall sound locally, and may, at the option of the owner, also sound other alarms on that zone or elsewhere in the building.

B. Each CO alarm shall report to a central station monitoring company approved by the Fire Department of New York as an "alarm signal" and shall be identified to the monitoring company as CO. CO alarm troubles shall be reported to the central station as a "trouble signal."

C. Such system shall be either:

i. powered and supervised by a fire alarm system, installed in accordance with RS 17-3, 3A, or 3B, and connected to a central station transmitter; such system shall comply with RS 17-14 §§ 5.3.7 and 5.3.9; or

ii. powered and supervised by a dedicated CO alarm system, installed in accordance with RS 17-3 and connected to a central station transmitter; such system shall comply with RS 17-14 § 5.3.9.

D. The CO alarms, control panels and central station transmitters of such systems must be approved by the Material Equipment Acceptance Division (MEA).

(3) For G and H-2 occupancies, except for existing buildings not substantially altered or improved as per § 28-02(d)(2)(A), supervised CO alarms for non-occupied rooms and spaces shall also comply with the following:

A. Each CO alarm shall sound locally within the non-occupied room or space;

B. Except where the CO alarm signal does not report to a central station monitoring company as provided for in ii. below, each CO alarm shall report to a central station approved by the Fire Department of New York as an "alarm signal" and shall be identified to the monitoring company as CO. CO alarm troubles shall be reported to the central station as a "trouble signal." Such system shall be either:

i. powered and supervised by a fire alarm system, installed in accordance with RS 17-3, 3A, or 3B, and in accordance with RS 17-14 § 5.3.7; or

ii. powered and supervised by a dedicated CO alarm system, installed in accordance with RS 17-3; however, such system is not required to transmit to a central station monitoring company provided that the system is continually monitored by full time on-site staff during periods that the building is occupied.

C. Such systems' CO alarms, and control panels must be approved by the Material Equipment Acceptance Division (MEA).

(d) Installation.

(1) Power source. All CO alarms shall be hard-wired, receiving their primary power from the building wiring, in compliance with RS 17-14 § 5.2.2, with secondary battery back-up in compliance with RS 17-14 § 5.2.4. Where more than one hard-wired CO alarm is required within the same dwelling unit, all such alarms shall be

interconnected.

(2) Existing buildings. Buildings in existence on November 1, 2004, and buildings with work permits issued prior to November 1, 2004, may, in the alternative, be equipped with battery-operated CO alarms compliant with RS 17-14 § 5.2.3 or plug-in type CO alarms with a back-up battery compliant with RS 17-14 § 5.2.4, except where such buildings are substantially improved or altered on or after November 1, 2004.

A. A building shall be deemed to have been substantially improved or altered if:

i. 50 percent or more of the dwelling units in occupancy group J-1, J-2, or J-3 are improved or altered and the cost of such improvement or alteration exceeds the sum of \$25,000 per dwelling unit;

ii. 50 percent or more of the square footage of the structure is improved or altered for J-1, J-2, J-3, G, or H-2 occupancies and the cost of the improvement or alteration exceeds \$500,000; or

iii. there has been a change in the occupancy or use of the entire structure to J-1, J-2, J-3, G, or H-2 occupancies.

B. In applying the foregoing provisions where cost is the factor, items falling within the scope of minor alterations or ordinary repairs, as set forth in §§27-124 and 27-125 of the Administrative Code, thereby exempt from permit requirements based on §27-147, as well as any other cost associated with any matters that are not regulated by the Building Code, are not included within calculation of the cost.

C. Costs of alterations are not cumulative, provided any application filed with this department is signed off as satisfactorily completed prior to the filing of a subsequent application; and, if a Certificate of Occupancy is involved, that a final Certificate of Occupancy has been issued for the pertinent application.

D. Time for compliance. The CO alarms shall be operational in existing buildings in occupancy groups J-1, J-2, J-3, G, and H-2 by November 1, 2004; however, the commissioner may upon good cause shown extend the period of compliance to June 30, 2005.

E. Where a dwelling has existing hard-wired smoke detecting devices installed pursuant to 1 R.C.N.Y. § 28-01(b)(1), combination smoke detecting device/CO alarms are not permitted unless the combination units are hard wired.

F. Extension of time for compliance.

i. Appeals to the commissioner for extension of the period of compliance shall be set forth on a form filed at the applicable borough office of the Department of Buildings, no later than December 1, 2004, and contain the following information:

aa. Location of premises, block and lot, Building Department Application number, if any, Occupancy Classification, number of dwelling units, estimated number of CO alarms, type, and where they are to be installed.

bb. The hardship to be considered with regard to the delivery or installation of the equipment.

cc. The proposed time table for compliance.

dd. A copy of the signed contract for the purchase and/or installation of the system. (Cost figures may be deleted).

ii. The Commissioner will not consider "good cause" appeals unless all required annual boiler inspections for the building are filed and up to date and no open boiler violations exist and:

Rules and Regulations

aa. The installation of the CO alarms is hard-wired into the building's electrical system in accordance with RS 17-14 § 5.2.2.; or

bb. The number of units in single ownership or management responsibility exceed 500, and a complete schedule for installation is submitted prior to December 1, 2004; or

cc. Special circumstances not covered by subdivisions (i) or (ii) above are involved.

iii. Notice of approved extensions for J-1, J-2, and J-3 occupancies are to be forwarded to the Commissioner of the Department of Housing Preservation and Development.

(3) Reference Standard. CO alarms for J-1, J-2, J-3, G, and H-2 occupancies shall be installed in accordance with RS 17-14.

(e) Filing requirements.

(1) Applications for the installation of any CO alarm system in J-1, G, or H-2 occupancies that connects to a fire alarm system or reports to a central station monitoring company shall be filed with the Department of Buildings and Fire Department of New York following the same administrative procedures as filing of fire alarm applications.

(2) Applications for the installation of any CO alarm system in G or H-2 occupancies that is required to be continually monitored may be filed under Directive 14 of 1975 provided:

i. the system is not connected to a fire alarm system; or

ii. the system does not report to a central station monitoring company.

(3) Applications for the installation of other hard-wired CO alarms shall be filed with the Bureau of Electrical Control where filing is required by the New York City Electrical Code.

(4) For existing buildings that are not substantially improved or altered, installation of single station CO alarms that receive primary power from batteries or that are plug-in type with back-up batteries does not require filing with the Department of Buildings.

CHAPTER 29 SPRINKLER SYSTEMS

§29-01 Installation of Automatic Sprinklers in Halls and Rooms in Class "A" Multiple Dwellings Used For Single-Room Occupancy Under the Provisions of Subdivision 7-A of §4 and §248 of the Multiple Dwelling Law.

(a) Before the installation of any sprinkler system in any single-room occupancy building is begun, an application, together with plans and specifications for such installation shall be filed with and approved by the Department of Buildings. Plans shall show accurately, both horizontally and vertically, the arrangement and dimensions of the private halls and rooms and the areas to be sprayed by each sprinkler head.

Application and specification forms may be obtained at the borough office of the Department of Buildings. Applications shall be filed in the department office in the borough in which the premises are located. Applications and specifications shall be in triplicate. Preliminary plans may be on paper. Final plans shall be filed in triplicate on paper and microfilmed.

When it is proposed to supply a sprinkler system by means of a direct connection to a public water supply main, the specifications shall be accompanied by a letter from the Department of Environmental Protection, establishing the fact that the water-supply conditions and pressures are suitable to meet the

requirements of these rules for water supplies for sprinklers.

(b) Sprinkler systems shall be of the automatic wet type.

(c) Water supply from public water mains will be acceptable when such supply will provide a minimum static pressure at the highest sprinkler head or heads of not less than 15 pounds per square inch.

Taps connecting to public water mains must be equal in size to the main pipe line, except that:

A two-inch (2") tap connecting to the public water main and immediately increased to two-and-one-half inches (2 1/2") direct connection to the public water main and,

A one-and-one-half inch (1 1/2") tap connecting to the public water main and immediately increased to two inches (2") in diameter, with piping of the same diameter extending into the building, shall be considered the same as a two-inch (2") direct connection to the public water main.

The sprinkler system of each building shall have a separate and independent source of supply. When a sprinkler system is supplied direct from a public water main, it shall be separately and independently connected to the public water main. However, a house service water supply connection may be taken from the sprinkler water supply connection to the public main, on the house side of the main shut-off valve for the building, provided the diameter of the house service water supply connection does not exceed one-half of the diameter of the sprinkler water supply connection. Only one connection of the domestic water supply to the sprinkler water supply line shall be permitted and no shut-off valve shall be placed on the sprinkler supply line other than the main shut-off valve for the building on the street side of the house service water supply connection.

(d) A gravity tank upon the roof will be required when the normal minimum water pressure from the public mains is insufficient, or, in lieu of a gravity tank, a pressure tank may be installed in the basement or cellar in accordance with the requirements hereafter specified in these rules.

The bottom of each gravity tank supplying the sprinkler system shall be elevated at least 20' above the roof.

Each gravity tank shall be filled through a fixed water supply tank of at least one-and-one-half inch (1 1/2") diameter and independent of the sprinkler pipe system, by means of an automatically controlled pump of a discharge capacity of at least sixty-five (65) gallons per minute against the total head, including friction at the discharge nozzle of the pump. The tank fill line shall be standard weight pipe, galvanized steel, or brass or copper pipe.

A gravity tank, if used exclusively to supply the sprinkler system, shall have an effective capacity of not less than 1,500 gallons. Gravity tanks which serve both the house supply and the sprinkler system shall have a capacity of not less than 2,500 gallons.

All exposed water supply piping connecting with roof gravity tanks shall be properly protected against frost action by four layers of one inch (1") high-grade hair felt, and each layer of hair felt shall be covered with a layer of heavy tar paper.

Each wrapping must be securely fastened with heavy twine, and wrapping joints shall have a lap not less than two inches (2"), staggered with the laps of adjacent layers.

All coverings shall be finally covered with heavy canvas, painted with two coats of waterproof [*sic*] paint.

In lieu of the foregoing, three inch thick fiberglass in a metal shield may be used.

(e) Pressure tanks when used shall be capable of supplying actual water volume as required in subdivision (j) of this section of these rules. The required water volume shall be two-thirds of the tank capacity and the [*sic*] air pressure one-third.

Rules and Regulations

For the pressure to be maintained, pressure tanks shall be constructed and tested in accordance with the requirements of the ANSI/NFPA 22 of Reference Standard RS 17-10 of the Administrative (Building) Code.

At the end of each pressure tank there shall be a glass water level gauge, and the pressure tank must also be provided with a pressure gauge and manhole for access to the tank.

The filling pump for the pressure tank shall have a capacity of 65 gallons per minute with sufficient strength to pump water into the pressure tank against full air pressure.

The air compressor for the pressure tank must be capable of delivering ten cubic feet of air per minute for the permanent maintenance of the required maximum air pressure in the tank.

The filling pipe from pump to air compressor must be provided with a relief valve set at 15 pounds in excess of the maximum air pressure carried in the tank.

(f) All tanks shall be supported in accordance with the provisions of the Administrative (Building) Code.

All tanks shall be provided with emergency outlets in conformity with Section P107.8(c) of Reference Standard RS-16 of the Administrative (Building) Code.

(g) Standard one-half inch (1/2") spray type sprinkler heads. Each private hall and room within an apartment having single-room occupancy shall be sprinkled as hereinafter provided. In private halls within apartments, sprinkler heads shall be placed not more than fourteen feet (14') apart. No sprinkler head in a hallway shall be distant more than seven feet (7') from a wall, partition or end of the hall.

No sprinkler protection will be required within any closet with a floor area of not more than 20 square feet provided such closet is within a room and the area of the closet is considered as part of the room area in computing the required number of heads.

(h) The term "protected area" shall be construed to mean that single-room occupancy apartment within the building requiring the greatest number of sprinkler heads. In computing the required number of heads within a "protected area," the number of heads within the same apartment may be used on the condition that there is no connection to another apartment or private hall.

Whenever there is a direct connection between two adjoining apartments, either or both of which are used for single-room occupancy, the combined connected apartments and private halls shall be considered as the "protected area." In computing the required number of heads in a "protected area" of this type, the number of heads within the rooms in the connected apartments or the number of heads required in the private halls of such connected apartments, whichever is greater, shall be used.

(i) The total number of heads in the "protected area" requiring the greatest number of heads shall determine the required size of the main supply, including service mains, main branch, tank, down feed and riser, but in no case shall the size of the main supply be less than two inches.

(j) There shall be sufficient actual water volume to supply 25 percent of the heads in the "protected area" requiring the greatest number of heads for a period of 20 minutes at 20 gallons per minute.

(k) The number of sprinkler heads on a given size of piping shall not exceed the following:

| Size of pipe diameters | Maximum number of sprinkler heads allowed |
|------------------------|---|
| 1 inch..... | 2 heads |
| 1 1/4 inch..... | 3 heads |
| 1 1/2 inch..... | 5 heads |
| 2 inch..... | 10 heads |
| 2 1/2 inch..... | 30 heads |
| 3 inch..... | 60 heads |
| 3 1/2 inch..... | 100 heads |
| 4 inch..... | Unlimited heads |

(l) The sprinkler main shall not be less in size than the sprinkler riser and [sic] the check valve of equal diameter to the main and the riser shall be provided on the sprinkler main. For draining the sprinkler system, a 3/4" plugged valve shall be provided on the sprinkler main just inside the aforesaid check valve. All sprinkler piping and fittings shall be so installed that they can be thoroughly drained.

On the sprinkler main, an outside screw and yoke gate valve, readily accessible, must be provided near the front of the front of the building and located so as to control the water supply to all of the interior sprinkler systems. The said outside screw and yoke gate valve must be sealed in an open position.

If tank water supply is used for sprinklers, an outside screw and yoke gate valve shall be provided on the piping leading from the tank to the sprinkler system under conditions similar to those specified for such valves on sprinkler mains.

(m) Sprinkler risers shall not be located close to windows and all sprinkler piping shall be properly supported.

(n) Sprinkler systems shall be maintained for sprinkler use only, and connections to such sprinkler systems for any other purposes are prohibited.

(o) All piping used in sprinkler systems shall be full weight standard steel threaded pipe, well reamed and screwed up tight into fittings without reducing the waterway. Fittings shall be standard cast iron. All fittings placed inside of tank shall be of brass or other non-corroding material.

(p) Sprinkler risers shall be provided at the top for testing purposes, with a connection not less than one inch in diameter, with a valved outlet so located that same will be readily accessible at all times. When not in use, the valve shall be provided with an iron or brass plug screwed in tight.

(q) Sprinkler systems when completed shall be subjected to a hydrostatic test at a pressure of not less than thirty pounds in excess of the normal pressure required for such sprinkler systems when in service, and shall remain uncovered in every part until they have successfully passed the test. The Department of Buildings, in the borough in which the test is to be conducted, shall be notified when such test is to take place. Tests shall be conducted by the contractor or the owner or [sic] the owner's representative, in the presence of a representative of the Building Department.

(r) Sprinkler systems shall be inspected at least once in each month by a competent representative of the owner, to ascertain that all parts of the system are in perfect working order. A detailed record of each inspection shall be kept on the premises for examination by the Fire Department, the Department of Housing Preservation and Development, and the Department of

Rules and Regulations

Buildings.

(s) There shall be kept available on the premises at all times a sufficient supply of extra sprinkler heads and also a sprinkler wrench for use to replace promptly any fused or damaged sprinkler heads.

Any head which has opened or has been damaged shall be replaced immediately with a good sprinkler head.

Sprinkler heads shall be of a type and manufacture approved by the Board of Standards and Appeals.

The minimum operating temperature of all sprinkler heads shall be in the ordinary degree range. Appropriate higher degree operating temperatures shall be required in cooking spaces.

§29-02 Installation of Automatic Wet-Pipe Sprinklers in Certain Class A and Class B Multiple Dwellings, Including Hotels, Under the Provisions of §67, Multiple Dwelling Law.

Effective February 25, 1949, automatic wet-pipe sprinklers used in certain Class A and Class B multiple dwellings, including hotels, shall be installed in conformity with the provisions of the Administrative Code, Subchapter 17 of Chapter 1 of Title 27, except as modified herein.

These rules do not apply to sprinkler installations in converted dwellings, lodging houses or multiple dwellings used for single room occupancy.

(a) In lieu of one of the four alternate automatic sources of water supply specified in §27-961, of the Administrative (Building) Code, a connection may be made to the domestic water supply system on the condition that:

(1) It can be established from information obtainable from the Department of Environmental Protection that the pressure at the top of the highest riser will be 15 pounds per square inch (except as provided in §29-02(f)).

(2) If the pressure from this source is insufficient to provide a pressure of 15 pounds at the highest line of sprinklers, but is sufficient to supply a pressure of 15 pounds or more at the highest line of sprinklers, an automatic booster pump is provided, the capacity of which shall be sufficient to supply 25 percent of the standard one-half inch (1/2") inch heads in the sprinkler area having the maximum number of heads, and in no event shall such supply be less than 250 gallons per minute at a pressure of at least 15 pounds at the highest sprinkler line.

(3) A local approved type of water-flow alarm is provided, the gong so located that when it operates it may be heard by the occupants or employees, and the gong also plainly marked "Sprinkler Alarm", in red letters one inch in height on a white background.

Exception: In a sprinkler area which does not contain more than 36 heads, no water-flow alarm shall be required.

(4) A sprinkler shut-off valve is provided conveniently accessible and its purpose clearly indicated by the words "Automatic Sprinkler Shut-Off Valve" on a sign affixed thereto.

(5) The size of the domestic water supply line is at least equal to the size of the main sprinkler connection. *Note:* The provisions of Paragraph c of §27-964 shall not apply to sprinklers installed in conformity with the provisions of §29-02(a).

(b) The capacity of gravity tanks for sprinklers shall be in conformity with the provisions, of §27-965, or such tank may be supplied by an automatic filling pump of at least 65 gallons per minute capacity, which shall be sufficient to supply 25 percent of the sprinkler heads in the largest sprinkler area for 20 minutes. The capacity of such tank shall be not less than

1,000 gallons. The bottom of the gravity tank or sprinkler supply pipe shall be not less than 20 feet above the highest supplied sprinkler line. When such elevation is not practicable, an automatic booster pump may be installed in the main sprinkler supply line in conformity with §29-02(a)(2).

(c) In lieu of complying with the provisions of §27-965, a pressure tank located not more than one story below the highest supplied sprinkler line, filled by an automatic pump, and with a supply of water, all as described in §29-02(b) may be installed. In addition, a high-and-low air-alarm shall be provided.

(d) The provisions of §27-963(a) may be construed to permit the sprinkler connection to the street main to be the same size as main sprinkler riser, but in no instance shall it be less than two inches. A tap may be one pipe size less than the sprinkler main.

(e) §27-935 shall apply only when the number of heads in any sprinkler area as defined in these rules exceeds 36.

(f) *Standard 1/2-inch sprinkler heads.* In lieu of applying the provisions of §27-956, sprinkler heads shall be so spaced that there shall be one head for approximately 168 square feet of floor area, and shall also be spaced not more than 14 feet on centers. The distance from a wall or partition to the first sprinkler head shall not exceed seven feet, measured at right angles to the wall or partition. In multiple dwellings that are presently equipped with sprinklers, the heads in the public halls may be spaced 14 feet on centers, with the first head not more than seven feet from any wall or partition. A 12 pound static pressure will be accepted at the topmost sprinkler line, provided the sprinkler heads are spaced to cover 100 square feet or less. Sprinkler heads may be installed in covered shafts in lieu of fire-retarding on the condition that:

(1) Such shafts are not exposed to freezing temperatures;

(2) If ventilating louvres, windows or skylights are present in such shafts, the highest head is located a sufficient distance from such openings to prevent freezing;

(3) One head is centered at the top of such shaft at the level of the highest ceiling;

(4) In shafts constructed of [*sic*] incombustible materials, excepting windows or doors opening thereon, sprinkler heads are placed at each floor level and are staggered at alternate levels;

(5) In shafts constructed of combustible materials, and which exceed 60 square feet in cross-sectional area, sprinkler heads are placed at each floor level and are staggered at alternate floor levels.

(g) The protection afforded by sprinklers to stairs, halls, corridors, and other passageways shall also apply to their soffits and overlaps.

(h) These rules shall also apply to a store or other space used for business on any story where there are no sleeping rooms and which is not provided with sprinkler heads, unless such spaces are otherwise arranged in conformity with the provisions of Section 6l, Multiple Dwelling Law.

(i) In lieu of complying with the provisions of §3-9.1.1 of ANS/NFiPA 13 of Reference Standard RS 17-2 of the Administrative (Building) Code, a 1 inch valved pipe may be extended from the top of the riser to the outside of the building, or inside the building to a deep sink for testing the system, pump and alarm under water-flow conditions.

(j) Check valves, gate valves, and water meters shall be installed

Rules and Regulations

as and when directed by the Department of Environmental Protection.

(k) The term "sprinkler area" as used in these rules shall mean any floor space within a structure enclosed on all sides by exterior walls, fire walls, fire partitions, fire-retarded partitions, or fire-resistive partitions and doors acceptable to the Department of Housing and Buildings. The term "fire-resistive partition" as used in these rules shall mean a partition which is constructed of incombustible materials or wood studs covered on both sides with lath and plaster, plaster board, or other fire-resistive materials acceptable to the Department.

Such partitions shall extend from the floor to the ceiling. All doors in such partitions shall be self closing.

(l) The sprinkler control valve shall be inspected at least once weekly by a competent person, who is employed by the owner to see that such valves are sealed open, and who holds a certificate of fitness. A record of each inspection shall be kept for examination by a representative of the Department. The provisions of §27-957, in relation to alarm devices shall not apply to a sprinkler area which does not contain more than 36 heads in multiple dwellings, in which such weekly inspections are made.

(m) Systems installed before July 1, 1928 shall be subject to inspection and if found adequate may be accepted by the Department of Buildings. However, in such cases, a copy of the plans approved by the Fire Department shall be filed with the Department of Buildings.

(n) Where there are practical difficulties in the way of carrying out these rules, the Superintendent may permit modifications, provided that the spirit of these rules are observed and safety secured.

§29-03 Installation of Automatic Wet-Pipe Sprinkler Systems and Alarm Systems in Certain Class B Multiple Dwellings (Lodging Houses).

(a) Notice is hereby given that, pursuant to the provisions of Chapter 713 of the Laws of 1929, and Section 4 of Chapter 553 of the Laws of 1944, effective April 5, 1944, automatic wet pipe sprinkler systems installed in "lodging houses", shall be installed in conformity with the provisions of the Administrative Code of the City of New York.

(b) An automatic closed-circuit water-flow and valve-tamper alarm system, having at least one manual fire alarm station shall be provided in connection with the sprinkler system. This alarm system shall be connected to an approved central station which provided supervisory and maintenance service satisfactory to the fire commissioner.

In connection therewith, there shall be an approved transmitter so arranged as to actuate all gongs of the interior fire alarm system whenever a water flow through the sprinkler system occurs.

Interior fire alarm systems of the closed-circuit type previously installed under the rules then in force and approved by the fire commissioner may be accepted if, after inspection and test the systems are found to be adequate and in proper operating condition.

Battery operated interior fire alarm systems of the open-circuit type shall be replaced with an approved closed-circuit system.

In connection with these rules, the persons affected are advised to consult Article 5 of Subchapter 17 of Chapter 1 of Title 27, of the Administrative (Building) Code and §§15-126, 15-127 and 15-214, of the Administrative (Fire Prevention) Code of the city

of New York, concerning interior fire alarm system, watchmen's time detector system and telegraphic communication.

§29-04 Installation of Automatic Wet-Pipe Sprinkler Systems and Alarm Systems in Certain Class B Multiple Dwelling (Lodging Houses).

(a) Automatic wet-pipe sprinkler systems installed in lodging houses in compliance with Subdivision 3, of §66, of the Multiple Dwelling Law shall be in conformity with the provisions of the Administrative Code, Subchapter 17 of Chapter 1 of Title 27, only to the extent that such article is not inconsistent with these amended rules.

(1) Sprinkler systems shall be automatic wet-pipe with one automatic source of water supply.

(2) Acceptable automatic sources of water supply shall be any one of the following:

(i) Elevated gravity tank having a minimum capacity of 5,000 gallons and installed in accordance with §27-965 of the Administrative (Building) Code. Effective capacity shall be determined by the largest number of heads in any floor area multiplied by 75 gallons, and shall never be less than 5,000 gallons.

(ii) Pressure tank having a minimum capacity of 2,500 gallons and installed in accordance with §27-965 of the Administrative (Building) Code. Effective water capacity shall be determined by the largest number of heads in any floor area multiplied by 37.5 gallons, and shall never be less than 2,500 gallons.

(iii) Automatic fire pump having a capacity of not less than 250 gallons per minute and installed in accordance with §27-964 of the Administrative (Building) Code.

(iv) A direct connection to the public water main, provided it is capable of maintaining a pressure of at least 15 pounds per square inch at the top of the highest sprinkler riser, with 250 gallons of water flowing per minute at a 2 1/2-inch outlet from a hydrant at the street level within 250 feet of the building. The hydrant test shall be made between the hours of 8 a.m. and 5 p.m. on a working day.

If the public water main pressure is incapable of maintaining a minimum pressure of 15 pounds per square inch as specified herein, a booster pump may be installed in conformity with these rules; or, in lieu of such booster pump, the sprinkler spacing and pipe sizes for the area not having the required minimum water pressure of 15 pounds per square inch shall be in conformity with the provisions of §27-956 of the Administrative (Building) Code, provided that in no event shall [*sic*] the minimum water pressure at the highest sprinkler riser be less than 2 pounds per square inch. Booster pumps, if required, shall have a capacity sufficient to supply 250 gallons per minute, at a pressure of at least 15 pounds at the top of the highest sprinkler riser. All shall be installed in accordance with §27-964 of the Administrative (Building) Code.

A letter from the Department of Environmental Protection shall be filed with the application for the installation of a sprinkler system, stating the water pressure and supply conditions of the street main to which the sprinkler supply is to be connected.

(3) One common source of water supply shall be acceptable for any contiguous buildings under the same ownership or leasehold and under the same lodging-house management, provided that each such building is fully separated by fire walls with automatic fire doors on any connecting openings.

Rules and Regulations

Supply mains shall be at least the size of the largest main riser in any one building and shall be arranged to be centrally located and run as directly as possible from the source of water supply to the respective risers in each building.

Each building shall be provided with a separate alarm valve in accordance with §29-04(a)(8).

In all other respects, the installation in each building shall comply with these rules.

Supply mains shall be increased in size as may be required for adequate water supply and pressure requirements in accordance with §29-04(a)(2).

(4) Sprinkler spacing for standard 1/2-inch heads under sheathed or plaster ceilings shall not exceed 168 square feet of protection area, with the distance between lines and between sprinklers on lines not in excess of 14 feet.

(5) The maximum permissible number of standard 1/2-inch sprinkler heads on a given pipe-size, in one fire area, on any one story shall be as follows:

| Size of pipe diameters | Maximum number of sprinkler heads allowed |
|------------------------|---|
| 1 inch | 2 heads |
| 1 ¼ inch | 3 heads |
| 1 ½ inch | 5 heads |
| 2 inches | 10 heads |
| 2 ½ | 30 heads |
| 3 inches | 60 heads |
| 3 ½ inches | 100 heads |
| 4 inches | Unlimited heads |

Branch lines should not exceed eight sprinkler heads on either side of a cross main.

Areas within fire walls may be subdivided into separate fire areas by one-hour partitions. Openings in such partitions shall be protected with fireproof doors and assemblies, and such doors shall be self-closing. Areas within such subdivisions may be considered independent fire areas.

(6) Each riser shall be of sufficient size to supply all the sprinkler heads on that riser in any one fire area according to §29-04(a)(5).

The supply main shall be at least the size of the riser it serves, except that no main shall be less than two inches and shall be installed in accordance with §27-956 of the Administrative (Building) Code.

(7) Taps in the public water main may be one standard pipe-size smaller than the required supply main according to §29-04(a)(6), provided the supply main immediately increases at the tap to its full required size.

All water main installations shall be subject to the approval of the Department of Environmental Protection.

(8) Systems shall be equipped with an alarm valve so constructed that any flow of water in any part of the system, or the closure of any valve controlling water supply will automatically cause the interior fire alarm system and the central station alarm to operate.

(9) Prior to the issuance of a letter of approval from the Department of Buildings as to the satisfactory installation of any system, a letter from the Department of Environmental Protection must be filed with the Department as to the size of tap and service main and its satisfactory installation.

(b) An automatic closed-circuit water-flow and valve-tamper alarm system, having at least one manual fire alarm station shall be provided in connection with the sprinkler system. This alarm system shall be connected to an approved central station which provided supervisory and maintenance service satisfactory to the fire commissioner.

In connection therewith, there shall be an approved transmitter so arranged as to actuate all gongs of the interior fire alarm system whenever a water flow through the sprinkler system occurs.

Interior fire alarm systems of the closed-circuit type previously installed under the rules then in force and approved by the fire commissioner may be accepted if, after inspection and test the systems are found to be adequate and in proper operating condition.

Battery operated interior fire alarm systems of the open-circuit type shall be replaced with an approved closed-circuit system.

In connection with these rules, the persons affected are advised to consult Article 5 of Subchapter 17 of Chapter 1 of Title 27, of the Administrative (Building) Code and §§15-126, 15-127 and 15-214, of the Administrative (Fire Prevention) Code of the city of New York, concerning interior fire alarm system, watchmen's time detector system and telegraphic communication.

§29-05 Installation of Automatic Wet-Pipe Sprinklers in Fireproof Multiple Dwellings Converted to Business Use.

(a) Except as otherwise provided herein, automatic wet-pipe sprinklers used in fireproof multiple dwellings, converted in whole or in part to business use under the provisions of §27-248 of the Administrative (Building) Code, in effect prior to December 6, 1968, and in fireproof multiple dwellings that are altered under the provisions of §9, Subdivision 5, Paragraph b, of the Multiple Dwelling Law (subdivision of large apartments) shall be installed in conformity with Subchapter 17 of Chapter 1 of Title 27 of the Administrative (Building) Code.

(b) In lieu of one of the four alternate automatic sources of water supply specified in §27-961 of the Administrative (Building) Code, a connection may be made to the domestic water supply system on the condition that:

(1) It can be established from information obtainable from the Department of Environmental Protection that the minimum static pressure at the top of the highest riser will be at least 15 pounds per square inch, except as otherwise provided in §29-05(g).

(2) If the pressure from this source is insufficient to provide a minimum static pressure of 15 pounds per square inch, at the highest line of sprinklers, but is sufficient to supply a pressure of 5 pounds per square inch or more at the highest line of sprinklers, and that an automatic booster pump is provided, the capacity of which shall be sufficient to supply 250 gallons per minute at a pressure of at least 15 pounds per square inch at the highest sprinkler line

(3) A sprinkler shut-off valve is provided conveniently accessible, and its purpose clearly indicated by the words "Automatic Sprinkler Shut-Off Valve" on a sign affixed thereto, and that such valve is sealed open.

(4) The size of the domestic water supply line is at least equal in size of the main sprinkler connection.

(5) The provisions of Paragraph c of §27-964 shall not apply to sprinklers installed in conformity with the provisions of this

Rules and Regulations

§29-05(b).

(6) Where the length of pipe from the furthest sprinkler to the riser exceeds 100 feet the pipe beyond the 100 foot distance shall be increased in size one pipe size above the size otherwise required for each 100 feet of additional length or part thereof. This provision shall not require an increase in the size of the risers.

(7) A separate riser shall be provided in each required stair enclosure, separately controlled.

(c) The capacity of gravity tanks for sprinklers shall be in conformity with the provisions of §27-965, or such tank may be supplied by an automatic filling pump capable of delivering at least 65 gallons per minute to the tank and shall have sufficient capacity to supply 25 percent of the sprinkler heads in the largest sprinkler area for 20 minutes, at 20 gallons per minute. The capacity of such tank shall not be less than 1,500 gallons. The bottom of the gravity tank, or the sprinkler supply pipe shall not be less than 20 feet above the highest supplied sprinkler line. When such elevation is not practicable, an automatic booster pump may be installed in the main sprinkler supply line in conformity with §29-05(b)(2).

(d) In lieu of complying with provisions of §27-965, a pressure tank located not more than one story below the highest supplied sprinkler line, filled by an automatic pump, and with a supply of water, all as described in §29-05(c), may be installed. In addition, a high-and-low air-alarm shall be provided.

(e) §27-963 may be construed to permit the sprinkler connection to the street main to be the same size as the main sprinkler riser, but in no instance shall it be less than 2 inches. A tap may be one pipe size less than the sprinkler main.

(f) §27-940 shall apply only when the number of sprinkler heads in any fire area as defined in these rules exceeds 36.

(g) In lieu of applying the provisions of §27-956, sprinkler heads shall be so spaced that there shall be one head for approximately 130 square feet of floor area, and heads shall be spaced not more than 14 feet on centers. The distance from a wall or partition to the first sprinkler head shall not exceed seven feet measured at right angles to the wall or partition. A 12 pound minimum static pressure will be accepted at the topmost sprinkler line, provided the sprinkler heads are spaced to cover 70 square feet or less.

(h) In lieu of complying with the provisions of Section ANSI/NFPA 13 of Reference Standard RS 17-2 of the Administrative (Building) Code, a 1 inch valve pipe may be extended from the top of the riser to the outside of the building, or inside the building to a deep sink for testing the system, pump and alarm under water-flow conditions.

(i) Check valves, gate valves, and water meters shall be installed as and when directed by the Department of Environmental Protection.

(j) The term "sprinkler area" as used in these rules shall mean any floor space within a structure enclosed on all sides by *[sic]* exterior walls, fire walls, fire partitions, or fireproof *[sic]* partitions and self-closing doors acceptable to the Department of Buildings.

(k) The sprinkler control valve shall be inspected at least once weekly by a competent person, who is employed by the owner to see that such valves are sealed open, and who holds a certificate of fitness. A record of each inspection shall be kept for examination by a representative of the Department.

The provisions of §27-957, in relation to alarm devices, shall not apply to those buildings having not more than 36 heads in any sprinkler area.

(l) Where there are practical difficulties in the way of carrying out these rules, the Superintendent may permit modification, provided that the spirit of these rules are observed and safety secured.

§29-06 Installation of Automatic Sprinklers in the Public Halls of Multiple Dwellings Under the Provisions of §187 (Converted Dwellings) and §218, Subdivision 5 (Old-Law Tenements), of the Multiple Dwelling Law, and of the Sprinklers in Cooking Spaces in all Types of Multiple Dwellings Under the Provisions of §33 of the Multiple Dwelling Law.

(a) *Certification from the Department of Environmental Protection.* When it is proposed to supply a sprinkler system by means of a direct connection to a public water supply main, the specifications shall be accompanied by a letter or other approved certification from the Department of Environmental Protection, establishing the fact that the water supply conditions and pressure are such that will meet the requirements of these rules for water supplies for sprinklers.

(b) *Type of system required.*

Sprinkler system shall be of the automatic wet type.

(c) *Connection to water main.*

The sprinkler system of each building shall have a separate and independent source of supply except as herein otherwise specifically provided. When a sprinkler system is supplied direct from a public water main, it shall be separately and independently connected to the public water main except that one street main supply will be accepted for not more than three contiguous buildings under one ownership where such buildings are separated by fire walls, provided that the supply is brought into the center building of a group of three, and provided further, that the supply shall be adequate for the total number of sprinklers in any two buildings, but not less than 50 percent of the total number of sprinklers in all the buildings in any case. In all other respects, the installation in each building shall comply with these rules.

When one street supply serves more than one building, there shall be submitted to the department evidence that *[sic]* an easement has been created in favor of each building for the continued use of such supply for each building.

A house service water supply connection may be taken from the sprinkler water supply connection to the city main, on the house side of the main shut-off valve for the building provided the diameter of the house service water supply connection does not exceed one-half of the diameter of the sprinkler water supply connection. Only one connection of the domestic water supply to the sprinkler water supply line shall be permitted and no shut-off valve shall be placed on the sprinkler supply line, other than the main shut-off valve for the building on the street side of the house service water supply connection. (§29-06(c) amended by resolution filed with City Clerk February 9, 1956.)

(d) *Water pressure and supply.*

Water supply from public water mains will be acceptable when such supply will provide a minimum static pressure at the highest sprinkler of not less than 15 pounds per square inch. For computation of the required water pressure at the curb

Rules and Regulations

level to provide adequate pressure at the highest sprinkler, the following formula shall be used:

Required water pressure in pounds per square inch = 0.434 H plus 15.

Where H = height in feet from the curb level to the level of the highest sprinkler.

When the minimum pressure in the water supply is insufficient to provide the required pressure, but is capable of [sic] providing a pressure of not less than five pounds per square inch at the highest sprinkler, an automatic centrifugal booster pump for the purpose of increasing the water pressure will be accepted under the following conditions:

(1) The rated capacity of the pump shall be not less than 250 gallons per minute and shall be sufficient to supply at least 25 percent of the total number of sprinklers, or where there is insufficient pressure in the top story only, all the sprinklers on the top floor, at the rate of 20 gallons per minute per sprinkler. A 2 1/2-inch diameter test tee shall be attached to the discharge pipe from the pump for the purpose of testing its capacity.

(2) There shall be a pressure regulator attached to the pump which shall be set so that the pump will automatically start operating when the water pressure at the highest sprinkler falls below 20 pounds per square inch, and cease to operate when the said pressure reaches 30 pounds per square inch.

(3) The pump shall be attached on bypass properly valved to the sprinkler main on the house side of the main control valve. The intake and discharge pipes to the pump shall be of sufficient size to deliver the required volume of water to the system at the stated minimum pressure.

(4) Drain valves shall be installed on the main between the main (O.S.&Y.) control valve and the intake connection to the pump and on the house side of the discharge connection to the pump. Such drain valves shall be closed by means of screw plugs.

(5) A check valve shall be installed on the main on the inside service between the intake and discharge connections to the pump.

(6) The intake and discharge pipes from the pump shall each be provided with an O.S.&Y. valve.

(7) A variation of not more than two pounds per square inch, in the minimum pressure, in the street supply below the required pressure for the sprinkler system without the introduction of a booster pump or increased size in piping may be accepted by the Superintendent if in his opinion the supply is adequate.

There shall be sufficient actual water volume to supply 25 percent of the heads for a period of 20 minutes at 20 gallons per minute.

(e) *Roof tanks.*

Except as otherwise specifically provided in §29-06 (d), a gravity tank upon the roof will be required when the normal minimum water pressure from the public water main is insufficient. The bottom of each gravity tank supplying a sprinkler system shall be elevated at least 20 feet above the roof.

Each gravity tank shall be filled through a fixed water supply pipe of at least one and one-half inch diameter and independent of the sprinkler pipe system, by means of an automatically controlled pump of a capacity at the discharge nozzle of the pump of at least 65 gallons per minute against the total head, including friction. The tank fill line shall be standard weight pipe, galvanized steel, brass or copper [sic] pipe. The pump shall be equipped with control apparatus which will automatically start operation when the effective capacity of the tank falls below the minimum reserve supply for the sprinkler system.

A gravity tank, if used exclusively to supply the sprinkler system, shall have an effective capacity of not less than fifteen hundred (1500) gallons. Gravity tanks which serve both the house supply and the sprinkler system shall have an effective capacity of not less than twenty-five hundred (2500) gallons with a minimum of fifteen hundred (1500) gallons reserved for the sprinkler system.

All exposed water supply piping connecting with roof gravity tanks shall be properly protected against freezing by four layers of one inch high-grade hair felt, and each layer of hair felt shall be covered with a layer of heavy tar paper.

Each wrapping shall be securely fastened with heavy twine, and wrapping joints shall have a lap of not less than two inches staggered into the laps of the adjacent layers.

All coverings shall be finally covered with heavy canvas sewed at seams and painted with two coats of waterproof paint.

In lieu of the foregoing, three inch thick fiberglass in a metal shield may be used.

Exposed gravity tanks on the roof shall be protected against freezing by means of an approved enclosure, insulation, heating coil or other means acceptable to the Superintendent.

Gravity tanks shall be supported in accordance with the provisions of §P107.8 of Reference Standard RS-16 of the Administrative (Building) Code.

Gravity tanks shall be provided with emergency outlets in conformity with §P107.8 of Reference Standard RS-16 of the Administrative (Building) Code.

(f) *Pressure tanks.*

Except as otherwise specifically provided in §§29-06(d) and (e), a pressure tank will be required when the normal minimum water pressure from the public main is insufficient. Such pressure tank may be installed in the basement or cellar.

Pressure tanks when used shall be capable of supplying actual water volume as required in §29-06(d) of these rules at a pressure of not less than 15 pounds per square inch. Pressure tanks shall be constructed and tested in accordance with the requirements of ANSI/NFPA 22 of Reference Standard RS 17-10 of the Administrative (Building) Code.

Pressure tanks shall be at least two-thirds filled with water and an air pressure by gauge shall be maintained in the tank of not less than 75 pounds plus the pressure caused by the column of water in the sprinkler system above the bottom of the tank.

At the end of each pressure tank there shall be a glass water-level gauge, and the pressure tank shall also be provided with a pressure gauge and a manhole for access to the interior of the tank.

The filling pump for the pressure tank shall have a capacity of not less than 65 gallons per minute against the total head including friction and air pressure of the tank. The compressor shall be powered by an electric motor which shall be equipped with control apparatus, which will automatically start the motor when the pressure in the tank drops to 75 pounds per square inch and will cut out the motor when the pressure in the tank reaches the total required pressure. The air compressor shall be capable of delivering not less than 10 cubic feet of air per minute. The filling pipe from the pump or air compressor shall be provided with a relief valve set to open at 15 pounds in excess of the maximum air pressure required in the tank.

(g) *Sprinkler pressure, where required.*

Sprinklers shall be arranged to spray all parts of the public stairways, service stairways, their hallways, landings and soffits.

Rules and Regulations

Sprinkler protection shall be provided also in each closet opening on a public hall and in any permanent telephone booth placed in a public hall, but no sprinkler protection shall be required in any bathroom, water closet [*sic*] compartment or shower room opening upon a public hall.

There shall be two or more sprinklers installed under the soffit of each public stairs spaced not more than fourteen (14) feet apart. Sprinklers shall be provided over and under the stairway leading from the basement or cellar to the first floor, except that where the under part of the cellar stairway is completely enclosed with fireproof material, sprinklers will not be required under the soffit of such cellar stairway.

Sprinkler protection shall be provided in spaces exceeding three (3) feet in height, above a public hall between the ceiling of the top story and the roof unless such spaces are properly cut off from the public hall by means of fire retarded partitions.

Sprinkler protection shall be provided also on the underside of public stairhalls, stair landings and soffits which are not within stair enclosures except when such surfaces are fire-retarded.

Sprinklers shall not be required in roof bulkheads or in unheated outside street vestibules.

Sprinkler protection shall not be required in any auxiliary stairway extending from the lowest story to the next higher story above, on condition that such stairway is not located under any stairway leading to upper stories nor terminates in a public hall.

Deflectors of sprinklers shall be placed not less than three inches nor more than ten inches below ceilings or soffits.

Sprinklers shall not be located within 12 inches distance of any obstruction such as hanger, lighting fixture, etc.

(h) Tap sizes required.

Taps connecting to public water mains shall be equal in size to the main pipe line, except that:

A two and one-half inch tap connecting to the public water main and immediately increased to three inches in diameter, with piping of the same diameter extending into the building, shall be considered the same as a three inch direct connection to the public water main.

A two inch tap connecting to the public water main and immediately increased to two and one-half inches in diameter, with piping of the same diameter extending into the building, shall be considered the same as a two and one-half inch direct connection to the public water main.

A one and one-half inch tap connecting to the public water main and immediately increased to two inches in diameter, with piping of the same diameter extending into the building, shall be considered the same as a two inch direct connection to the public water main.

(i) Pipe schedules.

Except as otherwise provided in this section, the number of sprinklers on a given size of piping shall not exceed the following:

| Diameter of Pipe | Maximum number of sprinklers allowed |
|------------------|--------------------------------------|
| 1 inch pipe | 2 sprinkler heads |
| 1 ¼ inch pipe | 3 sprinkler heads |
| 1 ½ inch pipe | 5 sprinkler heads |
| 2 inch pipe | 10 sprinkler heads |
| 3 inch pipe | 30 sprinkler heads |
| 4 inch pipe | 60 No Limit |

The sprinkler main shall not be less in size than the sprinkler riser and shall not be less in size than any branch it serves.

Except as otherwise specifically provided in §29-06(h), the total number of sprinklers in a structure shall determine the required size of the tap, service main, risers and branches, but in no case shall the size of the main supply be less than two inches

The following sprinklers will not be counted in computing the size of the taps, mains and risers:

(1) One sprinkler of the required sprinklers placed under the soffits of the stairs in each story when more than one sprinkler is provided.

(2) Sprinklers placed in any closet or telephone booth opening upon a public hall.

(3) Sprinklers placed (in lieu of fire retarding) on the underside of public stairhalls, stair landings and soffits not within the stair enclosure.

The permissible number of heads may at the discretion of the Superintendent be increased by not more than 10 percent.

(j) Siamese.

A sprinkler system containing 55 or more sprinklers in one building or fire area, shall be provided with an approved Fire Department Siamese Connection installed in accordance with §27-940 of the Administrative (Building) Code.

(k) Sprinklers in existing cooking spaces.

When a sprinkler is installed in the ceiling over an existing cooking space, pursuant to §33 of the Multiple Dwelling Law, the sprinkler shall be connected with the domestic water supply of the building through a pipe of at least one inch diameter, at a point either side of the valve controlling the supply to the plumbing fixture in the cooking space. There shall be at least one sprinkler for every 49 square feet or fraction thereof of the floor area of the cooking space. Such sprinklers shall not be included in the computations for determining the size of the sprinkler piping or the necessity of a siamese as outlined in §§29-06(i) and 29-06(j).

No sprinkler shall be installed in a cooking space without a written approval from the Department of Buildings. The Superintendent may, however, waive the requirement as to the filing of the plans when, in his opinion, the nature of the alteration may be fully explained in the application.

(l) Valves.

Each valve controlling water supply and each valve controlling drainage of system or test flow, shall bear a metal plate securely attached to the valve and indicating clearly the purpose of each such valve.

On the sprinkler main, an outside screw and yoke gate valve, readily accessible, shall be provided near the front wall of the building and located so as to control the water supply to all of the interior sprinkler system. The said outside screw and yoke gate valve shall be sealed in an open position.

If a roof tank is used as a supply for sprinklers, an outside screw and yoke gate valve shall be provided in the piping leading from the tank to the sprinkler system, under conditions similar to those specified for such valves on sprinkler mains.

A check valve of equal diameter to the main shall be installed in all sprinkler mains where a building is supplied by services connected to different street mains, or where a building is equipped with a siamese connection. Such check valve shall be placed within two feet of the outlet side of the main control valve.

Rules and Regulations

Where a sprinkler system is supplied with both a gravity tank and a street main, a check valve shall be placed in the independent supply pipe to the tank (on the tank side of the pump) and in the main at the outlet end of the main control valve. Such check valves shall be of equal diameter to the supply pipe and the main respectively.

When the sprinkler system has an auxiliary supply in the form of a siamese connection, a check valve shall be placed in a horizontal position in the down feed from the gravity tank and immediately below the roof.

When a building is supplied through a pressure tank in the cellar or basement, a check valve of equal diameter to the main shall be placed in the sprinkler main on the inside service between the intake and discharge connections to the pump feeding the pressure tank.

Where a sprinkler system is equipped with a booster pump, valves shall be provided in accordance with §29-06(d).

All control valves in supplies to the sprinkler system shall be sealed in an open position in an approved manner.

Where an underground main is used, the main control valve shall be located where readily accessible.

(m) *Drainage.*

All sprinkler pipe and fittings shall be so installed that the system can be thoroughly drained. Where practicable, all piping shall be arranged to drain to the main drain valve. Where this is impracticable, as in the case of sprinkler piping under stair soffits, a three-quarter inch screw plug shall be provided in the lower end of such piping to permit drainage.

Except where otherwise provided in the previous paragraph, sprinkler pipes shall be pitched not less than one-quarter inch in the 10 foot Pipe shall be straightened before installation to prevent pockets which would interfere with proper drainage.

For draining the sprinkler system, a three-quarter inch tee branch with a three-quarter inch plugged valve shall be provided on the sprinkler main on the house side of the main (O.S.&Y.) control valve.

Where a sprinkler system is provided with check valves, the intermediate pipe between check valves shall be so arranged as to properly drain.

(n) *Sprinkler specifications.*

Sprinklers shall be of a type and manufacture approved by the Board of Standards and Appeals and of current issue.

The operating temperature of all sprinklers shall be in the ordinary degree range. Appropriate higher degree operating temperatures shall be required in cooking spaces.

Any sprinkler which has opened or has been damaged shall be replaced immediately with a good sprinkler.

There shall be kept available on the premises at all times at least three extra sprinklers and also a sprinkler wrench for use to replace any fused or damaged sprinklers.

(o) *Pipe specifications- sleeves.*

All piping except underground piping used in sprinkler systems shall be full weight standard steel threaded pipe, well reamed and screwed up tight into fittings without reducing the waterway. Fittings shall be standard weight cast-iron. All fittings and pipes placed inside of tanks shall be of brass or other non-corroding material.

Underground piping shall be of Extra Heavy Cast Iron Corporation pipe with bell and spigot [*sic*] or mechanical joints.

Sprinkler piping passing through floors (other than floors in

public halls) of concrete or waterproof construction, shall have properly designed substantial thimbles or sleeves projecting three to six inches above the floor to prevent possible floor leakage.

The space between the pipe and sleeve should be caulked with oakum or equivalent material. If floors are of cinder concrete, thimbles or sleeves should extend all the way through to protect the piping against corrosion.

(p) *Hangers and support of piping.*

All branches shall be adequately supported. There shall be at least one hanger for each length of pipe between sprinklers, with one hanger within 30 inches of the end sprinkler and with hangers not over 12 feet apart.

Vertical piping shall be securely supported at the base and at maximum intervals of every other floor, provided that such maximum intervals are 20 feet or less.

The maximum spacing between hangers on horizontal mains and risers shall be twelve 12 feet

Hangers shall be of a substantial metal type.

Sprinkler risers shall not be located within 12 inches of a window or other exterior wall opening.

(q) *Frost protection.*

When necessary for the protection of a sprinkler system against frost, the Superintendent shall require that the public halls be heated.

Exposed water supply piping shall be protected against frost in accordance with §29-06(e).

(r) *Tests.*

Sprinkler systems when completed shall be subjected to a hydrostatic test at a pressure of not less the thirty 30 pounds per square inch in excess of the normal pressure required for such sprinkler system when in service, except that where a siamese is required, the test pressure shall be not less than 200 pounds per square inch.

All piping shall remain uncovered in every part until it has successfully passed the test.

The Department of Buildings, in the borough in which the test is to be conducted, shall be notified when such test is to take place. Tests shall be conducted by the contractor or the owner or the owner's representative, in the presence of a representative of the Building Department.

Sprinkler risers shall be provided at the top for testing purposes, with a connection not less than one inch in diameter, with a valve outlet so located that same will be readily accessible at all times. When not in use the valve shall be provided with an iron or brass plug screwed in tight.

(s) *Maintenance.*

Each sprinkler system shall be maintained in good condition and in such manner that it will function effectively in the event of fire on the premises.

The owner is responsible for the condition of his sprinkler system and shall use due diligence in keeping the system in good operating condition.

Sprinkler systems shall be inspected at least once in each six months by the owner, to ascertain that all parts of the system are in perfect working order. A detailed record of each such inspection shall be kept on the premises for examination by the Department of Housing Preservation and Development, the Department of Buildings and the Fire Department.

(t) *Painting.*

When the sprinkler system is given any kind of coating, such

Rules and Regulations

as whitewash or paint, care shall be exercised to see that no portion of the automatic sprinklers is covered.

(u) *Alterations.*

No additional sprinklers shall be installed and no part of a sprinkler system shall be altered without a written approval from the Department of Buildings.

(v) *Issuance of approval.*

Before the installation of a sprinkler system is approved and prior to the issuance of a letter of approval, there shall be filed with the Department of Buildings, in the borough in which the work has been installed, a letter from the Department of Environmental Protection indicating the size of the tap and service main and whether same has been installed in an approved manner.

§29-07 Installation of Wet-Pipe Sprinklers.

Rules and Regulations for the Installation of Wet-Pipe Sprinklers under the provisions of §248, Subdivision 4, Paragraph b, Multiple Dwelling Law, in Certain Fireproof Multiple Dwellings Erected before May 16, 1913, and Converted in Whole or in Part to Single Room Occupancy Prior to December 9, 1955.

Extract from the Multiple Dwelling Law Section 248, Subdivision 4, Paragraph b. "There shall be access to a second means of egress within the apartment without passing through any public stair or public hall. On and after July first, nineteen hundred fifty-seven, every tenement used or occupied for single room occupancy in whole or part under the provisions of this section, and which does not have at least two means of egress accessible to each apartment, and extending from the ground story to the roof, shall be provided with at least two means of egress or, in lieu of such egress, every stair hall or public hall, and every hall or passage within an apartment, shall be equipped on each story with one or more automatic sprinkler heads approved by the department. Elevator shafts in such tenements shall be completely enclosed with fireproof or other incombustible material and the doors to such shafts shall be fireproof or shall be covered on all sides with incombustible material."

(a) Except as otherwise provided herein, automatic wet-pipe sprinklers installed under the provisions of §248, Subdivision 4, Paragraph b, Multiple Dwelling Law, in certain fireproof multiple dwellings erected before May 16, 1913, and converted in whole or in part to single room occupancy prior to December 9, 1955, shall be installed in conformity with Subchapter 17 of Chapter 1 of Title 27 of the Administrative Code.

(b) In lieu of one of the four alternate automatic sources of water supply specified in §27-961, Subdivision b, of the Administrative (Building) Code, a connection may be made to the domestic water supply system under the following conditions:

(1) It can be established from the information obtainable from the Department of Environmental Protection that the minimum static pressure at the top of the highest riser will be at least 15 pounds per square inch except as otherwise provided in §29-07(g).

(2) If the pressure from this source is insufficient to provide a minimum static pressure of 15 pounds per square inch at the highest line of sprinklers, but is sufficient to supply a pressure of 5 pounds per square inch or more at the highest line of sprinklers, an automatic booster pump shall be provided, the capacity of which shall be 250 gallons per minute at a pressure of at least 15 pounds per square inch at the highest sprinkler line.

(3) A sprinkler shut-off valve is provided conveniently accessible, and its purpose is clearly indicated by the words "Automatic Sprinkler Shut-Off Valve" on a sign affixed thereto, and that such valve is sealed open.

(4) The size [*sic*] of the domestic water supply line is at least equal to the size of the main sprinkler connection.

(5) The provisions of Paragraph c, of §27-964 shall not apply to sprinklers installed in conformity with the provisions of this §29-07(b).

(6) Where the length of pipe from the furthestmost sprinkler to the riser exceeds 100 feet, the pipe beyond the 100 foot distance shall be increased in size one pipe size above the size of otherwise required, for each 100 feet of additional length or part thereof. This provision shall not require an increase in the size of the risers.

(c) The capacity of [*sic*] gravity tanks for sprinklers shall be in conformity with provisions of §27-965, or such tank may be supplied by an automatic filling pump, capable of delivering at least 65 gallons per minute to the tank and shall have sufficient capacity to supply 25 percent of the sprinkler heads in the largest sprinkler area for 20 minutes, at 20 gallons per minute. The capacity of such tank shall not be less than 1,500 gallons. The bottom of the gravity tank or the sprinkler supply pipe shall not be less than 20 feet above the highest supplied sprinkler line. When such elevation is not practicable, an automatic booster pump may be installed in the main sprinkler supply line in conformity with paragraph b of §29-07(b)(2).

(d) In lieu of complying with the provisions of §27-965, a pressure tank located not more than one story below the highest supplied sprinkler line, filled by an automatic pump, and with a supply of water, all as described in §29-07(c), may be installed. In addition, a high-and-low air-alarm shall be provided.

(e) Subdivision b of §27-963(a) may be construed to permit the sprinkler connection to the street main to be the same size as the main sprinkler riser, but in no instance shall it be less than 2 inches. A tap may be one pipe-size less than the sprinkler main.

(f) When the number of sprinkler heads in any fire area as defined in these rules exceeds fifty-five (55), an approved Fire Department siamese connection shall be installed in accordance with the requirements of §27-940 of the Administrative (Building) Code.

(g) In lieu of applying the provisions of §27-956, sprinkler heads shall be so spaced that there shall be one head for approximately 144 square feet of floor area, and heads shall be spaced not more than 14 feet on centers. The distance from a wall or partition to the first sprinkler head shall not exceed 7 feet, measured at right angles to the wall or partition. A 12-pound minimum static pressure will be accepted at the topmost sprinkler line, provided the sprinkler heads are spaced to cover 100 square feet or less.

(h) In lieu of complying with the provisions of ANSI/NfPA [*sic*] 13 of Reference Standard RS 17-2 of the Administrative (Building) Code, a 1-inch valve pipe may be extended from the top of the riser to the outside of the building, or inside the building to a deep sink for testing the system, pump and alarm under water-flow conditions.

(i) Check valves, gate valves, and water meters shall be installed as and when directed by the Department of Environmental Protection.

(j) *Definition. Sprinkler area.* The term "sprinkler area" as used in these rules shall mean any floor space within a structure

Rules and Regulations

enclosed on all sides by exterior walls, fire walls, fire partitions, or fireproof [sic] partitions and self-closing doors acceptable to the Department of Buildings.

(k) The sprinkler control valves shall be inspected at least once weekly, by a competent person, who is employed by the owner and who holds a Certificate of Fitness to see that such valves are sealed open. A record of each inspection shall be kept for examination by a representative of the Department. The provisions of §27-957, in relation to alarm devices, shall not apply to those buildings having more than 36 heads in any sprinkler area.

(l) In conformity with the provisions of §27-957, sprinkler alarm devices shall be required when more than 36 heads are installed in any fire area.

(m) Where there are practical difficulties in the way of carrying out these rules, the Superintendent may permit modification, provided that the spirit of these rules are observed and safely secured.

§29-08 Installation of Sprinklers in Rooms of Class B Non-Fireproof Converted Dwellings and in Rooms Used for Class B Occupancy in Non-Fireproof Class A Converted Dwellings Under the Provisions of §194 of the Multiple Dwelling Law.

(a) *Applicability.* Sprinklers installed in rooms of class B non-fireproof converted dwellings, and in rooms used for class B occupancy in non-fireproof class A converted dwellings shall conform to the "sprinkler rules governing the installation of automatic sprinklers in the public halls of multiple dwellings. Under the provisions of §187 (Converted Dwellings) and §218(7) (Old Law Tenements) of the Multiple Dwelling Law, and of sprinklers in cooking spaces in all types of multiple dwellings under the provisions of §33 of the Multiple Dwelling Law," except as provided otherwise in these rules.

(b) *Sprinkler protection-when required.* In every room in a class B non-fireproof converted dwelling, and in every room used for class B occupancy in any non-fireproof class A converted dwelling, there shall be one or more sprinkler heads so arranged as to sprinkle all parts of such rooms. A sprinkler system in the public stairway or in the service stairway shall not be required by these rules, but sprinklers shall be provided for such stairways where required by the Multiple Dwelling Law or the provisions of other rules.

(c) *Spray type sprinklers.* Where approved spray type sprinkler heads are used, they shall conform to the requirements of the rules specified in subdivision (a) of this section, except that the protected area for approved 1/2 inch spray type sprinklers shall not exceed 168 square feet in area, and the distance between heads shall not exceed 14 feet and the maximum distance between such heads and a wall or partition shall not exceed 7 feet

(d) *Connection to existing sprinkler systems.* Where a separate sprinkler system exists in a building and such sprinkler system was installed prior to December 15, 1956, and the sprinkler system was approved by the Department of Buildings and is in good operating condition, piping for the sprinklers in rooms may be taken from the existing sprinkler riser at each story, provided the riser has a diameter of not less than one inch. The size of the branch piping between the sprinklers and the riser shall be determined according to the number of sprinklers supplied but shall not be required to be greater in size than 1 1/4 inches in diameter, except that if the length of pipe exceeds 50 feet, the entire length of pipe shall be increased one pipe size for each 50 feet of length. Existing risers and mains of sprinkler systems shall not be required to be increased. The sprinkler heads

installed in rooms shall not be counted in determining whether a siamese hose connection is required.

(e) *Installation where no sprinkler system exists.* Where it is required that sprinklers be provided in rooms and there is no existing approved sprinkler system in the building, a system of sprinklers shall be provided which shall conform to the requirements of the rules specified in subdivision (a) of this section and to the requirements of these rules in the same manner as if such sprinklers were existing except that mains shall be not less than 1 1/4 inches in diameter and that a siamese hose connection shall not be required, and except as follows: Where the existing water supply piping is tested at any location within the dwelling and discharges at least 20 gallons of water per minute, at a flow pressure of not less than 10 pounds per square inch at the point of delivery, the existing house water supply main may be used provided the diameter of the main is not less than 3/4 inch, and provided a static pressure of at least 15 pounds per square inch is provided at the highest sprinkler. In such case, a riser for the sprinkler system shall be connected to the water main not more than 12 inches from the point where the main enters the building and on the house side of the main house control valve. No additional branch control valves shall be permitted. The size of the riser shall be determined by the number of sprinkler heads as required by the rules specified in subdivision (a) of this section, except that the riser shall not be required to be more than 1 1/4 inches in diameter regardless of the number of sprinkler heads provided. The size of branches shall be determined by the number of sprinkler heads, except that branches shall not be required larger than 1 1/4 inches in size. Risers and branches provided for the sprinkler system shall be used for no other purpose.

§29-09 Installation of Chlorinated Poly Vinyl Chloride (CPVC) Sprinkler Pipe and Fittings.

(a) Storage and Handling

CPVC piping shall be stored and carried in the original shipment containers whenever possible. Reasonable care should be exercised in handling the pipes. If improper handling results in splits, gouges or cuts and scratches that are not superficial in nature, the damaged section shall be cut out and discarded. Pipes must be covered with non-transparent material when stored outdoors without the original containers.

(b) Safety Precautions

All solvent cements and primers for CPVC piping are flammable and shall not be used or stored near heat, spark or open flames. Cement shall be stored in closed containers at temperatures between 40 °F (4.4 °C) and 110 °F (43 °C). They shall be used only with adequate ventilation. Containers shall be kept tightly closed when not in use and covered as much as possible when in use.

(c) Certification

Individuals installing CPVC piping shall be trained and certified by the manufacturer. Documentation of such certification of the individual shall be on the job site at all times when installation work is performed.

(d) Installation

(1) General

Sprinkler piping systems shall be laid out so that the piping is not located adjacent to heat producing sources such as light fixtures and ballasts, steam lines, etc. which can produce an ambient temperature exceeding 150 °F (66 °C). CPVC pipes shall not be threaded, grooved or drilled.

(2) Concealed Installation

(i) For concealed installation, the minimum protection

Rules and Regulations

shall consist of one layer of 3/8" (10mm) gypsum wallboard or a suspended membrane ceiling with lay-in panels or tiles having a weight of not less than 0.35 pounds per square foot (1.71kg/m²) when installed with metallic support grids, or 1/2" (13mm) plywood pipe enclosure. Plywood used for pipe enclosure shall be fire-retardant treated when used in buildings of non-combustible construction.

(ii) When pipes and fittings are installed in a plenum space, they shall not be positioned directly over open ventilation grills.

(iii) System risers shall not be installed exposed, and shall be provided with minimum protection for concealed installation as stated above.

(3) Exposed Installation

(i) Exposed sprinkler piping shall be installed below a smooth, flat, horizontal ceiling construction. Positioning of sprinkler heads relative to obstructions such as, but not limited to, beams, light fixtures or decorations shall be in accordance with Reference Standard RS 17-2, 17-2A and 17-2B.

(ii) Only quick-response sprinkler heads shall be used on exposed piping.

(iii) Deflectors of pendent sprinklers when installed shall be not more than 4" (102mm) from the ceiling, and sidewall sprinklers not more than 6" (152mm) from the ceiling and not more than 4" (102mm) from the sidewall.

(iv) Upright quick-response sprinklers when installed on exposed piping shall meet the following conditions:

(a) The deflectors shall be not more than 4" (102mm) from the ceiling.

(b) The maximum temperature rating shall be 155 °F (68 °C).

(c) The maximum distance from the ceiling to the centerline of the main run of pipe shall be 7 1/2" (191mm).

(d) The maximum distance from the centerline of a sprinkler head to a hanger shall be 3" (76mm).

(4) Hangers and Supports

The pipe hangers shall comply with all the requirements of RS 17-2, 17-2A and 17-2B. The hanger shall not have rough or sharp edges which come in contact with the pipe. Hangers shall not bind the pipe from movement.

| Nominal Pipe Size | | Maximum Support Spacing | |
|-------------------|---------------|-------------------------|----------|
| Inches | (millimeters) | Feet | (meters) |
| 3/4 | (19) | 5 1/2 | (1.675) |
| 1 | (25) | 6 | (1.830) |
| 1 1/4 | (32) | 6 1/2 | (1.980) |
| 1 1/2 | (38) | 7 | (2.135) |
| 2 | (51) | 8 | (2.440) |
| 2 1/2 | (64) | 9 | (2.745) |
| 3 | (76) | 10 | (3.050) |

| Nominal Pipe Size (In) | Maximum Support Spacing Distance | |
|------------------------|----------------------------------|----------------------------|
| | Less than 100 psi (689kPa) | More than 100 psi (689kPa) |
| 3/4" (19mm) | 9" (229mm) | 6" (152mm) |
| 1" (25mm) | 12" (305mm) | 9" (229mm) |
| 1 1/4" (32mm) | 16" (406mm) | 12" (305mm) |
| 1 1/2"-3" (38-76mm) | 24" (610mm) | 12" (305mm) |

| Nominal Pipe Size (In) | Maximum Support Spacing Distance | |
|------------------------|----------------------------------|----------------------------|
| | Less than 100 psi (689kPa) | More than 100 psi (689kPa) |
| 3/4" (19mm) | 4' (1.220m) | 3' (0.915m) |
| 1" (25mm) | 5' (1.525m) | 4' (1.220m) |
| 1 1/4" (32mm) | 6' (1.830m) | 5' (1.525m) |
| 1 1/2"-3" (38-76mm) | 7' (2.135m) | 7' (2.135m) |

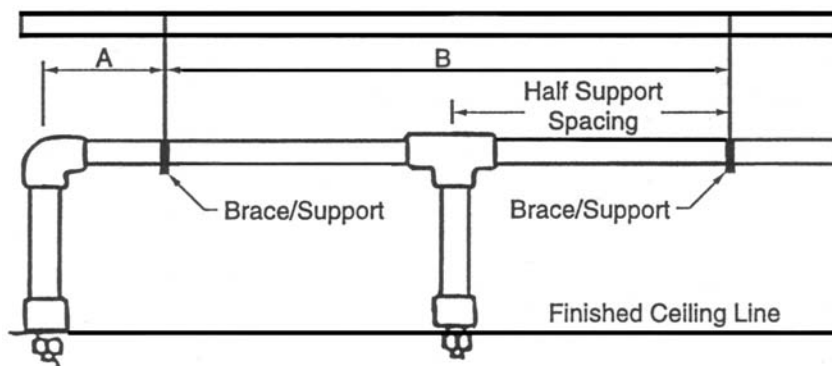

Rules and Regulations

(i) The support spacing shall be as shown on the following tables and diagram:

(ii) Vertical pipes shall be supported at each floor level or at 10 feet (3.050m) intervals whichever is less.

(iii) Other methods of pipe support shall be as recommended by the manufacturer.

(5) Pipe Cutting

Pipes shall be cut with a wheel-type plastic-tubing cutter. If any indication of damage or cracking is evident, cut off at least 2" (51mm) beyond any visible crack. Burrs and filings can prevent contact between pipe and fittings during assembly, and must be removed from the outside and inside of the pipe. A slight bevel shall be placed at the end of the pipe to ease entry of the pipe into the socket.

(6) Pipe Joints

(i) Primer and cement application.

The pipe and fittings shall be clean and free of any moisture and debris. Primer and cement shall be applied to the joining surfaces using an applicator. Puddling of cement or primer on or within fitting and pipe must be avoided. When cementing in temperatures below 40 °F (4.4 °C) make certain cement has not gelled. Gelled cement must be discarded.

A bead of cement should be evident around the pipe and fitting juncture. If this bead is not continuous around the socket shoulder, it should be rejected and the joint must be cut out, discarded and begun again.

(ii) Set and Cure Time

The assembly must be allowed to set, without any stress on the joint, in accordance with manufacturer's recommendations, which may vary from 1 to 5 minutes depending upon the pipe size and temperature. Refer to manufacturer's recommendation for minimum cure times prior to pressure testing.

(7) Sprinkler Installation

Sprinklers shall be installed only after all pipes and fittings, including sprinkler head adopters, are solvent welded to the piping system and allowed to cure for a minimum of 30 minutes. Sprinkler head fittings should be visually inspected and probed with a wooden dowel to insure that the waterway and threads are clear of any excess cement. Only Teflon tape or equivalent approved by the Commissioner shall be used when installing the sprinkler heads. If a leak is detected on the sprinkler head drop when the system is pressure tested, the sprinkler head must be removed and the joint redone before reinstalling the head.

(8) Firestopping

Pipe penetration through fire rated construction shall be firestopped as per Section 27-343 of the Building Code

(e) Hydrostatic Pressure Testing

After the installation is completed and cured, the system shall be pressure tested as per Section 27-967 of the Building Code. Air or compressed gas must never be used for pressure testing.

CHAPTER 30 STORAGE OF CERTAIN WASTE MATERIALS

§30-01 Enclosures of Premises Used for Automobile Wrecking, Storage of Scrap Metal, Junk, Scrap Paper or Rags, Storage of Lumber, and Building Material or Contractors' Yards.

(a) All existing or hereafter established yards or areas used for automobile wrecking, storage of scrap metal, junk, scrap paper or rags, including sorting of same, storage of lumber

and other building materials, and open contractors' yards, unless the use is conducted entirely within a building enclosed on all sides, shall be completely enclosed by a solid fence or wall, of suitable uniform material and color at least eight feet high conforming to these Rules, the Administrative Code and the applicable provisions of the Zoning Resolution.

(b) Fences or walls shall be constructed or painted uniformly with one color.

(c) No material or racks shall be placed outside of, nor extend above the height of, the enclosing wall or fence.

(d) Fences and walls shall be maintained in good condition and appearance, and weakened or broken parts shall be repaired or replaced. Where paint has peeled or weathered to disclose the material under the paint or where the paint is dirty or faded, the wall or fence shall be repainted. Paint shall cover completely the material underneath.

(e) Walls or fences shall not encroach upon the public street nor upon the adjoining property.

(f) The following establishments are exempt from the requirements of these Rules:

(1) Electrical, glazing, heating, painting, paper hanging, plumbing, roofing or ventilating contractors' establishments, open or enclosed, with open storage limited to 5,000 square feet of lot area.

(2) Fuel, ice, coal or wood sales, open or enclosed, limited to 5,000 square feet of lot area per establishment.

§30-02 Open Lots Used for Storage or Sale of Motor Vehicles.

(a) *General.* (1) (i) These Rules shall apply to all open premises used for the storage or sale of more than four motor vehicles except as otherwise noted, including public parking lots, motor vehicles sales lots, accessory open parking spaces, etc. hereafter established and to all such existing premises hereafter enlarged or changed in location.

(ii) Before any premises is occupied for the storage or sale of motor vehicles, plans or diagrams and [*sic*] application shall be filed with the Department of Buildings by an applicant and a Certificate of Occupancy obtained from the Department. Application shall be made on forms furnished by the Department. Such Certificate of Occupancy shall contain inter alia, the maximum number of vehicles to be accommodated and the type of vehicle (private passenger or commercial).

(2) An application for or including an open parking lot shall be accompanied by a plan showing:

(i) dimensions of the plot and its location in relation to adjoining streets;

(ii) any structure existing or to be erected on the plot;

(iii) the relative elevations of the parking area, curbs and adjoining yards or courts;

(iv) the nature of the walls of adjoining structures, if any, i.e., whether masonry, frame, metal, etc.;

(v) retaining walls to be built;

(vi) retaining walls and open spaces, if any, on adjoining premises;

(vii) existing curb cuts and fences;

(viii) method of providing drainage of the lot;

(ix) material used to surface lot;

(x) etc. The applicant shall also submit such other information as may be requested by the Commissioner.

3. (i) Construction of curb cuts and sidewalks shall comply with the provisions of §27-558 of the Administrative Code.

Rules and Regulations

No Certificate of Occupancy shall be issued unless a drop curb permit has been obtained.

(ii) Curb cuts must be a minimum of five feet from the intersection of two street lines.

(iii) For passenger vehicles with a capacity of not more than nine persons, the minimum width of a curb cut shall be 10 feet including splays, and the minimum width of all entrances and driveways leading to parking spaces shall be eight feet. For all other motor vehicles the minimum width of all driveways shall be 10 feet.

(iv) No motor vehicle may be stored or parked in any location where it would obstruct a required window or required exit.

(4) Openings in enclosures shall be restricted to vehicular entrances and exits on the street frontages. The width of a vehicular entrance and exit shall not exceed the length of the curb cut plus eight feet on each side or 46 feet, whichever is smaller.

(5) (i) Open parking lots shall be graded to conform approximately to the elevation of the abutting sidewalks and properties and shall be maintained so that no drainage will flow onto abutting sidewalks and adjoining properties. Grade separation between the parking lot and properties may be established if masonry retaining walls approved by the Commissioner are installed.

(ii) No resurfacing of porous surfaces shall be done which would increase the thickness to more than 1 1/2 inches after compaction. Maintenance repairs to maintain level surface or to insure adequate drainability of porous surfaces shall be preceded by breaking up and removal of existing asphaltic concrete. The Commissioner of Buildings may require suitable tests to be submitted of the materials used.

(iii) The entrance and exit driveways between the curb line and the open parking lot shall be paved in accordance with the provisions of §27-558 of the Administrative Code. The width of the driveway shall be the width of the opening in the enclosure.

(6) A sign which does not comply with all the requirements of the Administrative Code and the Zoning Resolution shall not be erected or maintained. Signs which may be erected shall be made secure, neatly lettered and properly maintained.

(7) (i) An open parking lot shall be occupied and used for the purpose stated on the Certificate of Occupancy; no other use, occupancy or service shall be conducted on the premises.

(ii) Space used for parking shall be entirely within the lot lines of the premises. Vehicles shall not encroach upon the sidewalks. Where a zoning restriction limits parking to a portion of the plot, the limit of the parking area shall be defined by a fence, wall, milling or screening erected and maintained to the satisfaction of the Commissioner.

(iii) Every open parking lot shall be maintained in a clean and sanitary condition. The accumulation of rubbish or the storage of any kind of junk or waste is prohibited. Where a wood frame shelter, wood fence or railing are permitted, they shall be painted periodically in a [sic] neat, workmanlike manner and shall be properly maintained.

(b) *Additional rules to be applied where there are 10 or more motor vehicles.*

(1) Curb cuts shall conform to the requirements of §27-480(b), except for additional street frontage over 100 feet, there may be an additional curb cut for each 50 feet of frontage or major fraction thereof.

(2) (i) The premises shall have an enclosure on all interior lot lines and on street lines consisting of a substantial woven wire fence, iron picket fence, or masonry wall. A wood fence or railing may be acceptable at the discretion of the Commissioner in sparsely settled areas or outlying sections of the city. All enclosures shall be substantial and at least 4 feet high but may be omitted in cases where masonry walls of adjoining buildings abut the parking space. Such fences shall be installed in a permanent manner.

(ii) Bumpers shall be situated not less than one foot from adjacent property lines [sic] when vehicles are parked parallel to such adjacent property lines. Bumpers shall be situated not less than four feet from adjacent property lines when parked other than parallel to such adjacent property lines.

(iii) A steel guard rail or other substantial barrier designed in accordance with the provisions of §27-558(b) of the Administrative Code which will prevent any part of a vehicle from extending across a property line, may be accepted in lieu of bumpers.

(3) (i) Open parking lots which are to be operated during any portion of the time from 6 p.m. through 6 a.m. shall be adequately illuminated, and the minimum illumination shall be one-tenth of one watt per square foot of parking area, distributed over the entire area. Lights shall be provided with reflectors arranged so that the illumination is directed downward and away from adjacent buildings. Floodlights may also be used where such floodlights do not project light upon adjacent or nearby property.

(ii) For a public parking lot, an attendant's shelter conforming to the Construction Classification I-E of §27-271 of the Administrative Code, 100 square feet or less in area may be erected three feet from a lot line with no fire rating of the exterior walls required. Within three (3) feet, a fire resistive rating of at least two hours is required for the wall nearest the lot line.

(iii) Where there is an attendant's shelter, a copy of the Certificate of Occupancy shall be posted and maintained under glass in the shelter and a copy of the plan or diagram approved by the Department of Buildings shall be kept on the premises. Certified, reduced size, legible copies may be used for this purpose.

(4) Where strict compliance with any of these rules and regulations will create unnecessary hardship or will serve no useful purpose, the Commissioner may modify any part of these rules and regulations in a specific case if, in his opinion, the public health, safety and general welfare will not be endangered thereby, and such modification is in conformity with the general purpose of these rules and regulations.

(c) *Parking lots for four or fewer motor vehicles.*

Where there is hereafter established, provision for 4 or less motor vehicles, the premises shall comply with the applicable provisions of the Zoning Resolution in addition to sections of the above rules numbered (a)(1)(ii), (a)(2), (a)(3)(i), (a)(3)(ii), (a)(3)(iii), (a)(3)(iv)-(a)(5)(i), (a)(5)(ii)-(6)-(a)(7)(i), (a)(7)(ii), (a)(7)(iii)-(b)(4).

(d) *Existing open parking lots.*

Existing Open Parking Lots shall comply with the condition of their prior approval and with sections of the above rules numbered (a)(3)(i), (a)(3)(iv), -(a)(4)-(a)(5)(i), (a)(5)(ii), (a)(5)(iii)-(a)(7)(ii), (a)(7)(iii)-(b)(1)-(b)(2), (b)(2)(ii), (b)(2)(iii)-(b)(3)(i)-(b)(4).

Rules and Regulations

Note: Before any business is conducted on any premises coming within the scope of these regulations, the person conducting or maintaining the business shall obtain such licenses as may be necessary from the Commissioner of Licenses, Department of Consumer Affairs, as required by §20-321 of the Administrative Code.

In addition to compliance with these rules, open parking lots shall comply with applicable provisions of the Zoning Resolution and such other laws as may apply.

The following rules previously promulgated by the Commissioner of Buildings will be repealed:

- (1) Public Parking Lots, Filed with City Clerk October 13, 1964.
- (2) Use of Vacant Land for Outdoor Motor Vehicle Sales Lot, filed with City Clerk April 22, 1955.
- (3) Parking spaces Accessory to Permissible Uses, filed with City Clerk, January 11, 1955.
- (4) Accessory Garages and Parking Spaces for Dwellings, filed with the City Clerk January 22, 1951.
- (5) Open Parking Lots—Proposed Rules as published in November, 1968.

CHAPTER 31 SUSPENSION, REVOCATION OR LIMITATION OF REGISTRATION

§31-01 Suspension, Revocation or Limitation of Registration of Persons Who Present, Submit, Furnish or Seek Approval of Applications for Approval of Plans or Remove Any Documents from the Possession of the Department of Buildings.

(a) *Grounds for revocation, suspension or limitation of registration.* The Commissioner hereby authorizes the Department's Investigations Disciplinary Unit to give notice of a hearing to suspend, revoke or limit the registration of any person registered with the Department pursuant to Administrative Code §27-140.1 where investigation of such person and his or her activities reveals one or more of the following:

- (1) Fraud or deceit in obtaining registration.
- (2) Fraudulent dealings.
- (3) Gross negligence, incompetence, misrepresentation or misconduct relating to the business, trade or calling of the person who is registered.
- (4) Material misrepresentation made to persons not affiliated with the Department regarding the status of applications and/or plans filed with the Department.
- (5) Poor moral character that adversely reflects upon fitness to engage in the activity for which registration is required pursuant to §27-140.1 of the Administrative Code [sic].
- (6) Knowingly or negligently making false or misleading statements to the Department; or knowingly or negligently falsifying or allowing to be falsified any certificate, form, signed statement, application or report filed with the Department, or knowingly failing to submit a report required by law or the Department or willfully impeding or obstructing such submission, or inducing another person to do so.
- (7) The conviction of a criminal offense relating to offering or receiving a bribe, giving or receiving unlawful gratuities, engaging in official misconduct, or other corruption-related acts, where the underlying act arises out of the registrant's occupation or business dealings with the City of New York or with any other governmental entity.

(8) Willful or negligent failure to comply with any rule, order or requirement of the Department of Buildings.

(9) Defacing or destroying Department property, or removing Department property, including permitted folders, from Department premises.

(10) Failure to notify the Department of any change in circumstances of employment, for example, change in employer.

(11) Assisting any exempt individual in the commission of any of the above proscribed acts.

(b) *Procedures for the conduct of a hearing regarding suspension, revocation or limitation of registration.*

(1) After a hearing in accordance with the procedures set forth below, and a determination that evidence supports any one or more of the types of misconduct described in subdivision (a), the Commissioner shall have the power to suspend, revoke or limit registration as provided in §27-140.1 of the Administrative Code and these rules.

(2) The hearing shall be conducted by the Office of Administrative Trials and Hearings (OATH) and governed by the rules of procedure utilized by that tribunal.

(3) After the conclusion of the hearing, OATH shall issue proposed findings of fact and conclusions of law where appropriate, along with a report and recommendation to the Commissioner. The Commissioner shall review the report and recommendation issued by OATH and shall issue a final decision. The Commissioner shall notify the registrant in writing of the Commissioner's decision. Such notice shall include a written statement indicating the reason for the decision.

CHAPTER 32 WALLS

§32-01 The Design and Installation of Curtain Wall and Panel Wall (Non-Loadbearing Exterior Wall) Systems.

(a) *Definition.*

Curtain wall or panel wall system. For the purpose of these rules, a curtain wall or panel wall system shall be defined as an exterior building wall, in skeleton frame construction which carries no roof or floor loads. Panel walls are attached at each story and may be wholly supported at every story or other stories. Curtain and panel walls consist of materials, veneering or assemblies other than loadbearing walls of stone, brick, hollow tile, concrete block, or tile, or combination of them, bonded together with mortar and laid up in place, or of concrete poured in place. Curtain and panel walls may include glass, metal, [sic] stone or masonry elements arranged in such a manner so as not to intentionally exert common action under load. Such elements move independently of each other and the supporting structure.

(b) *Applicability.* These rules and regulations shall not apply where such wall systems or any portion thereof does not extend more than forty feet above legal grade.

(c) *Factors to be considered.* The Licensed Professional Engineer and/or Registered Architect of record shall be responsible for the design of the wall system. The Licensed Professional Engineer and/or Registered Architect may designate such responsibility to other licensed professionals. The Licensed Professional Engineer and/or Registered Architect of record or designee shall provide information to, and cooperate with, the designer for the wall system so that singly or jointly the following factors shall be considered:

- (1) *Movements of the skeleton frame structure.* Care shall be

Rules and Regulations

exercised in the design in order to prevent the transmission of loads from the building structure into any part of the wall system through the connections or adjacent building elements or components. In this regard, the following items shall be amongst those considered:

- (i) Sidesway in buildings over 100 feet in height.
 - (ii) Elastic deformation of members supporting curtain or panel walls such as live load deflections of spandrel beams, differential live load deflections, etc. Short-term and long-term deflection are particularly significant in concrete frames.
 - (iii) Creep and shrinkage of concrete frames.
 - (iv) Thermal movements.
- (2) *Dimensional changes of the building structure and of the curtain wall supports.*
- (3) *Differential [sic] movement involving the building structure and veneer.*
- (4) *Construction and related trade requirements such as:*
- (i) Window supports.
 - (ii) Window washer tracks.
 - (iii) Back-up walls and insulation.
 - (iv) Construction tolerances.
- (5) *Protection against water damage.* In this regard, the following items shall be considered:
- (i) The protection of veneering joints. Care should be taken in the selection of sealants.
 - (ii) The location of expansion joints.
 - (iii) The possibility of a secondary system for controlling water which may enter veneering joints because of design or installation failure, sealant failure, or condensation.
 - (iv) The prevention of trapping water in wall components.
 - (v) The use of lap strips in joints/splices of extrusions.
- (6) *Prevention of failures.* In this regard, the following items shall be considered:
- (i) Specifying performance criteria for veneering.
 - (ii) Testing for water leakage of specimen wall sections.
- (7) *Completeness of architectural drawings.*
- (i) They shall contain adequate details of the wall assemblies.
 - (ii) Termination details of roof and store front.
- (8) *Fabrication, installation and maintenance requirements.*
- (i) Sufficiency of the horizontal and vertical expansion joints for thermal and other building movements.
 - (ii) Fabrication and erection tolerances of the connections.
 - (iii) That the flashing, weep-holes and air circulation have been designed for water defense to prevent uncontrolled water infiltration.
 - (iv) The prevention of electro-chemical reaction (galvanic action) from use of dissimilar metals.
 - (v) The anchoring and supporting system is suitable to the building materials.
 - (vi) The connection design is feasible.
 - (vii) The testing program is feasible and adequate.
 - (viii) The selection of the stone.
 - (ix) The anchor locations, including proper anchor-holes, kerfs, or slots.
 - (x) The transportation and handling requirements. Panelized units shall be handled and transported if possible in the position in which they are going to be anchored on the building. If other positions have to be used during transit, the panels and the stone anchors should be designed for such positions also.
- (d) The general contractor, to whom the work permit is issued, shall be responsible for the fabrication and installation

of the wall system.

The general contractor may retain, designate or sub-contract such responsibility to Licensed Professional Engineers, Registered Architects, construction superintendents, contractors, sub-contractors, and manufacturers.

(1) They shall receive information from, and cooperate with the licensed professionals and designer for the wall system, so that singly or jointly the factors enumerated in §32-01(c) shall be considered in the fabrication and installation.

(2) They shall ascertain that the fabrication and installation of the wall system is done in a safe, workmanlike and generally acceptable manner in accordance with:

(i) The Administrative (Building) Code and the Department of Buildings' Rules and Regulations and Directives and Memorandums.

(ii) The Department of Buildings' Approved Applications and Plans.

(iii) The Contractors' Specifications and developed Plans.

(iv) The Accepted Erection and Shop Drawings.

(v) The Manufacturer's recommendations.

(e) The general contractor, to whom the work permit is issued, or his retainee, designatee, sub-contractor or manufacturer responsible for the wall system shall submit the shop drawings and the computations employed to the Licensed Professional Engineer or Registered Architect of record for their acceptance.

(f) The Licensed Professional Engineer or Registered Architect of record shall review the shop drawings and any computations of the wall system for compliance with plans approved by the Department of Buildings, and with the applicable provisions of the Building Code, its reference standards, and the Rules on Exterior Veneering Materials, adopted by the Board of Standards and Appeals, and he shall certify his approval or acceptance of such shop drawings and computations to the Department of Buildings.

(g) A copy of the shop drawings referred to above, marked approved or accepted by the Licensed Professional Engineer or Registered Architect of record shall be available in the field for use in the installation of the wall system until the application is signed-off as completed by the Department of Buildings.

(h) The general contractor, to whom the work permit is issued or his retainee, designatee, sub-contractor, or manufacturer responsible for the fabrication and installation of the wall system, shall certify to the Department of Buildings that the materials and shop fabrications to be supplied by him are in conformance with the approved or accepted shop drawings and with applicable national standards and §27-132(a) of the Building Code of the City of New York.

(i) The requirements of §§32-01(a) through (f) above shall be complied with before the installation of the wall system is begun.

(j) The installation of the wall system shall be subject to controlled inspection as specified in §27-132(a) of the Building Code. It shall be the responsibility of the person performing the controlled inspection to see that the wall system or its component parts is incorporated into the work in a workmanlike manner and in compliance with the approved or accepted shop drawings.

(k) The controlled inspection field check shall include but not limited to the following:

(1) The supporting structure is:

(i) Properly aligned and within the designed tolerances.

(ii) Without missing or mislocated inserts.

Rules and Regulations

- (2) The framing components are:
 - (i) Properly sized and aligned.
 - (ii) Without missing or mislocated anchoring provisions.
 - (iii) Without structural defects. (In stone, weak seam, hairline cracks, etc.)
- (3) The vision and spandrel lites are not defective.
- (4) Anchors are properly placed, welded, bolted or primed.
- (5) Accepted anchoring or materials are used in lieu of others where there are field changes.
- (6) Weeps and tubes are in place.
- (7) The joinery is properly sealed.
- (8) Accepted sealants with sufficient elongation capability are provided.
- (9) The gaskets meet specifications.
- (10) The end dams are sealed where called for.
- (11) Horizontal and vertical movement joints have been provided.
- (12) "Erection shims", "wedges", mortar draps [*Probably intended "drafts"*] or other material in movement or expansion joints have been removed.
- (13) Observation of unanticipated movements.

(l) The samples submitted to, and marked approved or accepted by the Professional Engineer or Registered Architect of record, consisting of, but not limited to sealants, glass and fasteners shall be available in the field until the application is signed-off as completed by the Department of Buildings.

(m) The alteration of an existing wall system for other than ordinary repairs, whether made voluntarily or as a result of damage, deterioration, or other cause, in its entirety or for a portion thereof, shall be made to comply with the pertinent provisions of Article 12 of Subchapter 10 of Chapter 1 of Title 27 and Reference Standard RS 9-5 and all other requirements of the new Building Code, effective December 6, 1968 as amended and/or the Rules on Exterior Veneering Materials, adopted by the Board of Standards and Appeals, regardless of the percentage which the cost of making the alteration bears to the value of the building.

(n) The Registered Architect or Professional Engineer responsible for controlled inspection shall report unsafe wall system conditions to the Department of Buildings.

(o) The Registered Architect or Professional Engineer responsible for controlled inspection shall submit to the Department of Buildings signed copies of required inspection and test reports (of the work in progress) and comment as to the conformance of material and work to Code requirements.

§32-02 Conditions of a Building's Exterior Walls and Appurtenances That Constitute Conditions Dangerous to Human Life and Safety.

(a) Pertinent conditions.

The following violations are determined to constitute conditions dangerous to human life and safety and are subject to the provisions of Paragraph 3 of Subdivision d of §26-248 of the Administrative Code. Any condition relating to the exterior walls of a building and appurtenances thereof that is designated:

- (1) by an architect or engineer as being in an unsafe condition in the report filed by an architect or engineer with the Department of Buildings pursuant to §27-129 of the Building Code, or

- (2) by personnel of the department as being an unsafe condition upon reviewing the aforementioned [*sic*] report or after having made an inspection of the building.

(b) Civil penalties. Pursuant to §26-248(d)(3) of the

Administrative Code, in the event any person fails to remove any of the violations listed in this rule, after having been served with a notice personally or by certified mail indicating that such conditions exist and requiring removal or compliance, unless the removal of such condition is prevented by a labor dispute or is the result of vandalism beyond the control of the owner, such person shall, in addition to any other prescribed penalty, be liable for a civil penalty of not less than \$150 per day commencing on the date of the service of such notice and terminating on the date that such removal or compliance has been substantially completed. When service of such notice is made by mail to the owner, liability for civil penalties shall commence five days from the date of such mailing.

(c) Discontinuance of action upon removal of violation. Pursuant to §26-248(f) of the Administrative Code where a notice requiring removal of a violation listed in this rule has been issued, liability shall cease, and the Corporation Counsel, on request of the Commissioner of Buildings, shall discontinue prosecution of the civil penalty action only if the removal or compliance so required has been completed or substantially completed within ten days after the service of such notice. The Commissioner shall, upon good cause shown, grant additional time for such removal or compliance. In addition, the civil penalties shall be tolled from the date the owner certifies under oath, on a form prescribed by the Commissioner, that the removal of the violation has been substantially completed. If a subsequent inspection by the department shows a failure to have removed the violation, the civil penalties shall be deemed to have accrued as of the first day a notice of violation has been served.

(d) Explanation. This rule declares that a condition relating to the exterior walls of a building and appurtenances thereof that is designated to be an unsafe condition by an architect or engineer in a report filed pursuant to Administrative Code §27-129 or by personnel of the Department of Buildings, is a condition dangerous to human life and safety. The failure to remove such a violation after notice subjects the violator to the penalties set forth in the [*sic*] Administrative Code §26-248(d)(3), including a civil penalty of \$150 per day from the date that such removal has been substantially completed.

§32-03 Periodic Inspection of Exterior Walls and Appurtenances of Buildings.

(a) Definitions.

Critical examination. Critical examination means an examination conducted to review the exterior of a building and all parts thereof to determine whether the exterior walls and the appurtenances thereto are safe, unsafe, or safe with a repair and maintenance program and whether, in the judgment of a Registered Architect or Professional Engineer, they require remedial work.

Unsafe condition. Unsafe condition means a condition of a building wall, any appurtenances thereto or part thereof that is dangerous to persons or property and requires prompt remedial action. In addition, any condition which was reported as safe with a repair and maintenance program in an earlier report and which is not corrected at the time of the current inspection shall be reported as an unsafe condition.

Safe. Safe means a condition of a building wall, any appurtenances thereto or any part thereof not requiring repair or maintenance

Rules and Regulations

to sustain the structural integrity of the exterior of the building and that will not become unsafe during the next five years.

Safe with a repair and maintenance program. Safe with a repair and maintenance program means a condition of a building wall, any appurtenances thereto or any part thereof that is safe at the time of inspection, but requires repairs or maintenance during the next five years in order to prevent its deterioration during that five year period into an unsafe condition.

Standard reporting period. The standard reporting period is the time interval established by the Commissioner of Buildings for the filing of each successive report for each successive critical examination of every building subject to the requirements of Local Law 10 for the Year 1980 as amended by Local Law 11 for the Year 1998.

(b) *Critical examinations.*

(1) *Requirements.*

(i) In order to maintain a building's exterior walls and appurtenances in a safe condition in accordance with §27-129 of the Administrative Code, a critical examination of all parts of all exterior walls and any appurtenances thereto shall be conducted at periodic intervals, which are at least once every five years, of all existing buildings or buildings hereafter erected that are greater than six stories in height, except for those parts of any exterior wall which are less than twelve inches from the exterior wall of an adjacent building.

(ii) The second critical examination shall be conducted within two years after February 21, 1985 for all buildings covered by the first examination cycle. The initial critical examination for any building erected subsequent to February 21, 1982 shall be conducted in the fifth year following the erection or installation of any exterior walls and/or enclosures. Subsequent critical examinations shall be conducted within five years from the previous examination.

(iii) Regarding buildings in existence on March first, nineteen hundred ninety-eight, initial critical examinations of exterior walls or parts thereof and any appurtenances thereto which were not subject to such examinations under the provisions of paragraph (i) of subdivision (1) of section (b) of these rules in effect prior to March first, nineteen hundred ninety-eight, and which did not have a critical examination for which a report was filed prior to February twenty-first, nineteen hundred ninety-seven, shall be conducted prior to March first, two thousand.

(2) *Inspection procedures.*

(i) Before any exterior wall for any building is critically examined, the Registered Architect or Licensed Professional Engineer (hereinafter referred to as "professional") employed by the owner of the building shall carefully review the most recent report and any previous available reports. The Buildings Department will maintain a file of such reports submitted in conformance with §27-129, and furnish copies upon payment of fees set forth in §26-214.

(ii) Such examination shall be conducted and witnessed by or under the supervision of a professional retained by or on behalf of the owner of the building. It shall be done to the best of his/her knowledge and belief.

(iii) The professional shall determine methods employed in the examination, but he/she need not be physically present at the location where the examination is made. Under the professional's supervision, technicians, tradesmen, contractors, and

engineers-in-training may be delegated selected inspection tasks. These individuals need not be in his/her employ.

(iv) The methods used to examine the building shall permit a complete inspection of same. Except as herein required, the use of a scaffold or other observation platform is preferred, but the professional may use other methods of inspection as he/she deems appropriate. A physical examination from a scaffold or other observation platform is required for a representative sample of the exterior wall. The professional shall determine what constitutes a representative sample. The representative sample must include at least one physical examination along a path from grade to top of an exterior wall on a street front using at least one scaffold drop or other observation platform configuration.

(v) The known history of the building, the nature of the materials used and the conditions observed will dictate the extent of the critical examination.

The Registered Architect or Licensed Professional Engineer [sic] shall utilize a professional standard of care to detect splitting or fracturing of terra cotta on buildings, cracking of masonry and brick work in brick faced buildings, loosening of metal anchors and supports, water entry, movement of lintel angles, etc., and shall ascertain the cause of these and such other conditions detected. The professional shall order any special inspections and/or tests that may be required. The removal of portions of the façade in order to facilitate the performance of tests may require a permit from the Landmarks Preservation Commission.

(vi) During the course of the critical examination, photographs shall be taken and/or sketches made to properly document the location of all conditions observed that are either unsafe or safe with a repair and maintenance program.

(vii) Upon discovery of any unsafe condition, the professional shall immediately notify the Borough Commissioner and the owner of the building by letter or fax.

(3) *Report requirements.*

(i) The professional shall submit to the Commissioner and to the Owner of the building a written report as to the result of such examination, clearly documenting all conditions not classified as safe and stating that the inspection was performed and completed in accordance with the New York City Administrative Code.

(ii) The report shall include:

(A) The address, any a.k.a. addresses, the location from the nearest cross street, and Block and Lot numbers;

(B) The landmark status of the building;

(C) The name, mailing address and telephone number of the owner of the building, his agent or the person in charge, possession or control of the building;

(D) (a) The description of the building including number of stories, height, plan dimensions, Certificate of Occupancy number, if available, usage, and age and type of exterior wall construction;

(b) Brief history of any settlements, repairs, revisions to exterior enclosures, if available;

(E) A detailed description of the procedures used in making the critical examination;

(F) A detailed description of the extent and location of all physical examinations performed;

(G) A report of all conditions including significant deterioration and movement observed as well as a statement concerning the apparent water-tightness of the exterior surfaces, and the deleterious effect of exterior appurtenances, including exterior

Rules and Regulations

fixtures, flagpoles, signs, parapets, copings, guard rails, window frames (including hardware and lights), window guards, window air conditioners, flower boxes, etc. The report shall classify each such condition as safe, unsafe or safe with a repair and maintenance program;

(H) The causes of the reported conditions;

(I) The status of the exterior maintenance;

(J) Comparison of observed conditions with conditions observed during previous examinations, including status of the repairs or maintenance performed with respect to the prior conditions;

(K) Recommendations for repairs or maintenance, if appropriate, including the recommended time frame for same to be performed;

(L) Date of start and completion of the critical examination;

(M) The seal and signature of the professional under whose supervision the critical examination was performed shall be on the written report;

(N) If there are no unsafe conditions and no conditions that are safe with a repair and maintenance program, then the building shall be classified as safe;

(O) If there is at least one unsafe condition, then the building shall be classified as unsafe;

(P) If there is (are) a(ny) condition(s) that is (are) safe with a repair and maintenance program and there are no unsafe conditions, then the building shall be classified as safe with a repair and maintenance program;

(Q) The professional shall not file a report of the same condition that is safe with a repair and maintenance program for the same building for two consecutive filing periods. Unless the professional certifies to the correction of all conditions identified in the earlier report as requiring repair the building shall be classified as unsafe;

(R) Photographs and/or sketches documenting the location of any conditions that are either unsafe or safe with a repair and maintenance program;

(S) A statement by the professional indicating which repairs and/or maintenance require the obtaining of work permits prior to their commencement.

(4) *Report filing requirements.*

(i) Any building existing as of the date of the passage of Local Law 10 of 1980 shall file a report of the second examination of the building's exterior walls and appurtenances thereto no sooner than February 21, 1985 and no later than February 21, 1987, and thereafter no sooner or no later than February 21 of each fifth subsequent year.

(ii) Any building of which the erection or installation of any exterior wall or enclosures reached a height greater than six stories or for which a Temporary Certificate of Occupancy or Certificate of Occupancy was received prior to January 1, 1983 shall be required to file a report no later than February 21, 1987, and thereafter no later than February 21 of each fifth subsequent year.

(iii) Any other building of which the erection or installation of any exterior wall or enclosures reaches a height greater than six stories shall be required to file an initial report five years from the date when such height is obtained, and thereafter a report each subsequent fifth year; however, such initial report shall be filed no later than five years from the date a Temporary Certificate of Occupancy, or Certificate of Occupancy, whichever is sooner, is received.

However, if the date reached five years from such issuance falls between the standard reporting periods, the filing shall be

made during the first standard reporting period following the five-year date.

(iv) Persons or entities wishing to perform the critical examinations of and the report filing for the exterior walls referenced in Section (b) (1) (iii) of these rules in conjunction with the critical examinations of, and the report filing for the exterior walls otherwise scheduled for critical examinations and report filing from February twenty-first, two thousand until February twenty-first, two thousand two may perform such combined critical examinations and file such combined reports no earlier than February twenty-first, nineteen hundred ninety-nine and no later than March first, two thousand.

(v) Each written report shall be accompanied by a signed statement by the owner of the building acknowledging receipt of a copy of it and acknowledging awareness of the required repairs and/or maintenance, if any, and the time frame for same.

(vi) Each written report shall be submitted in original and in microfilm form to the appropriate Borough Office of the Department of Buildings. It shall be accompanied by an Exterior Periodic Inspection Report Form in triplicate, one copy of which may be retained by the applicant.

(5) *Unsafe conditions.*

(i) Upon the filing of the professional's report of an unsafe condition with the Department, the Owner of the building, his or her agent, or the person in charge of the building shall immediately commence such repairs or reinforcements and any other appropriate measures such as sidewalk sheds, fences, and/or safety netting as may be required to secure the safety of the public and to make the building's walls and/or appurtenances thereto conform to the provisions of the Building Code.

(ii) All unsafe conditions shall be corrected within 30 days from the filing of the critical examination report.

(iii) The professional shall inspect the premises and file a detailed amended report stating the condition of the building with the Borough office within two weeks after repairs to correct the unsafe condition have been completed.

(iv) The Commissioner may grant an extension of time of up to 90 days to complete the repairs required to remove an unsafe condition upon receipt and review of an initial extension application submitted by the professional, together with:

(A) Copy of original report with attachments;

(B) Notice that the premises have been made safe by means of a shed, fence or other appropriate measures;

(C) Copy of contract indicating scope of work to remedy unsafe conditions;

(D) Professional's estimate of length of time required for repairs;

(E) Notarized affidavit by owner of the building that work will be completed within stated time of professional's estimate.

(v) A further extension will be considered only upon receipt and review of a further extension application, together with notice of:

(A) Substantial completion of work but subject to an unforeseen delay (e.g., weather, labor strike), or

(B) Unforeseen circumstances (e.g., fire, building collapse), or

(C) Nature of hazard requires more than 90 days to remove (e.g., new wall to be built).

(6) *Conditions that are Safe with a Repair and Maintenance Program.*

Rules and Regulations

(i) The owner of the building is responsible for ensuring that the conditions described in the critical examination report as safe with a repair and maintenance program are repaired, and all actions recommended by the professional are completed within the required time frame, and are not left to deteriorate into unsafe conditions before the next critical examination.

(ii) The professional shall not file a report of the same condition that is safe with a repair and maintenance program for the same building for two consecutive filing periods.

(iii) A certification must be made by the professional attesting to the correction of all conditions identified in the earlier report as requiring repair.

(iv) The professional shall report conditions that were previously reported as safe with a repair and maintenance program as unsafe if not corrected at the time of the current inspection.

§32-04 Masonry Parapet Walls.

(a) *Definition. Parapet.* The term "parapet" shall mean the continuation of an exterior wall, fire wall, or party wall above the roof line. §27-232 Administrative Code.

(b) *Basic requirements.* Parapet walls of masonry constructed hereafter shall comply with the following requirements:

(1) They shall meet the requirements of Reference Standard §[sic]10-1, §10.4c of the Administrative Code.

(2) Structural members supporting parapet walls shall be designed to resist torsional stresses in addition to stresses due to bending, where loads are placed eccentrically.

(c) *Existing and new parapet walls.* Owners of those buildings which are provided with masonry parapet walls, except where such walls are located on buildings used exclusively for J-3 occupancy, shall have the parapet walls inspected annually by a competent person, such as a bricklayer, building superintendent, builder, architect, or engineer. Any wall found to be in an unsafe condition shall be removed promptly. Any parapet wall found to be out of plumb by a horizontal distance exceeding one-eighth of its height, shall be removed.

(d) *Replacement.* Parapet walls that are removed shall be replaced when the parapet wall is required by the provisions of §27-333 of the Administrative Code

***§32-05 Impact Resistant Stair and Elevator Enclosures** – In high rise buildings constructed pursuant to applications filed on or after July 1, 2006, stair and elevator enclosures serving occupancy group E spaces shall be constructed with impact resistant wall assemblies. A compliant wall assembly shall be substantially identical to, and shall provide an impact resistance equivalent to or exceeding, the performance of one of the following:

(a) **Stud wall.** Impact resistant construction boards shall satisfy the following requirements:

(1) Materials and assemblies shall comply with the following:

a. Materials: Impact resistant construction board sheathed on the impact face of the stair or elevator enclosure wall assembly shall be tested by a laboratory acceptable to the commissioner in accordance with the requirements of ASTM C1629, (*Standard Classification for Abuse-Resistance - Non-Decorated Gypsum Panel Products & Fiberglass-Reinforced Cement Panels*). The impact face shall be considered as the exterior of the stair or elevator enclosure, on the occupied side of the building, and shall be comprised of

two layers of construction boards. The construction board used as the base layer panel shall meet or exceed Impact Classification Level 2, as measured by the method described in ASTM C1629, and the face panel shall be a minimum $\frac{5}{8}$ inch gypsum construction board.

b. Assembly:

i. The wall assembly shall have a minimum two-hour fire resistance rating as measured by the method described in ASTM E119.

ii. The wall assembly shall meet or exceed Soft Body Impact Classification Level 2 (195 ft.-lbs) as measured by the method described in ASTM C1629.

(2) Installation:

a. Studs shall be minimum 3- $\frac{1}{2}$ inch depth metal studs, at least 33 mils thick (20 gauge).

b. Vertical studs shall be spaced at a maximum distance of 24 inches, on center.

c. Runners shall be securely attached at the floor and ceiling to structural element members in such a manner that provides lateral resistance in excess of the equivalent energy of Soft Body Impact Classification Level 2 of ASTM C1629. The installation of top and bottom runner tracks shall be subject to controlled inspection.

d. Construction boards shall be attached with No. 8 self-drilling bugle-head screws, 12 inches, on center maximum, with a minimum depth of $\frac{5}{8}$ inch penetration into the wall cavity. Screw attachments shall meet the requirements of ASTM C 1002, *Standard Specification for Steel Drill Screws for the Application of Gypsum Panel Products or Metal Plaster Bases*.

e. Joints between adjoining sheets of construction board shall be staggered from base layer with face panel layer.

(b) **Concrete and masonry walls.** Concrete or masonry walls shall satisfy the impact resistance requirements of this section provided that the enclosure walls are anchored to structural members that provide lateral support as required by the seismic provisions of RS 10. The assembly shall be rated for two-hour fire resistance, as measured by the method described in ASTM E119.

(c) **Other Wall Assemblies.** Wall assemblies not classified in (a) and (b) of this section shall comply with the following criteria:

(1) Impact face: Boards or materials constituting the impact face of the stair or elevator enclosure assembly shall be tested by a laboratory, acceptable to the commissioner, to provide an impact resistance equivalent to gypsum panel meeting Hard Body Impact Classification Level 3 resistance (150 ft.-lbs), as measured by ASTM C1629. When more than one layer of material is required to meet the impact resistance requirement, such layers shall be tested in tandem.

(2) Assembly:

Rules and Regulations

a. The wall assembly shall have a minimum two-hour fire resistance rating as measured by the method described in ASTM E119.

b. The wall assembly shall meet or exceed Soft Body Impact Classification Level 2 as measured by the method described in ASTM C1629.

(3) Installation: Wall assemblies shall be anchored to structural members in such manner that provides lateral resistance in excess of the equivalent energy of Soft Body Impact Classification Level 2 of ASTM C1629. The installation shall be subject to controlled inspection.

* *Editor's note: The following editions of the aforementioned referenced standards were current when Rule 32-05 was promulgated:*

ASTM C1629/C1629M - 05 Standard Classification for Abuse-Resistant Nondecorated Interior Gypsum Panel Products and Fiber-Reinforced Cement Panels

ASTM E119 - 05a Standard Test Methods for Fire Tests of Building Construction and Materials

ASTM C1002 - 04 Standard Specification for Steel Self-Piercing Tapping Screws for the Application of Gypsum Panel Products or Metal Plaster Bases to Wood Studs or Steel Studs

CHAPTER 33 EXEMPTIONS FROM CIVIL PENALTIES

§33-01 Exemption from Civil Penalties Imposed Pursuant to Administrative Code §26-212.1 (Work Performed Without a Permit).

(a) *Acceptance of waiver request.*

(1) If a violation is issued for work in progress after January 1, 1989, no claim of exemption from a civil penalty imposed pursuant to Administrative Code §26-212.1 will be considered.

(2) If a building owner claims exemption from such penalty on the grounds [*sic*] that all work was completed prior to January 1, 1989, such claim must be substantiated by an affidavit and supporting data.

(3) Partial exemption from such penalty may be claimed on the grounds [*sic*] that a building owner applies for a permit subsequent to the commencement of work for which such permit is required but prior to the completion of such work. Such owner may claim exemption from such penalty for that part of such work which is completed after such permit is issued. Such claim shall be filed at the time of application for such permit and shall be substantiated by an affidavit and supporting data.

(b) *Burden of proof.*

(1) The burden of proof is on the owner claiming such exemption.

(2) Supporting data shall consist of one or more of the following:

(i) dated receipt or cancelled check showing payment for work completed or materials delivered;

(ii) signed contract specifying dates by which work is to be completed;

(iii) affidavits from contractors or building supply warehouses concerning the subject illegal work;

(iv) written estimates proposed by contractors prior to commencement of the subject illegal work;

(v) dated photographs of the subject property;

(vi) proof of compliance with Workers' Compensation Law insurance requirements;

(vii) a survey of the subject property made prior to January 1, 1989; [*sic*]

(viii) any other documents deemed acceptable by the Commissioner.

(3) While no one of the above-listed documents will be deemed

dispositive, appropriate weight will be accorded to the application in its entirety, taking into account the particular facts and circumstances on a case-by-case basis.

(c) *Where to file.*

All claims for exemptions pursuant to these regulations must be submitted in writing to the Borough Superintendent of the appropriate borough office. The Borough Superintendent will review the claim and supporting documents and will advise the claimant of the decisions of the Department.

CHAPTER 34 ELECTRICAL CODE RULES

Subchapter A Phase-in of Electrical Code Technical Standards

§34-01 Phase-in of new standards for electrical work. In accordance with subdivision a of section 27-3024 of the administrative code, the commissioner hereby extends the date of application of the electrical code technical standards as hereinafter provided. During the period from January 1, 2003 through June 30, 2003 (the phase-in period) electrical work, including low voltage electrical work, may be performed either in accordance with the electrical code technical standards adopted pursuant to section 27-3024 of the administrative code or in accordance with the standards set forth in subchapter 2 of chapter 3 of title 27 of the administrative code as in effect prior to January 1, 2003, and the Bulletins, Code Committee Interpretations and rules issued pursuant to such subchapter (the old electrical code) at the option of the licensed master or special electrician or other authorized person performing the work. On and after July 1, 2003 all electrical work shall be performed in accordance with the electrical code technical standards.

§34-02 Review of applications for electrical permits and certificates of electrical inspection during the phase-in period.

An application for an electrical permit or certificate of electrical inspection, including an application for the legalization of unfiled work, filed during the phase-in period shall indicate whether the application is to be reviewed in accordance with the electrical code technical standards or the old electrical code. On and after July 1, 2003 all applications, including applications for the legalization of unfiled work shall be reviewed in accordance with the electrical code technical standards.

§34-03 Temporary certification to perform low voltage electrical work.

During the phase-in period business entities engaged in the business of installing, maintaining or repairing communication, signaling, alarm or data transmission systems may continue to perform low voltage electrical work in accordance with paragraph two of subdivision a of section 27-3017 of the administrative code pending the adoption of rules setting forth the requirements and procedure for the certification of low voltage installers.

§34-04 Definitions. For the purposes of this chapter, the following terms shall have the following meanings:

Electrical Code: The term "Electrical Code" means Chapter 3 of Title 27 of the Administrative Code of the City of New York. Such term shall include the Electrical Code Technical Standards.

Electrical Code Technical Standards: The term "Electrical Code Technical Standards" means the edition of the National Fire Protection Association NFPA 70 National Electrical Code ("NEC") currently adopted by New York City with such amendments as may be enacted by local law.

§34-05 Electrical advisory board. a. In accordance with section 27-3005(a)(7) of the Administrative Code, the Commissioner shall appoint a special board, to be

Rules and Regulations

known as the "electrical advisory board." The electrical advisory board shall provide advice regarding (i) the approval of the use of electrical appliances, devices, and materials not otherwise approved for use by the Electrical Code, (ii) the granting of approval to use wiring or appliances not otherwise allowed by the Electrical Code Technical Standards and (iii) the granting of approval for specified types of electrical installations. The members of the board shall be appointed annually and shall serve at the pleasure of the Commissioner. The number of members and their organizational affiliations shall be at the discretion of the Commissioner. The board shall have a Chair and Vice-Chair appointed annually by the Commissioner.

b. Electrical advisory board review shall be required in the following circumstances:

(1) Electrical Installations:

(a) Electrical advisory board review shall be required where service equipment totals 1000 Kilo-Volt Amperes ("KVA") or greater, or where any new alteration or addition to an electric service installation causes the altered installation to total 1000 KVA or greater, as further detailed below:

(A) A new installation of equipment totaling 1000 KVA or higher;

(B) Any change in an installation with a rating of 1000 KVA or higher, up to and including the second level overcurrent protection, unless it was fully described and approved as "future" on the original approved plan.

(C) Any addition to an existing installation which would bring the total to 1000 KVA or higher.

(D) A new installation or revised installation above 600 volts, irrespective of KVA rating.

(E) The addition of any equipment in a room, which would affect clearances around the equipment of a 1000 KVA installation.

(b) Electrical advisory board review shall be required where proposed electrical installations involve appliances and materials not covered by the Electrical Code Technical Standards.

(2) Electrical Equipment or Materials. Electrical advisory board review shall be required for manufactured wiring systems, low voltage lighting systems, painting equipment /spray booths, and electrical equipment not specifically addressed in the Electrical Code Technical Standards and any other electrical equipment not bearing the label of approval of an electrical testing laboratory acceptable to the Commissioner.

c. Filing Requirements for Electrical Advisory Board Review.

(1) Filing requirements for Electrical Installations 1000 KVA or Greater, or New or Revised Installations above 600 Volts

(a) A cover letter, payment as specified in (d) below, and 2 sets of complete drawings shall be filed at:

DEPARTMENT OF BUILDINGS

Bureau of Electrical Control

(address provided in the City's website, <http://www.nyc.gov>)

(b) Submission shall be made by a New York City Licensed Master or Special Electrician, a New York State Licensed Professional Engineer, or an individual with comparable qualifications from an outside jurisdiction.

(c) A filing fee of \$650.00 shall be paid for each submission, no part of which shall be refundable.

(d) Payment shall be made by a money order or corporate/business check, a bank check or a certified check, and shall be made payable to "Department of Buildings."

(e) Requirements for Plans and Drawings. All submissions for electrical advisory board review for service equipment totaling 1000 KVA or more or above 600 Volts shall include the following plans/drawings:

- One line diagram

- Plan view / service equipment room layout

- Physical details of switchboard & distribution panel equipment as per the following requirements:

(A) All drawings shall be clear, legible, and use standard notations. All drawings shall be folded to 8 1/2" x 11," except for equivalent electronic versions authorized by the Department.

(B) Installations that are not all new shall clearly mark what is new and what is existing. In addition, all new work shall be encircled by a 'bubble' or 'cloud' on the drawings.

(C) For residential installations, the calculations justifying a de-rating of the neutral shall be submitted.

(D) The plan view shall be drawn to scale, showing the point of service entrance into the building. If the building sets back from the property line, the underground service feeder shall be shown, including wire and raceway sizes.

(E) The arrangement of service equipment and its proximity to the point of service entrance shall be shown, complete with details of the equipment, and the manner in which service will be extended to the service equipment. If the switchboard is free standing, the clearance around the switchboard shall be shown.

(F) The location of the main switchboard and/or distribution panels in relation to the service equipment and how they are interconnected shall be shown.

(G) The location of the electric service room with respect to the surrounding areas shall be shown.

(H) The means of egress from the switchboard room and where it leads to shall be shown. The legal exit(s) to which egress door(s) lead shall also be shown.

(I) When there is more than one service location within a building, drawings shall contain a notation indicating that signs are posted at the entrance door of each switchboard room showing the location of all the other switchboard rooms. The location and wording of the signs shall be specified.

(J) If the existing service equipment and/or point of service entrance is to be discontinued, the drawings shall so state.

(K) If existing service equipment is to remain in conjunction with new service equipment and is to be supplied by the same service entrance, the drawing shall indicate the make and size of the existing service equipment, the size and location of the ground strap, and the type and size of the fuses in the existing equipment.

(L) The drawing shall show grouping of service equipment at the point of service entrance.

(M) The drawing shall show ventilation of the room when the service equipment totals 2000 KVA or larger (this may be in the form of a note on the drawing).

(N) The drawing shall show the available short circuit current at the point of service entrance and at the point of change in the interrupting rating of the overcurrent protection. Where used, series ratings shall be indicated.

(O) A statement confirming that all fuses and/or circuit breakers have been coordinated for selective short circuit overcurrent protection shall be on the drawing.

(P) A one line diagram shall be submitted indicating the service equipment and the distribution equipment up to the 2nd level overcurrent protection, showing all

Rules and Regulations

overcurrent devices with their ampere rating, make and type, interrupting current ratings and bus and wire sizes. Frame and trip sizes for circuit breakers shall be indicated.

(Q) Drawings shall indicate that transformers are properly grounded. Service and distribution equipment proposed for future installation shall be marked on the drawings as "future."

(R) All voltages shall be clearly shown on the drawings, which shall include voltages pertaining to all of the equipment overcurrent protection up to and including the second level protection.

(S) Drawings shall note that cables used in a trough shall be grouped A, B, C, & N respectively. Where troughs are used for taps, the copper detail or a description of the tap shall be noted, confirming that multiset conductors are tapped correctly.

(T) The physical size of the vertical bus in the distribution panels (second level equipment) shall be shown. The overcurrent devices, bus, barriers, and gutter space layout shall be shown. Layouts of previously approved panels (to be so noted on plans) need not be submitted.

(U) When a generator (or other non-utility source) is part of a 1000 KVA submission and the generator itself is rated below 1000 KVA, a one line diagram shall be submitted showing how the generator is connected to the normal service. The drawings shall include the grounding of the generator frame and neutral bonding if needed (four pole transfer device). If the generator is rated 1000 KVA or larger, a room layout shall be submitted along with a one line diagram, and physical drawings shall show a section view of the emergency switchboard. Also, the Advisory Board calendar number for the normal service shall be specified.

(V) Physical detail drawings for switchboard equipment shall show front and section views and shall be drawn by the switchboard manufacturer. Elevation detail shall show access to the bus connections, the size and location of the main bonding jumper (ground strap), the disconnect link in the neutral, all the barriers and how load cables leave the cabinet. Side section views shall clarify bus details.

(W) Details of gutter space, lug covers and dimensions of lugs and enclosures up to the 2nd level distribution equipment shall be shown.

(2) Filing requirements for electrical advisory board review of Appliances, Devices, and Materials Not Covered by the Electrical Code Technical Standards.

(a) A cover letter together with appropriate drawings, sketches, charts, and/or cut sheets shall be filed at:

DEPARTMENT OF BUILDINGS

Bureau of Electrical Control

(address provided in the City's website, <http://www.nyc.gov>)

(b) A filing fee of \$350.00 shall be paid for each submission made where an electrical violation was issued due to failure to obtain prior Electrical Advisory Board review and approval, no part of which shall be refundable.

(c) Payment shall be made by a money order or a corporate/business check, a bank check or a certified check, and shall be made payable to "Department of Buildings."

(3) Filing requirements for electrical advisory board review of Electrical Equipment and Materials.

(a) The submission, including a cover letter and check, shall be filed at the following location only:

DEPARTMENT OF BUILDINGS

Bureau of Electrical Control Advisory Board
(address provided in the City's website, <http://www.nyc.gov>)

(b) A filing fee of \$200.00 shall be paid for each submission, no part of which shall be returned.

(c) Payment shall be made by either money order, bank check, certified check or corporate/business check. The payment instrument shall be made payable to "Department of Buildings."

(d) The submission shall contain the following:

(A) A cover letter indicating the following:

(i) Type/model numbers of material/equipment being submitted for approval.

(ii) Items included in support of the submittal.

(iii) Explanatory information/comments, if applicable.

(B) A completed & notarized application for review.

(C) Two (2) brochures, or catalog data sheets, and a set of unmounted photographs or photographs transmitted electronically as authorized by the Department.

(D) A complete test report that includes a conclusion sheet from a laboratory acceptable to the Commissioner.

(E) Equipment samples only when requested by the Electrical Advisory Board.

d. Compliance with the Energy Conservation Construction Code of New York State ("Energy Code"). All submissions made to the Electrical Advisory Board shall comply with the requirements of the Energy Code where applicable.

§34-06 Electrical Code Revision and Interpretation Committee. In accordance with section 27-3005(a)(7) of the Administrative Code, the Commissioner shall appoint a special committee to be known as the "electrical code revision and interpretation committee". The committee may propose to the commissioner local amendments to the NEC and shall, upon request, provide interpretations and clarifications of the Electrical Code Technical Standards. The number of members and their organizational affiliations shall be at the discretion of the Commissioner. The members of the committee shall be appointed annually and shall serve at the pleasure of the Commissioner. The Committee shall have a Chair, Vice-Chair and Secretary appointed annually by the Commissioner. All proposed local amendments to the NEC adopted or considered for adoption by the city shall be submitted to the committee for review.

§34-07 Electrical Code Advisory Committee. In accordance with section 27-3005(a)(7) of the Administrative Code the Commissioner shall appoint a special committee to be known as the "electrical code advisory committee". The committee shall advise the Commissioner regarding the approval of local amendments to the NEC proposed by the Electrical Code Revision and Interpretation Committee and the implementation of such amendments, and shall act as a conduit between the Department and the electrical industry regarding such proposed amendments and their implementation. The members of the committee shall be appointed annually and shall serve at the pleasure of the Commissioner. The number of members and their organizational affiliations shall be at the discretion of the Commissioner. The Committee shall have a Chair, Vice-Chair and Secretary appointed annually by the Commissioner. The Commissioner shall submit all local amendments to the edition of the National Fire Protection Association NFPA 70 NEC currently adopted or being considered for adoption by the city to the committee for review.

Rules and Regulations

CHAPTER 35 ELECTRICAL INSPECTION

§35-01 Designation of Private Agencies to Perform Electrical Inspections in the City of New York.

(a) *Grounds for certification and renewal of certification.* The commissioner may grant and each January thereafter renew certification of private electrical inspection agencies, provided:

(1) the agency applying for certification certifies in writing that each of the inspectors it shall employ to conduct the inspections permitted by §27-3005(2)(b) of the Administrative Code shall possess five years experience as an electrician or inspector of electrical installation; or three years of experience as an electrician or inspector of electrical installation plus two years of education at an accredited college technical school in a program emphasizing courses in electrical installations or education toward a baccalaureate degree in Electrical Engineering or Engineering Technology with an emphasis on electrical installation or repair. Two of the requisite years of working experience as an electrician or inspector of electrical installation shall be experience in the installation of lighting, heating and power. Experience and education must be acceptable to the Department of Buildings and is subject to the Commissioner's Review and approval; and

(2) the agency possesses

(i) a general liability insurance policy in excess of \$5 million, and

(ii) worker's compensation insurance for its employees and submits copies of the Insurance Certificates to the Commissioner; and

(3) the agency furnishes the names of its inspectors and documentation supporting the experience required by §35-01(a)(1) hereof, and thereafter promptly advises the commissioner of any changes in personnel affecting the inspection permitted; and

(4) the agency prohibits its inspectors and other employees from accepting any gratuities or other benefit for work performed pursuant to these regulations and §27-3005(2)(b) of the Administrative Code; and

(5) the agency does not conduct an inspection pursuant to §27-3005(2)(b) of the Administrative Code of any work performed by any of its own officers, employees, or any other persons associated with the agency; and

(6) the agency has a legal place of business within the City of New York (P.O. Box not acceptable).

(b) *Right to deny or revoke certification.*

(1) The commissioner or his designee may deny or revoke certification where investigation reveals any of the following:

(i) the agency has failed to comply with any of the provisions enumerated in §35-01(a) of these rules and regulations;

(ii) the agency has knowingly made false or misleading statements, or knowingly falsified or allowed to be falsified any certificate, form, signed statement, application, or report filed with the department, or failed to file a report required by law or the department or willfully impeded or obstructed such filing, or induced another person to do so;

(iii) the agency engages in any other conduct evidencing a willful or grossly negligent failure to comply with provisions of state or local law, or rules or regulations promulgated pursuant to statutory authority; or

(iv) the agency engages in any other conduct evidencing a departure from the standard or good character applicable to the trade of licensed electrician.

(2) Where the commissioner or his designee, in his or her discretion, deems the certification of the agency shall be

revoked, the agency shall be entitled to a hearing before the Office of Administrative Trials and Hearings as provided by rules promulgated by the department.

(3) Where the commissioner or his designee, in his or her discretion, deems that continued certification of the agency would be likely to create a condition of imminent peril to public safety, the revocation determination shall be effective immediately. In such an instance, the agency shall be entitled to a hearing pursuant to §35-01(b)(2) of the rules at the next available scheduled hearing session before the Office of Administrative Trials and Hearings.

(c) *Contractual obligation.*

(1) A contractual agreement between the agency and the City of New York is required in order for the agency to perform electrical inspections for the City of New York.

(2) Certification by the Commissioner is a prerequisite for participation in the contracting process.

§35-02 Payment of Fees for Certificates of Electrical Inspection.

(a) All applications for a certificate of electrical inspection for electrical work filed with the Department of Buildings shall specify a completion date for such work. No certificates of electrical inspection, other than temporary certificates for electrical service, shall be issued, unless and until the required total application fee or fees therefore [sic] shall have been paid to the commissioner.

(b) The fees required to be paid pursuant to § [sic] 27-3018(b) of the Administrative Code shall be paid as follows:

(1) The filing fee set forth in § [sic] 27-3018 subdivision (b) of the Administrative Code shall be paid upon the filing of the application for a certificate of electrical inspection.

(2) (i) The licensee shall schedule an inspection within thirty (30) days after the completion date specified on the application in accordance with procedures established by the Department. The remainder of the total fee, based upon the work listed on the application, shall be due and payable upon completion of the scheduled inspection by the Department. Upon completion of the inspection and the Department's determination that the work performed is complete and in compliance with the applicable provisions of the Electrical Code and upon the Department's having received full payment of applicable fees including any additional fee payable under paragraph (4) of this subdivision, a certificate of electrical inspection shall be issued to the licensee.

(ii) If the licensee fails to schedule an inspection in accordance

Rules and Regulations

This page is intended to be left blank.

Rules and Regulations

with Department's procedures within thirty days after the completion date specified on the application for a certificate of electrical inspection or such date as extended by the Department, or cancels a scheduled inspection appointment with less than forty-eight (48) hours notice or cancels a scheduled inspection more than forty-eight (48) hours prior to the inspection without scheduling an alternative date in accordance with Department procedures, or fails to provide access for the scheduled inspection, or if upon inspection it is determined by the Department that the work is not complete, or the scope of the work exceeds the scope of work indicated on the application, or the work is not in compliance with the Electrical Code, the remainder of the total fee shall be due and payable immediately.

(3) Where the remainder of the total fee is due and payable immediately as provided in paragraph (2)(ii) above, the licensee shall continue to be required to schedule an inspection(s) in the same manner as the initial inspection until the Department determines that the work performed conforms with the scope of the work indicated on the application and is in compliance with the applicable provisions of the Electrical Code. Upon such a determination and upon the Department's having received full payment of applicable fees including any additional fee payable under paragraph (4) of this subdivision, a certificate of electrical inspection shall be issued to the licensee.

(4) Any additional fee, based on amendments to the original application that include additional work, must be paid prior to the issuance of a certificate of electrical inspection.

CHAPTER 36 ELECTRICAL CONTRACTORS

§ 36-01 Evaluation of Educational Experience of Applicants for Electrical Contractor Licenses.

(a) *Experience.* Any applicant for an electrical contractor's license must have experience in the installation, alteration and repair of wiring and appliances for electrical, [sic] light, heat and power in or on buildings as set forth in New York City Administrative Code §27-3010. In evaluating this experience, credit may be given for the educational experience of applicants who have attended courses in a recognized vocational, industrial or trade school in electrical wiring, installation and design, or applied electricity.

(b) Description of course credit in recognized vocational, industrial or trade schools in electrical wiring, installation and design, or applied electricity.

(1) A recognized vocational, industrial or trade school in electrical wiring, installation and design, or applied electricity, is one offering a comprehensive curriculum of classes and practical laboratories taught in a logical progression to complete a specific course of study in electricity, as set forth in the description of the instructional program in residential, industrial and commercial electricity contained in the New York State Education Department guidelines for trade and industrial education, or the equivalent as determined by the Commissioner of Buildings upon the recommendation of the New York City Electrical License Board.

(2) A curriculum year of credit shall be no less than 200 classroom hours comprised of 20 percent lecture hours and 80 percent practical laboratory hours, or the equivalent as determined by the Commissioner of Buildings upon the recommendation of the New York City Electrical License Board.

§ 36-02 Impact of Periods of Unemployment upon Applications for Electrician's Licenses.

(a) *Applicability.* Pursuant to New York City Administrative Code §27-3010, any applicant for a master or special electrician's license shall have had, immediately preceding his or her application, at least seven and one-half (7½) years of experience in the installation, alteration and repair of wiring and appliances for electric light, heat and power in or on buildings. In evaluating this experience, the Department recognizes that periods of unemployment may make continuous employment for the seven and one-half (7½) years preceding his or her application impossible. Thus, in evaluating whether a master or special electrician's license applicant has sufficient work experience, the Department may exclude periods of unemployment when considering whether work experience immediately preceded the application date, as set forth in this rule.

(b) In accordance with the above, the Commissioner may grant a master or special electrician's license application where the applicant's work experience has occurred within the ten years immediately preceding the application date, if: (i) the applicant has had at least seven and one-half years of such experience, and during such time, a minimum of seventy-five hundred (7500) hours or the equivalent experience in the legal installation, alteration and repair of wiring and appliances for electric light, heat and power in or on buildings in such ten years immediately preceding the application date; and (ii) during the two calendar years immediately preceding the application date, the applicant has been employed in the legal installation, alteration and repair of wiring and appliances for electric light, heat and power in or on buildings for at least a total of twelve months.

(c) Subdivision (b) shall not apply to electrician's license applicants whose work experience includes electrical work that was not supervised by a licensed electrician, or that was otherwise illegal.

Nothing in this rule shall affect how credit for the seven and one-half (7½) years of work experience is computed pursuant to New York City Administrative Code §27-3010 (a)-(e).

CHAPTER 37 REFERENCE STANDARDS

§37-01 Rules of Procedure for Amending, Revising or Promulgating Reference Standards.

(a) **General.** Pursuant to Administrative Code §27-131.1, the Commissioner is empowered to issue or amend the building code reference standards, acting in consultation with the fire commissioner on all issues relating to fire safety. This rule establishes the procedure to be followed.

(b) Definitions.

(1) "Advisory Committee" shall mean the committee appointed by the Commissioner, consisting of members of the Department, the fire department, a registered architect, a professional engineer and representatives of the building and construction industry. The advisory committee shall be chaired by the Deputy Commissioner for Technical Affairs.

(2) "Task Force" shall mean a committee appointed by the mayor or the Commissioner to investigate a particular matter. Such committee shall include members of the public. The fire department shall be a member of any task force charged with investigating matters involving fire safety.

(c) **Initial Consultation with the fire department.** Where it is proposed to revise or amend reference standards 3-1, 3-2, 4-6, 5, 7-3, 8-1, 10-8, 10-9, 13-1, 13-2, 13-3, 13-6, 13-16,

Rules and Regulations

14-11, 14-12, 14-13, 17, 18-1 and 19-1 and any other reference standard pertinent to fire safety, the fire department shall participate in preliminary meetings on proposed changes to these reference standards.

(d) Review by advisory committee. (1) Prior to publishing a proposed reference standard or amendment thereto, said proposal shall be distributed to the advisory committee for review and comment. In lieu of a review by the advisory committee, the Commissioner may direct a task force to review and comment on a proposed reference standard when said reference standard relates to the concerns of the task force.

(2) The advisory committee or task force shall review all proposed reference standards and shall timely comment on each draft submitted. The Department shall forward the advisory committee or task force a [sic] final draft of the reference standards relevant to fire safety to the fire department for review and comment.

(e) Public notice and hearing. (1) Upon receiving the comments of the advisory committee or task force, the full text of the proposed reference standard shall be published in the City Record at least twenty (20) days prior to the date set for a public hearing.

(2) Such published notice shall include a draft statement of the basis and purpose of the proposed reference standard, the time and place of public hearing and the final date for receipt of written comments.

(3) No proposed reference standard is to be published in the City Record unless comments required pursuant to §37-01(d)(2) have been received from the fire department or at least thirty (30) calendar days have elapsed from the submission of the final draft to the fire department, whichever is sooner.

(4) The final date for receipt of written comments regarding the proposed reference standard shall be five (5) calendar days after the public hearing.

(5) In the event substantive changes which may affect fire safety are made to the reference standard after the public hearing, the fire department shall review such draft and have ten (10) calendar days to comment.

(f) Final publication. (1) A reference standard shall become effective upon publication in the City Record after the close of the applicable comment period set forth in §37-01(e)(4) or (5), whichever is later.

(2) The reference standard as adopted shall be published in the next supplement to the compilation of "Building Code Reference Standards" and included as part of the Administrative Code.

CHAPTER 38 VENTILATION

§38-01 Ventilation of Garage Spaces Below Grade.

(a) Wherever the floor of a garage designed for the live storage of five (5) or more motor vehicles is more than two (2) feet below curb, ventilation shall be provided as required by the provisions of subdivision a of §C26-267.0 of the Administrative Code.[sic]

(b) Air exhaust ducts shall terminate above the roof of the garage or the roof of the building or shall terminate at least ten (10) feet above the curb in an exterior wall adjoining a legal street, yard or court. No air exhaust duct shall terminate within fifteen (15) feet of a window in another building, nor within fifteen (15) feet of a window in the residence portion of the

same building.

(c) The ventilating system shall comply with Reference Standard 13.

CHAPTER 39 COOLING TOWERS AND EVAPORATIVE CONDENSERS

§39-01 Cooling Towers and Evaporative Condensers.

(a) Before any cooling tower or evaporative condenser is erected, a permit shall be obtained.

(b) Plans of the cooling tower or evaporative condenser shall be filed with the application for a permit, showing details of construction, such as materials, dimensions, thickness of metal, weight of tower or condenser and details of all structural members and supports, including details of the method of support on the structure below and within such structure and any required anchorage.

(c) Stresses permitted in structural members and connections shall not exceed the limitations of the Administrative Code.

(d) The minimum thickness of any structural steel members shall be one-quarter inch, including all bracing and secondary members.

(e) The location of the cooling towers and evaporative condensers shall comply with the pertinent provisions of the Zoning Resolution.

(f) All materials used in cooling towers, except the drip bars, shall be constructed of incombustible material. The supports of drip bars are required to be of incombustible material.

CHAPTER 40 INSTALLATION AND MAINTENANCE OF GAS-FUELED WATER AND SPACE HEATERS IN ALL PORTIONS OF DWELLINGS USED OR OCCUPIED FOR LIVING PURPOSES

Subchapter

- A *Scope*
- B *Departmental Procedure*
- C *Where Heaters May be Used*
- D *Installation of Gas-Fueled Heaters*

Subchapter A *Scope*

§40-01 Installation and Maintenance of Gas-Fueled Water and Space Heaters in all Portions of Dwellings Used or Occupied for Living Purposes.

These rules shall govern the installation and maintenance of gas-fueled space and water heaters in the residence portions of multiple dwellings in the City of New York, including but not limited to the installation of such devices in multiple dwellings which are installed in lieu of centrally supplied heat and hot water under the provisions of §27-2028 and §27-2032 of the Administrative Code and in one and two family residences not heated by a central heating system.

Subchapter B *Departmental Procedure*

§40-11 Applications and Plans.

(a) Before commencing the installation of a gas-fueled space or water heater in a dwelling an application, as specified below must be filed in the borough office of the Department of Buildings where the installation is to be made, giving the

Rules and Regulations

address of the dwelling and all pertinent information required on the forms.

(b) Applications shall be accepted only where gas appliances will be connected to flues in existing brick chimneys, and where no other venting or other work is required to be done. They shall not be accepted for installation of gas-fueled heaters in sleeping rooms. Applications shall clearly state the type of appliance to be installed, the floors, apartments and rooms in which they are to be placed, including the number of rooms in the apartment and the occupancy of each room, whether sleeping room or otherwise. They shall describe the condition of the chimney flue to be used and state whether the draft is satisfactory. If a gas meter is to be installed its location shall be given.

(c) Where vent pipes are to be installed, or other work done in connection with the installation of gas-fueled heaters, an application shall be filed. It shall indicate the type of each such device, the floor on which, and the apartment and the occupancy of the room in which such appliance is to be installed, the material and dimensions of the vent pipe or flue, and the dimensions of the court or yard to which the exhaust vent will be carried. If a gas meter is to be installed, its location shall be shown. No plumbing specification sheet need be filed with such application.

(d) Application for permits to install gas-fueled space and water heaters may be made separately or together on one application but each such application shall indicate that all apartments in the building will be provided with gas-fueled space and/or water heaters as the case may be. The location, type, make, and capacity of all such appliances previously installed or to be installed in a building shall be specified. If any of the appliances have been installed in multiple dwellings prior to December 9, 1955, which the owner desires to maintain, the necessary work to make them comply with these rules should be indicated.

(e) An application may be filed by the owner of the premises, or his architect, engineer, contractor, plumber or other agent. If the application is not filed by the owner, an [sic] owner's authorization form also shall be filed.

§40-12 Examination and Approval of Applications.

(a) Applications, when filed, shall be processed in the usual manner and forwarded to the inspectors of plumbing.

(b) Applications calling for the installation of gas fueled space and water heaters shall be expedited and may be taken out of turn, except that they shall be processed in the order in which they were received. They shall be examined for compliance with these rules and all other laws and regulations applicable to such installations. If any chimney or metal stack is to be installed, examiners shall check such construction for compliance with subchapter 15 of Chapter 1 of Title 27 of the Administrative Code (Building Code). They shall require that the foundation shall be carried not less than four feet below the surface of the ground, and that the soil on which it is built to be not overloaded. They shall require that new chimneys be strapped to the existing walls.

(c) Only applications calling for the installation of gas-fueled space or water heaters, approved by the Department of Buildings, specifying the make and model shall be approved. All such gas appliances shall be of types approved also by the American Gas Association. However, where an owner desires to continue to use any gas appliance installed in a

multiple dwelling prior to December 9, 1955, clearly shows on the plan the data required by §40-11(f) and prominently marks the appliances that have not been approved by the Department of Health, the application may be conditionally approved pending the approval of the appliances by the Department of Health.

§40-13 Commencement of Work.

(a) It shall be unlawful to commence any construction for which an application has been filed until a permit for the proposed work has been issued by the borough superintendent, and it shall be unlawful to commence the installation of piping of any gas appliance until a registered plumber has filed a signed statement with the borough superintendent containing the address of said plumber and stating that he is duly authorized to proceed with the work.

(b) The plumber shall notify in writing the borough superintendent of the Department of Buildings of the borough in which any gas-fueled space or water heater is to be installed, [sic] when such work is to begin and when it will be ready for operation and inspection.

§40-14 Inspection of Gas-Fueled Space and Water Heaters.

(a) Where an application has been filed it shall be the responsibility of the inspectors of plumbing to see that gas-fueled space and water heaters are installed in dwellings, apartments and rooms where such heaters are permitted to be installed in lieu of central heat or supply of hot water. They shall see to it that the appliances are of types approved by the Department of Buildings and the American Gas Association, and are installed in compliance with these rules.

(b) An application covering the installation of these appliances in dwellings shall be forwarded directly to the plumbing inspectors when approved as a permit. The installation of such appliances including Type B and other gas vents, but not chimneys, shall be inspected by inspectors of plumbing. If an application does not call for construction of a masonry or metal chimney, it shall be reported as completed, by the plumbing inspector, provided the work was satisfactory with a note on his report "no structural work."

(c) If the application calls for the erection of a masonry or metal chimney, it shall be forwarded by the plumbing inspector to the construction inspector as soon as the plumbing inspector has found the installation of these gas appliances and vent connections satisfactory. The construction inspector shall report such an application completed if the construction of the chimney has been satisfactorily performed.

§40-15 Issuing Approvals.

(a) A gas-fueled space or water heater installed after December 18, 1957, and a gas-fueled space heater installed prior to that date, in the residence portion of a multiple dwelling and installed after October 1, 1964, in one and two family dwellings, shall be approved by the Department of Buildings only if it is of a type approved by the Department of Buildings and the American Gas Association, and if it has been installed in compliance with these rules. A gas-fueled water heater installed in a multiple dwelling prior to December 18, 1957, and in a one or two family dwelling prior to October 1, 1964 shall be approved by this department only after it has been made to comply with all the requirements of these rules. The certification of approval of type of appliance by the Department of Buildings of such water heaters shall be

Rules and Regulations

attached to the application.

(b) An application which has been filed to cover the installation of only gas-fueled space heaters or only gas-fueled water heaters shall be reported as being satisfactorily completed only if all apartments in the building have been provided with either space or water heaters as the particular application specified. If an application calls for the installation of both space heaters and water heaters it shall be reported as being satisfactorily completed only if all apartments in the building have been provided with both space heaters and water heaters. Nor shall any application be reported as being satisfactorily completed unless all new appliances have been installed in compliance with these rules and all existing appliances have been made to conform with them.

(c) When the plumbing section signs off, as satisfactorily completed, an application which provides for the installation of gas-fueled space heaters in all apartments of a multiple dwelling, including the apartments where gas-fueled space heaters may have been installed prior to December 18, 1957, they shall make a list of such premises and send a copy of the list to the Department of Housing Preservation and Development. Where water heaters also have been satisfactorily installed, that fact shall be noted on the list. The list shall contain the premises and the application number under which the appliances have been installed, and shall be forwarded weekly.

Subchapter C *Where Heaters May be Used*

§40-21 Substitution for Central Heating or Hot Water Supply. Gas-fueled space or water heaters may be used in lieu of centrally supplied heat or hot water only in an apartment in a dwelling which complies with all the following requirements:

- (a) The apartment shall consist of two or more living rooms.
- (b) The apartment shall consist entirely of rooms used in Class A occupancy, or in one or two family dwellings.
- (c) The apartment shall not be, in whole or in part, arranged, designed or intended to be used for single room occupancy.
- (d) The apartment shall not have been formed, in whole or in part, as a result of work done to increase the number of apartments of a converted dwelling or a tenement under an application or plan filed with the department on or after December 9, 1955.
- (e) The apartment shall not be located in a building which has been vacant under conditions and for periods which render it subject to the provisions of §27-2089 of the Administrative Code.
- (f) The apartment shall not have been converted or altered under plans filed with the department on or after December 9, 1955 so as to cause any existing or newly created portion of a Class A or Class B converted dwelling not previously constituting an apartment consisting of rooms used for Class A occupancy to become such an apartment.
- (g) The apartment shall not be a part of a Class A or Class B multiple dwelling which is or was converted to such dwelling from a single family or two-family dwelling under an application or plan filed with the department on or after December 9, 1955.
- (h) The apartment shall not be in a tenement which, after being used or occupied as other than a tenement, is or was reconverted to a tenement under any application or plan filed with the department on or after December 9, 1955.

(i) In accordance with Building Code Reference Standard P107.26.

Subchapter D *Installation of Gas-Fueled Heaters*

§40-31 Required Approvals of Appliances. Gas-fueled space and water heaters, installed after December 18, 1957, in apartments in multiple dwellings, in lieu of centrally supplied heat or hot water where such centrally supplied heat or hot water supply is required by the Multiple Dwelling Law,^[sic] and in one and two family dwellings installed after October 1, 1964 shall be of types approved by the Department of Buildings and the American Gas Association.

§40-32 Prohibited Types of Water Heaters. On and after December 18, 1957, it shall be unlawful to install in any apartment in any multiple dwelling, and after October 1, 1964 in a one or two family dwelling a gas-fueled water heater, so designed and arranged that it heats water in pipe coils placed at a distance from the hot water storage tank.

§40-33 Number and Capacity of Gas-Fueled Heaters.

(a) Where gas-fueled heaters are permitted to be installed in lieu of the required centrally supplied heat, each "living room," as such term is defined in subdivision 18 of §4 of the Multiple Dwelling Law, shall be heated by a heater placed in such room or in an adjoining room which connects with it except that a room whose exterior walls are exposed only on a fully enclosed inner court may be heated by a heater located one room removed from such room. For this purpose, an inner court shall be considered fully enclosed even though some of the enclosure walls are located on an adjoining lot. The aggregate input capacity of the heater or heaters installed in any apartment shall not be less than the number of living room times ten thousand (10,000) British thermal units per hour.

(b) Notwithstanding the provisions of subdivision (a) of this section, there shall be installed and continuously maintained by the owner in each apartment gas-fueled heaters in such numbers and at such locations as shall be sufficient to heat such apartment to the minimum temperature which would be required to be maintained therein by the owner under the provisions of the Health Code of the city relating to the heating of buildings, if such owner were required to furnish centrally supplied heat in such apartment.

(c) The requirements of subdivision (a) and (b) of this section are not applicable when an apartment in a multiple dwelling is heated by gas-fueled space heater or heaters which were installed by a tenant prior to December 18, 1957, and in a one or two family dwelling prior to October 1, 1964 and owned by such tenant or successor tenant.

§40-34 Capacity of Water Heaters. Gas-fueled water heaters shall be automatic storage types having a capacity of not less than twenty gallons and shall, in any event, be adequate to provide a supply of hot water as defined in §27-2031 and §27-2034 of the Housing Maintenance Code, and §131.042 of the Health Code.

§40-35 Shut-Off Devices. Each gas-fueled space or water heater installed in an apartment in a dwelling shall be equipped with an effective device which will automatically shut off the gas supply to such heater in the event that its pilot light or other constantly burning flame is extinguished, or in the event of an interruption of the gas supply to such heater. Such

Rules and Regulations

automatic gas shut-off device shall be of type which, after it has shut off the supply of gas to a heater, will not permit such heater to be relighted unless such shut off device is first reset manually.

§40-36 Gas Piping.

(a) The sizes of gas piping shall be such as to give an adequate volumetric flow of gas to all appliances. The minimum diameter of gas piping shall be three-quarters of an inch (3/4") except that a branch supplying only one appliance may be one-half inch (1/2") diameter.

(b) Each gas-fueled space and water heater shall be rigidly connected to the gas piping supplying gas to the apartment.

§40-37 Appliances in Sleeping Rooms.

(a) Gas-fueled water heaters shall not be installed in a room occupied for sleeping purposes, in bathrooms, or in any occupied room normally kept closed.

(b) It shall be unlawful to install a gas-fueled space heater in a room occupied for sleeping purposes except when the space heater is so designed, installed and operated for it:

(1) Obtains combustion air directly from the outside of the building or through a duct leading to the outside.

(2) It vents directly to space outside of the building other than an inner court, or is connected through a flue or outlet pipe with an outside chimney which conforms with the requirements of Subchapter 15 of Chapter 1 of Title 27 of the Administrative Code (Building Code).

A flue in an existing brick chimney may be used if it is in good condition and tests show that it will provide adequate draft.

§40-38 Clearances from Combustible Materials.

(a) Space heaters and water heaters approved by the American Gas Association Laboratories, shall have clearance from combustible materials in accordance with the terms of their approval.

(b) Gas-fueled space and water heaters shall be installed also in conformity with any applicable requirements of specification Z21-30 of 1954 of the American Standards Association, except where these rules otherwise provide.

(c) Vent connectors and vent and outlet pipes shall be installed so as to provide a minimum clearance of three inches on all sides from combustible material. Vent and outlet pipes shall not pass through a floor. Where a vent or outlet pipe passes through a partition or roof constructed wholly or in part of combustible material, a ventilated metal thimble not less than six inches larger in diameter than the pipe shall be provided. Any material used to fill the space between the vent pipe and the thimble shall be incombustible.

§40-39 Venting of Gas Appliances. (a) Definitions.

Flue, vent or outlet pipe. A "flue, vent or outlet pipe" is a conduit or passageway, vertical or nearly so, for conveying flue gases to the outer air.

Vent connector. A "vent connector" is a pipe connecting an appliance with the flue, vent, outlet pipe or chimney.

(b) Every vent or outlet pipe serving a gas space or water heater shall be provided with a draft hood of a type approved by the American Gas Association, Inc., laboratories of the Underwriters' Laboratories, Inc., as conforming to accepted standards, unless the heater has an approved built-in draft hood, or has been approved by the American Gas Association without a draft hood. The draft hood shall be installed at the flue collar or as near to the appliance as possible and in the

position for which it was designed, with reference to horizontal and vertical planes. The relief opening of the draft hood shall not be obstructed. A suitable cap shall be provided at top of vent pipes.

(c) Each gas-fueled space or water heater installed in an apartment in lieu of the required centrally supplied heat and hot water supply, respectively, shall be connected to a chimney flue, outlet pipe, or type B vent, complying with the requirements of subdivision (h) of this section, which shall be carried four feet above a flat roof and two feet above the highest part of a peaked roof, except that type B vents need not comply with this provision when equipped with a vent cap approved by the Department of Buildings or previously approved by the Board of Standards and Appeals for the prevention of downdraft. A flue in an existing chimney may be used if a licensed plumber certifies that he has made a smoke test of the flue and found no gas escaping through its walls, and made a test of the draft and found it adequate. However, window or wall type heaters of the sealed combustion chamber type which have been approved by the Department of Buildings or previously approved by the Board of Standards and Appeals may be vented in accordance with the approval of the Board, except as provided in subdivision (d) of this section.

(d) No gas-fueled space heater, including a window or wall type recessed heater and no gas-fueled water heater, installed in a dwelling, shall be vented to an inner court unless it is connected to a chimney complying with the requirements of subchapter 15 of Chapter 1 of Title 27 of the Administrative Code (Building Code). Standard steel steam or water pipes are acceptable in such locations.

(e) Gas-fueled water heaters shall be located as close as practicable to a vent or flue. They should be so located as to provide short runs of piping to fixtures.

(f) Vent connectors shall consist of galvanized iron of not less than No. 26 U.S. gage [*sic*] in thickness, cement-asbestos pipe, approved type B vents, enameled steel pipe of a quality acceptable to the superintendent as heat and corrosion resistant, or other materials satisfactory to the superintendent.

(g) Vent connectors shall have a cross-sectional area at least equal to the area of the vent outlets of the appliance and shall have a minimum diameter or dimension of three inches.

(h) Outlet pipes and vents, on the exterior of a building, shall consist of standard water, steam or soil pipes, type B vents approved by the Department of Buildings or previously approved by the Board of Standards and Appeals, or other corrosion resistant materials satisfactory to the superintendent, all so connected as to prevent leakage at joints. Outlet pipes and vents on the exterior of a building shall be adequately supported and braced. Flues inside of buildings shall be constructed as low temperature chimneys. Type B vents may be used inside buildings when installed in accordance with the requirements of §27-887(d) of the Administrative Code (Building Code) and with the conditions of their approval.

(i) Only vent connections serving appliances located in one story of a building may be made to any flue. The cross-sectional area of any flue shall be equal to or greater than the total cross-sectional area of all vents connected to it, but in any case the least internal dimension shall be three inches.

(j) Vent connections may be made to a flue serving other heat producing appliances, above the connection of the other

Rules and Regulations

heat producing appliances, or the smoke pipe or vent connection from the gas appliance and the other heat producing device may enter the flue through a single opening if joined together by a Y fitting located as close as practical to the flue. The angle of intersection between the branch and the stem of the Y shall not exceed forty-five degrees. The area of the common outlet pipe shall not be less than the combined areas of the outlet pipes joined by the Y fitting.

(k) The horizontal run of vent pipe connectors shall not exceed three-fourths of the vertical rise of the flue to which the vent is attached, measured from the connection of the appliance to the top of the flue. A vent connector shall be pitched upward from the gas appliance with a slope of not less than one-fourth inch vertically for each foot of horizontal run.

(l) No dampers, steel wool or other obstructions shall be placed in any vent pipe or flue.

§40-40 Gas-Fueled Space Heaters Installed Prior to December 18, 1957.

(a) Gas-fueled space heaters installed prior to December 18, 1957, if of a type not approved by the Department of Health and the American Gas Association, shall be replaced by centrally supplied heat or by gas heaters approved by the said authorities on or before November 1, 1958, in any tenement and converted dwelling which contains ten or more apartments, and on or before November 1, 1959, in other tenements and converted dwellings.

(b) On or before the applicable dates given in subdivision (a) of this section, gas-fueled space heaters installed prior to December 18, 1957, in tenements and converted dwellings prescribed in said paragraph shall be made to comply with all the requirements of §§40-33 through 40-39.

§40-41 Gas-Fueled Water Heaters Installed Prior to December 18, 1957.

(a) On or before November 1, 1958, in any tenement and converted dwelling which contains ten or more apartments, and on or before November 1, 1959, in other tenements and converted dwellings, any gas-fueled water heater installed prior to December 18, 1957, if of a type not approved by the Department of Health, shall be replaced by a supply of hot water or by a water heater approved by said department.

(b) On or before the applicable dates given in §40-40(a), gas-fueled dwellings described in said paragraph shall be made to comply with all the applicable requirements of §§40-33 through 40-39, and all gas-fueled water heaters that have water heaters installed prior to December 18, 1957, in tenements and converted dwellings' sleeping rooms shall be removed.

(c) Any gas-fueled water heater so designed and arranged that it heats water in pipe coils placed at a distance from the hot water storage tank, installed prior to December 18, 1957, may be maintained in tenements and converted dwellings described in subdivision (a) of this section on and after the applicable dates given in said rule only if it is of a type approved by the Department of Health. However, no gas-fueled water heater shall be maintained in a sleeping room or bathroom.

§40-42 Maintenance of Space and Water Heaters.

(a) The owner of the tenement or converted dwelling and of the one and two family dwelling in which gas-fueled space and water heaters have been installed by him shall maintain each such appliance in a condition of good repair and in good

operating condition.

(b) On and after November 1, 1958, in any tenement and converted dwelling which contains ten or more apartments, and on and after November 1, 1959, in any other tenement and converted dwelling, where a tenant provided a space or water heater on October 1, 1957, each such appliance shall be made to comply with all the applicable requirements of these rules and shall be maintained in a condition of good repair and in good operating condition by the tenant.

(c) Should a tenant fail to comply with the requirements of subdivision (b) of this section, it shall be the duty of the owner of the tenement or converted dwelling to provide centrally supplied heat and a supply of hot water, or if such apartment is eligible therefore [*sic*] and he so elects, to install and continuously maintain space and water heaters therein which shall comply with the requirements of these rules.

(d) On and after November 1, 1958, in any tenement and converted dwelling which contains ten or more apartments, and on and after November 1, 1959, in any other tenement and converted dwelling, where gas-fueled space or water heaters were provided by the tenant, and the ownership of such appliances passes from the tenant or successor tenant, or if any such space or water heaters are removed from gas-fueled space or water heater, or temporarily for the purpose of repairs, then such an apartment, except for the purpose of immediate replacement by another owner will be subject to the duties imposed on an owner by subdivision (c) of this section.

§40-43 Existing Appliances in Ineligible Locations. Where a gas-fueled space heater or water heater has heretofore been installed in a dwelling not complying with all the requirements of §40-21, nothing in these rules shall be construed to relieve the owner of his responsibility to provide for such dwelling centrally supplied heat and supply of hot water.

§40-44 [Reserved]

§40-45 Variations. Where there is a practical difficulty in carrying out the strict letter of the provisions of these rules, the Borough Superintendent may vary such provisions for a specific installation, provided the necessary safety is secured and the variance is not in conflict with Administrative Code.

CHAPTER 41 VENTING OF GAS WATER HEATERS AND OTHER GAS APPLIANCES IN MULTIPLE DWELLINGS

§41-01 Venting of Gas [*sic*] Water Heaters and Other Gas Appliances in Multiple Dwellings.

(a) This section shall apply to vents for gas burning water heaters within apartments of multiple dwellings as required by §27-887(d) of the Administrative Code (Building Code) and to gas appliances in rooms or spaces without a window opening to the outer air, used for living or sleeping within a multiple dwelling, where required by the provisions of §64 of the Multiple Dwelling Law.

(b) Vents shall consist of galvanized iron of not less than No. 26 U.S. gage [*sic*] in thickness, cement-asbestos pipe, metal asbestos pipe, enameled steel pipe of a quality acceptable to the Department as heat and corrosion resistant, or other materials satisfactory to the superintendent.

(c) Vents shall have a cross-sectional area at least equal to the area of the vent outlet of the appliance and shall have a

Rules and Regulations

minimum diameter or dimension of three (3) inches.

(d) Vents shall lead to a flue or to the outer air as follows:

(1) Several vents may be connected to a flue if the cross-sectional area of the flue is equal to or greater than the total cross-sectional area of all vents so connected. No vent from a water heater or other gas appliance within an apartment may be connected to a flue serving a central heating plant.

(2) Vents may be connected to [*sic*] flue serving appliances burning other than gas fuel provided the connection of the gas appliance to the flue is at least nine (9) inches above the connection of the other heat producing device, or through a suitable "Y" connection in a common vent pipe of proper diameter.

(3) Every flue to which a vent from a gas water heater is attached, shall extend to a distance of not less than four (4) feet above a flat roof, or two (2) feet above a pitched roof. Such flues on the exterior of a building, and the portions of the vent pipes on the exterior of a building, shall consist of standard water, steam or soil pipe, cement asbestos pipe, metal-asbestos pipe or other corrosion resistant material satisfactory to the Department. Flues and vent pipes on the exterior of buildings shall be adequately supported and braced. Flues within buildings shall be constructed as low temperature chimneys.

(4) Vents leading to an outside flue or terminating at the exterior of the building may pass through the upper part of a window if the vent is adequately secured in place and provided the vent is so arranged as to give minimum interference with the operation of the window, provided the area of the windows in the room after alteration equals or exceeds that required by law. Vents may also pass through an exterior wall by means of a metal sleeve placed in the wall. The metal sleeve shall consist of standard water, steam, or soil pipe, cement-asbestos pipe, or other approved material. The space between the sleeve and the vent shall be filled with incombustible material.

(5) Vent pipes may be terminated at the exterior of an outside wall of a building in which case the vents shall be turned upward for not less than ten (10) inches, except that for any vent pipes installed after June 30, 1955, the vertical rise of the vent pipe shall not be less than one and one-third times the length of the horizontal run of the vent pipe. No vent pipe shall terminate below the level of the top of a window unless at least three (3) feet distant from any part of the window. Vents shall be capped with an approved tee. Vents on the exterior of a building shall comply with the provisions of paragraph (4), subdivision (d) of this section as to the material that may be used.

(e) Vent pipes shall be installed so as to provide a minimum clearance of three (3) inches on all sides from combustible material. Vent pipes shall not pass through a floor unless approved by the superintendent.

(f) Where a vent pipe passes through a partition or roof constructed wholly or in part of combustible material, a ventilated metal thimble not less than six (6) inches larger in diameter than the pipe, shall be provided. Any material used to fill the space between the vent pipe and the thimble shall be incombustible.

(g) Every vent pipe serving as a gas water heater shall be provided with a draft hood unless the water heater has an approved built-in draft hood. The draft hood shall be approved by a recognized testing laboratory as conforming to nationally accepted standards. The draft hood shall be installed at the

flue collar or as near to the appliance as possible and in the position for which it was designed, with reference to horizontal and vertical planes. The relief opening of the draft hood shall not be obstructed.

(h) The horizontal run of vent pipe shall not exceed three-fourths of the vertical rise of the flue to which the vent is attached. The vent pipe shall be pitched upward from the water heater with a slope of not less than one-fourth inch vertically for each foot of horizontal run.

(i) No dampers, steel wool or other obstructions shall be placed in any vent pipe or flue.

(j) A permit shall be obtained from the Department of Buildings before any vertical flue or chimney is constructed.

CHAPTER 42 ENTRANCE DOORS, LOCKS AND INTERCOMMUNICATION SYSTEMS

§42-01 Entrance Doors, Locks and Intercommunication Systems.

(a) Bulkhead doors and scuttles shall have no key locks and shall not be locked by a key at any time. The only permissible and acceptable means of securing a bulkhead door or scuttle is by means of a movable bolt or hook on the inside.

(b) Section 15.10(n) of the current departmental rules and regulations in its last un-numbered paragraph provides as follows:

“All passageways required under these rules shall be not less than seven feet (7'0”) in height and not less than three feet (3'0”) in width and shall at all times be kept clear and unobstructed. Doors and gates at the end of such passageways are prohibited, except that a door or gate equipped with an approved-type knob or panic bolt which shall be readily openable from the inside will be permitted at the building line. Doors and gates provided with key locks or padlocks are prohibited.”

(c) Where an entrance door leading from a vestibule to the main entrance hall or lobby is equipped with one or more automatic self-closing and self-locking doors, the entrance door from the street to the vestibule need not be equipped with automatic self-closing and self-locking doors.

(d) Every entrance from the street, court, yard or cellar to a class A multiple dwelling erected or converted after January 1, 1968 containing eight or more apartments shall be equipped with automatic self-closing and self-locking doors. Such multiple dwelling, as aforesaid, shall also be equipped with an intercommunication system to be located at the required main entrance door.

(e) On or after January 1, 1969, every entrance from the street, court, yard or cellar to a class A multiple dwelling erected or converted prior to January 1, 1968 containing eight or more apartments, shall be equipped with automatic self-closing doors and self-locking doors and shall also be equipped with an intercommunication system.

(f) Every self-locking door required under this section shall be installed and maintained so as to be readily openable from the inside without the use of keys.

(g) The minimal devices acceptable for the intercommunication system shall be a bell or buzzer system, or a speaking and listening device to permit communication by voice between the occupant of each apartment and a person outside such required main entrance door, and a return buzzer

Rules and Regulations

mechanism to release or open the lock to the aforesaid required door.

(h) The bell and intercommunication system shall be located at the required main entrance door so that a person may readily reach the door when the unlocking buzzer is activated.

(i) No push button device shall be more than six feet from the floor and the speaking and listening device shall be installed to be not less than four feet and not more than five feet from the floor.

(j) The device or devices for the the intercommunication system installed in the apartment shall be readily accessible to the occupant.

(k) The device or devices for the the intercommunication system installed hereunder shall be of a type and kind approved by the Department of Buildings or previously approved by the Board of Standards and Appeals.

(l) Devices which have been previously installed and which are in good condition and performing in an adequate manner may, in the discretion of the department, be accepted.

CHAPTER 43 INSTALLATION OF SECURITY ITEMS IN MULTIPLE DWELLINGS

§43-01 Installation of Peepholes.

(a) These new peepholes, or door interviewers, must bear a label showing the approval of the Department of Buildings or the previous approval of the Board of Standards and Appeals.

(b) The peepholes must be so located as to enable a person in such housing unit to view from the inside of the entrance door any person immediately outside.

(c) The distance above the inside finished floor to the center of the peephole shall be approximately 5 feet.

(d) The cutout shall not affect the adequacy of any stiffening member of the door.

(e) Peepholes installed prior to the enactment of the legislation will be acceptable unless the cutout for the peephole has affected the adequacy of any stiffening member of the door.

§43-02 Installation of Two 50 Watt Lights at Front Entrance Way.*

(a) All electrical work shall be done in accordance with the requirements and approval of the Department of Buildings.

(b) The installation shall be a separate circuit or connected to the house line servicing the public halls.

(c) The lights shall be encased in a metal guard or shatterproof globe.

(d) The lights of at least 50 watts of incandescent or equivalent illumination shall be placed on each side of the front entrance-way at a height of between 7 to 11 feet above floor level adjacent to such entrance-way and adequate to light same.

**As promulgated, however provisions of the New York City Housing Maintenance Code may require high wattage requirements.*

§43-03 Installation of Viewing Mirrors in Self-Service Elevators.

(a) Mirrors shall be made of polished metal.

(b) Mirrors shall be of such size and so located on the car wall opposite the car entrance so that a person entering the elevator may have a complete view of the interior of the car. It shall not be necessary to provide a view floor and ceiling.

(c) The mirror shall be so located as not to interfere with or endanger passengers in the elevator.

(d) Mirrors shall be mounted and secured so that they cannot be readily removed by the public.

43-04 Installation of Lights in Rear Yards, Side Yards, Front Yards and Courts.

(a) All electrical work shall be done in accordance with requirements and approval of the Department of Buildings.

(b) The installation shall be a separate circuit or connected to the house line servicing the public halls.

(c) The light or lights, shall be of at least 40 watts of incandescent or equivalent illumination.

(d) The lights shall be so located as to adequately light all portions of the rear yards, side yards, front yards and courts.

(e) Lights are not required in an inner court that is accessible only from the interior of the building and to which access is restricted for clean-out purposes.

CHAPTER 44 EXEMPTIONS FROM FILING REQUIREMENTS

§44-01 Minor Alterations that do not Require the Filing of Applications and Plans for Building Alteration Permits with the Department of Buildings.

(a) The following items associated with one and two family dwellings shall be considered minor alterations within the meaning of §27-124 of the Administrative Code of the City of New York and shall not require the filing of applications and plans for building alteration permits with the Department:

(1) Fences of any material, including masonry fences, up to six feet high;

(2) Boiler room enclosures;

(3) Minor interior non-structural changes not increasing room count;

(4) Outdoor in-ground pools limited to 400 square feet in area, provided that there is an existing slop sink for indirect waste; and

(5) Greenhouses and temporary portable freestanding sheds erected on the same zoning lot as the main building, provided that the following requirements are met:

(i) The shed or greenhouse shall not exceed 120 square feet in area and shall not be more than 7'6" in height;

(ii) The shed or greenhouse shall not be located nearer than 3 feet from any lot line;

(iii) The shed shall not be permanently affixed to the land;

(iv) The shed shall not be used for storage of other than normal household goods; the greenhouse shall not be used for any use other than cultivating plants and

(v) There shall not be more than one such shed or greenhouse on any zoning lot.

(b) The following item(s) associated with multiple dwellings shall be considered a minor alteration within the meaning of §27-124 of the Administrative Code of the City of New York and shall not require the filing of applications and plans for building alteration permits with the Department:

(1) Open screen balcony enclosures.

(c) This rule shall not relieve any applicant of the obligation to file at other City agencies, when appropriate, including the Landmarks Preservation Commission and the City Planning Commission.

Rules and Regulations

CHAPTER 45 BUILDING PERMIT APPLICATION PROCEDURES

§45-01 Microfilming of Application Folders and Associated Documentation for Temporary and Final Certificates of Occupancy and Letters of Completion.

(a) *Purpose.* (1) To provide the procedure whereby the Department of Buildings will microfilm application folders and associated documentation for certificates of occupancy, temporary certificates of occupancy and/or letters of completion.

(b) *Procedure.*

(1) The Department requires that the contents of approved folders be microfilmed twice.

(i) Prior to permit, the contents of approved folders, including but not limited to application plans and documents, must be microfilmed by the applicant using an outside vendor.

(ii) At the time of request for the first temporary and final certificate of occupancy and/or letter of completion, a second microfilming must be performed by the Department of Buildings.

(2) The minimum fee for microfilming by the Department shall be \$35.00 and shall be paid at the time the initial job application is filed. This fee covers microfilming of the application file at the time a certificate of occupancy or letter of completion is issued. In the event filming requires more than two fiche, an additional \$10.00 per fiche will be charged at the time the temporary or final certificate of occupancy or letter of completion is issued. In the event the Department has microfilmed the folder and associated documentation upon issuance of a temporary certificate of occupancy, there will be no charge for the microfilming of those documents added to the folder for the final certificate of occupancy if less than twenty (20) pages. If the added documents are more than 20 pages, the excess will be charged at \$10.00 per fiche.

(3) The Department will send a copy of the microfilm of the application, associated documentation and certificate of occupancy or letter of completion to the applicant after a certificate of occupancy or letter of completion is issued.

CHAPTER 46 AUTHORIZED REPRESENTATIVES

§46-01 Persons authorized to perform inspections, tests, certifications, and other functions on behalf of the Department.

(a) *Authorized representatives.* Persons authorized to perform inspections, other than officers and employees of the Department, shall include the following:

(1) Professional engineers and registered architects licensed under the New York State Education law are authorized to review plans and satisfy objections issued at plan examination and perform tests and inspections required by title 26 and 27 of the New York City Administrative Code ("the code"), in accordance with code requirements and all applicable rules and regulations of the Department;

(2) Professional engineers and registered architects licensed under the New York State Education Law and master plumbers and master fire suppression piping contractors licensed by the Department are authorized to inspect and witness tests for plumbing, standpipes, and sprinklers in accordance with the code, to the extent they are qualified by the terms of their licenses and experience;

(3) Professional engineers, registered architects, licensed master

plumbers, and representatives of utility companies may also witness tests of gas piping systems in accordance with the code and applicable rules and regulations of the Department;

(4) Other persons and entities licensed by the Department under title 26 of the code are authorized to perform inspections of work performed under their licenses pursuant to the code and applicable rules and regulations of the Department;

(5) Land surveyors and landscape architects licensed under the New York State Education Law are authorized to review plans and to perform inspections of work performed under their licenses pursuant to the code and applicable rules and regulations of the Department;

(6) Qualified boiler inspectors are authorized to perform boiler inspections under section 27-793(b) of the code and rules promulgated thereunder;

(7) Private elevator inspection agencies certified under Section 11-01 of the rules of this Department are authorized to perform and witness elevator inspections and tests in accordance with code provisions; and

(8) Private electrical inspection agencies certified under section 35-01 of the rules of this Department are authorized to perform electrical inspections.

(b) The authorized representatives listed in subdivision (a) above shall identify themselves by producing copies of their applicable licenses or certifications and shall maintain liability insurance in accordance with applicable code requirements.

(c) Except as otherwise permitted in the code, the authorized representative shall personally conduct the inspections or tests.

(d) Authorized representatives may only perform such inspections and tests for which they are qualified by the terms of their licenses and their experience.

(e) Failure to comply with the applicable law and rules and regulations of the Department shall be grounds for suspension or revocation of an authorized representative's authority to conduct inspections on behalf of the Department.

CHAPTER 47 LICENSED OIL-BURNING EQUIPMENT INSTALLERS

§47-01 Requirement of a seal for use by licensed oil-burning equipment installers.

(a) At the time of issuance of a class A or class B oil-burning equipment installer license, upon payment of the required fee, the commissioner shall issue to the licensee a seal containing the full name of the license holder, the words "licensed oil-burning equipment installer-Class A" or "licensed oil-burning equipment installer-Class B", and the license number. Except as set forth in paragraph (f) below, the license holder shall not be entitled to perform work or hold himself or herself out as a licensed oil-burning equipment installer until such seal has been obtained.

(b) The fee for obtaining a seal shall be one hundred dollars. The biennial renewal fee to retain such seal shall be fifty dollars.

(c) If the seal is lost, and an affidavit is submitted by the licensee establishing such fact, a new seal shall be issued by the commissioner upon application and payment of seventy-five dollars.

(d) All documents which are required to be filed with this Department or other government agency in connection with

Rules and Regulations

work by such licensee shall bear the stamp of the seal as well as the signature of such licensee.

(e) The seal shall remain the property of the City of New York. Upon revocation of an oil-burning equipment installer's license or death of the licensee or failure of a licensee to renew such license, the seal must be surrendered to the Department.

(f) Persons who hold class A or class B oil-burning equipment installer licenses on the effective date of this rule must obtain their seals within 90 days of the effective date of this rule. Prior to the expiration of this 90 day period, such licensees may perform work under their licenses and hold themselves out as licensed oil-burning equipment installers without the use of a seal.

CHAPTER 48 CONSTRUCTION SUPERINTENDENTS

§ 48-01 General Provisions

(a) *Definitions.* For the purposes of this chapter, the following terms shall have the following meanings:

(1) *Commissioner.* The term "Commissioner" shall mean the Commissioner of the Department of Buildings or his or her designee.

(2) *Construction superintendent.* The term "construction superintendent" shall mean the individual responsible for those duties defined in §48-02 of this chapter and registered in accordance with the provisions of §48-03 of this chapter.

(3) *Days.* The term "days" shall mean calendar days unless otherwise specified.

(4) *Department.* The term "Department" shall mean the Department of Buildings.

(5) *Job.* The term "job" shall mean a construction project that is the subject of one or more Department-issued demolition or new building permits for buildings up to and including 14 stories, or other structures or permit types as the Commissioner may designate, excluding one-, two- and three-family dwellings. Beginning one year after the effective date of this rule, the term "job" shall also apply to Department-issued demolition or new building permits for a one-, two- or three-family dwelling. The term "job" shall not include work for which a site safety manager has been designated pursuant to the Building Code and the Department's rules.

(6) *Permittee.* The term "permittee" shall mean the individual applying for and receiving Department-issued job permits.

(b) *Permits.*

(1) Beginning on the 180th day following the effective date of this rule, no demolition or new building permit shall be issued or renewed for a job until the permittee or his or her representative has designated on the permit application form for the job a construction superintendent registered with the Department of Buildings in accordance with the provisions of §48-03 and, at the permittee's option, up to three registered construction superintendents as alternates. Except where an architect or engineer is designated, the

construction superintendent and the alternate(s) shall be employees of the permittee.

(2) Where a registered construction superintendent is relieved of duties by the permittee, all jobs on which the designated construction superintendent is relieved shall be stopped and the permits shall be deemed suspended unless he or she is replaced by another registered construction superintendent within a period of five (5) business days from the date the construction superintendent has been relieved of such duties.

§ 48-02 Duties.

(a) *Availability and Compliance.* A construction superintendent shall have responsibilities including, but not limited to:

(1) availability to the Department at all times, including emergencies; advising the Department of contact information and changes thereto; engaging in sound construction practices; acting in a reasonable and responsible manner to maintain a safe construction site; reporting immediately to the Department any fatality, injury to persons resulting in hospitalization or injury to property occurring on or adjacent to the job site that arises from the construction work; and

(2) to the extent that an architect or engineer is not responsible, assuring compliance with the applicable approved plans and the requirements of sections 27-132(b), 27-221, Subchapter 19 of Chapter 1 of Title 27 and all other provisions of the Administrative Code and rules and regulations as they relate to the duties of a person superintending work.

(b) *Obligation to cooperate with inquiries.* All registered construction superintendents shall cooperate in any investigation by the Department, or other city or law enforcement agency, into the activities at any job site under their supervision and shall provide prompt, accurate and complete responses to reasonable inquiries by the Department and other agencies about the conduct of such business.

(c) *Limitation of Duties.*

(1) An individual may be designated as construction superintendent for that number of jobs he or she can adequately supervise, to a maximum of ten (10) at any one time.

(2) Upon a request made in writing by a registered construction superintendent, the Commissioner may approve an increase in the maximum number of jobs to be supervised involving one-, two- or three-family dwellings only, up to a maximum of twenty-five (25) at any one time, provided the jobs occur on contiguous tax or zoning lots.

(d) *Obligation to comply with an order of the Commissioner.* All registered construction superintendents shall comply with an order of the Commissioner.

(e) *Obligation to advise Department of relief from duties.*

Rules and Regulations

(1) All registered construction superintendents shall immediately notify the Department in writing in a form or other manner determined by the Commissioner upon being relieved of their duties in connection with any job permit on which they are designated.

(2) All permittees shall immediately notify the Department in writing in a form or other manner determined by the Commissioner upon the relief of duty of a construction superintendent who is designated upon a permit application filed by the permittee.

§ 48-03 Registration of Construction Superintendents.

(a) *Effective Date.* On or after the 180th day following the effective date of this rule, all individuals serving as construction superintendents for jobs must be registered with the Department, except as otherwise provided in subdivision f of this section.

(b) *Registration with Department.* The Department shall register all construction superintendents who meet the qualifications herein.

(c) *Form and manner of registration.* An application for registration shall be submitted in a form and manner determined by the Commissioner, including electronically, and provide such information as the Commissioner may require.

(d) *Qualifications.* The Department shall issue a Construction Superintendent registration to an individual who shall, at the time of his or her application, submit proof that he or she:

(1) is at least 18 years of age;
(2) is able to read and write the English language; and either
(3) is a New York State Licensed Professional Engineer or Registered Architect or a Department certified site safety manager and has completed within three years immediately preceding the application:

(i) a seven-hour Site Safety Manager course approved by the Department; or

(ii) a 10-hour Occupational Safety and Health Standards for the Construction Industry course; or

(4) within the 10 years immediately preceding the application, has worked for five years in the capacity of construction superintendent as verified by employer or union affidavit and has completed within three years immediately preceding the application:

(i) a seven-hour Site Safety Manager course approved by the Department; and

(ii) a 10-hour Occupational Safety and Health Standards for the Construction Industry course; or

(5) within the 10 years immediately preceding the application, has five years of on-site experience in the construction industry as a carpenter, mason, or inspector of building construction as verified by employer or union affidavit and has satisfactorily completed within three years immediately preceding the application:

(i) a 40-hour Site Safety Manager course approved by the Department; and

(ii) a 10-hour Occupational Safety and Health Standards for the Construction Industry course; or

(6) has satisfactorily completed such equivalent course(s) approved by the Commissioner, including those in electronic format.

(e) *Audits.* Applications for registration are subject to audit at any time. Such audit may also be made at any time upon receipt of complaints or evidence of falsification.

(f) *Incumbent application deadlines.*

(1) Notwithstanding the provisions of subdivision a of this section, where, within six (6) months prior to the effective date of this rule, an individual has been designated on a demolition, alteration 1 or new building permit as a construction superintendent and is actively performing the duties of a construction superintendent on the effective date of this rule, he or she may continue to perform such duties without complying with the foregoing if, within one hundred eighty (180) days after the effective date of this rule, application for registration is made to the Department. In such case all necessary evidence, such as course completion certificates and employment affidavits, shall be furnished within one year of such effective date.

(2) One year after the effective date, all individuals serving as job construction superintendents must be registered as such with the Department. All incumbents who are not registered as of that date shall be deemed disqualified from that position and, unless replaced by a registered construction superintendent within a period of five (5) business days from the date of such disqualification, all job permits on which the incumbent has been designated since the effective date, shall be deemed revoked.

(g) *Registration term.* Registrations issued under this rule are valid for three years from the date of issuance.

(h) *Registration Fees.* The initial fee for registration in accordance with these rules is one hundred dollars (\$100.00).

(i) *Renewals.*

(1) Renewal applications shall be submitted between thirty (30) and sixty (60) days prior to the expiration date of the registration.

(2) The fee for timely renewal is fifty dollars (\$50.00). Renewals not submitted in a timely manner shall be subject to a late surcharge of fifty dollars (\$50.00).

(3) Timely renewal applications shall be accompanied by proof that the applicant has, during the one-year prior to renewal, successfully completed:

(i) a seven-hour Site Safety Manager course approved by the Department; or

(ii) any equivalent course(s) approved by the Commissioner, including those in electronic format.

Rules and Regulations

(4) Renewals not filed within one year of registration expiration shall be subject to the requirements of subdivision d of this section.

§ 48-04 Disciplinary Actions.

(a) *Suspension or revocation of registration.*

(1) After notice and the opportunity for a hearing in accordance with the rules of the Department, a construction superintendent registration may be suspended or revoked by the Commissioner, with or without the imposition of penalties, or penalties may be assessed, for violation of any provision of the Building Code, the rules of the Department, the Zoning Resolution or any other applicable laws or rules, inclusive of the provisions of subdivision b of this section. Unless replaced by another registered construction superintendent within five (5) business days of such suspension or revocation, all jobs on which the construction superintendent is designated shall be stopped and the permits shall be deemed suspended until such time as a duly registered construction superintendent is designated or such permits expire.

(2) Notwithstanding the provisions of paragraph one of this subdivision, where the Commissioner finds that emergency action is necessary to protect public safety, the Commissioner may suspend immediately upon notice the registration of a construction superintendent and shall schedule a hearing to be held within fifteen (15) days of such notice in accordance with the rules of the Department. At the conclusion of that hearing, the Administrative Law Judge may lift the suspension, revoke the registration, or, alternatively, if the Administrative Law Judge finds that the summary suspension of the registration was appropriate, but that further hearings are necessary to make a final determination of the charges, the Administrative Law Judge may make a finding as to the need for further hearings and continue the suspension pending such further hearings. Upon such initial suspension, unless replaced by another registered construction superintendent within five (5) business days of the suspension by the Commissioner, all jobs on which the construction superintendent is designated shall be stopped and the permits shall be deemed suspended until such time as a duly registered construction superintendent is designated or such permits expire.

(b) *Penalties.* Penalties assessed pursuant to paragraph one of subdivision a of this section shall not exceed one thousand dollars (\$1,000.00) for each violation by a construction superintendent of any of the rules of the Department, the Building Code, the Zoning Resolution or any other applicable laws or rules including, but not limited to any of the following:

(1) Failure, upon receipt of an order or violation notice, to take the action called for in such order or notice.

(2) Failure to respond in a timely manner to any Department inquiry.

(3) Performance or supervision of construction work in a manner contrary to the requirements of applicable codes, rules, the Zoning Resolution or applicable approved plans as they relate to the duties of a person superintending work.

(4) Fraudulent dealing or misrepresentation.

(5) The conviction of a criminal offense relating to offering or receiving a bribe, giving or receiving unlawful gratuities, engaging in official misconduct, or other corruption-related acts, where the underlying act arises out of the registrant's occupation or business dealings with the City of New York or with any other governmental entity.

(6) The making of any false statement in an application for registration or the renewal of a registration or other application or registration required by the Department, or in any proof or instrument in writing in connection therewith.

(7) Exceeding the maximum number of permissible jobs to which the construction supervisor may be designated.

(8) Failure to immediately notify the Department in writing upon being relieved from duties for any job upon which the construction superintendent is designated.

§ 48.05 [*sic*] Obligations of Others.

Nothing in this rule is intended to alter or diminish any obligation otherwise imposed by law on others, including but not limited to, the owner, construction manager, general contractor, contractor, materialman, architect, engineer, site safety manager, land surveyor, or other party involved in a construction project to engage in sound engineering, design, and construction practices, and to act in a reasonable and responsible manner to maintain a safe construction site.

§48-06 Severability.

If any clause, sentence, paragraph, section or part of this rule or the application thereof to any person or circumstance shall for any reason be adjudged by a court of competent jurisdiction to be invalid, such judgment shall not affect, impair or invalidate the remainder of this rule or the application thereof to other persons or circumstances, but shall be confined in its operation to the clause, sentence, paragraph, section or part thereof directly involved in the controversy in which such judgment shall have been rendered and to the person or circumstance involved.

CHAPTER 49 OUTDOOR SIGNS

Subchapter

A *General Provisions*

B *Registration of Outdoor Advertising Companies*

Rules and Regulations

- C *Administrative Remedies of the Department Pursuant to Section 26-260(d) of the Administrative Code*
- D *Removal, Storage, and Disposal of Signs and Sign Structures*
- E *Application for Sign Work Permit*

Subchapter A - General Provisions

§ 49-01 Definitions. For the purposes of this chapter, the following terms shall have the following meanings:

Accessory sign. The term “accessory sign” shall mean an accessory sign within the meaning and intent of the term “accessory use” as defined in section 12-10 of the Zoning Resolution.

Advertising sign. The term “advertising sign” shall mean an “advertising sign” as defined in section 12-10 of the Zoning Resolution.

Affiliate outdoor advertising companies. The term “affiliate outdoor advertising companies” or “affiliate OACs” shall mean two or more outdoor advertising companies interrelated with one another such that one or more of such outdoor advertising companies maintains an interest in the others as hereinafter described: An outdoor advertising company (“OAC”) (A) has an interest in another OAC (B) where one or more of the following are present:

- (1) A owns 10 percent or more of the voting stock of B, where B is a stock-issuing entity;
- (2) A is a general partner in B, where B is a partnership or joint venture;
- (3) A has an ownership interest of 10 percent or more in B, in a form not otherwise described in (1) or (2) above, where such ownership interest confers a power or right to vote or exercise similar control over the affairs of B proportionate to such ownership interest;
- (4) A has one or more officers in common with B;
- (5) A has one or more key managers (chief executive officer; chief financial officer; chief operating officer; or persons with equivalent functions, irrespective of organizational title) in common with B;
- (6) A, by agency or other agreement, whether written or oral, conducts part or all of B’s outdoor advertising business or has the power or right to direct part or all of B’s outdoor advertising business;
- (7) A, by way of advertising, promotions or other methods, holds itself out as having the authority to, via a shared inventory arrangement, sell or lease space on signs situated on buildings or premises within the city, for outdoor advertising purposes, where the ownership, leasehold, license or other form of site control with respect to such signs is held by B.

For the purposes of this chapter both A and B shall be known and referred to individually by the term “affiliate OAC” or “affiliate” and collectively by the term “affiliate OACs” or “affiliates.”

Affiliates shall be jointly and severally liable for compliance with this chapter. Where affiliation is established only by virtue of a shared inventory of signs, sign structures or sign locations as described in example (7) above, responsibility for compliance and any resulting liability shall be limited to the extent of such shared inventory.

Affiliated outdoor advertising company. The term “affiliated outdoor advertising company” or “affiliated OAC” shall mean a single OAC that has authorized a responsible affiliate to act on its behalf for registration in accordance with this chapter.

Applicant. The term “applicant” shall mean an OAC that has filed an application for registration with the Department as required by section 26-260 of the Administrative Code and subchapter B of this chapter. Except where application is made pursuant to section 49-12(a)(3) of this chapter, the party holding fee or the dominant lease to a sign, sign structure or sign location, shall act as the applicant. With respect to an application for registration filed on behalf of an affiliated OAC the term “applicant” shall mean the responsible affiliate.

Approach. The term “approach” as found within the description of arterial highways indicated within appendix C of the Zoning Resolution, shall mean that portion of a roadway connecting the local street network to a bridge or tunnel and from which there is no entry or exit to such network.

Arterial highways. The term “arterial highways” shall mean arterial highways as defined by section 26-253(c) of the Administrative Code.

Commissioner. The term “Commissioner” shall mean the Commissioner of Buildings or his/her designee.

Days. The term “days” shall mean calendar days.

Department. The term “Department” shall mean the Department of Buildings.

Material change. The term “material change” shall mean a change in information supplied to the Department on an application form where the Department has indicated on such form by asterisk or otherwise that the information to be supplied is considered by the Department to be significant.

Non-conforming sign. The term “non-conforming sign” shall mean a sign that is “non-conforming” as defined by section 12-10 of the Zoning Resolution. The extent of the “non-conforming” use status shall be as set forth in sections 32-66, 42-55, and 42-58 of the Zoning Resolution.

Outdoor advertising business. The term “outdoor advertising business” shall mean “outdoor advertising business” as defined by section 26-259(c) of the Administrative Code. For the purposes of this rule, property owners and managers shall not be considered engaged in the outdoor advertising business where they are involved strictly to the extent of leasing space on property they control to an independent registered OAC that has registered the sign within its sign inventory. Such exclusion shall not apply where the property owner/manager has any interest in an OAC or role in any aspect of the OAC’s operation or management.

Rules and Regulations

Outdoor advertising company. The term “outdoor advertising company” or “OAC” shall mean “outdoor advertising company” as defined by section 26-259(b) of the Administrative Code.

Responsible affiliate. The term “responsible affiliate” shall mean the applicant that is authorized, by written instrument filed with the Department, to file an application for registration and to otherwise act on behalf of an affiliated OAC and receive all notices required to be sent under this chapter on behalf of such affiliated OAC. For the purposes of this chapter any direction or requirement imposed upon an OAC shall, with respect to an affiliated OAC, be undertaken by the responsible affiliate on behalf of the affiliated OAC and such affiliated OAC shall be bound by the act or failure to act of such responsible affiliate.

Responsible officer. The term “responsible officer” shall mean an officer or official of an OAC who is authorized to bind and commit such OAC and any affiliate(s).

Sign. The term “sign” shall mean a sign as defined in section 12-10 of the Zoning Resolution. Such term shall not include any sign erected upon property not subject to Department jurisdiction. Each sign face shall be a sign.

Sign inventory. The term “sign inventory” shall mean the list of signs, sign structures and sign locations under the control of an OAC, responsible affiliate or affiliated OACs as required and specified by section 26-261 of the Administrative Code and section 49-15 of this chapter.

Sign location. The term “sign location” shall mean sign location as defined by section 26-259 (f) of the Administrative Code.

Sign structure. The term “sign structure” shall mean the supports or uprights, including the sign face(s), whether attached to a building or other structure or freestanding, of a sign.

Within view. The term “within view” shall mean that part or all of the sign copy, sign structure, or sign location that is discernable.

Work permit. The term “work permit” shall mean a permit to erect, alter or install signs or sign structures issued pursuant to section 27-177 of the Administrative Code.

§49-02 Obligation to cooperate with inquiries. All OACs and all principals thereof, shall cooperate with Department investigations into the conduct of the outdoor advertising business within the City of New York, and shall provide prompt, accurate and complete responses to reasonable inquiries by the Department about the conduct of such business.

§49-03 Obligation to comply with an order of the Commissioner. OACs shall be obligated to comply with any order issued by the Commissioner pursuant to this chapter.

§49-04 Severability. If any clause, sentence, paragraph, section or part of this rule or the application thereof to any person or circumstance shall for any reason be adjudged by a court of competent jurisdiction to be invalid, such judgment shall not affect, impair or invalidate the remainder of this rule or the application

thereof to other persons or circumstances, but shall be confined in its operation to the clause, sentence, paragraph, section or part thereof directly involved in the controversy in which such judgment shall have been rendered and to the person or circumstance involved.

Subchapter B - Registration of Outdoor Advertising Companies

§49-11 Effective dates.

(a) On and after the 60th day after the effective date of this chapter, it shall be unlawful for an OAC to engage in the outdoor advertising business, or, by way of advertising, promotions or other methods, hold itself out as engaging in the outdoor advertising business, unless such OAC is registered with and has been issued a registration number by the Department and such registration has not expired or been revoked. Notwithstanding the foregoing provision, an OAC that is in existence on the effective date of this chapter may continue to do business as an OAC pending the issuance of a registration number if such OAC has filed a registration application pursuant to section 49-12 of this chapter on or prior to the 60th day after the effective date of this chapter and such application has not been rejected by the Department in accordance with subdivision c of such section.

(b) On and after the 60th day after the effective date of this chapter, it shall be unlawful for an OAC to sell or otherwise transfer control of a sign, sign structure, or sign location or any right of such OAC to sell, lease, market, manage, or otherwise make space on a sign, or sign structure, or at a sign location available to others for advertising purposes, to an OAC other than one that is registered in accordance with this chapter and that has been issued a registration number by the Department and such registration has not expired or been revoked, or to a OAC that has timely filed for registration pursuant to section 49-12 of this chapter and such application has not been rejected by the Department.

(c) On and after the 60th day after the effective date of this chapter it shall be unlawful to erect, alter, install, maintain, attach, affix, paint on, or in any other manner represent on a building or premises any sign that is under the control of an OAC unless such OAC is registered in accordance with this chapter, and has been issued a registration number by the Department and such registration has not expired or been revoked or, with respect to an OAC that is in existence on the effective date of this chapter, such OAC has filed a registration application pursuant to section 49-12 of this chapter on or prior to the 60th day after the effective date of this chapter and such application has not been rejected by the Department in accordance with subdivision c of such section.

§49-12 Application for registration.

(a) The application for registration or the renewal of registration shall contain all of the information required by the application form and these rules. Except where an application is filed pursuant to subsection (3) below, the party holding fee or the dominant lease to the sign, sign structure or sign

Rules and Regulations

location, shall act as the applicant for registration. An applicant shall:

- (1) file an application for registration and be issued an OAC registration number; or,
- (2) where an affiliated OAC exists, file an application for registration on behalf of itself and any affiliated OAC only to the extent of their shared control of any sign(s), sign structure(s), and sign location(s), and each such shared inventory shall be issued the OAC registration number that has been assigned to the applicant; or,
- (3) file a single application for registration on behalf of itself and every affiliated OAC, including all signs, sign structures, and sign locations under the control of the applicant and every affiliated OAC.

A responsible officer of the applicant shall certify the completeness and accuracy of the application and accompanying documents. A responsible officer of the affiliated OAC shall authorize the applicant to submit an application and act on behalf of the affiliated OAC. The Department shall act upon the application either by accepting the application or by notifying the applicant of deficiency in accordance with subdivision c of this section promptly but not later than 60 days after the date of receipt of the application, except that on or before such 60th day, the Commissioner may on good cause shown and upon notification to the applicant, extend such time for an additional 45 days. If the Department fails to act upon the application within such 60-day period or, where applicable, within such further 45-day period, the application shall be deemed accepted.

(b) The Department shall accept applications complying with the provisions of these rules and other applicable law. An OAC registration number shall be issued to the applicant of each accepted registration application. Where the application is for the renewal of an existing registration, the applicant shall be notified of such acceptance.

(c) The Department may reject an application for registration or for the renewal of registration if it finds that the application, including the accompanying listing of sign inventory required by section 49-15 of this chapter, is not complete and accurate or all required documents have not been submitted with the application. Before rejecting an application, the Department shall provide the applicant with an explanation of the deficiency and a period of time, but not more than 45 days, within which the applicant may submit a corrected application and any missing documents. Upon written request and for good cause, the Commissioner may extend the time for submitting a corrected application.

(d) An OAC registration number issued by the Department pursuant to this section shall not be transferable.

(e) An OAC shall notify the Department within 30 days thereof of any material change in the information provided in the most recent registration or renewal application submitted pursuant to this chapter. Where the material change involves the addition of an affiliated OAC, such additional affiliated OAC shall not do business as an OAC until notice of such material change is received.

§49-13 Term and fees.

(a) The term of the registration shall be for two years commencing on the date of issuance of an OAC registration number. The fee for the initial registration shall be \$1,500 per applicant, plus \$125 for each: sign; sign structure vacant of signage; and tax lot vacant of both signage and sign structures, listed in the sign inventory. The biennial registration renewal fee shall be \$750 per applicant, plus \$50 for each: sign; sign structure vacant of signage; and tax lot vacant of both signage and sign structures, listed in the sign inventory. The fee per material change shall be \$25.

(b) A registration renewal application shall be filed no sooner than 90 or later than 60 days prior to the expiration date of the current term of the registration. Notwithstanding the renewal fee set forth in subdivision (a), where a registration renewal application is submitted later than 60 days before the expiration of the current term of the registration, the renewal fee shall be \$1500 per applicant OAC, plus \$125 for each: sign; sign structure vacant of signage; and tax lot vacant of both signage and sign structures, listed in the sign inventory. A registration renewal application may not be submitted after the expiration of the current term of the registration. Nothing in this section shall prohibit an OAC with an expired registration from filing a new application for registration, subject to the filing requirements and fees of an initial registration application.

§49-14 Acceptable type of security.

(a) An applicant shall maintain security in the form of a letter of credit from an issuing bank or other security acceptable to the Department for all signs included in its inventory. Proof of such security must be filed with the Department with the initial application for registration and with all registration renewal applications. OACs may post one letter of credit or other security acceptable to the Department with respect to all affiliates or separate security for each affiliated OAC. The maximum number of letters of credit or other security acceptable to the Department shall not exceed the total number of signs in the inventory. The security must be in full force and effect from and after the date of registration. When a letter of credit or other security acceptable to the Department expires, is cancelled, is not renewed or for any reason becomes unenforceable, it shall be replaced forthwith and notice of such replacement shall be filed with the Department within 30 days thereafter. The bank shall be required to notify the Department promptly in the event of cancellation, failure to renew or other event that would render the security unavailable to the Department.

(b) The amount of security shall be \$25,000 for the first 20 signs in the sign inventory, plus \$10,000 for each additional 20 signs, or part thereof.

(c) Replenishment. The Department shall draw upon the security in accordance with applicable law. Upon the Department drawing upon the security, the OAC or responsible affiliate shall replenish the amount within 14 days of notice by regular mail from the Department to the OAC,

Rules and Regulations

or, if applicable, such responsible affiliate. Evidence thereof shall be submitted to the Department within 30 days.

§49-15 Sign inventory to be submitted with registration application.

(a) In addition to the information and documentation required by section 49-12(a) of this chapter, an applicant shall submit, pursuant to section 26-261 of the Administrative Code, a sign inventory that shall include all signs, sign structures and sign locations located (1) within a distance of 900 linear feet from and within view of an arterial highway; or (2) within 200 linear feet from and within view of a public park of one half acre or more. Such sign inventory shall be filed together with the registration application and each renewal registration application. The sign inventory submitted in connection with the renewal registration application shall include all material changes since the last registration or renewal registration application, and shall be accompanied by a statement that identifies all material changes since such prior registration. A registration application or renewal application submitted without such sign inventory or statement shall not be considered complete and may be rejected in accordance with subdivision (c) of section 49-12 of this chapter.

(b) A sign inventory submitted by a responsible affiliate on behalf of:

- (1) an affiliated OAC, in accordance with subdivision (a)(2) of section 49-12 of this chapter, shall include all signs, sign structures and sign locations under the shared control of such responsible affiliate and affiliated OAC; or,
- (2) every affiliated OAC, in accordance with subdivision (a)(3) of section 49-12 of this chapter, shall include all signs, sign structures and sign locations under the control of such responsible affiliate and every affiliated OAC.

(c) The sign inventory shall be accompanied by a signed statement of a responsible officer of the OAC or, if applicable, the responsible affiliate, stating that the listing of its inventory is a complete listing of all signs, sign structures and sign locations under its control, subject to section 26-261 of the Administrative Code.

(d) The sign inventory shall be submitted on forms to be prescribed by the Department and shall include the information specified on such forms for each sign, sign structure and sign location including, but not limited to, the following:

- (1) For each sign, sign structure and sign location, the public park and/or arterial highway to which it is proximate pursuant to section 49-15(a) shall be identified, and its distance in feet from such public park or arterial highway shall be listed. Such distance shall be calculated as the length of a horizontal plane extending between a vertical plane reflecting the edge of the sign, sign structure or sign location closest to the park or arterial highway and a vertical plane reflecting the portion of the park or highway closest to the sign, sign structure or sign location. Where a sign location is vacant of buildings or other structures to support signage, the measurement shall be from the edge of its tax lot closest to the public park and/or arterial highway.

(2) The block and lot numbers and the address, if one exists, for the premises of each sign, sign structure and sign location.

(3) The size of each sign and sign structure described in linear feet and inches.

(4) The height in feet and inches of the highest portion of each sign and sign structure above the curb level.

(5) Each sign shall be identified as either "advertising" or "non-advertising." To the extent a sign is a non-conforming sign, it must further be identified as "non-conforming advertising" or "non-conforming non-advertising." A sign identified as "non-conforming advertising" or "non-conforming non-advertising" shall be submitted to the Department for confirmation of its non-conforming status, pursuant to section 49-16 of this chapter.

(6) For each accessory sign, the name and mailing address of the business to which the sign directs attention, the nature of such business and the square footage of the floor space occupied by such business on the zoning lot.

(7) The name and address of all parties with an interest in the premises where each sign, sign structure and sign location is situated.

(8) The name and address of all parties with an interest in the sign or sign structure.

(9) A diagram, labeled with the information required by (1), (2) and (3) above, eight and one-half by eleven inches in size, that shows the position of the sign, sign structure or sign location on the lot with the distance in feet to the proximate highway or park.

(10) Digitized and printed eight inch by ten inch color photographs, clearly showing a front view and, if practicable, a rear view of the entire sign and sign structure and the building or other structure to which the sign or sign structure is attached.

(11) The work permit for the erection, installation, or most recent alteration of the sign or sign structure. To the extent such document is unavailable, the Department may accept a statement of diligent search.

(12) For each conforming sign, the name and license number of the master or special sign hanger who hung or erected each sign.

(13) Whether the sign is illuminated and if so whether such illumination is indirect as such term is defined in section 12-10 of the Zoning Resolution. If the sign is illuminated, the sign inventory shall include the permit number assigned by the Electrical Division of the Department for the associated power connection and if applicable, the illuminated sign permit number.

(14) Where a sign inventory is submitted on behalf of affiliated OAC(s), the legal name of the OAC that markets or manages each sign, sign structure or sign location and the legal name of the OAC with an ownership interest in each such sign, sign structure or sign location, if different, shall be identified.

(15) With respect to each sign that has been identified in the sign inventory as a non-conforming sign, the following

Rules and Regulations

additional information shall be included with the registration application:

a. The Zoning Resolution section that establishes the sign as a non-conforming sign.

b. Evidence that the non-conforming sign existed and the size of the sign that existed as of the relevant date set forth in the Zoning Resolution to establish its lawful status. Acceptable evidence may include permits, sign-offs of applications after completion, photographs and leases demonstrating that the non-conforming use existed prior to the relevant date. Affidavits, Department cashier's receipts and permit applications, without other supporting documentation, are not sufficient to establish the non-conforming status of a sign. The submitted evidence must specifically establish the non-conforming aspect of the sign. For example, where evidence is submitted to establish that a sign is a non-conforming advertising sign, proof that the sign was erected, but that does not establish that it was advertising, will not be sufficient.

c. Affidavit signed by the registered architect or professional engineer, that he or she reasonably believes the sign to be non-conforming based on the evidence submitted.

(1) A responsible officer of the OAC shall co-sign the affidavit, that he or she reasonably believes the sign to be non-conforming based on the evidence submitted, and that to the best of his or her knowledge there has not been any discontinuance of the non-conforming use for two or more years.

(e) Except as to non-conforming signs, the sign inventory shall be accompanied by a certification by a registered architect or licensed professional engineer, co-signed by a responsible officer of the OAC, that he or she has personal knowledge that the signs in the sign inventory are in compliance with the Zoning Resolution.

(f) The Department shall issue to each sign, or if vacant of signage, each sign structure and sign location listed in a sign inventory of a registered OAC, a "sign identification number."

(g) The Department's acceptance of an application for registration or for the renewal of registration, and the issuance of an OAC registration number to an applicant or a sign identification number for any sign, sign structure or sign location in the sign inventory, shall not constitute a decision or determination by the Department that a sign or sign structure is lawful under the Zoning Resolution or that a sign may lawfully be erected at the sign location.

(h) An OAC shall amend its sign inventory to reflect material changes in its portfolio of signs. The amendment shall be made within 30 days after such change.

(i) The applicant shall provide a list of signs believed to be exempt from registration and not subject to Department jurisdiction and located (1) within a distance of 900 linear feet from and within view of an arterial highway; or (2) within 200 linear feet from and within view of a public park of one half acre or more.

§49-16 Non-conforming signs.

(a) With respect to each sign identified in the sign inventory as non-conforming, the registered architect or professional engineer shall request confirmation of its non-conforming status from the Department based on the evidence submitted in the registration application. The Department shall review the evidence submitted and accept or deny the request within a reasonable period of time. A sign that has been identified as non-conforming on the initial registration application may remain erected unless and until the Department has issued a determination that it is not non-conforming. The registration of the OAC and remaining sign inventory shall continue unimpeded while such a determination is pending.

(b) The Department shall maintain a list of all signs that it accepts as non-conforming.

(c) The Department may withdraw its acceptance of a non-conforming sign upon discovering evidence that the sign was improperly considered, or should no longer be considered, a non-conforming sign, and upon such withdrawal and after notice to the OAC, the sign must be removed pursuant to the Zoning Resolution.

§49-17 Information required on signs. On and after the 90th day after the approval of the OAC registration, all signs included in an OAC's inventory shall have posted thereon the name of the OAC to which it is registered, the OAC registration number and, unless a permit is not required, the permit identification number for the installation, alteration or erection of such sign and, if applicable, for the maintenance of such sign. All required information shall contrast with the background and be visible from the arterial highway and/or public park.

Subchapter C – Administrative remedies of the Department pursuant to section 26-260(d) of the Administrative Code.

§49-21 Department's discretionary power to revoke, suspend or refuse to renew registration and impose fines pursuant section 26-260(d) of the Administrative Code.

(a) The Department may revoke, suspend or refuse to renew the registration of an OAC on the grounds specified in section 26-260(d) of the Administrative Code. For the purposes of this section it shall be presumed that an OAC knew or should have known that such inventory was incomplete or inaccurate if the OAC or, if applicable, an affiliated OAC thereof, owns or has a contract for control of the sign, sign structure or sign location that is omitted from or inaccurately described in the sign inventory.

(b) Procedure for revocation of registration. Prior to revoking, suspending or refusing to renew the registration of an OAC or imposing fines or other penalties, the Department shall give such OAC notice and opportunity to be heard as follows:

(1) The Department shall serve notice on the OAC by regular mail, to the address and name provided in the most recent application for registration or renewal, listing the instances of

Rules and Regulations

liability by date, tribunal, section of law or rule found to have been violated, and title, caption, index number or other identifying indicator of the violation proceeding, if any.

(2) The notice shall advise the OAC of its right to submit papers in opposition to revocation, suspension of or refusal to renew the registration, and the deadline to do so, which shall not be less than 10 days after the date of mailing of such notice.

(3) Such notice, when the Department seeks to revoke or suspend the registration, also shall advise the OAC of its right to a hearing at the Office of Administrative Trials and Hearings ("OATH"), pursuant to the provisions of Chapter 13 of these Rules.

Subchapter D – Removal, Storage, and Disposal of Signs and Sign Structures.

§49-31 Applicability. The provisions of this subchapter shall apply to signs and sign structures removed by the Department or its authorized representatives pursuant to Administrative Code sections 26-127.3 and 26-262(d).

§49-32 Procedure.

(a) Where the signs and sign structures are physically removed, they shall be vouchered and maintained in a secure location.

(b) Within ten days after removal, the Department or an authorized representative designated by the Department shall send notice of such removal by regular mail to the owner of the sign and/or sign structure if the address and identity of such owner is reasonably ascertainable. If applicable, such notice shall include the place where the sign and/or sign structure may be claimed and the procedure for making a claim.

(c) The owner or other person lawfully entitled to possession of such property shall submit a claim for the release of such property to the Department or to an authorized representative designated by the Department. Such claim shall be accompanied by documentary proof establishing entitlement to such property.

(d) The costs of removal and storage of the sign shall be determined by the Department. Such costs shall be paid prior to release of the sign and/or sign structure unless the sign and/or sign structure is under the control of an OAC and the Department has served notice on such company and drawn upon the letter of credit or other security acceptable to the Department posted by such company, in accordance with section 26-127.3 of the Administrative Code.

(e) If, after consulting with the Department's enforcement unit, it is determined that fines or civil penalties have been imposed for a violation related to such sign or that an action or proceeding is pending in which such fines or civil penalties may be imposed, the sign and/or sign structure shall not be released without proof of payment of such fines and civil penalties or, if the action or proceeding is pending in which such fines or civil penalties may be imposed, proof that a letter of credit or other security acceptable to the Department

has been provided in an amount sufficient to guarantee such payment.

§49-33 Disposal of abandoned signs and/or sign structures. Signs and/or sign structures that are not claimed in accordance with the procedure set forth above within 30 days after removal shall be deemed abandoned and shall be sold at public auction or turned over to the Department of Sanitation in accordance with subdivision i of section 26-127.3 of the Administrative Code.

Subchapter E – Application for Sign Work Permit

§49-41 Application requirements.

(a) An application to erect, alter or install a sign and/or sign structure in an area that is subject to inclusion on the sign inventory as set forth in section 49-15 of this chapter that is larger than 200 square feet shall be accompanied by the following documentation:

(1) A detailed description and/or drawing of the proposed sign, including its size;

(2) A plot plan indicating the block and lot, zoning lot and exact location and size of the proposed sign and/or sign structure, as well as the location, size, and, if available, sign permit and OAC identification numbers for all other signs on the zoning lot, with their size in square feet;

(3) A statement indicating whether the proposed sign and/or sign structure will be within view of a public park of one-half acre or more or of an arterial highway.

(4) A statement indicating the distance in feet to each public park of one-half acre or more that is within 200 feet of the proposed sign, and to each road designated as an arterial highway, that is within 900 feet of such proposed sign. Distance to the public park or arterial highway shall be calculated as set forth in section 49-15(d)(1) of this chapter;

(5) A statement whether the proposed sign is to be "advertising," "accessory" to a business, or "non-commercial."

(6) For accessory signs, the following items shall be submitted with the application in addition to the other required items listed in this section:

a. The corporate name and D/B/A name of the use on the zoning lot that the proposed sign is to advertise and the name of the owner or principal of such business.

b. A written description of the existing or proposed business operation on the zoning lot, including the size of the business operation in square feet and average number of daily employees regularly on-site, signed and notarized by a principal or officer of such business;

c. A drawing and/or description of the proposed sign copy;

d. A complete lease signed by a principal or officer of the business, demonstrating the amount of space leased at the zoning lot by the business being advertised. If the business being advertised at the zoning lot owns the subject premises, a copy of the deed is to be provided;

e. A statement signed by the property owner indicating the parties with ownership, lease or creditor interest in the sign and sign structure;

Rules and Regulations

f. An approved alteration application and/or a certificate of occupancy or satisfactory historical evidence acceptable to the Borough Commissioner demonstrating that the specified business use to which the sign directs attention is permitted on the zoning lot;

g. A restrictive declaration, signed by a fee owner of the real property, that binds the owner and its successors to remove the sign and sign structure if at any time the use of the premises is changed, or an occupant of the premises ceases tenancy, such that the sign is no longer an accessory sign. The declaration shall further provide that if the sign is not removed, the Declarant consents to allow the City to enter onto the premises to remove the sign and sign structure and the Declarant agrees to reimburse the City for all actual costs associated with such removal. Proof of recording of the restrictive declaration must be submitted prior to approval of the sign work permit application; and

h. Financial statements detailing actual or projected income from the business at the zoning lot and demonstrating that no income or financial benefit shall be derived or expected from the sign.

(b) The work permit application shall be accompanied by a certification by a registered architect or licensed professional engineer that he or she has personal knowledge that the proposed sign and sign structure shall be in compliance with the zoning resolution and, if accessory, that the requirements of Paragraph (a)(6) of this section have been satisfied.

(c) No work permit shall be issued to erect a sign structure, unless a sign application has been approved to erect a sign thereon.

§49-42 Accessory sign permits.

(a) A sign permit for an accessory sign shall only be issued to a sign with non-changeable copy, except that the Borough Commissioner may, upon review, accept changeable copy for a digital sign, provided the name of the business to which the sign is directing attention appears prominently at all times on the sign, the changeable copy directs attention only to products sold at the premises, and the Department is provided with a direct access means to monitor the copy.

(b) The Borough Commissioner may request an inspection prior to issuing a permit for any accessory sign, to confirm that the sign will direct attention to a bona fide business on the zoning lot.

(c) No sign with a permit for non-changeable copy may be changed, including a change in its copy, without obtaining a new permit from the Department. A change in copy on a sign that was permitted for non-changeable copy may be considered an alteration of the sign for purposes of sections 27-147 and 27-177 of the Administrative Code.

§49-43 Advertising Signs. Absent evidence that revenue from the sign is clearly incidental to the revenue generated from the use on the zoning lot to which it directs attention, the following signs are deemed to be advertising signs for purposes of compliance with the Zoning Resolution:

(a) Signs that direct attention to a business on the zoning lot that is primarily operating a storage or warehouse use for business activities conducted off the zoning lot, and that storage or warehouse use occupies less than the full building on the zoning lot; or

(b) All signs, other than non-commercial, larger than 200 square feet, unless it is apparent from the copy and/or depictions on the sign that it is used to direct the attention of vehicular and pedestrian traffic to the business on the zoning lot.

CHAPTER 50

DISTRIBUTED ENERGY RESOURCE STANDARDS

§50-01 Requirements for the Installation of High-Pressure Natural Gas-Fired Microturbine Systems

(a) **General requirements.** All microturbine systems shall comply with the following general requirements:

(1) **Description.**

(i) The Microturbine System shall include one or more combustion-based turbine-driven electrical generators with 500 kW or less capacity, natural gas compressing equipment, heat recovery devices, electrical power distribution devices, gas vents or chimneys and associated appurtenances.

(ii) Microturbine systems shall utilize natural gas at an inlet pressure to the system of not greater than 3 psig, and shall boost the gas pressure to an inlet pressure to the combustion device of greater than 15 psig within the unit or room enclosure.

(iii) The total nominal electrical capacity at standardized operating conditions of all microturbine systems located within a single building shall not exceed 2,000 kW.

(2) **Listing or MEA approval.** For microturbines with external compressors, the compressor shall be MEA-approved and all components of the compressor and the microturbine shall be listed by a nationally recognized testing laboratory approved by the Commissioner. For microturbines with the compressor integrated with other elements into the unit, the integrated unit as well as each of its components shall be listed by a nationally recognized testing laboratory approved by the Commissioner.

(3) **Utility ruling.** The applicant shall consult the appropriate utility company regarding the characteristics of existing gas and electrical service to the site before installing the microturbine system. The applicant shall provide to the Department prior to plan approval either documentation from the utility company confirming that the electrical interconnection requirements have been preliminarily satisfied or an affidavit from the owner that there will be no interconnection with the electrical grid.

(4) **Filing and permit.** Plans for the complete microturbine system installation shall be approved by the New York City Department of Buildings and a work permit shall be obtained. A set of the approved plans shall be provided to the Fire Department.

Rules and Regulations

(5) **Installation.**

- (i) **Regulation.** Installation of microturbine systems shall be in accordance with all applicable requirements of the New York City Building Code, the New York City Electrical Code, and Reference Standards. NFPA 37 shall also apply, except where the Codes or these Rules are more restrictive. Such regulations include, but are not limited to the following: fuel gas piping, egress, fire protection, fire detection, electrical power, ventilation, and gas vent or chimney.
- (ii) **External compressor.** For microturbines with an external compressor, the following requirements shall be satisfied:
 - A. Gas connections between the compressor and the turbine shall be solid-welded; no threaded joints shall be permitted.
 - B. A flame arrestor shall be installed upstream of the gas compressor to prevent flame propagating to the natural gas fuel distribution lines.
 - C. The length of gas piping connecting the gas compressor with the combustion device, both of which shall be in the same room, shall not exceed 12 feet.
- (iii) **Annunciation.** All annunciations shall be provided locally and remotely to indicate any abnormal conditions in the system. The remote panel shall be located in a continuously supervised area on the premises.
- (iv) **Automatic gas shut-off.** Gas supply to the microturbine shall be provided with an automatic shut-off valve that is activated by a malfunction alarm from any component of the microturbine system.
- (v) **Remotely and manually controlled emergency gas shut-off.** A normally closed solenoid gas shut-off valve shall be located immediately after the branch connection providing dedicated service to the microturbine installation. The valve shall be manually controlled at the valve and remotely controlled both outside the door(s) to the microturbine room and at a supervised location. The gas shutoff valve and the controls shall each be clearly identified with signage indicating "emergency gas shut-off to microturbine."
- (vi) **Fuel shut-off valve diagram.** A diagram shall be conspicuously posted on any door or gate leading to a microturbine indicating the locations of all manual and automatic fuel shut-off valves.
- (vii) **Security.** The microturbine shall be provided with adequate protection from theft, tampering and unauthorized use. Access to microturbine systems shall be restricted by locked doors but shall be readily accessible for maintenance, repair and Fire Department access. Microturbines shall be adequately protected from vehicle impact.

- (viii) **Manufacturer's requirements.** All manufacturer's requirements and recommendations shall be satisfied.
 - (ix) **Signage.** Signage clearly stating "HIGH PRESSURE GAS" shall be posted on or in front of the microturbine or microturbine system, and on the outside of all doors accessing any microturbine room.
 - (x) **Existing buildings.** For installation of microturbines in existing buildings, a structural evaluation of the method of support of the microturbine system shall be performed by a licensed engineer. Vibration isolation shall be provided for the microturbine system as required to mitigate vibration impact on the building structure.
- (6) **Inspection.** Gas piping serving the microturbine shall be inspected by the Department. No self-certification of inspection shall be permitted. The inspection shall include a pipe integrity pressure test of all distribution piping. Installation and assembly of all system components shall be subject to a controlled inspection, in accordance with Section 27-132 of the New York City Building Code. Gas will be turned on only after successful completion of all testing.
- (7) **Fire Department permit.** A Fire Department permit is required to operate the equipment.
- (8) **Fire Department Certificate of Fitness.** A certificate of fitness ("C of F") holder, as authorized by the Fire Department, shall be required on the premises during regular business hours. The C of F holder shall be trained by the manufacturer or his authorized agent to shut down the equipment in an emergency.
- (9) **Service contract.** The owner shall obtain a service contract from the microturbine manufacturer or a service company qualified by the manufacturer upon approval of the microturbine installation, and shall maintain it during the life of the installation.
- (b) Permitted locations**
- (1) **Outdoors at grade, on a roof or on a roof setback, within an integral weatherproof or lightweight enclosure acceptable to the manufacturer,** subject to the following:
- (i) **Clearances.** All components of the microturbine system shall be located a minimum of 4 feet from a wall or parapet, 8 feet from any building opening, including any door, operable window or intake opening and 5 feet from any exhaust termination or chimney. All microturbine systems located at grade shall satisfy the following clearances:
 - A. 50 feet from any subway entrance, exit, vent or other opening;
 - B. 20 feet from any above-ground flammable or combustible liquid storage tank;
 - C. 10 feet from any lot line, except 4 feet from any lot line in and adjacent to a manufacturing district;
 - D. 5 feet from any vent or fill line of any flammable or combustible liquid storage tank;
 - E. 5 feet from any parked motor vehicle.

Rules and Regulations

- (ii) Enclosure. All microturbine system components shall be contained within integral weather-proof enclosures pursuant to the listing of the device. The unit enclosure or the lightweight constructed enclosure shall be provided with a gas detection system with an alarm that annunciates in a supervised location. Equipment not directly associated with the microturbine system shall not be permitted in the same enclosure.

(2) Within a dedicated Mechanical Equipment Penthouse classified as Occupancy Group D-2, and subject to the following:

- (i) Enclosure. The mechanical equipment penthouse shall be enclosed within 2-hour fire-resistance rated walls.
- (ii) Fire suppression. The equipment room shall be fully sprinklered or provided with an equivalent fire suppression system acceptable to the Commissioner.
- (iii) Mechanical ventilation. Mechanical ventilation shall be provided for the mechanical equipment penthouse at a rate sufficient to dissipate sensible heat released from the microturbine system in accordance with the manufacturer's recommendations, at a rate adequate to dilute the microturbine system rated flow rate of fuel gas below 25 percent of the lower flammability limit (LFL) of the fuel gas, or at an exhaust and make-up air rate of 80 times the maximum leakage rate of natural gas from the high-pressure system within the room at standard temperature and pressure based on the rated capacity of the gas compressor, whichever is greater. The ventilation rate shall not be less than required to maintain the ambient room temperature within the manufacturer's recommendations but shall not exceed 104 degrees Fahrenheit. Proper distribution of exhaust and make-up air must be provided to prevent pockets of increased gas concentration, including exhaust points high in the room to address the lighter-than-air properties of natural gas. Mechanical ventilation shall operate continuously.
- (iv) Gas detection and alarm. The mechanical equipment penthouse shall be provided with a gas detection system with an alarm that annunciates in a supervised location. The gas detection system shall also trip the microturbine.
- (v) Lighting. The mechanical equipment penthouse shall be provided with adequate lighting in accordance with the New York City Building Code.
- (vi) Other equipment. Equipment not directly associated with the microturbine system, including but not limited to gas meters, shall not be permitted within the mechanical equipment penthouse.
- (vii) Storage. No combustible materials shall be stored in the mechanical equipment penthouse.

(3) Within a dedicated room in a building, subject to the following:

- (i) Capacity. The total installed rated capacity of the microturbine system in the room shall not exceed 1,000 kW.
 - (ii) Enclosure. The microturbine room shall be enclosed within 2-hour fire-resistance rated walls.
 - (iii) Fire suppression. The equipment room shall be fully sprinklered or provided with an equivalent fire suppression system acceptable to the Commissioner.
 - (iv) Mechanical ventilation. Mechanical ventilation shall be provided for the microturbine room at a rate sufficient to dissipate sensible heat released from the microturbine system in accordance with the manufacturer's recommendations, at a rate adequate to dilute the microturbine system rated flow rate of fuel gas below 25 percent of the lower flammability limit (LFL) of the fuel gas, or at an exhaust and make-up air rate of 80 times the maximum leakage rate of natural gas from the high-pressure system within the room at standard temperature and pressure based on the rated capacity of the gas compressor, whichever is greater. The ventilation rate shall not be less than required to maintain the ambient room temperature within manufacturer's recommendations but not to exceed 104 degrees Fahrenheit. Proper distribution of exhaust and make-up air must be provided to prevent pockets of increased gas concentration, including exhaust points high in the room, to address the lighter-than-air properties of natural gas. Mechanical ventilation shall operate continuously.
 - (v) Gas detection and alarm. The microturbine room shall be provided with a gas detection system with an alarm that annunciates in a supervised location. The gas detection system shall also trip the microturbine.
 - (vi) Lighting. The microturbine room shall be provided with adequate lighting in accordance with the New York City Building Code.
 - (vii) Other equipment. Equipment not directly associated with the microturbine system, including but not limited to gas meters, shall not be permitted within the microturbine room.
 - (viii) Storage. No combustible materials shall be stored in the microturbine room.
- ### **(4) Within a boiler or other mechanical equipment room of a building,** subject to the following:
- (i) Capacity. The total installed rated capacity of the microturbine system in this room shall not exceed 500 kW.
 - (ii) Enclosure. The mechanical equipment room shall be enclosed within 2-hour fire-resistance rated walls.
 - (iii) Fire suppression. The mechanical equipment room shall be fully sprinklered or provided with an equivalent fire suppression system acceptable to the Commissioner.
 - (iv) Mechanical ventilation. Mechanical ventilation shall be provided for the mechanical equipment room at the rate sufficient to dissipate sensible heat released from all gas-burning equipment located within the

Rules and Regulations

mechanical equipment room in accordance with the microturbine manufacturer's recommendations, at a rate adequate to dilute the microturbine system rated flow rate of fuel gas below 25 percent of the lower flammability limit (LFL) of the fuel gas, or at an exhaust and make-up air rate of 80 times the maximum leakage rate of natural gas from the high-pressure system within the room at standard temperature and pressure based on the rated capacity of the gas compressor, whichever is greater. The ventilation rate shall not be less than required to maintain the ambient room temperature within the manufacturer's recommendations but shall not exceed 104 degrees Fahrenheit. Proper distribution of exhaust and make-up air must be provided to prevent pockets of increased gas concentration, including exhaust points high in the room, to address the lighter-than-air properties of natural gas. Mechanical ventilation shall operate continuously.

- (v) Gas detection and alarm. The mechanical equipment room shall be provided with a gas detection system with an alarm that annunciates in a supervised location. The gas detection system shall also trip the microturbine.
- (vi) Lighting. The mechanical equipment room shall be provided with adequate lighting in accordance with the New York City Building Code.
- (vii) Gas meters shall not be permitted within the mechanical equipment room.
- (viii) Storage. No combustible materials, including fuels, shall be stored in the mechanical equipment room.

CHAPTER 51 DORMITORIES

§51-01 Classification of Student Dormitory

(a) Applicability. Student dormitory is classified under the Zoning Resolution of the City of New York as a Use Group 3, community facility use. The Zoning Resolution allows residences of all kinds, including residences for students, under a Use Group 2 classification. This rule sets forth the criteria the Department shall use to designate a Class A building or part of a building as a Use Group 3 student dormitory. An owner that seeks to classify a rooming unit as a dormitory shall be subject to the provisions set forth in 1 RCNY 15-04(e).

(b) Definition. A student dormitory is a building or part of a building that is (1) operated by, or on behalf of, institution(s) that provide full-time day instruction and a course of study that may be pursued in fulfillment of the requirements of Sections 3204, 3205 and 3210 of the New York State Education Law, or post-secondary institution(s) authorized to grant a degree by the Regents of the University of the State of New York; (2) to house students enrolled at such institution(s). A student dormitory shall not be a single dwelling unit.

(c) Required documentation. No permit shall be issued to create a student dormitory unless the following documentation has been submitted to the Department:

(1) Proof of ownership or control.

a. Copies of documents demonstrating that the owner of the building or part of the building for which such permit is sought is an educational institution that provides a course of study that meets the requirements of subdivision (b) of this section, or

b. Copies of a lease of the building or part of the building for a minimum ten year term by an educational institution that meets the requirements of subdivision (b) of this section, or

c. Copies of documents evidencing (i) the establishment of a non-profit entity, all of whose members, directors, trustees, or other individuals upon whom is conferred the management of the entity, are representatives of participating educational institutions that meet the requirements of subdivision (b) of this section to provide dormitory housing for students of such participating educational institutions; and (ii) ownership or control of the building or part of the building by such non-profit entity for such purpose in the form of a deed or lease for a minimum ten-year term.

(2) Restrictive Declaration. Proof of recording of a restrictive declaration executed by Owner of the real property and any other party who holds an enforceable recorded interest that could result in such holder obtaining possession of the building or part of the building designated as a student dormitory. The agreement shall be binding upon all such parties' heirs, legal representatives, successors and assigns. The Declaration shall be in a form acceptable to the Commissioner and shall include the following terms:

a. The facility shall only be used as a student dormitory, as defined in this chapter, or other Use Group 3 use.

b. Under no circumstances shall the units in a student dormitory be offered for sale pursuant to a cooperative or condominium plan.

c. Owner agrees to forego defenses to the enforcement of the provisions of this section.

d. Owner agrees to prominently display the name(s) of the school(s) operating the student dormitory on the exterior of building.

(d) Term of Certificate of Occupancy. Where the student dormitory is not owned by an educational institution, but rather is leased, no certificate of occupancy shall be issued to the building for a term that exceeds the duration of the lease.

(e) Effect on other codes. The designation of a building or a part of a building as a student dormitory shall not by itself be determinative as to the occupancy, construction, or multiple dwelling classifications as determined pursuant to the Building Code, Housing Maintenance Code or Multiple Dwelling Law.

(f) If any clause, sentence, paragraph, subdivision, section, or part of this rule shall be adjudged by any court of competent jurisdiction to be invalid, such judgment shall not affect, impair or invalidate the remainder thereof, but shall be confined in its operation to the clause, sentence, paragraph, subdivision, section, or

Rules and Regulations

part thereof directly involved in the controversy in which such judgment shall have been rendered.

CHAPTER 52 NOTIFICATION TO THE DEPARTMENT OF COMMENCEMENT OF WORK PURSUANT TO AN EARTHWORK PERMIT

§52-01 Notification to the Department of Commencement of Work Pursuant to an Earthwork Permit

(a) Notification to the Department. Pursuant to Section 27-195 of the Administrative Code and subject to the exceptions set forth in subdivision (e) herein, no earthwork within the property line shall commence unless the permit holder notifies the Department as here prescribed at least twenty-four (24) but no more than forty-eight (48) hours prior to the commencement of such work. The notification shall state the date that such earthwork is to commence. Should the notification date fall on a weekend or an official holiday, the permit holder shall notify the Department on the last business day before the commencement date.

(b) Cancellation. In the event that the earthwork does not begin on the date provided in the notification to the Department, the permit holder shall notify the Department of its cancellation not more than twenty-four (24) hours prior to but no later than the date for which the earthwork was scheduled. Should the cancellation date fall on a weekend or an official holiday, the permit holder shall notify the Department on the next business day after the intended commencement date. The permit holder shall notify the Department of the new intended commencement date pursuant to the provisions of subdivision (a), above.

(c) Method of notification and cancellation. Such notification and cancellation shall be made by telephone or electronically.

(d) Stop work order. The Commissioner may issue a stop work order if there is a failure to provide notice as required in this section and if the work is found to violate any of the provisions of the Building Code, the Zoning Resolution or other applicable law, rule or regulation. Upon issuance of such stop work order, the work shall be stopped for a minimum of three (3) business days to enable the Department to take any other appropriate action to ensure that the earthwork is being performed in a safe manner. The earthwork shall not recommence until the stop work order has been lifted.

(e) Exceptions. The provisions of this section shall not apply to:

(1) Hand excavation work that extends five (5) feet or less below the grade existing at the time of earthwork commencement and is two (2) feet or more from an existing foundation. This exception shall not apply to

any hand excavation work performed anywhere in existing or demolished basements or cellars that adjoin existing foundations.

(2) Test pits for geotechnical observation that do not exceed ten (10) feet in length, width or diameter and that are excavated under the supervision of a licensed professional.

(3) Work on cemetery grounds for burials.

(4) Emergency work performed by the Department of Housing Preservation and Development (HPD) or other agency as directed by the Commissioner or work on unsafe buildings performed by HPD or other agency pursuant to a precept.

This space intentionally left blank.

Rules and Regulations

*CHAPTER 100

**Note: There is an intentional gap between Chapters 52 and 100.*

Subchapter A Administration

*§100-03 Fees payable to the Department of Buildings.

**Note: There is an intentional gap in numbering.*

The department shall charge the following fees:

| | | | | |
|---|--|-----------------|---------------------------------|------------------|
| Equipment inspection fee: <input type="checkbox"/> High-pressure boiler periodically inspected as provided by section 28-303.10 <input type="checkbox"/> Reinspection fee following a violation. | \$65 for each inspection, for each boiler. \$65 | | | |
| Acknowledgement. | \$2 each | | | |
| Certificate of occupancy. | \$5 per copy | | | |
| Certificate of pending violation: Multiple and private dwellings. | \$30 per copy | | | |
| Certified copy of license. | \$5 per copy | | | |
| Microfilming of applications for new buildings and alterations and associated documentation for certificates of occupancy, temporary certificates of occupancy and/or letters of completion, as required by rule of the commissioner. | \$35 | | | |
| Preparing only or preparing and certifying a copy of a record or document filed in the department, other than a plan, certificate of occupancy or certificate of pending violation. | \$8.00 for the first page and \$5.00 for each additional page or part thereof (a page consists of one face of a card or other record). | | | |
| Half-size print from microfilm of a plan thirty-six by forty-eight inches or less. | \$8.00 per copy | | \$5.00 per additional copy | |
| Half-size print from microfilm of a plan exceeding thirty-six by forty-eight inches. | \$16.00 per copy | | \$5.00 per additional copy | |
| Electrician's license. | Original \$310 | Renewal \$90 | Late Renewal \$310 + \$90 | Reissue \$310 |
| License examination fee: <input type="checkbox"/> Elevator agency director certificate of approval. <input type="checkbox"/> Elevator agency inspector certificate of approval. | \$350 \$350 | | | |

*§101-01 Definition of existing building.

**Note: There is an intentional gap in numbering.*

For the purposes of section 27-123.3 of the administrative code, the term "existing building" shall mean a building in existence prior to December 6, 1968 or a building constructed in accordance with the building laws and regulations in force prior to such date. For the purposes of section 27-123.1 of the administrative code, the term "existing building" shall mean a building in existence prior to the effective date of local law number 58 of 1987 (August 5, 1987). For the purposes of section 27-123.2 of the administrative code, the term "existing building" shall mean a building in existence prior to the effective date of local law number 10 of 1999 (March 24, 1999).

*§101-06 Special inspectors and special inspection agencies.

**Note: There is an intentional gap in numbering.*

(a) Definitions.

For the purposes of this chapter, the following terms shall have the following meanings:

(1) *Accreditation.* Evaluation of agencies, including testing and calibration laboratories, fabricators and inspection bodies, against internationally acceptable standards to demonstrate their performance capability. Such accreditation is required to be conducted by a nationally recognized accreditation agency accrediting to ASTM E329-07 international standard, the requirements of this rule, and approved by the department.

(2) *Approved Construction Documents.* For the purpose of this rule approved construction documents shall include any and all documents that set forth the location and entire nature and extent of the "work" proposed with sufficient clarity and detail to show that the

Rules and Regulations

proposed work conforms to the provisions of this code and other applicable laws and rules. Such documents shall include but not be limited to shop drawings, specifications, manufacturer's instructions and standards that have been accepted by the design professional of record or such other design professional retained by the owner for this purpose.

(3) *Certification*. Documented acknowledgment by a nationally recognized organization of a technician's competency to perform certain functions.

(4) *Commissioner*. The commissioner of buildings or his or her designee.

(5) *Department*. The department of buildings.

(6) *Initial acceptable qualifications*. With respect to supplemental special inspectors for which Appendix A of this rule requires a certification, such technician shall be deemed qualified without such certification provided that such individual has the underlying skills, education and training for which such certification would provide validation, and the relevant experience prescribed by Appendix A of this rule or by the certifying body.

(7) *Job*. A construction project that is the subject of one (1) or more department-issued permits.

(8) *Materials*. Materials, assemblies, appliances, equipment, devices, systems, products and methods of construction regulated in their use by this code or regulated in their use by the 1968 building code.

(9) *New York City Construction Codes*. The New York City Plumbing Code, the New York City Building Code, the New York City Mechanical Code, the New York City Fuel Gas Code, and Title 28, chapters 1 through 5 of the Administrative Code. Any reference to "this code" or "the code" shall be deemed a reference to the New York City Construction Codes as here defined.

(10) *Registered Design Professional*. A New York State licensed and registered architect (RA) or a New York State licensed and registered professional engineer (PE).

(11) *Registered Design Professional Of Record*. The registered design professional who prepared or supervised the preparation of applicable construction documents filed with the department.

(12) *Relevant Experience*. Direct participation and practice related to the underlying construction activities that are the subject of the special inspection where such participation has led to accumulation of knowledge and skill required for the proper execution of such inspection.

(13) *Special Inspection*. Inspection of selected materials, equipment, installation, methods of construction, fabrication, erection or placement of components and connections, to ensure compliance with the code.

(14) *Special Inspection Agency*. An agency employing one (1) or more persons who are special inspectors and that has met all requirements of this rule.

(15) *Special Inspector*. An individual employed by a special inspection agency, who has the required qualifications, set forth in this rule to perform or witness particular special inspections required by the code or by the rules of the department, including but not limited to a qualified registered design professional.

(16) *Supervise/Supervision*. With respect to a designated Primary Inspector or Inspection Supervisor as indicated in Appendix A, supervision shall mean oversight and responsible control by a registered design professional having the necessary qualifications and relevant experience to perform responsibilities associated with the special inspection. Such supervision shall include ensuring training and/or education necessary to qualify the special inspector for his or her duties, including continued training and education necessary to keep pace with developing technology. Field supervision shall include responsibility for determining competence of special inspectors for the work they are authorized to inspect and on-site monitoring of the special inspection activities at the job site to assure that the qualified special inspector is performing his or her duties when work requiring inspection is in progress. With respect to a Director of a Special Inspection Agency, supervision shall mean oversight and responsible control by a registered design professional who shall ensure that qualified inspectors are dispatched for special inspections, that such special inspectors properly document their activities, and that reports and logs are prepared in accordance with section 28-114.2 of the Administrative Code. Such supervision shall include ensuring training and/or education necessary to qualify the special inspector for his or her duties, including continued training and education necessary to keep pace with developing technology.

(17) *Technician*. An employee of the inspection or testing agency assigned to perform the actual operations of inspection or testing. See ASTM E 329-07, paragraph 3.1.17.

(18) *Work*. The construction activity including techniques, tests, materials and equipment that is subject to special inspection.

(b) Duties.

(1) *Availability and Compliance*. A special inspector and/or special inspection agency shall have responsibilities as set forth in chapter 17 of the New York City Building Code and elsewhere in the codes where special inspections are required. The responsibilities of the special inspector or special inspection agency at a special inspection shall include those tasks and standards set forth in chapter 17 of the code, the reference standards and elsewhere in the code, this rule or any rule of any agency in connection with the work that is the subject of such special inspection.

(2) *Obligation to Avoid Conflict of Interest*. A special inspector and/or a special inspection agency shall not

Rules and Regulations

engage in any activities that may conflict with their objective judgment and integrity, including but not limited to having a financial and/or other interest in the construction, installation, manufacture or maintenance of structures or components that they inspect.

(3) Approved Construction Documents. The special inspector and/or special inspection agency shall:

(i) Examine all approved construction documents that relate to the work that is the subject of the special inspections.

(ii) Confirm that the documents are sufficient to enable the proper performance of the special inspection.

(iii) Confirm that the documents are acceptable to the registered design professional of record or another design professional retained by the owner and who prepared the documents for the construction of the job. Acceptance shall be demonstrated in writing by the design professional on the documents.

(iv) Confirm that the work that is the subject of the special inspection is in compliance with all relevant approved construction documents and with chapter 17 of the code or elsewhere in the construction codes or their referenced standards.

(4) Documentation. A special inspection agency shall maintain records of special inspections on a job-by-job basis for at least six (6) years or for such period as the commissioner shall determine, and shall make such records available to the department upon request. Such records shall include field logs, test results, laboratory reports, notes, noted deficiencies and dates of cures of such deficiencies, photographs and such other information as may be appropriate to establish the sufficiency of the special inspection.

(i) The supervisor shall review special inspection progress reports and final reports for conformance with the approved plans, specifications and workmanship provisions of chapter 17 of the code or elsewhere in the construction codes or their referenced standards. Such supervision and control shall be evidenced by the supervisor's signature and seal upon any required statements, applications and/or reports.

(ii) The principal of the special inspection agency shall file with the department within ten (10) days of satisfactory completion of any special inspection, notice of such completion on the forms and in the manner required by the department.

(5) Obligation to Cooperate with Inquiries. All special inspectors and/or special inspection agencies shall cooperate in any investigation by the department, or other city or law enforcement agency, into the activities at any job site or fabricating/manufacturing facility for which they have been designated a special inspector or special inspection agency and shall provide prompt, accurate and complete responses to reasonable inquiries by the department and other appropriate agencies about the conduct of such business.

(6) Limitation of Duties. Activities as a special inspection agency are specifically limited to those special inspections for which the special inspection agency has been registered and for which it has satisfied the requirements set forth in this rule and chapter 17 of the code. No special inspector or special inspection agency shall conduct any special inspection that such inspector or inspection agency is not qualified or registered to perform in accordance with the requirements of this rule and chapter 17.

(7) Obligation to Comply with an Order of the Commissioner. All special inspectors and/or special inspection agencies shall comply with an order of the commissioner.

(8) Equipment and Tools. The special inspection agency shall possess and maintain tools and equipment required to perform the specific special inspection. Such tools and equipment shall be maintained and calibrated periodically in accordance with applicable nationally accepted standards governing that equipment or tool.

(9) Reporting. The special inspection agency shall report any discrepancies noted during the inspection to the contractor and when applicable to the superintendent of construction, as well as to the site safety coordinator or site safety manager, for correction. If the discrepancies are not corrected, the discrepancies shall be brought to the attention of the owner, and the registered design professional of record prior to the completion of that phase of the work. The special inspector/special inspection agency shall immediately report conditions noted as hazardous to life, safety or health, to the attention of the commissioner.

(c) Registration of Special Inspection Agencies.

(1) Effective Date. On or after the effective date of this rule, all agencies including single person agencies performing special inspections must comply with the requirements of this section. All such agencies performing special inspections must be registered with the department as special inspection agencies by January 1, 2009 unless otherwise extended by the commissioner, as provided in paragraph (c)(9) of this rule.

(2) Form and Manner of Registration. An application for registration shall be submitted in a form and manner determined by the commissioner, including electronically, and shall provide such information as the commissioner may require. Such registration shall be deemed an acknowledgement by the special inspection agency of its obligations hereunder.

(3) Qualifications. Special inspection agencies shall be required to demonstrate accreditation by International Accreditation Service, Inc. or an equivalent accreditation agency accrediting to the standards set forth in this rule and ASTM E329-07 or a federal agency. Accrediting agencies, other than federal agencies must

Rules and Regulations

be members of an internationally recognized cooperation of laboratory and inspection accreditation bodies subject to a mutual recognition agreement. Agencies must insure that the special inspectors employed by the agency meet the qualification requirements set forth in Appendix A of this rule and perform special inspections only within the area of expertise for which such special inspector is qualified. A Professional Engineer who is listed in Appendix A as requiring qualification in civil, structural, mechanical, electrical, fire protection, geotechnical or such other designation shall have had the education, training and experience, including having passed the Principles and Practice of Engineering examination offered by the National Council of Examiners for Engineering and Surveying (NCEES) in the specific discipline or having obtained a bachelors degree in the specific field, that has led to an accumulation of knowledge and skill required for the Professional Engineer to hold himself/herself out as a professional practicing in that field.

(4) Insurance. A special inspection agency must have the following insurance coverage:

(i) Professional liability/errors and omissions insurance policy, for the minimum amount of five hundred thousand dollars (\$500,000.00), occurrence based, for the term of the registration,

(ii) General liability insurance policy for the minimum amount of one million dollars (\$1,000,000.00) and

(iii) Insurance required by the provisions of the New York State disability benefits law and other applicable provisions of the workers' compensation law.

(5) Agency Structure. The special inspection agency shall have a full-time director who is a registered design professional in responsible charge and all special inspections shall be performed under his or her direct supervision. The director shall not be retained by any other agency that provides special inspection or testing services. The director shall possess relevant experience in the inspection and testing industry and hold a management position in the agency. The agency structure shall comply with all relevant New York State and Federal laws. Notwithstanding anything to the contrary set forth in this paragraph, an agency that is limited to conducting fuel-oil storage and fuel-oil piping inspections (BC1704.16), fire alarm tests, sprinkler systems (BC1704.21), standpipe systems (BC1704.22), emergency power systems or site storm drainage disposal and detention (BC1704.20) may have a director who satisfies the requirements of inspection supervisor for such tests and inspections as set forth in Appendix A of this rule.

(6) Small Building Exception. Notwithstanding anything to the contrary set forth in the provisions of this rule and its appendix, with respect to jobs in

connection with the construction or alteration of Occupancy Group R-3 buildings, 3 stories or less in height, a registered design professional with relevant experience shall be qualified to perform special inspections other than inspections involving soils investigations, pier and pile installation, underpinning of structures, and protection of the sides of excavations greater than 10 feet in depth.

(7) Audits. The operations of special inspectors and special inspection agencies shall be subject to audit by the department at any time. Audits may examine applications for registration as well as the performance and documentation of special inspections. Audits may also be conducted upon receipt of complaints or evidence of falsification, negligence or incompetence.

(8) Interim Status and Application Deadlines. An agency employing special inspector(s) with initial acceptable qualifications shall be entitled until July 1, 2010 to perform those special inspections for which it is qualified, subject to the following requirements:

(i) The agency must certify compliance with this rule.

(ii) The agency must diligently pursue accreditation as a special inspection agency pursuant to the provisions of section (c)(3) of this rule.

(iii) Notwithstanding anything to the contrary set forth in this rule and Appendix A, an individual who satisfies all requirements set forth in Appendix A to qualify as a special inspector except for the required certification shall be deemed a special inspector until July 1, 2009 provided that such individual meets the initial acceptable qualifications. In order to continue as a special inspector beyond July 1, 2009, such individual shall obtain the certification required in Appendix A.

(iv) The agency shall certify such initial acceptable qualifications on such form as the department may require and shall file such certification with the department prior to performing any special inspections after the effective date of this rule

(9) Additional Powers of the Commissioner. Notwithstanding anything to the contrary set forth in the provisions of this rule, the commissioner may upon a determination of good cause extend the interim status of qualifications for any specific special inspection agency to a date beyond July 1, 2010 but in no event later than July 1, 2011.

(i) In the event the agency has failed by January 1, 2010 to receive the accreditation required by section (c)(8)(i) of this rule, the agency may apply to the commissioner who may, upon the showing of good cause by the agency, grant an extension of time and allow the continuance of the interim status of such agency, but in no event later than January 1, 2011.

(ii) The requirements and standards prescribed in this rule shall be subject to variation in specific cases by the commissioner, or by the Board of Standards and

Rules and Regulations

Appeals, under and pursuant to the provisions of paragraph two of subdivision (b) of section six hundred forty-five and section six hundred sixty-six of the New York City Charter, as amended.

(10) Registration Term. An initial registration issued under this rule is valid until July 1, 2010 unless otherwise extended by the commissioner in accordance with section (c)(9) of this rule. A renewal or initial registration issued after July 1, 2010 is valid for three years from the date of issuance.

(11) Registration Fees. The department shall charge the following registration fees:

- (i) A one (1) year initial fee of \$35;
- (ii) A triennial renewal fee of \$35; and
- (iii) A later renewal surcharge of \$35.

(12) Renewals. A renewal application shall be submitted between thirty (30) and sixty (60) days prior to the expiration date of the registration and shall be accompanied by proof that the agency has, during the one (1) year period immediately preceding renewal, maintained all certifications/accreditations and other requirements set forth in this rule and its Appendix.

(i) Renewal shall be precluded where there has been a finding by the commissioner that any special inspection or test conducted by the special inspector or special inspection agency has not been performed in accordance with the requirements set forth in the code, applicable reference standards or the rules of the department, or where there has been a finding by the commissioner of fraud or misrepresentation on any document or report submitted to the department by the special inspector or special inspection agency.

(ii) No special inspector or special inspection agency shall perform an inspection or test with an expired or lapsed registration.

(d) Disciplinary Actions.

(1) Suspension or revocation of registration and refusal to accept filings. The commissioner may, in accordance with the rules of the department, suspend or revoke a special inspection agency registration, with or without the imposition of penalties, for violation of any provision of the code or the rules of the department, or any other applicable laws or rules. The commissioner may refuse to accept any application or other document submitted pursuant to or in satisfaction of any requirement of this rule or of chapter 17 of the code or any rule or regulation of any agency that bears the signature of any special inspector who has been found, after an opportunity to be heard to have knowingly or negligently made a false statement or to have knowingly or negligently falsified or allowed to be falsified any certificate, form, signed statement, application, report or certification of the correction of a violation required under the provisions of this chapter, the code or any rule or regulation of any agency.

(2) Stop work and Suspension of Permits. Upon any suspension or revocation of registration pursuant to paragraph (d)(1) of this rule, unless replaced by another registered special inspector and/or special inspection agency within five (5) business days of such suspension or revocation, all jobs on which the special inspector and/or special inspection agency whose registration was suspended or revoked is designated, shall be stopped and the permits shall be suspended until such time as a duly registered special inspector and/or special inspection agency is designated to re-inspect such tests or such inspections performed by the disciplined special inspection agency, or until such permits expire.

(e) Obligations of Others. Nothing in this rule is intended to alter or diminish any obligation otherwise imposed by law, including but not limited to the obligation of an owner, construction manager, general contractor, contractor, materialman, architect, engineer, site safety manager, land surveyor, superintendent of construction or other party involved in a construction project to engage in sound engineering, design, and construction practices, and to act in a reasonable and responsible manner to maintain a safe construction site.

This space intentionally left blank.

APPENDIX A

| Special Inspection Category | 2008 Code Section | Qualifications ^{1,2} | | |
|--|----------------------------------|---|--|---|
| | | Primary Inspector or Inspection Supervisor | Supplemental Inspector (Alternative 1) - under direct supervision of Inspection Supervisor | Supplemental Inspector (Alternative 2) - under direct supervision of Inspection Supervisor |
| 1. General Building Construction | | | | |
| Wall Panels, Curtain Walls, and Veneers | BC 1704.10 | <ul style="list-style-type: none"> RA or PE – Civil or Structural Engineering; and 1 Year relevant experience | <ul style="list-style-type: none"> Bachelor's degree in Architecture or Civil Engineering or Structural Engineering; and 2 years relevant experience | <ul style="list-style-type: none"> Technician with 3 years relevant experience |
| Exterior Insulation Finish Systems (EIFS) | BC 1704.12 | <ul style="list-style-type: none"> PE or RA; and 1 year relevant experience | N/A | <ul style="list-style-type: none"> Technician with 2 years relevant experience |
| Chimneys | BC 1704.24 | <ul style="list-style-type: none"> PE or RA; and 1 year relevant experience | <ul style="list-style-type: none"> Bachelor's degree in Architecture or Engineering; and 2 years relevant experience | <ul style="list-style-type: none"> Technician with ICC Certification as a Residential or Commercial Mechanical Inspector; and 5 years relevant experience |
| Flood Hazard Mitigation | BC G105 | <ul style="list-style-type: none"> PE or RA; and 1 year relevant experience | N/A | N/A |
| Photoluminescent Exit Path Markings | 1 RCNY 1026-01 (formerly RS 6-1) | <ul style="list-style-type: none"> PE or RA; and relevant experience | N/A | <ul style="list-style-type: none"> Technician with relevant experience |
| Small Building Special Inspections (Group R-3, 3 stories or less in height) ³ | | <ul style="list-style-type: none"> PE or RA; and relevant experience | N/A | <ul style="list-style-type: none"> Technician with relevant experience |

Rules and Regulations

| Special Inspection Category | 2008 Code Section | Qualifications ^{1,2} | | |
|---|--------------------------|--|---|---|
| | | Primary Inspector or Inspection Supervisor | Supplemental Inspector (Alternative 1) - under direct supervision of Inspection Supervisor | Supplemental Inspector (Alternative 2) - under direct supervision of Inspection Supervisor |
| 2. Fire Protection Systems & Fire-Resistant Construction | | | | |
| Sprayed Fire-resistant Materials | BC 1704.11 | <ul style="list-style-type: none"> • PE or RA; and • 1 year relevant experience | <ul style="list-style-type: none"> • Bachelor's degree in Architecture or Engineering; and (a or b) <ul style="list-style-type: none"> a. 1 year relevant experience; or b. ICC Certification as a Spray-applied Fireproofing Special Inspector | <ul style="list-style-type: none"> • Technician with ICC Certification as a Spray-applied Fireproofing Special Inspector; and • 3 years relevant experience |
| Smoke Control Systems | BC 1704.14 | <ul style="list-style-type: none"> • PE or RA; and • 1 year relevant experience (mechanical and/or fire protection) | N/A | <ul style="list-style-type: none"> • Technician with NEBB Air Balancer Certification; and • 3 years relevant experience |
| Standpipe Systems and Sprinkler Systems | BC 1704.21 BC 1704.22 | <ul style="list-style-type: none"> • PE – Mechanical Engineering; and • 1 year relevant experience OR <ul style="list-style-type: none"> • NYC Licensed Class A or Class B Master Fire Suppression Piping Contractor License; and • Independent of installer | <ul style="list-style-type: none"> • Bachelor's degree in Mechanical Engineering; and • 3 years relevant experience | Technician with NICET Level II Certification in Fire Protection – Inspection and Testing of Water-based Systems |
| Firestop, Draftstop, and Fireblock Systems | BC 1704.25 | <ul style="list-style-type: none"> • PE or RA; and • 1 year relevant experience | <ul style="list-style-type: none"> • Bachelor's degree in Architecture or Engineering; and • 2 years relevant experience | <ul style="list-style-type: none"> • Technician with 3 years relevant experience |

Rules and Regulations

| Special Inspection Category | 2008 Code Section | Qualifications ^{1,2} | | |
|---|-------------------|--|---|---|
| | | Primary Inspector or Inspection Supervisor | Supplemental Inspector (Alternative 1) - under direct supervision of Inspection Supervisor | Supplemental Inspector (Alternative 2) - under direct supervision of Inspection Supervisor |
| Fire Alarm Test (When FDNY inspection not required) | | <ul style="list-style-type: none"> • PE – Electrical or Fire Protection; and • 1 year relevant experience <p>OR</p> <ul style="list-style-type: none"> • Licensed electrician independent of installer; and • 3 years relevant experience | N/A | Technician with NICET Level II Certification in Fire Alarm Systems. |
| Emergency Power Systems (Generators) | | <ul style="list-style-type: none"> • PE – Mechanical, Electrical, or Fire Protection; and • 1 year relevant experience <p>OR</p> <ul style="list-style-type: none"> • Licensed electrician independent of installer; and • 3 years relevant experience | <ul style="list-style-type: none"> • Technician with 5 years relevant experience | N/A |
| 3. Plumbing & Mechanical Systems | | | | |
| Mechanical Systems | BC 1704.15 | <ul style="list-style-type: none"> • PE or RA; and <ul style="list-style-type: none"> ○ 1 year relevant experience; or ○ ICC Certification as a Residential or Commercial Mechanical Inspector | <ul style="list-style-type: none"> • Bachelor's Degree in Architecture, or Engineering; and • 2 years relevant experience; and • ICC Certification as a Residential or Commercial Mechanical Inspector | <ul style="list-style-type: none"> • Technician with ICC Certification as a Residential or Commercial Mechanical Inspector; and • 3 years relevant experience |

Rules and Regulations

| Special Inspection Category | 2008 Code Section | Qualifications ^{1,2} | | |
|---|-------------------|---|---|---|
| | | Primary Inspector or Inspection Supervisor | Supplemental Inspector (Alternative 1) - under direct supervision of Inspection Supervisor | Supplemental Inspector (Alternative 2) - under direct supervision of Inspection Supervisor |
| Fuel-Oil Storage and Fuel-Oil Piping Systems | BC 1704.16 | <ul style="list-style-type: none"> • PE or RA; and • 1 year relevant experience OR <ul style="list-style-type: none"> • Licensed New York City Class A and B Oil Burner Equipment Installer; and • 1 year experience in the inspection of heating systems, Fuel burning-Fuel storage systems. | <ul style="list-style-type: none"> • Bachelors degree in Architecture, or Mechanical, Marine or Civil Engineering; and • 3 years relevant experience | <ul style="list-style-type: none"> • Technician with ICC Certification as a Residential or Commercial Mechanical Inspector; and • 5 years relevant experience |
| Site Storm Drainage Disposal and Detention Facilities | BC 1704.20 | <ul style="list-style-type: none"> • PE or RA; and • 1 year relevant experience OR <ul style="list-style-type: none"> • NYC Licensed Master Plumber; and • 3 years relevant experience | <ul style="list-style-type: none"> • Bachelor's Degree in Architecture, Civil or Mechanical Engineering; and • 3 years relevant experience | N/A |
| Heating Systems | BC 1704.23 | <ul style="list-style-type: none"> • PE or RA – Civil or Mechanical Engineering; and • 1 year relevant experience | <ul style="list-style-type: none"> • Bachelor's Degree in Architecture, or Civil or Mechanical Engineering; and • 3 years relevant experience; and • ICC Certification as a Residential or Commercial Mechanical Inspector | <ul style="list-style-type: none"> • Technician with ICC Certification as a Residential or Commercial Mechanical Inspector; and • 5 years relevant experience |

Rules and Regulations

| Special Inspection Category | 2008 Code Section | Qualifications ^{1,2} | | |
|--|---|--|---|--|
| | | Primary Inspector or Inspection Supervisor | Supplemental Inspector (Alternative 1) - under direct supervision of Inspection Supervisor | Supplemental Inspector (Alternative 2) - under direct supervision of Inspection Supervisor |
| 4. Structural Materials & Construction Operations | | | | |
| Welding: Steel High pressure Steam Piping High pressure Gas Piping Aluminum (2 RNCY 25 – BSA RULE) | BC 1704.3.1 BC 1704.17 BC 1704.18 BC 1704.26 | <ul style="list-style-type: none"> • PE or RA; and • AWS Certified Welding Inspector (AWS-CWI); OR <ul style="list-style-type: none"> • PE or RA; and • ICC Certification as a Structural Welding Inspector (ICC-SWI); and • 1 year relevant experience | <ul style="list-style-type: none"> • AWS Certified Welding Inspector (AWS-CWI) OR <ul style="list-style-type: none"> • ICC Certification as a Structural Welding Inspector (ICC-SWI) • 3 years relevant experience | <ul style="list-style-type: none"> • AWS Certified Associate Welding Inspector (AWS-CAWI) <p>Note: AWS-CAWI only permitted to inspect when an AWS-CWI or ICC-SWI is on site supervising</p> |
| Structural Steel – Erection & High-Strength Bolting Note: Inspection can also be performed by agency approved to inspect welding | BC 1704.3.2, BC 1704.3.3 | <ul style="list-style-type: none"> • PE – Civil/Structural; and • ICC Certification as a Structural Steel and Bolting Inspector; and • 1 year relevant experience | N/A | <ul style="list-style-type: none"> • Technician with ICC Certification as a Structural Steel and Bolting Inspector; and • 3 years relevant experience |
| Structural Cold-formed Steel | BC 1704.3.2.4 | <ul style="list-style-type: none"> • PE or RA; and • 1 year relevant experience | <ul style="list-style-type: none"> • Bachelor's degree in engineering or architecture; and • 2 years relevant experience | <ul style="list-style-type: none"> • Technician with ICC Certification as a Structural Steel and Bolting Special Inspector; and • 3 years relevant experience |
| Concrete – Cast-in-place & Precast Note: Licensed concrete testing lab to perform sampling and testing of cylinders | BC 1704.4 | <ul style="list-style-type: none"> • PE or RA; and • 1 year relevant experience | <ul style="list-style-type: none"> • ACI Certification as Concrete Construction Special Inspector (ACI-CCSI) OR <ul style="list-style-type: none"> • ICC Certification as Concrete Special Inspector (ICC-CSI) | <ul style="list-style-type: none"> • ACI Certification as an Associate Concrete Construction Special Inspector (ACI-ACCSI) <p>Note: ACI-ACCSI only permitted to perform inspection under on-site supervision by PE, RA, ACI-CCSI, or ICC-CSI</p> |

Rules and Regulations

| Special Inspection Category | 2008 Code Section | Qualifications ^{1,2} | | |
|--|---------------------------------------|--|---|--|
| | | Primary Inspector or Inspection Supervisor | Supplemental Inspector (Alternative 1) - under direct supervision of Inspection Supervisor | Supplemental Inspector (Alternative 2) - under direct supervision of Inspection Supervisor |
| Prestressed Concrete | BC 1704.4 | <ul style="list-style-type: none"> • PE – Civil/Structural; and • 1 year relevant experience | <ul style="list-style-type: none"> • Bachelor's degree in engineering; and • ICC Certification as Prestressed Concrete Special Inspector; and • 1 year relevant experience | <ul style="list-style-type: none"> • ICC Certification as Prestressed Concrete Special Inspector; and • 3 years relevant experience |
| Masonry | BC 1704.5 | <ul style="list-style-type: none"> • PE or RA; and • 1 year relevant experience | <ul style="list-style-type: none"> • Bachelor's degree in engineering or architecture; and • ICC Certification as a Structural Masonry Special Inspector; and • 1 year relevant experience | <ul style="list-style-type: none"> • ICC Certification as a Structural Masonry Special Inspector; and • 2 years relevant experience |
| Wood construction – Prefabricated wood I-joists and metal-plate-connected wood trusses | BC 1704.6 | <ul style="list-style-type: none"> • PE or RA; and • 1 year relevant experience | N/A | <ul style="list-style-type: none"> • ICC Certification as a Commercial or Residential Building Inspector; and • 2 years relevant experience |
| Soils - Site Preparation | BC 1704.7.1, BC 1704.7.2, BC 1704.7.3 | <ul style="list-style-type: none"> • PE – Geotechnical, Civil, or Structural; and • 1 year relevant experience | N/A | N/A |
| Soils- Fill Placement, In-place Density | BC 1704.7.1, BC 1704.7.2, BC 1704.7.3 | <ul style="list-style-type: none"> • PE – Geotechnical, Civil, or Structural; and • 1 year relevant experience | <ul style="list-style-type: none"> • Bachelor's degree in Geotechnical, Civil, or Structural engineering; and • 1 year relevant experience | <ul style="list-style-type: none"> • Technician with NICET Level I Geotechnical Certification; and • 2 years relevant experience <p>OR</p> <ul style="list-style-type: none"> • Technician with ICC Certification Soils Special Inspector • 1 year relevant experience |

Rules and Regulations

| Special Inspection Category | 2008 Code Section | Qualifications ^{1,2} | | |
|--|--------------------------|--|--|---|
| | | Primary Inspector or Inspection Supervisor | Supplemental Inspector (Alternative 1) - under direct supervision of Inspection Supervisor | Supplemental Inspector (Alternative 2) - under direct supervision of Inspection Supervisor |
| Soils Investigations | BC 1704.7.4 | <ul style="list-style-type: none"> • PE – Geotechnical, Civil, or Structural; and • 1 year relevant experience | <ul style="list-style-type: none"> • Bachelor's degree in Geotechnical, Civil, or Structural engineering; and • 1 year relevant experience | <ul style="list-style-type: none"> • Technician with NICET Level II Geotechnical Certification; and • Must take and pass Soils classification sections of NICET certification |
| Pile Foundations and Drilled Pier Installation | BC 1704.8 BC 1808.2.2 | <ul style="list-style-type: none"> • PE – Geotechnical, Civil, or Structural; and • 1 year relevant experience | <ul style="list-style-type: none"> • Bachelor's degree in Geotechnical, Civil, or Structural engineering; and • 3 years relevant experience <p>Note: Supplemental Inspector only permitted to inspect when multiple driving rigs are used on the same site and Primary Inspector is on site supervising</p> | <ul style="list-style-type: none"> • Technician with NICET Level III Geotechnical Certification <p>Note: Supplemental Inspector only permitted to inspect when multiple driving rigs are used on the same site and Primary Inspector is on site supervising</p> |
| Pier Foundations | BC 1704.9 | <ul style="list-style-type: none"> • PE – Geotechnical, Civil, or Structural; and • 1 year relevant experience | <ul style="list-style-type: none"> • Bachelor's degree in Geotechnical, Civil or Structural; and • 3 years relevant experience | N/A |
| Underpinning | BC 1704.9.1 | <ul style="list-style-type: none"> • PE – Geotechnical, Civil, or Structural; and • 1 year relevant experience | <ul style="list-style-type: none"> • Bachelor's degree in Geotechnical, Civil or Structural; and • 3 years relevant experience | N/A |
| Structural safety - Stability, and Mechanical Demolition | BC 1704.19 | <ul style="list-style-type: none"> • PE – Civil/Structural; and • 1 year relevant experience | <ul style="list-style-type: none"> • Bachelor's Degree in Civil or Structural Engineering; and • 3 years relevant experience | N/A |

Rules and Regulations

| Special Inspection Category | 2008 Code Section | Qualifications ^{1,2} | | |
|---|----------------------|--|---|---|
| | | Primary Inspector or Inspection Supervisor | Supplemental Inspector (Alternative 1) - under direct supervision of Inspection Supervisor | Supplemental Inspector (Alternative 2) - under direct supervision of Inspection Supervisor |
| Excavation - Sheeting, Shoring, and Bracing | BC 1704.19, 3304.4.1 | <ul style="list-style-type: none"> • PE – Geotechnical, Civil, or Structural; and • 1 year relevant experience | <ul style="list-style-type: none"> • Bachelor's degree in Geotechnical, Civil or Structural; and • 3 years relevant experience | <ul style="list-style-type: none"> • Technician with 5 years relevant experience |
| Seismic Isolation Systems | BC 1707.8 | <ul style="list-style-type: none"> • PE; and • 2 years relevant experience | <ul style="list-style-type: none"> • Bachelor's degree in Geotechnical, Civil, or Structural engineering; and • 5 years relevant experience | <ul style="list-style-type: none"> • N/A |

Notes:

- Abbreviations in the qualifications descriptions:
 - ACI – American Concrete Institute
 - AWS – American Welding Society
 - ICC – International Code Council
 - NEBB – National Environmental Balancing Bureau
 - NICET – National Institute for Certification in Engineering Technologies
 - PE – A New York State Licensed and Registered Professional Engineer
 - RA – A New York State Licensed and Registered Architect
- Bachelor's Degrees must be from an accredited institution or equivalent
- Small Building Inspections - For Group R-3 buildings, 3 stories or less in height, all special inspections may be performed by a qualified PE or RA or a qualified person under their direct supervision without the need for certification by the department, with the exception of the special inspection of the following operations:
 - Soils Investigations
 - Pier and Pile installation
 - Underpinning of structures
 - Protection of the sides of excavations greater than 10 feet in depth

Rules and Regulations

§101-07 Inspections and approved agencies.

(a) **Definitions.** For the purposes of this section, all terms used herein shall have the same meanings as set forth in the building code. In addition, the following terms shall have the following meanings:

(1) *Approved construction documents.* Any and all documents that set forth the location and entire nature and extent of the work proposed with sufficient clarity and detail to show that the proposed work conforms to the provisions of the building code and other applicable laws and rules. Such documents shall include shop drawings, specifications, manufacturer's instructions and standards that have been accepted by the design professional of record or such other design professional retained by the owner for this purpose.

(2) *Approved boiler inspection agency.* An agency employing qualified boiler inspectors, as defined below.

(3) *Approved inspection agency.* An agency that is approved by the department as qualified to inspect at regular intervals the material that is to be or is listed and labeled, to verify that the labeled material is representative of the material tested. Such term shall include, when approved pursuant to department rules, a third party testing or certification agency, evaluation agency, testing laboratory, testing service or other entity concerned with product evaluation.

(4) *Approved progress inspection agency.* An agency that is approved by the department as qualified to perform one or more of the progress inspections required by section BC 109 of the building code.

(5) *Approved testing agency.* An agency that is approved by the department as qualified to test and evaluate the performance of one or more of the materials regulated in its use by the building code. Such term shall include, when approved pursuant to department rules, a third party testing or certification agency, evaluation agency, testing laboratory, testing service or other entity concerned with product evaluation. Such term shall also include a licensed concrete testing laboratory.

(6) *Certificate of compliance.* A certificate stating that materials meet specified standards or that work was done in compliance with approved construction documents and other applicable provisions of law.

(7) *Qualified boiler inspector.* An inspector who has been issued a certificate of competence by the State Department of Labor and who is employed by an authorized insurance company, a high pressure boiler operating engineer licensed pursuant to the provisions of the New York City Administrative Code, a class A or class B oil burning equipment installer licensed pursuant to the provisions of such Code, a master plumber licensed pursuant to the provisions of such Code, or a journeyman plumber acting under the direct and continuing supervision of a master plumber

licensed pursuant to the provisions of such Code. For inspection of boilers at properties owned or managed by the Department of Education, such term shall include an individual who has passed the National Board Commission examination and who has 5 years relevant experience, as defined below, approved by the department.

(8) *Qualified exterior wall inspector.* A New York State licensed civil or structural engineer with 1 year relevant experience or a New York State registered architect with 1 year relevant experience.

(9) *Relevant experience.* Direct participation and practice related to the underlying construction activities that are the subject of the special or other inspection where such participation has led to accumulation of knowledge and skill required for the proper execution of the special or other inspection.

(10) *Supervision.* Oversight and responsible control by a registered design professional having the necessary qualifications and relevant experience to effectively perform responsibilities associated with the inspection being supervised. Such supervision shall include ensuring the inspector's training/education through whatever arrangements are necessary to the inspector's duties and shall also include plans for continued training to keep pace with developing technology. Field supervision shall include responsibility for determining competence of special inspectors for the work they are authorized to inspect and monitoring the inspection activities at the jobsite to assure that the qualified inspector is performing his or her duties when work requiring inspection is in progress. The supervisor shall review inspection progress reports and final reports for conformance with the approved plans, specifications and workmanship provisions of the building code. Such supervision and control shall be evidenced by the supervisor's signature and seal upon any required statements, applications and/or reports.

(11) *Technician.* An employee of the inspection or testing agency assigned to perform the actual operations of inspection or testing. See ASTM E329-07, paragraph 3.1.17.

(b) **General requirements for approved agencies.**

(1) **Availability and compliance.** An approved agency shall have responsibilities set forth in this rule and in the building code. Such agency shall employ experienced personnel qualified to conduct, supervise and evaluate the tests or inspections that it undertakes.

(2) **Duties.** The approved agency shall:

(i) Examine all relevant documents, including approved construction documents and/or manufacturers' instructions that define and describe requirements in connection with the test or inspection to be performed.

(ii) Confirm that the documents are sufficient to enable the proper performance of the test or inspection.

Rules and Regulations

(iii) Confirm that any relevant approved construction documents are acceptable to the registered design professional of record or another design professional retained by the owner for the purpose of accepting shop drawings and that the manufacturers' instructions are current. Acceptance shall be demonstrated in writing on the drawing by the registered design professional.

(iv) Confirm through the test or inspection that the installation and materials are in compliance with all relevant documents, reference standards and the building code.

(3) Documentation. An approved agency shall maintain records of inspections and tests for at least 6 years or for such shorter period as the commissioner shall determine and shall make such records available to the department upon request. Such records shall include field logs, test results, laboratory reports, notes, photographs and such other information as may be necessary or appropriate to establish the sufficiency of the inspection. The principal of the approved agency shall furnish to the department upon request such records of any inspection or test, in the manner required by the department.

(4) Obligation to cooperate with inquiries. All approved agencies shall cooperate with any investigation by the department, or other city or law enforcement agency, into the activities at any job site or fabricating/manufacturing/testing facility for which such agencies have undertaken any inspections or tests and shall provide prompt, accurate and complete responses to reasonable inquiries by the department and other such city or law enforcement agencies about the conduct of such activities.

(5) Limitation of duties. An approved agency shall not engage in any activity for which it has not been registered, licensed or accredited. An inspector or technician employed by an approved agency shall not perform inspections or tests beyond the area of expertise for which he or she is qualified in accordance with the standards set by the department, the accrediting agency, if applicable, and the agency supervisor.

(6) Obligation to comply with an order of the commissioner. All approved agencies shall comply with an order of the commissioner.

(7) Insurance. Every approved agency shall maintain the following insurance coverage:

(i) A general liability insurance policy for the amount of one million dollars;

(ii) Insurance required by the provisions of the New York State Worker's Compensation and Disability Laws; and

(iii) For progress inspection agencies and qualified exterior wall inspectors only, in addition to the requirements of (i) and (ii) above, a Professional Liability/Errors and Omissions insurance policy, occurrence based, for the term of the registration or accreditation.

(8) Agency structure. An approved agency's structure shall comply with all applicable New York State and Federal laws.

(9) Audits. The operations of approved agencies shall be subject to audit at any time. Audits may examine applications for registration or accreditation as well as the performance and documentation of inspections and tests. Audits may also be conducted upon receipt of complaints or evidence of falsification, negligence or incompetence.

(c) Qualifications of approved agencies.

(1) Except as otherwise provided in subdivision (d) of this section, on or after the effective date of this section, all approved agencies, including single person approved agencies, shall comply with the requirements of this section and Title 28-114 of the New York City Administrative Code and shall meet the qualifications set forth herein.

(2) Testing and inspection agencies.

(i) A testing and/or inspection agency shall be deemed an approved testing and/or approved inspection agency for testing and/or inspecting materials and listing and labeling materials to specified standards in accordance with the building code and its referenced standards where such agency has achieved accreditation for such testing and/or inspections from International Accreditation Service, Inc. or an equivalent accrediting agency accrediting to the standards set forth in ASTM Designation: E 329-07 or a federal agency. Accrediting agencies, other than federal agencies, must be members of an internationally recognized cooperation of laboratory and inspection accreditation bodies subject to a mutual recognition agreement.

(ii) An approved testing and/or approved inspection agency shall have in responsible charge a director who shall be qualified by education and relevant experience to undertake the tests or inspections performed. Qualification may be based on the standards set forth in ASTM E329-07. The director shall personally supervise the testing and/or inspection of materials for compliance with prescribed nationally recognized standards. Concrete testing laboratories shall follow the provisions of subdivision (c)(6) of this section.

(iii) Technicians shall be qualified by education and relevant experience to perform all tests or inspections they may be required to conduct under the supervision of the director. Qualification may be based on the standards set forth in ASTM E329-07.

(iv) An approved testing agency shall furnish to the department such proof of qualifications of all personnel and information regarding the equipment used to perform tests as the department may from time to time request, and any other such information that the commissioner deems appropriate in assessing the competency of the agency's operations.

(v) All approved testing and approved inspection agency inspection and test reports shall be retained in a

Rules and Regulations

form acceptable to the department and shall bear the name of the approved agency, its accreditation, license or department acceptance identification information where applicable, the name of the director who supervised the inspection or test, the names of all personnel who performed the inspection or test, and the names of all witnesses to such inspection or test.

(3) Progress inspection agencies.

(i) Registered design professionals with relevant experience shall be deemed approved progress inspection agencies, without further requirement of registration or accreditation, for the purpose of conducting the progress inspections required by section BC 109 of the building code. Such progress inspections shall include the following:

- (A) Preliminary. See section 28-116.2.1 of the New York City Administrative Code and section 109.2 of the building code.
- (B) Footing & foundation. See section 109.3.1 of the building code.
- (C) Lowest floor elevation. See section 109.3.2 of the building code.
- (D) Frame inspection. See section 109.3.3 of the building code.
- (E) Energy Code Compliance Inspections. See section 109.3.5 of the building code.
- (F) Fire-resistant rated construction. See section 109.3.1 of the building code.
- (G) Final. See section 28-116.2.4.2 of the New York City Administrative Code and section 109.5 of the building code.
- (H) Public assembly emergency lighting. See section 1006 and 1024 of the building code and section 28-116.2.2 of the Administrative Code.

(ii) A progress inspection agency shall conduct required progress inspections, provided such inspections are conducted by a registered design professional with relevant experience or a person under such design professional's direct supervision.

(iii) A progress inspection agency's performance of a progress inspection shall include verification that any special inspections that were required to have been conducted prior to the progress inspection have been documented as completed.

(4) Elevator inspection agencies.

(i) Notwithstanding anything to the contrary set forth herein, elevator inspection companies, including their agency directors and agency inspectors that currently hold or hereafter secure a Certificate of Approval from the department issued pursuant to Chapter 11 of Title 1 of the Rules of the City of New York shall be deemed approved elevator inspection agencies without further requirement of registration or accreditation, for the purpose of conducting the periodic elevator inspections and tests required by section 28-304.6 of the Administrative Code.

(ii) Written or oral tests required by 1 RCNY 11-01(2)(ii) shall require familiarity with the standards set forth in section 3001.2 and appendix K of the building code.

(iii) Tests and inspections performed after the effective date of this section shall be performed in compliance with reference standards set forth in section 3012.1 and appendix K of the building code, provided that for the period from January 1, 2008 through September 15, 2008, inspections and tests need not be witnessed by another approved elevator inspection agency.

(iv) Effective January 1, 2009, periodic elevator inspections and tests required by section 28-304.6.1 of the Administrative Code shall be performed in compliance with the following requirements:

(A) The test must be performed by an approved elevator inspection agency and witnessed by an approved elevator inspection agency not affiliated with the agency performing the test.

(B) The approved elevator inspection agency responsible for performing the test shall designate skilled elevator trade personnel in its employment to perform the test under the direct supervision of a director who holds a Certificate of Approval from the department issued pursuant to the 1968 Building Code and 1 RCNY 11-01. Such designation by the director shall be in writing and shall indicate the director's endorsement of the qualification of the personnel designated to conduct the test.

(C) The approved elevator inspection agency responsible for witnessing the test shall designate to witness such test an inspector in its employment who holds a Certificate of Approval from the department issued pursuant to the 1968 Building Code and 1 RCNY 11-01.

(D) The witnessing inspector shall affix the inspection date and his or her agency's Certificate of Approval number to the inspection certificate at the site. The witnessing inspector and the director of the witnessing agency shall further sign and indicate that agency's Certificate of Approval number in the test report.

(5) Boiler inspection agencies.

(i) Notwithstanding anything to the contrary set forth herein, a qualified boiler inspector shall be deemed an approved boiler inspection agency, without further requirement of registration or accreditation, for the purpose of conducting the periodic inspections required by section 28-303.2 of the Administrative Code. Such approved boiler inspection agencies may complete required periodic boiler inspections for the period from January 1, 2008 through December 31, 2008 in compliance with the requirements of the 1968 Building Code and 1 RCNY 2-01. Notwithstanding the above, reports of periodic boiler inspections for the period January 1, 2008 to December 31, 2008 shall be

Rules and Regulations

accompanied by a certification that identified defects have been corrected. The inspection report must be submitted to the department prior to December 31, 2008.

(ii) Effective January 1, 2009, periodic boiler inspections required by section 28-303.2 of the Administrative Code shall be performed in compliance with the following requirements:

(A) Low pressure boiler annual inspection reports shall be submitted for each calendar year on such forms and in such manner as required by the department. The report shall include:

((a)) An inspection report for each boiler identifying the inspector or inspection agency;

((b)) The owner's annual statement completed in compliance with section 28-303.6 of the Administrative Code; and

((c)) A certification by the owner that identified defects have been corrected. The report must be filed within 45 days of the inspection but in no event later than December 31st of each calendar year. Any required part of the report not filed within 45 days of the inspection and on or before December 31st shall be deemed late and shall subject the owner to penalties as provided in Administrative Code sections 28-201.2.2 and 28-202.1.

(B) A low pressure boiler annual inspection must be conducted between November 16th of the preceding calendar year through November 15th of the calendar year for which the report is being submitted at a date that follows the preceding annual inspection by 6 months or more. The inspector must verify that a department-issued boiler number is affixed to the boiler and such number must be used in all correspondence between the inspector and the department. If an inspection reveals any dangerous condition in a boiler that threatens life or safety and that requires an immediate shut down of the boiler, the inspector must immediately notify the boiler division at the department of the condition via fax or email at the number or address provided on the department's website, <http://www.nyc.gov/buildings>.

(C) Low pressure boiler annual inspection reports not filed within 12 months from the date of the inspection will be deemed expired. Expired inspection reports will not be accepted by the department to satisfy the annual inspection report filing requirement as prescribed by section 28-303 of the Administrative Code and this section.

(6) Concrete testing laboratories.

(i) Except as provided in subdivision (d) of this rule, a concrete testing laboratory shall be deemed an approved agency and a licensed concrete testing laboratory pursuant to the provisions of Article 406 of Title 28 of the Administrative Code for purposes of testing and inspecting concrete-related construction activities in accordance with the building code and its

referenced standards where such laboratory has achieved accreditation from AASHTO Accreditation Program or an equivalent accrediting agency accrediting to the standards set forth in ASTM Designations: C1077, C1093 and E 329-07 or a federal agency. Accrediting agencies, other than federal agencies, must be members of an internationally recognized cooperation of laboratory and inspection accreditation bodies subject to a mutual recognition agreement.

(ii) A licensed concrete testing laboratory shall have in responsible charge a director who shall be qualified by education and relevant experience to undertake the tests or inspections performed. Qualification may be based on the standards set forth in ASTM C1077, C1093 and E 329-07. The director shall personally supervise the inspection and tests for compliance with prescribed nationally recognized standards. The director shall be a registered design professional.

(iii) Technicians shall be qualified by education and relevant experience to perform all tests or inspections they may be required to conduct under the supervision of the director. Field technicians shall be certified as ACI Field Testing Technician – Grade I, or other equivalent certification acceptable to the commissioner.

(iv) Laboratory technicians shall be certified as ACI Concrete Testing Laboratory Technician – Level 1, or other equivalent certification acceptable to the commissioner. Qualification may be based on the standards set forth in ASTM C1077, C1093 and E 329-07.

(v) The concrete testing laboratory shall furnish to the department such proof of qualifications of all personnel and information regarding the equipment used to perform tests as the department may from time to time request, and any other such information that the commissioner deems appropriate in assessing the competency of the laboratory's operations.

(vi) All concrete testing laboratory inspection and test reports shall be presented in a form acceptable to the department and shall bear the name of the laboratory or service and its accreditation and department-issued license number where applicable, the name of the director who supervised the inspection or test, the names of all personnel who performed the inspection or test, and the names of all witnesses. Reports shall be signed and sealed by the director who supervised the inspection or test

(7) Exterior wall inspections.

(i) Examination of a building's exterior walls and appurtenances thereof pursuant to section 28-302 of the Administrative Code shall be performed by or under the direct supervision of a qualified exterior wall inspector.

(ii) A qualified exterior wall inspector shall maintain records of inspections and tests for at least 6 years and shall make such records available to the department upon request.

Rules and Regulations

(iii) A qualified exterior wall inspector shall maintain insurance coverage as set forth in subdivision (b)(7) above.

(iv) Except as modified by the building code and this section, the provisions of 1 RCNY 32-02 shall apply.

(d) Interim status and application deadlines. An approved agency that is required to achieve accreditation shall be entitled, until July 1, 2010, to perform those inspections and tests for which it is seeking accreditation, provided that the following are true:

(1) The agency is diligently pursuing accreditation by the required accreditation services or an equivalent accreditation agency approved by the department.

(2) The agency is in good standing with the department and is licensed and/or accepted by the department pursuant to the laws in effect prior to July 1, 2008 to perform specific tests and inspections. Such agencies shall be limited to the performance of those tests for which they are under such prior law specifically licensed or accepted to perform.

(3) On or before July 1, 2010, an agency with interim status as an approved agency shall achieve accreditation as set forth in this rule. In the event the approved agency has failed by July 1, 2010 to achieve such accreditation, the agency may apply to the commissioner who may, upon a showing of good cause, grant an extension of time to achieve accreditation and allow the continuance of the interim status.

(e) Suspension or revocation of approved agency status.

(1) In accordance with department rules, the commissioner may suspend or revoke an approved agency's approval, with or without the imposition of penalties, for violation of any provision of Title 28 of the Administrative Code or the building code or the rules of the department, or any other applicable law or rule. The commissioner may refuse to accept any application or other document submitted pursuant to or in satisfaction of any requirement of law or rule that bears the signature of any approved agency or director that has been found, after notice and an opportunity to be heard, to have knowingly or negligently made a false statement or to have knowingly or negligently falsified or allowed to be falsified any certificate, form, signed statement, application, report or certification of the correction of a violation required under the provisions of Title 28 of the Administrative Code or the building code or any rule of any agency.

(2) Invalidation of tests and inspections upon suspension or revocation of approved agency status. Upon any suspension or revocation of approved agency approval pursuant to subdivision (e), the owner of a building at which such approved agency was required or scheduled to perform special, progress or periodic inspections shall immediately designate another approved agency to re-do such tests or inspections

performed by the disciplined agency. Any periodic inspections performed by a disciplined agency shall be rejected in the current cycle of such inspections and any owner of a building requiring such periodic inspection shall, upon notice of such disciplinary action, retain another approved agency to perform the periodic inspection.

(f) Obligations of others. Nothing in this section is intended to alter or diminish any obligation otherwise imposed by law on others, including but not limited to, the owner, construction manager, general contractor, contractor, materialman, architect, engineer, site safety manager, land surveyor, superintendent of construction or other party involved in a construction project, to engage in sound engineering, design, and construction practices, and to act in a reasonable and responsible manner to maintain a safe construction site.

***§101-10 Final Inspection and Sign-Off prior to letter of completion.**

**Note: There is an intentional gap in numbering.*

(a) **Final Inspection.** Where permitted work does not require the issuance of a certificate of occupancy and where the final inspection is performed by an approved agency, the final inspection shall be performed after all work authorized by the permit is completed, but in no event later than one (1) year from the date of the expiration of the last valid permit.

(b) **Inspection Report.** A final inspection report complying with the requirements of section 28-116.2.4.2 of the Administrative Code shall be filed within thirty (30) days of the date of the final inspection that enables the inspector to attest that the work is substantially compliant with the approved construction documents, the building code, and other applicable laws and rules.

(c) **Applicability.** The requirements in this section shall apply to all final inspections performed after July 1, 2008, regardless of when the underlying permit was issued.

Subchapter B Enforcement

§102-01 Violation reclassification and certification of correction.

(a) Pursuant to section 28-204.1 of the Administrative Code, any person who shall violate or fail to comply with any provision or provisions of law enforced by the Department or with any order issued pursuant thereto shall be liable for a civil penalty that may be recovered in a proceeding before the Environmental Control Board ("ECB"). Such proceeding shall be commenced by service of a notice of violation ("NOV") returnable before the board. Such notice of violation may be issued by employees of the Department or of other city agencies designated by the Commissioner and may be served by such employees or by a licensed process server.

(b) Classification of violations. For purposes of classifying violations pursuant to section 28-201.2 of the Administrative Code, the following terms shall have the following meanings:

(1) IMMEDIATELY HAZARDOUS VIOLATION.

Immediately hazardous violations are those specified as such by the New York City Construction Codes, or those

Rules and Regulations

where the violating condition poses a threat that severely affects life, health, safety, property, the public interest, or a significant number of persons so as to warrant immediate corrective action, or, with respect to outdoor advertising, those where the violation and penalty are necessary as an economic disincentive to the continuation or the repetition of the violating condition. Immediately hazardous violations shall be denominated as Class 1 violations.

(2) MAJOR VIOLATION. Major violations are those specified as such by the New York City Construction Codes or those where the violating condition affects life, health, safety, property, or the public interest but does not require immediate corrective action, or, with respect to outdoor advertising, those where the violation and penalty are appropriate as an economic disincentive to the continuation or the repetition of the violating condition. Major violations shall be denominated as Class 2 violations.

(3) LESSER VIOLATION. Lesser violations are those where the violating condition has a lesser effect than an immediately hazardous (Class 1) or major violation (Class 2) on life, health, safety, property, or the public interest. Lesser violations shall be denominated as Class 3 violations.

(c) Correction and certification of correction.

(1) Each NOV issued by the Commissioner shall contain an order of the Commissioner directing the respondent to correct the condition constituting the violation and to file a certification with the Department that the condition has been corrected

(2) The following violation cannot be certified as corrected prior to a hearing before ECB. The respondent must appear at the hearing prior to the submission of the certification to the Department:

(i) A violation for filing a false certification;

(3) The required certification shall be completed on the form issued with the NOV or obtained from the Department in accordance with the instructions contained therein.

(4) The respondent must appear at the ECB hearing for all violating conditions unless those charges are cured or a pre-hearing stipulation is offered, timely accepted by the respondent, and approved in writing by ECB. Where more than one violation of law is listed on the same NOV, the respondent may submit a single certification covering one or all of the violating conditions.

(5) The certification shall be signed by one with personal knowledge of the correction of the violating condition and notarized by a notary public or commissioner of deeds.

(6) The certification shall be accompanied by true and legible copies of any and all documentary proof of compliance.

(7) The completed certification must be returned to the Department at the address provided on the City's website, NYC.gov.

(8) For violations classified as Class 3 or for those Class 2 violations eligible for a cure, respondents may avoid a hearing by submitting a certification of correction acceptable to and

received by the Department no later than forty days from the date of the Commissioner's order to correct set forth in the NOV. For violations classified as Class 1, a certification acceptable to the Department must be received by the Department forthwith.

(9) Failure to submit an acceptable certification for all violating conditions indicated on the NOV on a Department of Buildings form within the time period prescribed in paragraph (8) of this subdivision shall require the respondent to appear at a hearing at ECB on the date indicated on the NOV. If no certificate of correction is received within the time period prescribed in paragraph (8) of this subdivision, the respondent is also subject to issuance of a violation for failure to certify correction and the imposition of civil penalties as defined in Title 28-202.1.

(d) Mitigated and zero penalties. Mitigated or zero penalties are available in the following circumstances under the following conditions.

(1) Cure.¹ An eligible violation may be cured by correction before the first scheduled hearing date at ECB. All violations that are designated as Class 3 violations are eligible for cure. Some, but not all, types of violations that are designated as Class 2 violations are eligible for cure. Those types of Class 2 violations that are eligible for cure will be indicated within the ECB Buildings Penalty Schedule found in Chapter 31 of Title 15 of the Rules of the City of New York ("ECB Buildings Penalty Schedule"). In order to cure, a certificate of correction acceptable to the Department must be filed at the Department within forty days from the date of the Commissioner's order to correct set forth in the NOV. A cure constitutes an admission of the violation; dispenses with the need for a hearing at ECB; constitutes a predicate violation for subsequent violations; and, consistent with the provisions of Section 28-204.2, and with the provisions of the ECB Buildings Penalty Schedule, results in a zero penalty. A violation that has been charged as an Aggravated II violation is never eligible for a cure, even if there is a "Yes" in the "Cure" column in the ECB Buildings Penalty Schedule for that violation description.

¹*Section 28-204.2 of the Administrative Code provides for a zero penalty for Lesser violations that are corrected within the prescribed, or cure, period. For purposes of this rule, certain Major violations will also be treated as eligible for cure to the extent that section 28-202.1 of the Administrative Code specifies no minimum penalty for such violations.*

(2) Stipulation. An eligible violation may be subject to stipulation where the Commissioner offers to the respondent a stipulation prior to or at a hearing to extend the time for compliance upon such terms and conditions as the Commissioner prescribes. Violations that are eligible for stipulation are indicated as such on the ECB Buildings Penalty Schedule. The respondent must admit the violation subject to stipulation and agree to correct it and file an acceptable certification of correction with the Department. The stipulation may be signed and submitted to ECB either before the first scheduled hearing date at ECB or else on the first scheduled hearing date but prior to any actual hearing on that date, in which case it is considered a **pre-hearing**

Rules and Regulations

stipulation, or may be entered into at the first ECB hearing in which case it is considered a **hearing stipulation**. A reduced penalty will be imposed in connection with a pre-hearing stipulation in an amount indicated for the charge in question in the ECB Buildings Penalty Schedule. Specifically, the penalty imposed for that violation will be half of the penalty amount (rounded to the nearest dollar) of the penalty amount that would otherwise have been imposed at a hearing for that particular violation. In connection with a stipulation entered into at a hearing, a hearing penalty will be imposed in an amount indicated for the charge in question in the ECB Buildings Penalty Schedule. A stipulation, whether a pre-hearing stipulation or a hearing stipulation, gives the respondent seventy-five days from the first scheduled hearing date within which to correct the violation and file a certificate of correction, failing which any reduced penalty that may have been imposed in connection with a pre-hearing stipulation will be adjusted to the standard hearing penalty set forth in the ECB Buildings Penalty Schedule. A stipulation is effective only if it is approved by ECB. A pre-hearing stipulation dispenses with the need for a hearing at ECB. No stipulation shall take effect unless, in the case of a pre-hearing stipulation, it is offered by the Department prior to the first scheduled hearing date, signed by respondent prior to the first scheduled hearing date and approved by ECB in writing, or unless, in the case of a hearing stipulation, it is offered by the Department at the hearing, accepted by the respondent at that hearing, and is approved in writing by ECB. A violation that has been charged as an Aggravated II violation is never eligible for a stipulation, even if there is a "Yes" in the "Stipulation" column in the ECB Buildings Penalty Schedule for that violation description.

(3) Mitigation. An eligible violation may be subject to mitigation where the respondent proves at the hearing that the condition was corrected prior to the first scheduled hearing date at ECB. Violations that are eligible for mitigation are indicated as such on the ECB Buildings Penalty Schedule. A penalty is imposed on mitigations in accordance with the ECB Buildings Penalty Schedule. If a mitigated penalty is imposed, that penalty will be half of the penalty amount of the penalty amount that would otherwise have been imposed at a hearing for that particular violation. An acceptable certificate of correction must thereafter be filed at the Department. A violation that has been charged as an Aggravated II violation is never eligible for mitigation, even if there is a "Yes" in the "Mitigation" column in the ECB Buildings Penalty Schedule for that violation description.

(e) Certificate of correction review procedures.

(1) The Department shall review all certificates and accompanying documentation to determine their acceptability.

(2) The Department shall notify the respondent if the certification is accepted or rejected and, if rejected, the reasons for the rejection and the documents necessary to correct the problem.

(3) Corrected certifications must be received by the Department no later than the close of business forty days from

the date of the Commissioner's order to correct set forth in the NOV.

(f) Aggravated penalties. Aggravated penalties shall be imposed in accordance with the ECB Buildings Penalty Schedule and with the following provisions. Notice of aggravated penalties shall either be set forth in the NOV or otherwise provided to the respondent prior to the date of the first scheduled hearing at ECB.

(1) Aggravated penalties of the first order. Aggravated penalties of the first order ("Agg. I") shall be imposed when evidence establishes the same condition or the same charge under the New York City Construction Codes or the predecessor charge under the laws in effect prior to July 1, 2008 in a prior enforcement action against the same owner or responsible party during the previous three years.

(2) Aggravated penalties of the second order. Aggravated penalties of the second order ("Agg. II") shall be imposed in the following instances:

(i) When the respondent or defendant is found in violation of any law or rule enforced by the Department where the violation of law is accompanied by or results in a fatality or serious injury or where the violating condition affects a significant number of people; or

(ii) Where the respondent or defendant refuses to give the Department requested information necessary to determine the condition of a building or site; or

(iii) Where the respondent or defendant has a history of non-compliance with laws or rules enforced by the Department at one or more locations, including but not limited to a pattern of unreasonable delays in correcting violations, a pattern of failing to obey Stop Work Orders, filing false documents, or multiple defaults.

(iv) For purposes of this section, "in violation" shall mean to be adjudged in violation of any law or rule enforced by the Department following a hearing, to admit the charge, or to sign a stipulation agreement either at or before a hearing before any administrative or judicial tribunal. Failure to appear at a hearing leading to entry of a default order or judgment shall also be deemed a finding "in violation."

(g) Additional Daily and Monthly Penalties. Additional daily penalties may be imposed in connection with certain continuing and uncorrected Class 1 violations. Additional monthly penalties may be imposed in connection with certain continuing and uncorrected Class 2 violations. If the Department seeks such penalties in connection with a particular Class 1 or Class 2 charge, that will be indicated on the NOV. Such daily or monthly penalties, if applicable, are in addition to the set, flat-amount penalty that also is indicated in the ECB Buildings Penalty Schedule as applicable to the type of violation in question taking into account the classification level and Aggravated level of the particular violation. Imposition of such additional daily and monthly penalties is authorized pursuant to Section 28-202.1 of the New York City Administrative Code.

(1) Accrual of Daily Penalties. Daily penalties, if applicable, will accrue at the rate of \$1,000 per day for a total of forty-five days running from the date of the Commissioner's order to

Rules and Regulations

correct set forth in the NOV, unless the violating condition is proved by the respondent at the hearing to have been corrected prior to the end of that forty-five day period, in which case the daily penalties will accrue for every day up to the date of that proved correction.

(2) **Accrual of Monthly Penalties.** Monthly penalties, if applicable, accrue at the rate of \$250 per month for a total of one month running from the date of the Commissioner's order to correct set forth in the NOV, unless the violating condition is proved by the respondent at the hearing to have been corrected prior to the end of a month period.

(h) **Applicability.** On and after July 1, 2008 any work performed without a required permit will be presumed subject to enforcement under the New York City Construction Codes. Thus, the option afforded by 28-101.4 to use *[the] either the 1968 Building Code or the New York City Construction Codes applies only to work for which an application is filed with the Department. If and when the work is the subject of an application to legalize, the option will be available once again.

**As enacted but probably not intended.*

(i) **Legal References.** The legal references referred to in the table below that reflects the classification of violations include the following:

(1) Title 28 of the New York City (NYC) Administrative Code. References to Title 28 of the NYC Administrative Code begin with "28-" (for example, "28-201.1"). The citation "28-Misc." refers to provisions of Title 28 that are not specifically designated elsewhere in the table.

(2) Title 27 of the NYC Administrative Code (also known as the "1968 Building Code"). References to title 27 of the NYC Administrative Code begin with "27-" (for example, "27-371"). The citation "27-Misc." refers to provisions of Title 27 that are not specifically designated elsewhere in the table.

(3) The "New York City Construction Codes," which consist of:

- The New York City plumbing code (PC)
- The New York City building code (BC)
- The New York City mechanical code (MC)
- The New York City fuel gas code (FGC).

References to these New York City Construction Codes are designated by the various abbreviations set out above (for example, "BC3010.1"). The citations "BC-Misc.," "PC-Misc.," "MC-Misc." and "FGC-Misc." refer to provisions of the New York City building, plumbing, mechanical or fuel gas codes that are not specifically designated elsewhere in the table.

(4) **Appendices to the New York City Construction Codes.** The New York City Construction Codes include all enacted appendices. Administrative Code §28-102.6. References to Appendices are cited by using the abbreviation for the particular Construction Code followed by the applicable Appendix letter (for example, "H") followed by the applicable section number (for example, "BC H103.1").

(5) The NYC Zoning Resolution (ZR) and the Rules of the City of New York (RCNY). References to the Zoning Resolution and to the Rules of the City of New York are

designated by the abbreviations "ZR" and "RCNY" (for example, "ZR25-41"; "1 RCNY9-01"). The citations "1 RCNY-Misc." and "ZR-Misc." refer to provisions of 1 RCNY or the Zoning Resolution that are not specifically designated elsewhere in the table.

(6) **Reference Standards** that pertain to Title 27 of the NYC Administrative Code (RS). References to the Reference Standards are designated by the abbreviation set out above (for example, "RS-16"). The citation "RS-Misc." refers to Reference Standards that are not specifically designated elsewhere in the table.

(7) **Citations to the New York City Construction Codes.** Whenever a section or subdivision of the New York City Construction Codes is cited or referred to, subordinate consecutively numbered subdivisions or paragraphs of the cited provision are deemed to be included in such reference unless the context or subject matter requires otherwise.

(j) **Classification of particular violations.** Particular violations shall be classified as indicated in the following table:

| Section of Law | Classification | Violation Description |
|-------------------------|----------------|---|
| 1 RCNY-Misc, RS-Misc | Class 1 | Miscellaneous violations. |
| 1 RCNY-Misc, RS-Misc | Class 2 | Miscellaneous violations. |
| 1 RCNY-Misc, RS-Misc | Class 3 | Miscellaneous violations. |
| 1 RCNY 27-03 | Class 1 | Prohibited sign on sidewalk shed or construction fence. |
| 1 RCNY 9-01 | Class 1 | Licensed Rigger designated an unqualified foreman. |
| 1 RCNY 9-01 | Class 2 | Licensed Rigger designated an unqualified foreman. |
| 1 RCNY 9-03 | Class 1 | Licensed Rigger failed to ensure scaffold worker met minimum req. |
| 1 RCNY 9-03 | Class 2 | Licensed Rigger failed to ensure scaffold worker met minimum req. |
| 27-185 & BC 3007.1 | Class 2 | Operation of an elevator without equipment use permit or service equipment Certificate of Compliance. |

Rules and Regulations

| | | |
|----------------------------|---------|--|
| 27-228.5 | Class 2 | Failure to file an Architect/Engineer report certifying exit/directional signs are connected to emergency power source/ storage battery equipment. |
| 27-369 & BC 1020.2 | Class 1 | Failure to provide un-obstructed exit passageway. |
| 27-371 & BC 715.3.7 | Class 2 | Exit door not self-closing. |
| 27-382 & BC 1006.3 | Class 2 | Failure to provide power for emergency exit lighting. |
| 27-383(b) & BC 403.16 | Class 1 | Failure to install photo-luminescent exit path marking in a high-rise building. |
| 27-391 & BC 3002.3 | Class 2 | Emergency signs at elevator call stations missing, defective or non-compliant with section requirements. |
| 27-393 & BC 1019.1.7 | Class 2 | Stair identification signs missing and/or defective. |
| 27-509 & BC 3111.1 | Class 3 | Fence exceeds permitted height. |
| 27-528 & BC 1024.1.3 | Class 2 | Approved Place of Assembly plans not available for inspection. |
| 27-901(z)(1) & PC 301.6 | Class 2 | Piping installed in elevator/ counterweight hoistway. |
| 27-904 & FGC 406.6.2 | Class 1 | Gas being supplied to building without inspection and certification by DOB. |
| 27-904 & FGC 406.6.2 | Class 2 | Gas being supplied to building without inspection and certification by DOB. |
| 27-921(a) & PC 107.3 | Class 1 | Failure to have new or altered plumbing system tested. |
| 27-921(a) & PC 107.3 | Class 2 | Failure to have new or altered plumbing system tested. |
| 27-972(h) & BC 907.2.12.3 | Class 2 | Failure to install an acceptable two-way voice communication system with central station connection. |
| 27-Misc, 28-Misc, BC -Misc | Class 1 | Miscellaneous violations. |
| 27-Misc, 28-Misc, BC -Misc | Class 2 | Miscellaneous violations. |

| | | |
|----------------------------|---------|--|
| 27-Misc, 28-Misc, BC -Misc | Class 3 | Miscellaneous violations. |
| 28-104.2.2 | Class 2 | Failure to provide approved/ accepted plans at job site at time of inspection. |
| 28-105.1 | Class 2 | Failed to obtain a temporary construction permit prior to installation/use of sidewalk shed. |
| 28-105.1 | Class 1 | Work without a permit. |
| 28-105.1 | Class 2 | Work without a permit. |
| 28-105.1 | Class 3 | Work without a permit. |
| 28-105.1 | Class 2 | Work without a permit: Expired permit. |
| 28-105.1 | Class 1 | Construction or alteration work w/o a permit in manufacturing district for residential use. |
| 28-105.1 | Class 2 | Construction or alteration work w/o a permit in manufacturing district for residential use. |
| 28-105.1 | Class 1 | Demolition work without required demolition permit |
| 28-105.1 | Class 1 | Plumbing work without a permit in manufacturing district for residential use. |
| 28-105.1 | Class 2 | Plumbing work without a permit in manufacturing district for residential use. |
| 28-105.1 | Class 2 | Outdoor sign on display structure without a permit. |
| 28-105.1 | Class 1 | Outdoor Ad Co sign on display structure without a permit. |
| 28-105.12.2 | Class 2 | Work does not conform to approved construction documents and/or approved amendments. |
| 28-105.12.2 | Class 3 | Work does not conform to approved construction documents and/or approved amendments. |
| 28-105.12.2 | Class 1 | Work does not conform to approved construction documents and/or approved amendments in a manufacturing district for residential use. |

Rules and Regulations

| | | |
|-------------|---------|---|
| 28-105.12.2 | Class 2 | Work does not conform to approved construction documents and/or approved amendments in a manufacturing district for residential use. |
| 28-105.12.2 | Class 1 | Place of Assembly contrary to approved construction documents. |
| 28-105.12.2 | Class 2 | Place of Assembly contrary to approved construction documents. |
| 28-105.12.2 | Class 1 | Outdoor Ad Co sign is contrary compliance with construction documents. |
| 28-117.1 | Class 1 | Operation of a Place of Assembly without a current Certificate of Operation. |
| 28-117.1 | Class 2 | Operation of a Place of Assembly without a current Certificate of Operation. |
| 28-118.2 | Class 1 | New building or open lot occupied without a valid certificate of occupancy. |
| 28-118.3 | Class 1 | Altered/changed building occupied without a valid Certificate of Occupancy as per §28-118.3.1 - §28-118.3.2. |
| 28-118.3 | Class 2 | Altered/changed building occupied without a valid Certificate of Occupancy as per §28-118.3.1 - §28-118.3.2. |
| 28-118.3 | Class 1 | Change in occupancy/use of C of O as per §28-118.3.1 - §28-118.3.2 by operating a Place of Assembly as per when current C of O does not allow such occupancy. |
| 28-118.3 | Class 2 | Change in occupancy/use of C of O as per §28-118.3.1 - §28-118.3.2 by operating a Place of Assembly as per when current C of O does not allow such occupancy. |
| 28-118.3.2 | Class 1 | Occupancy contrary to that allowed by the Certificate of Occupancy or Building Department records. |
| 28-118.3.2 | Class 2 | Occupancy contrary to that allowed by the Certificate of Occupancy or Building Department records. |

| | | |
|------------|---------|---|
| 28-118.3.2 | Class 3 | Occupancy contrary to that allowed by the Certificate of Occupancy or Building Department records. |
| 28-202.1 | Class 1 | Additional daily penalty for Class 1 violation of 28-210.1 - 1 or 2 family converted to greater than 4 family. |
| 28-202.1 | Class 2 | Additional monthly penalty for continued violation of 28-210.1 |
| 28-202.1 | Class 1 | Additional daily civil penalties for continued violations. |
| 28-202.1 | Class 2 | Additional monthly civil penalties for continued violations. |
| 28-202.1 | Class 2 | Additional monthly penalty for continued violation of 28-210.2 |
| 28-204.4 | Class 2 | Failure to comply with the commissioner's order to file a certificate of correction with the Department of Buildings. |
| 28-207.2.2 | Class 1 | Unlawfully continued work while on notice of a stop work order. |
| 28-210.1 | Class 1 | Residence altered for occupancy as a dwelling from 1 or 2 families to greater than 4 families. |
| 28-210.1 | Class 2 | Residence altered for occupancy as a dwelling for more than the legally approved number of families |
| 28-210.2 | Class 2 | Maintain or permit conversion of industrial/manufacturing bldg to residential use w/out C of O/code compliance |
| 28-210.2 | Class 2 | Plumbing work contrary to approved app'n/plans that assists/maintains convers'n of indust/manuf occupancy for resid use |
| 28-211.1 | Class 1 | Filed a certificate, form, application etc., containing a material false statement(s). |
| 28-301.1 | Class 1 | Failure to maintain building in code-compliant manner. |

Rules and Regulations

| | | |
|----------|---------|--|
| 28-301.1 | Class 2 | Failure to maintain building in code-compliant manner. |
| 28-301.1 | Class 3 | Failure to maintain building in code-compliant manner. |
| 28-301.1 | Class 1 | Failure to maintain building in code-compliant manner: Use of prohibited door and/or hardware per BC 1008.1.8; 27-371(j). |
| 28-301.1 | Class 2 | Failure to maintain building in code-compliant manner: Use of prohibited door and/or hardware per BC 1008.1.8; 27-371(j). |
| 28-301.1 | Class 1 | Failure to maintain building in code-compliant manner: illumination for exits, exit discharges and public corridors per BC 1006.1;27-381. |
| 28-301.1 | Class 2 | Failure to maintain building in code-compliant manner: illumination for exits, exit discharges and public corridors per BC 1006.1;27-381. |
| 28-301.1 | Class 1 | Failure to maintain building in code-compliant manner: floor numbering signs missing and/or defective per BC 1019.1.7;27-392 |
| 28-301.1 | Class 2 | Failure to maintain building in code-compliant manner: floor numbering signs missing and/or defective per BC 1019.1.7;27-392 |
| 28-301.1 | Class 1 | Failure to maintain building in code-compliant manner: high-rise to provide exit sign requirement(s) within exits per BC 1011.1.1; 27-383.1. |
| 28-301.1 | Class 2 | Failure to maintain building in code-compliant manner: high-rise to provide exit sign requirement(s) within exits per BC 1011.1.1;27-383.1. |
| 28-301.1 | Class 1 | Failure to maintain building in code-compliant manner: lack of emergency power or storage battery connection to exit signs per BC 1011.5.3; 27-384 (c). |
| 28-301.1 | Class 1 | Failure to maintain building in code-compliant manner: lack of emergency lighting for exits, exit discharges and public corridors per BC 1006.1; 27-542. |

| | | |
|----------|---------|--|
| 28-301.1 | Class 2 | Failure to maintain building in code-compliant manner: lack of emergency lighting for exits, exit discharges and public corridors per BC 1006.1; 27-542. |
| 28-301.1 | Class 2 | Failure to maintain building in code-compliant manner: failure to provide non-combustible proscenium curtain per BC410.3.5; 27-546. |
| 28-301.1 | Class 1 | Failure to maintain building in code-compliant manner: no fire stopping per BC 712.3; 27-345. |
| 28-301.1 | Class 2 | Failure to maintain building in code-compliant manner: no fire stopping per BC 712.3; 27-345. |
| 28-301.1 | Class 1 | Failure to maintain building in code-compliant manner: Improper exit/exit access doorway arrangement per BC 1014.2; 27-361. |
| 28-301.1 | Class 1 | Failure to maintain building in code-compliant manner: service equipment – elevator per BC 3001.2; 27-987. |
| 28-301.1 | Class 2 | Failure to maintain building in code-compliant manner: service equipment – elevator per BC 3001.2; 27-987. |
| 28-301.1 | Class 3 | Failure to maintain building in code-compliant manner: service equipment – elevator per BC 3001.2; 27-987. |
| 28-301.1 | Class 1 | Failure to maintain building in code-compliant manner: service equipment – boiler. |
| 28-301.1 | Class 2 | Failure to maintain building in code-compliant manner: service equipment – boiler. |
| 28-301.1 | Class 3 | Failure to maintain building in code-compliant manner: service equipment – boiler. |
| 28-301.1 | Class 1 | Failure to maintain building in code-compliant manner: lack of a system of automatic sprinklers where required per BC 903.2; 27-954. |

Rules and Regulations

| | | |
|----------|---------|---|
| 28-301.1 | Class 2 | Failure to maintain building in code-compliant manner: lack of a system of automatic sprinklers where required per BC 903.2; 27-954. |
| 28-301.1 | Class 2 | Failure to maintain building in code-compliant manner re: installation/maintenance of plumbing materials/equipment per PC102.3;27-902. |
| 28-301.1 | Class 2 | Failure to maintain building in code-compliant manner: Gas vent reduced or undersized as per FGC 504.2; 27-887. |
| 28-301.1 | Class 2 | Failure to maintain building in code-compliant manner: failure to comply with law for water supply system per PC 602.3; 27-908(c). |
| 28-301.1 | Class 2 | Failure to maintain building in code-compliant manner: failure to comply with law for drainage system per PC 702.1; 27-911. |
| 28-301.1 | Class 2 | Failure to maintain building in code-compliant manner: Plumbing fixture(s) not trapped and/or vented per PC 916.1 & PC 1002.1; 27-901(o). |
| 28-301.1 | Class 1 | Failure to maintain building in code-compliant manner: Misc sign violation by Outdoor Ad Co as per 27-498 through 27-508 & BC H103.1. |
| 28-301.1 | Class 2 | Failure to maintain sign in accordance w Tit.27;Tit.28; ZR;RCNY |
| 28-302.1 | Class 1 | Failure to maintain building wall(s) or appurtenances. |
| 28-302.1 | Class 2 | Failure to maintain building wall(s) or appurtenances. |
| 28-302.1 | Class 3 | Failure to maintain building wall(s) or appurtenances. |
| 28-302.4 | Class 2 | Failure to submit a required report of critical examination documenting condition of exterior wall and appurtenances. |

| | | |
|------------------------|---------|--|
| 28-302.5 | Class 2 | Failure to file an amended report acceptable to this Department indicating correction of unsafe conditions. |
| 28-303.7 | Class 2 | Failure to file complete boiler inspection report. |
| 28-401.16 | Class 2 | Held self out as licensed, certified, registered etc., to perform work requiring a DOB license w/o obtaining such license. |
| 28-401.9 | Class 1 | Failure to file evidence of liability &/or property damage insurance. |
| 28-401.9 | Class 1 | Failure to file evidence of compliance with Workers Comp, law and/or disability benefits law. |
| 28-404.1 | Class 1 | Supervision or use of rigging equipment without a Rigger's license. |
| 28-404.4.1 | Class 2 | Licensed Master/Special Rigger failed to place appropriate "Danger" sign while using rigging equipment. |
| 28-405.1 | Class 1 | Supervision or use of power-operated hoisting machine without a Hoisting Machine Operator's license. |
| 28-405.1 | Class 2 | Supervision or use of power-operated hoisting machine without a Hoisting Machine Operator's license. |
| 28-408.1 | Class 2 | Performing unlicensed plumbing work without a master plumber license. |
| 28-502.6 | Class 1 | Misc sign viol'n by outdoor ad co of Tit.27;Tit.28;ZR;or BC |
| BC 1016.2 | Class 2 | Failure to maintain building in code-compliant manner: provide required corridor width per BC 1016.2; 27-369 |
| BC 3010.1 & 27-1006 | Class 1 | Failure to promptly report an elevator accident involving personal injury requiring the services of a physician or damage to property. |
| BC 3301.2 & 27-1009(a) | Class 1 | Failure to safeguard all persons and property affected by construction operations. |

Rules and Regulations

| | | | | | |
|-----------------------------|---------|--|---------------------------------|---------|--|
| BC 3301.2 & 27-1009(a) | Class 2 | Failure to safeguard all persons and property affected by construction operations. | BC 3310.5 & 27-1009(d) | Class 1 | Failure to have Site Safety Manager or Coordinator present as required. |
| BC 3301.2 & 27-1009(a) | Class 1 | Failure to institute/maintain safety equipment measures or temporary construction – No guard rails | BC 3314.2 & 27-1042 | Class 1 | Erected or installed supported scaffold 40 feet or higher without a permit. |
| BC 3301.2 & 27-1009(a) | Class 1 | Failure to institute/maintain safety equipment measures or temporary construction – No toe boards. | BC 3314.1.1 & 27-1050.1 | Class 2 | Failed to notify Department prior to use/inst. *off C-hooks/outrigger beams in connection with Suspended Scaffold |
| BC 3301.2 & 27-1009(a) | Class 1 | Failure to institute/maintain safety equipment measures or temporary construction – No handrails. | BC 3314.4.3.1 & 27-1045 | Class 1 | Failure to perform safe/proper inspection of suspended scaffold. |
| BC 3301.9 & 27-1009 (c) | Class 2 | Failure to provide/post sign(s) at job site pursuant to subsection. | BC 3314.4.3.1 & 27-1045(b) | Class 1 | No record of daily inspection of Suspended Scaffold performed by authorized person at site. |
| BC 3303.3 & 27-1020 | Class 2 | Failure to post D.O.T. permit for street/sidewalk closing. | BC 3314.4.5 & 26-204.1 (a) | Class 1 | Erected, dismantled repaired, maintained, modified or removed supported scaffold without a scaffold certificate of completion. |
| BC 3303.4 & 27-1018 | Class 2 | Failure to maintain adequate housekeeping per section requirements. | BC 3314.4.5 & 26-204.1 (a) | Class 2 | Erected, dismantled repaired, maintained, modified or removed supported scaffold without a scaffold certificate of completion. |
| BC 3304.3 & 1 RCNY 52-01(a) | Class 1 | Failure to notify the Department prior to the commencement of earthwork. | BC 3314.4.6 & 26-204.1 (c) | Class 1 | Use of supported scaffold without a scaffold user certificate. |
| BC 3304.3 & 1 RCNY 52-01(b) | Class 2 | Failure to notify the Department prior to the cancellation of earthwork. | BC 3314.4.6 & 26-204.1 (c) | Class 2 | Use of supported scaffold without a scaffold user certificate. |
| BC 3304.4 & 27-1032 | Class 1 | Failure to provide protection at sides of excavation. | BC 3314.6.3 & 27-1009 | Class 1 | Failure to provide/use lifeline while working on scaffold. |
| BC 3306 & 27-1039 | Class 1 | Failure to carry out demolition operations as required by section. | BC 3314.6.3 & 27-1009 | Class 2 | Failure to provide/use lifeline while working on scaffold. |
| BC 3306.2.1 | Class 1 | Failure to provide safety zone for demolition operations. | BC 3316.2 & BC 3319.1 & 27-1054 | Class 1 | Inadequate safety measures: Oper'n of crane/ derrick/ hoisting equip in unsafe manner).** |
| BC 3306.3 & 27-195 | Class 1 | Failure to provide required notification prior to the commencement of demolition. | BC 3319.3 | Class 1 | Operation of a crane/derrick without a Certificate of Operation. |
| BC 3306.5 | Class 1 | Mechanical demolition without plans on site. | BC 3319.3 & 27-1057(b) | Class 2 | Operation of crane/derrick without Certificate of Approval/Certificate of Operation. |
| BC 3307.3.1 & 27-1021(a) | Class 1 | Failure to provide sidewalk shed where required. | BC 3319.3 & 27-1057(d) | Class 2 | Operation of a crane/derrick without a Certificate of Onsite Inspection. |
| BC 3307.6 & 27-1021 | Class 2 | Sidewalk shed does not meet code specifications. | | | |
| BC 3307.7 & 27-1021(c) | Class 2 | Job site fence not constructed pursuant to subsection. | | | |
| BC 3309.4 & 27-1031 | Class 1 | Failure to protect adjoining structures during excavation operations. | | | |

Rules and Regulations

| | | |
|----------------------------|---------|--|
| PC-Misc, FGC-Misc, MC-Misc | Class 1 | Miscellaneous violations. |
| PC-Misc, FGC-Misc, MC-Misc | Class 2 | Miscellaneous violations. |
| PC-Misc, FGC-Misc, MC-Misc | Class 3 | Miscellaneous violations. |
| RS 6-1 | Class 1 | Failure to file affidavits and/or comply with other requirements set forth for photoluminescent exit path marking. |
| ZR 42-543 | Class 1 | Outdoor Ad Co sign in M Dist exceeds height limit. |
| ZR 22-00 | Class 2 | Illegal use in residential district. |
| ZR 22-32 | Class 1 | Outdoor Ad Co has impermissible advertising sign in an R Dist. |
| ZR 22-342 | Class 1 | Outdoor Ad Co sign in R Dist exceeds height limits. |
| ZR 25-41 | Class 2 | Violation of parking regulations in a residential district. |
| ZR 25-41 | Class 3 | Violation of parking regulations in a residential district. |
| ZR 32-00 | Class 2 | Illegal use in a commercial district. |
| ZR 32-63 | Class 1 | Outdoor Ad Co advertising sign not permitted in specified C Dist. |
| ZR 32-64 | Class 2 | Sign(s) in specified C Dist exceed(s) surface area restrictions. |
| ZR 32-64 | Class 1 | Outdoor Ad Co sign(s) in specified C Dist exceed surface area limits. |
| ZR 32-652 | Class 2 | Sign in specified C Dist extends beyond street line limitation. |
| ZR 32-653 | Class 2 | Prohibited sign on awning, canopy, or marquee in C Dist. |
| ZR 32-655 | Class 1 | Outdoor Ad Co sign exceeds permitted height for specified C Dist. |
| ZR 42-00 | Class 2 | Illegal use in a manufacturing district. |
| ZR 42-52 | Class 1 | Outdoor Ad Sign not permitted in M Dist. |

| | | |
|----------|---------|---|
| ZR 42-53 | Class 1 | Outdoor Ad sign in M Dist exceeds surface area limits. |
| ZR-Misc | Class 2 | Miscellaneous violations of the Zoning Resolution. |
| ZR-Misc | Class 3 | Miscellaneous violations of the Zoning Resolution. |
| ZR-Misc. | Class 1 | Misc sign violation under the Zoning Resolution by an Outdoor Ad Co |
| ZR-Misc. | Class 2 | Misc sign violation under the Zoning Resolution |

**As enacted but "of" probably intended.*

***As enacted but "(") probably not intended.*

§102-02 Compensation of registered design professionals in accordance with section 28-216.6 of the administrative code.

In accordance with the provisions of Administrative Code section 28-216.6, registered design professionals appointed by a recognized professional organization to act on any survey or appointed to resolve disagreement between surveyors shall each be paid the sum of one hundred dollars.

***Subchapter D**

***§104-08 Qualifications for site safety manager and site safety coordinator certificates.**

**Note: There is a numerical gap in numbering.*

(a) *Site safety managers.* The Department of Buildings shall issue a site safety manager certificate to an individual who shall have satisfied the requirements of section 28-402.2 of the Administrative Code.

(1) For purposes of satisfying the requirements of section 28-402.2 of the Administrative Code, equivalent education and construction experience shall consist of successful completion within two years of application for certification of an OSHA 30-hour safety course and one of the following:

(i) Eight years of experience within 10 years prior to the date of the application as a building code enforcement official charged with enforcement of the provisions of the New York City Building Code. The enforcement must have included inspections of major buildings under construction and thus this basis for qualification excludes officials whose primary role is to perform inspections of occupied or vacant buildings; or

(ii) Eight years of field experience working on buildings within 10 years prior to the date of the application as a safety official for a governmental entity or construction firm or as a safety manager or safety engineer for a safety consulting firm specializing in construction. The experience must have included 4 years relevant work on major buildings under construction; or

(iii) Successful completion of a New York State Apprenticeship Program for Site Safety Manager approved by the Department; or

(iv) Ten years of experience within 12 years prior to the date of the application working in a relevant construction trade with plans in furtherance of building construction, five years of which must have been on major buildings under construction and three of those five years must have been in

Rules and Regulations

an on-site supervisory position.

(A) For purposes of this subdivision, each year of formal training or education in a program with emphasis on construction at a college, technical or trade school may be substituted for one year of construction work up to a maximum of three years.

(v) Experience acquired pursuant to this subdivision must have been full-time experience acquired in the United States.

(2) A holder of a site safety manager certificate may not simultaneously hold either an active site safety coordinator certificate or an active registration as a superintendent of construction.

(3) An acceptable 18 month on-the-job training program shall include the following:

(i) The buildings worked on must have been major buildings;

(ii) The work must have been performed under the direct and continuing supervision of a certified site safety manager. For purposes of this subdivision, direct and continuing supervision shall include daily training at the location specified in the monthly summaries in the presence of the supervising certified site safety manager;

(iii) The training program must have been full-time and paid;

(iv) Dated and notarized summaries must have been completed by the certified supervising site safety manager at the end of every month specifying the location and nature of the construction activity at the location for the month covered;

(v) The program must cover all phases of construction and must specify precisely the activity in which the trainee was engaged for the month covered by each monthly summary, including but not limited to excavation, foundation work, plumbing, electrical, and mechanical;

(vi) The supervising certified site safety manager may supervise a maximum of two trainees simultaneously;

(vii) Completion within two years of application for certification of an OSHA 30-hour safety course.

(b) *Site Safety Coordinators.* The Department of Buildings shall issue a site safety coordinator certificate to an individual who shall have satisfied the requirements of section 28-403.2 of the Administrative Code.

(1) For purposes of satisfying the requirements of section 28-403.2 of the Administrative Code, equivalent education and construction experience shall consist of successful completion within two years of application for certification of an OSHA 30-hour safety course and one of the following:

(i) Five years of experience within 10 years prior to the date of the application as a building code enforcement official charged with enforcement of the provisions of the New York City Building Code. The enforcement must have included inspections of major buildings under construction and thus this basis for qualification excludes officials whose primary role is to perform inspections of occupied or vacant buildings; or

(ii) Five years of field experience working on buildings within 10 years prior to the date of the application as a safety official for a governmental entity or construction firm or as a

safety manager or safety engineer for a safety consulting firm specializing in construction. The experience must have included 2.5 years relevant work on major buildings under construction; or

(iii) Five years of experience within 10 years prior to the date of the application working in a relevant construction trade with plans in furtherance of building construction, three years of which must have been on major buildings under construction and two of those three years must have been in an on-site supervisory position.

(A) For purposes of this subdivision, each year of formal training or education in a program with emphasis on construction at a college, technical or trade school may be substituted for one year of construction work up to a maximum of two years.

(iv) Experience acquired pursuant to this rule must have been full-time experience acquired in the United States.

(2) A holder of a site safety coordinator certificate may not simultaneously hold either an active site safety manager certificate or an active registration as a superintendent of construction.

(3) Applicants for a site safety coordinator certificate shall not be required to take an examination in order to qualify for the certificate.

(c) The term "major building" as used in this rule shall have the meaning given to it in Chapter 33 of the New York City Building Code.

APPENDIX A

DEPARTMENT OF BUILDINGS

Promulgation of Amendments to Regulations Relating to Public Access to Records

Pursuant to Section 1105 of the New York City Charter and by virtue of the authority vested in me as Commissioner of Buildings by Section 643 of such Charter, herewith promulgated are the following amendments to regulations of the Commissioner of Buildings relating to Regulations Relating to Public Access to Records.

REGULATIONS RELATING TO PUBLIC ACCESS TO RECORDS

RULE 1. PURPOSE- The Department of Buildings, in full accordance with the letter and spirit of the State Freedom of Information Law, effective September 1, 1974, does hereby enact regulations to permit all members of the public access to its records.

RULE 2. DEFINITIONS-(a) the term "records" shall mean all information on file which the Department of Buildings is authorized to disclose to the public pursuant to Article 6 of the Public Officers Law and Section 1113 and 1114 of the New York City Charter. Records shall be classified in two categories as follows:

(1) *Records routinely made available for public inspection.* Such records include, but are not limited to: building applications, plans, certificates of occupancy, index cards and index printouts, violations and complaints with the complainant's name and address deleted.

(2) Records not routinely made available for public inspection.

Rules and Regulations

(b) The term "offices" shall mean the offices of the Department of Buildings which are located at the addresses provided in the City's website, <http://www.nyc.gov>.

RULE 3. AVAILABILITY-(a) Routine records may be requested at the office where such records are maintained. Requests for said records should be made to the Records Control Officer in the respective office or his/her designee.

(b) Requests for copies or the viewing of records which are not routinely available for public inspection must be made in writing to the Records Access Officer, General Counsel's Office, Department of Buildings (address provided in the City's website, <http://www.nyc.gov>).

(c) Records are available for public inspection and copying on weekdays and, except holidays, during regular business hours which may vary from office to office.

RULE 4. DESIGNATION OF RECORDS CONTROL OFFICERS- The respective records control officers of the Department of Buildings for the respective offices are hereby designated as follows:

(a) Executive offices

(1) Materials and Equipment Acceptance Division- Director

(2) Division of Cranes and Derricks-Assistant Commissioner

(3) Central Billing Section - Director of Fiscal Operations

(b) Borough offices

(1) Borough of Manhattan- Borough Manager

(2) Borough of The Bronx- Borough Manager

(3) Borough of Brooklyn- Borough Manager

(4) Borough of Queens- Borough Manager

(5) Borough of Staten Island - Borough Manager

(c) Boiler Division Office - Chief, Boiler Division

(d) Elevator Division Office - Director, Elevator Division

(e) Bureau of Electrical Control- Director

Existing Rules 5, 6, 7 and 8, which were effective September 1, 1974, are deleted and proposed Rules 5 and 6 are added.

RULE 5. FEES- A maximum fee of twenty-five cents is to be charged for each photocopy of departmental records not in excess of nine inches by fourteen inches except for certificates of pending violations (violation searches) and photocopies of individual violations. The fee for certificates of pending violations and for photocopies of individual violations will remain as stated in Section 26-214 of the Building Code. This exception from the twenty-five cents maximum fee limit, which applies to violation searches and copies of violations, does not apply to copies of Bureau of Electrical Control notice of violations and certificates of electrical inspection. The fee charged for any photocopy of departmental records which is larger than nine inches by fourteen inches is to be the actual cost of reproduction.

RULE 6. REVIEW OF DENIAL OF ACCESS- A denial by Records Access Officer may be appealed in writing within thirty days after the receipt of the denial. Appeals should be directed to the F.O.I.L. Appeals Officer (address provided in the City's website, <http://www.nyc.gov>)

This space intentionally left blank.